

As this item contains many parts, please read the installation instruction carefully before installation . Please use tools properly and carefully.

Before You Start

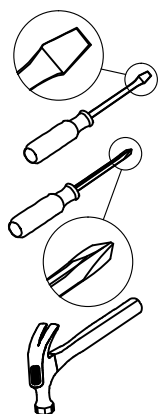

- ✓ Read through each step carefully and follow the proper order
- ✓ Separate and count all your parts and hardware
- ✓ Give yourself enough room for the assembly process
- ✓ Have the following tools: Flat Head Screwdriver, #2 Phillips Head Screwdriver and Hammer
- ✓ Caution: If using a power drill or power screwdriver for screwing, please be aware of to slow down and stop when screw is tight. Failure to do so may result in stripping the screw. (Assembly speed can be increased by using electric screwdriver)

Helpful Hints

PEOPLE NEEDED FOR ASSEMBLY: 1-2

- Open your item in the area you plan to keep it to avoid excessive heavy lifting.
- Identify, sort and count the parts before attempting assembly.
- Compression dowels are lightly tapped in with a hammer.
- Slides are labeled with an **R** (right) and **L** (left) for proper placement.
- Make sure to always face the point on the top of the Cam Lock towards the outer edge.
- If there is a back panel in the package, please install it to make sure your unit is complete and sturdy.
- Please fix all the screws provided for the back panel which can enhance product stability. If it is difficult to fix it when tightening, it can be fixed with the help of a hammer and then tightened.
- Do NOT use harsh chemicals or abrasive cleaners on this item.
- Never push, pull, or drag your furniture.



Board Identification

Not actual size

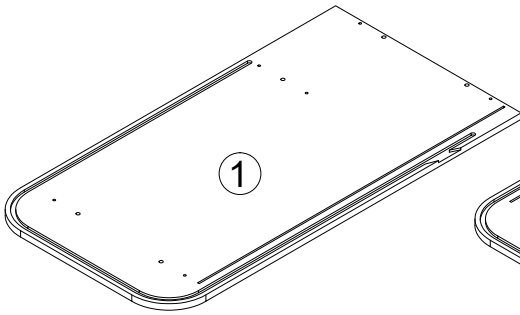

TOP PANEL
Qty:1

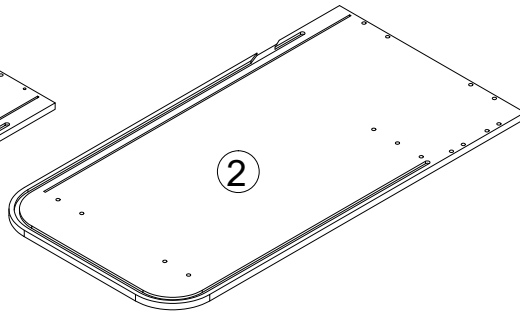

BOTTOM PANEL
Qty:1

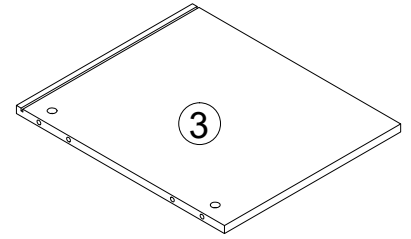

LEFT SIDE PANEL
Qty:1

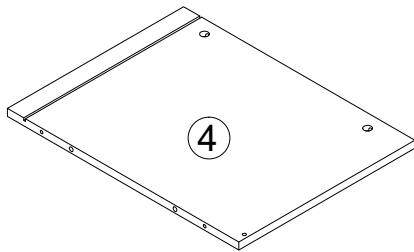

RIGHT SIDE PANEL
Qty:1

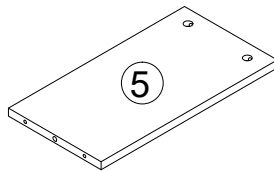

DIVIDER PANEL
Qty:1

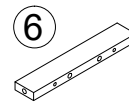

FRONT UPPER BAR
Qty:1

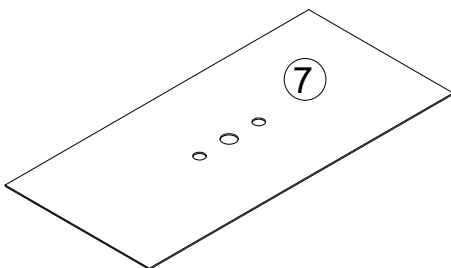

BACK PANEL
Qty:1

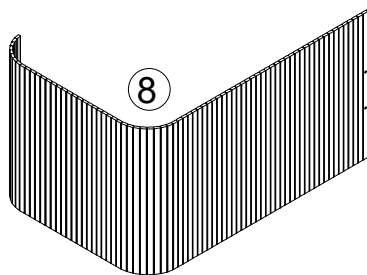

DOOR PANEL
Qty:1

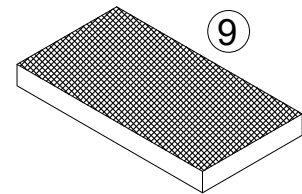

CAT SCRATCHER
CARDBOARD
Qty:1

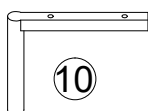

LEG
Qty:2

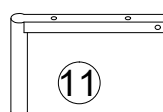

LEG
Qty:2

Part List

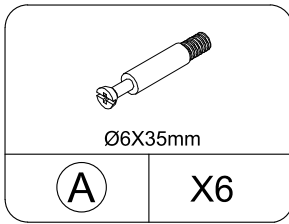

CAM BOLT
spare:1

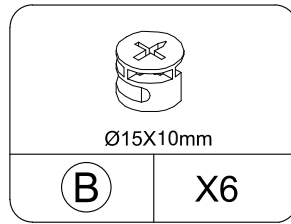

CAM LOCK
spare:1

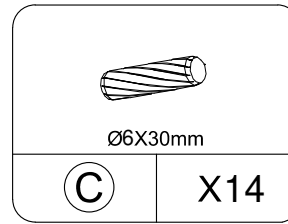

WOOD DOWEL
spare:2

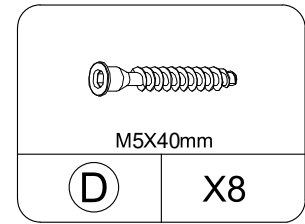

BOLT
spare:1

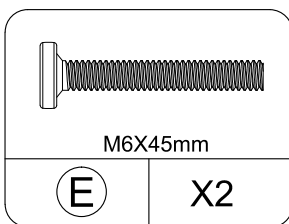

BOLT

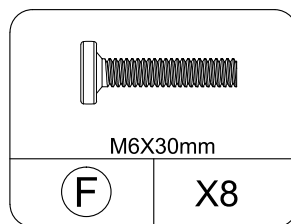

BOLT
spare:1

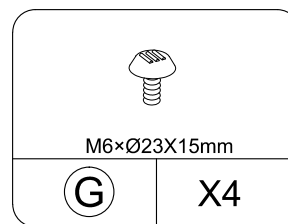

ADJUSTABLE FEET

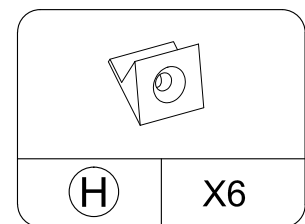

PLASTIC BUCKLE
spare:1

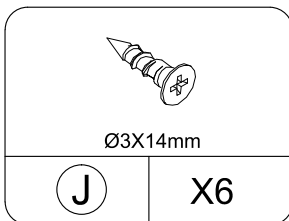

SCREW
spare:1

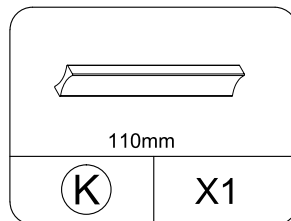

HANDLE

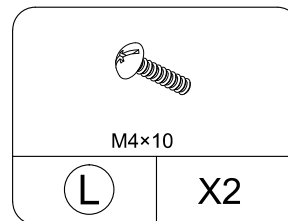

BOLT

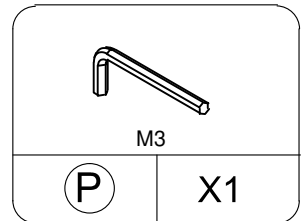

ALLEN KEY

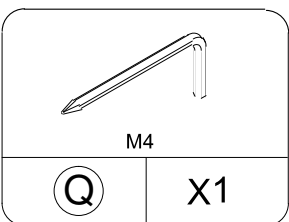

ALLEN KEY

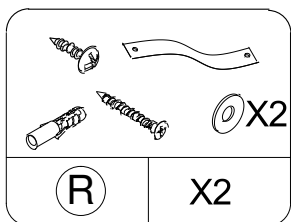

PREVENTIVE DUMPING
ACCESSORIES

Part List

Cam Lock Fastening System

Insert the cam bolt into the hole first, then insert the cam lock and lock it.

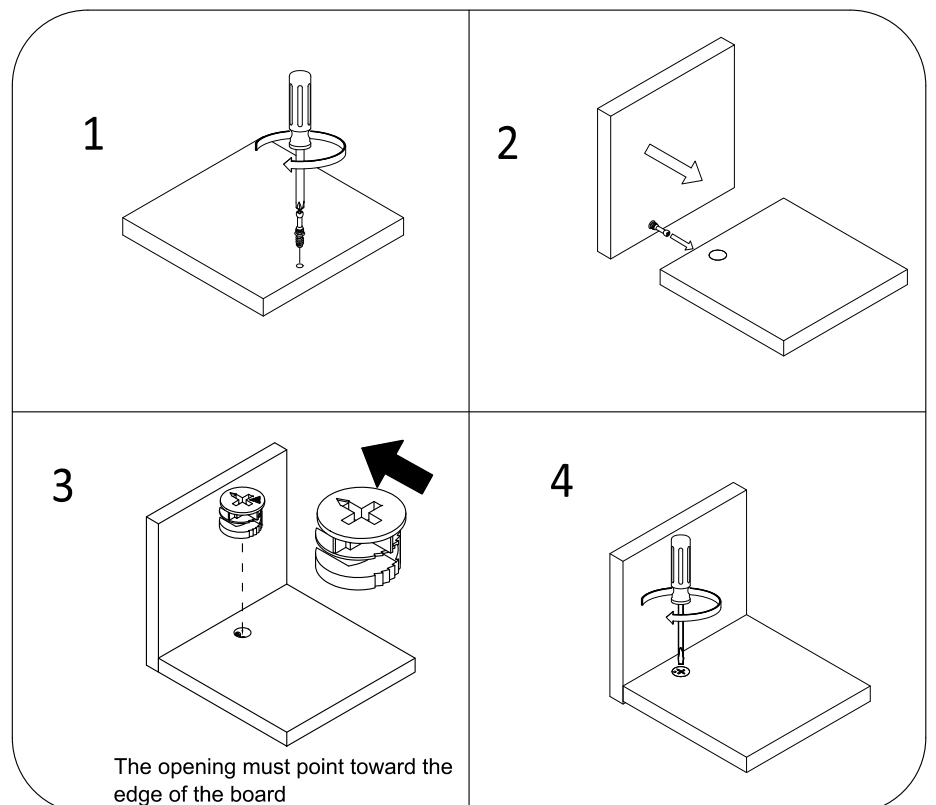

Board Identification

Not actual size

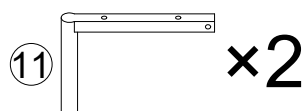
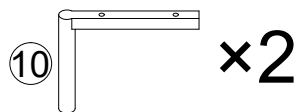
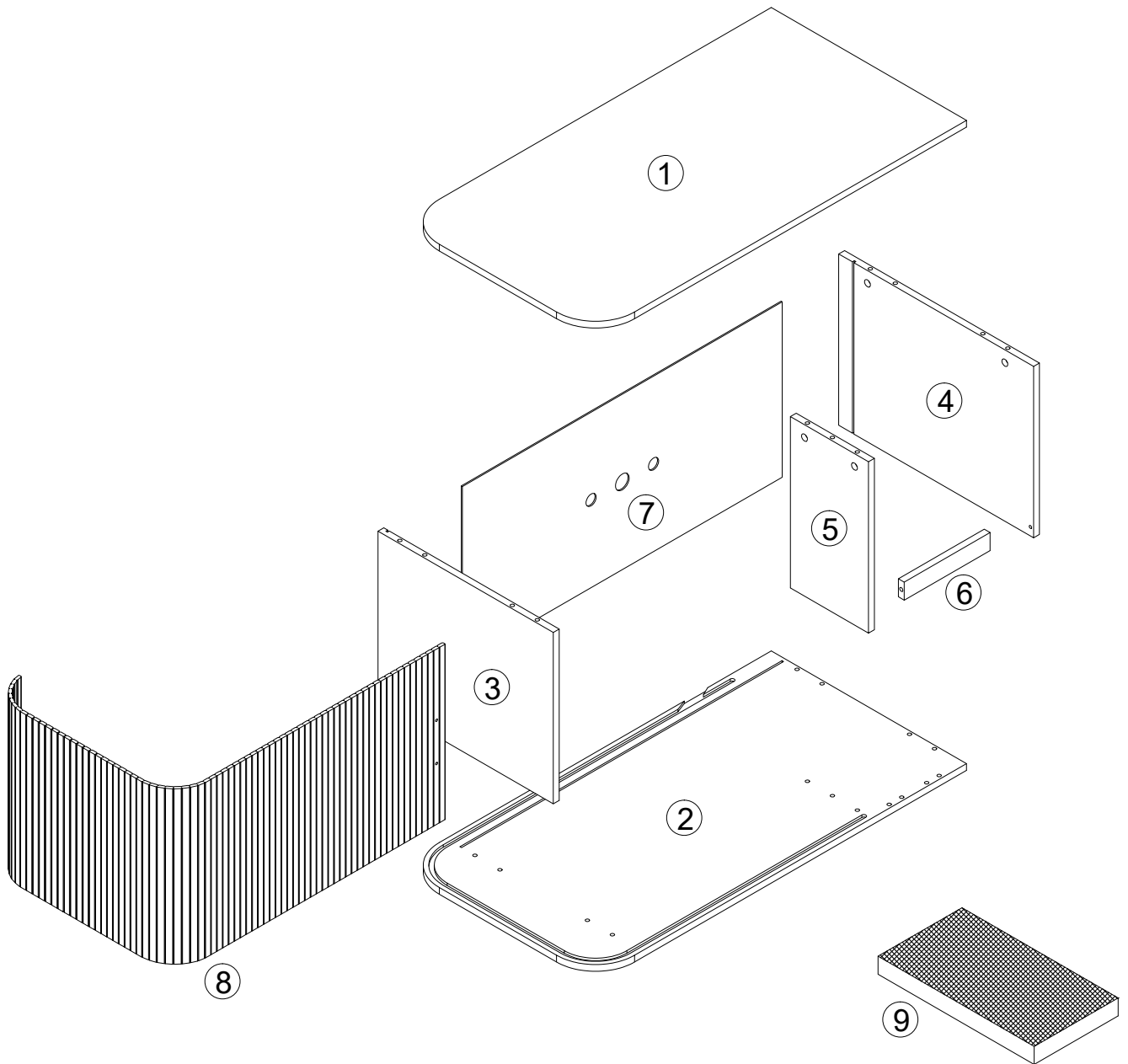

STEP1

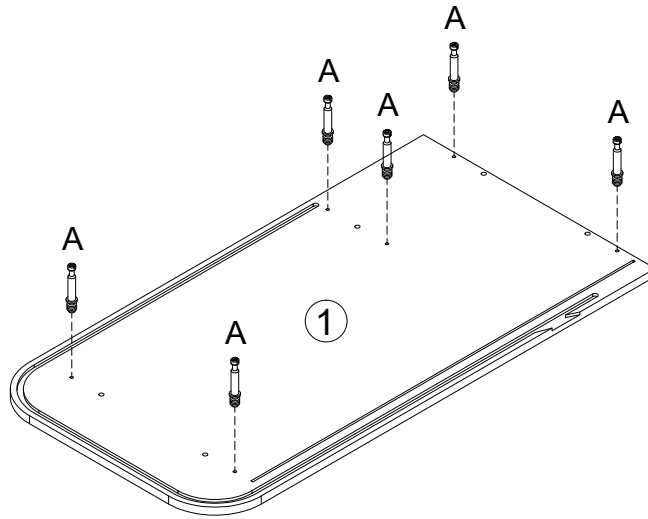
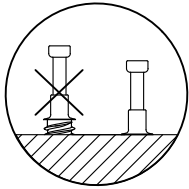
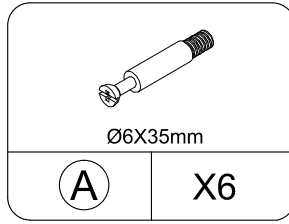
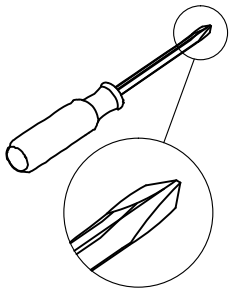

STEP2

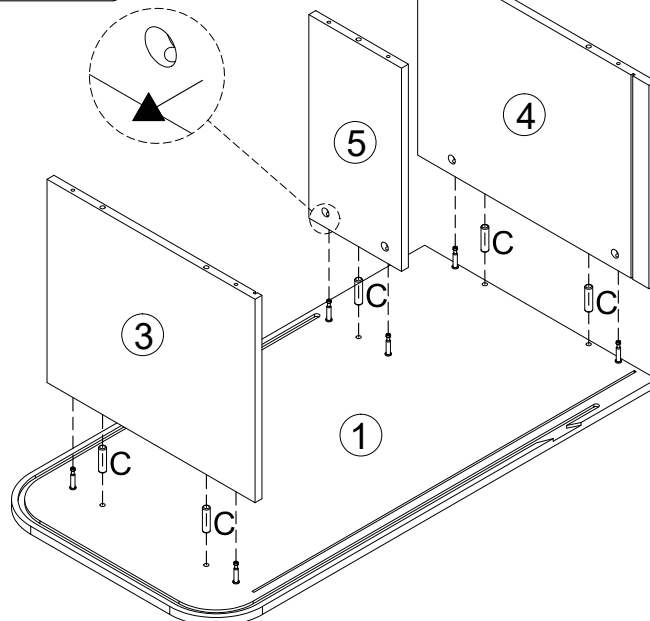
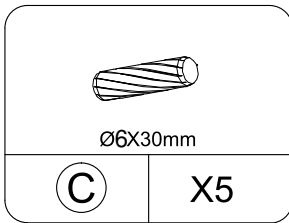

STEP3

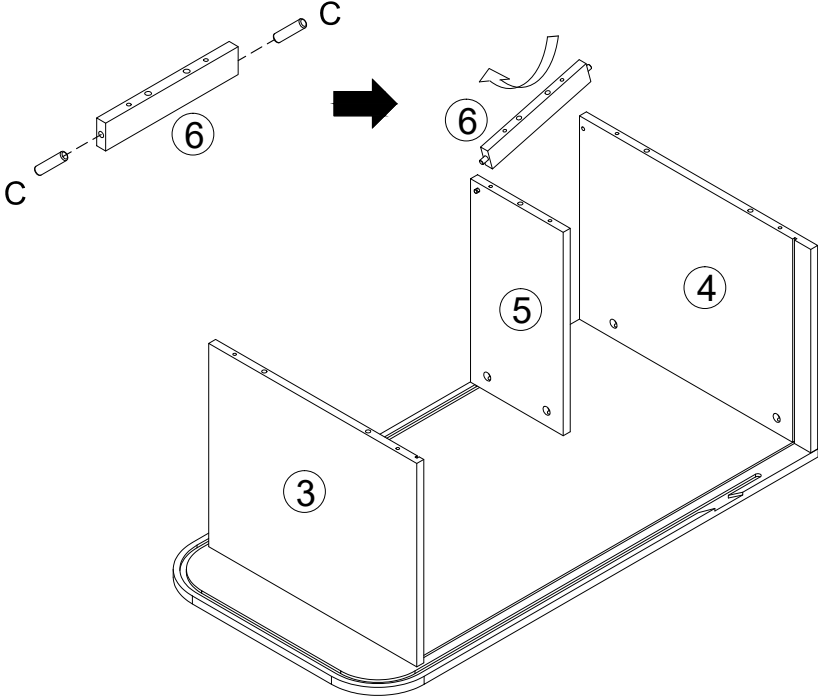
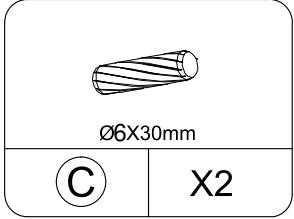

STEP4

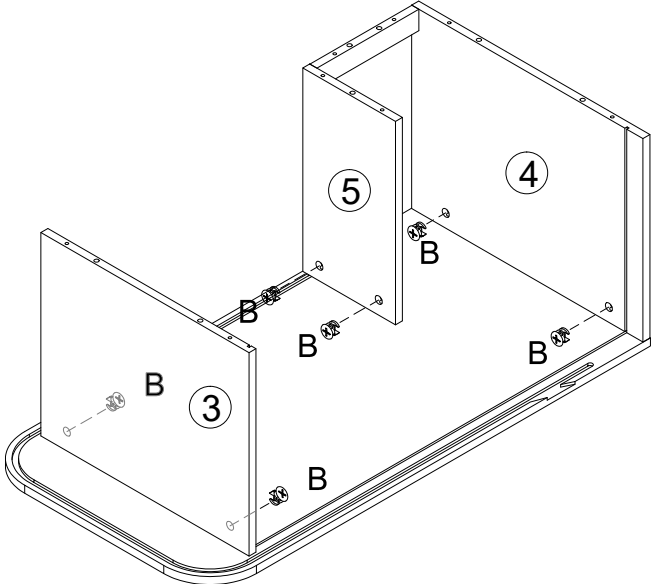
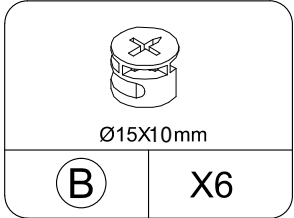
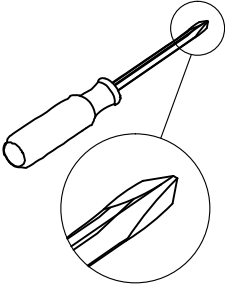

STEP 5

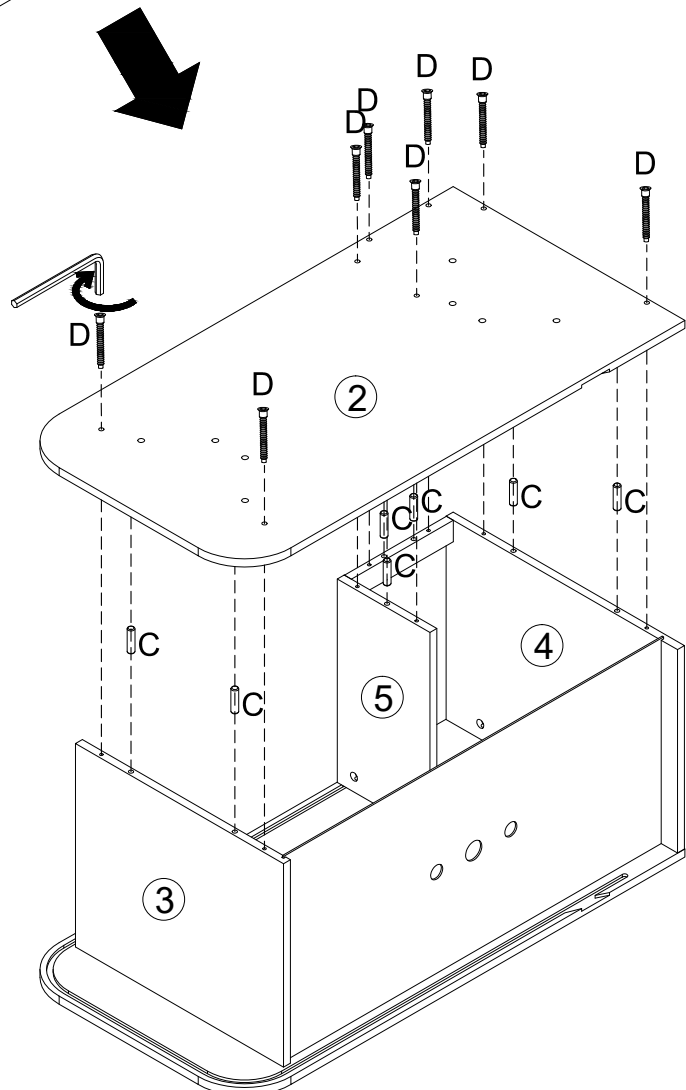
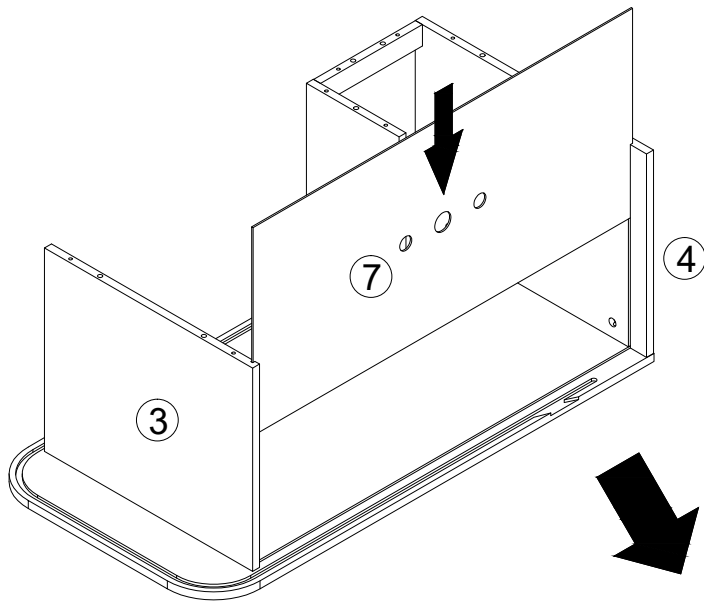
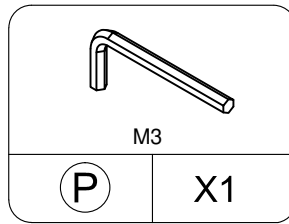
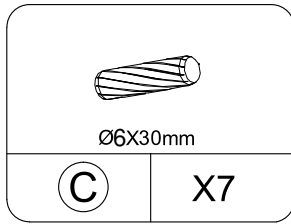
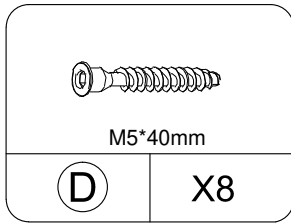

STEP 6

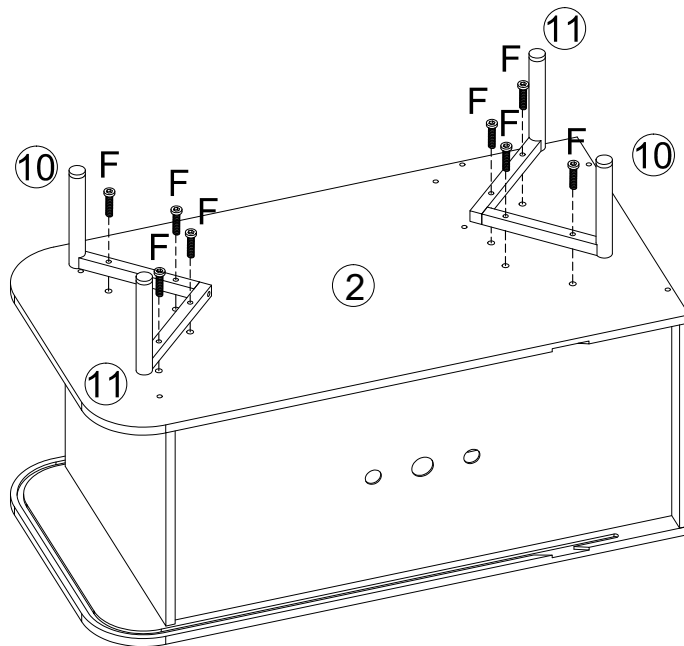
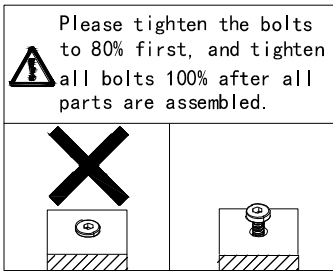
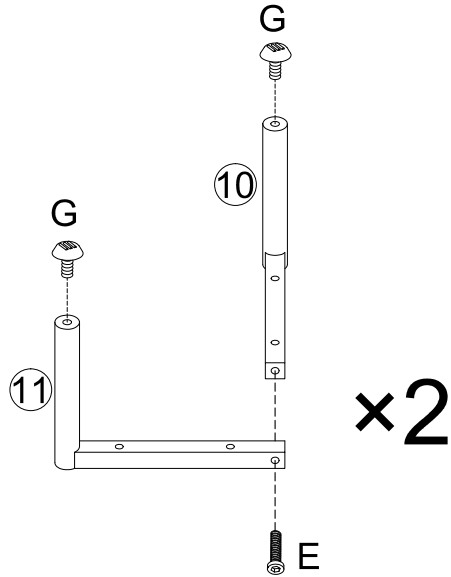
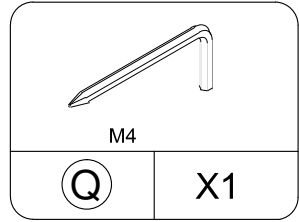
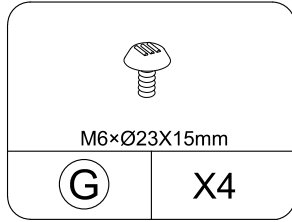
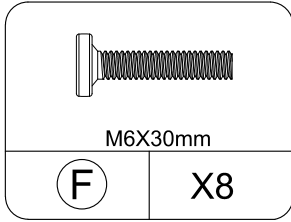
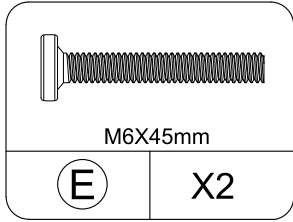

STEP 7

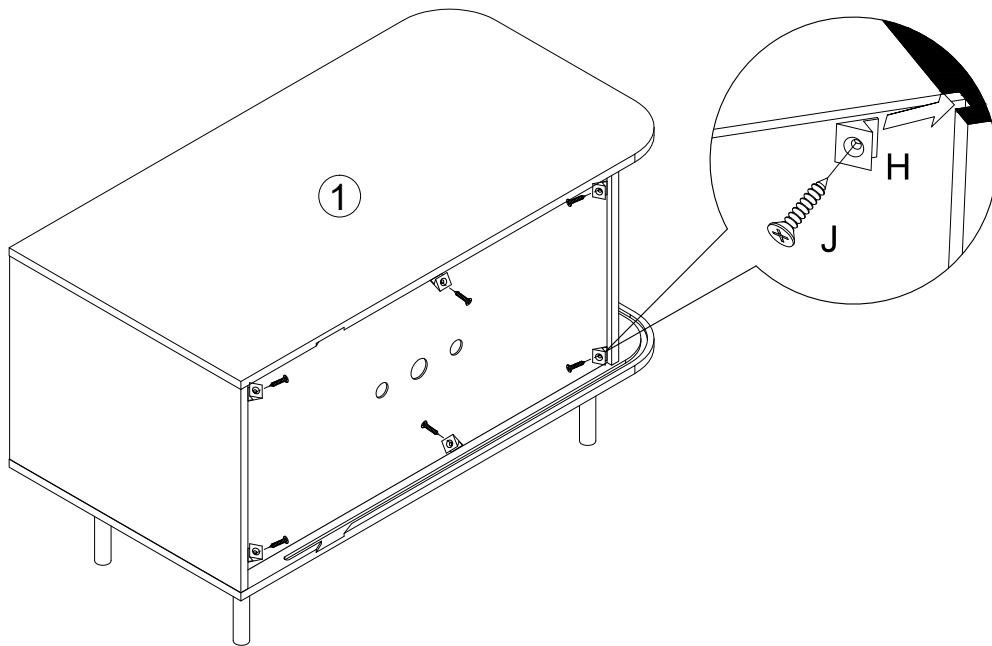
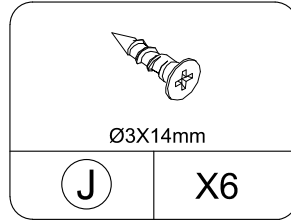
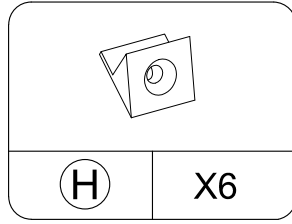
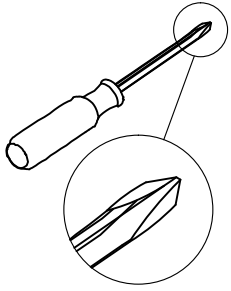

STEP 8

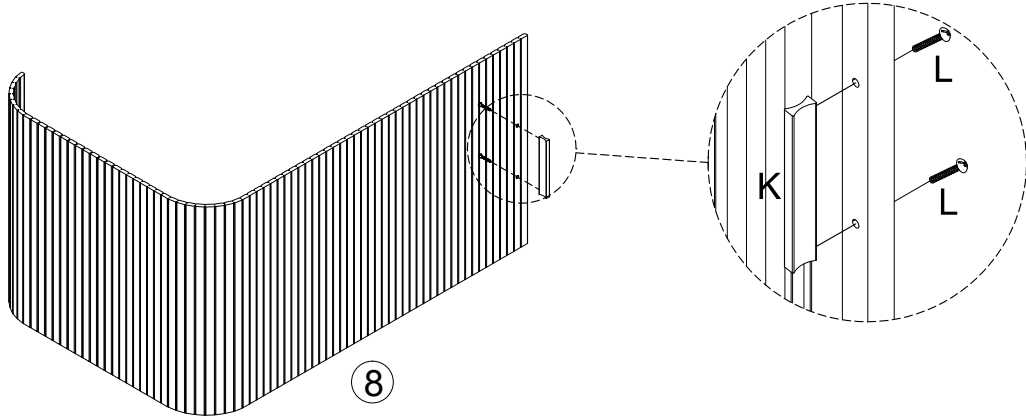
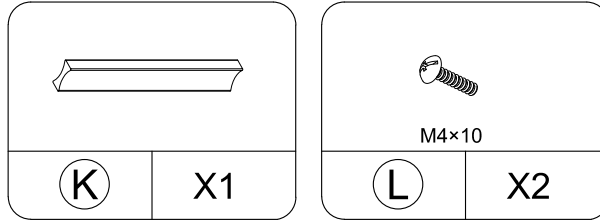
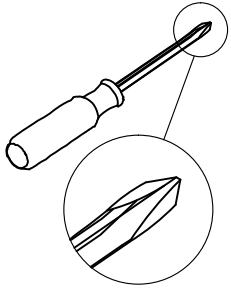

STEP 9

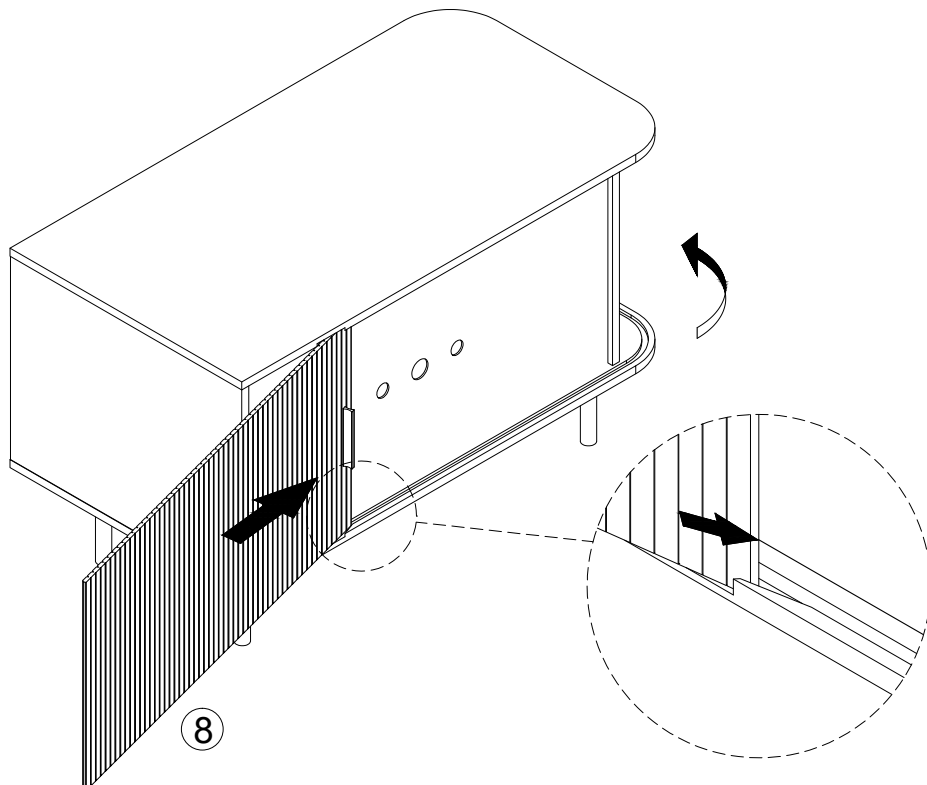

STEP10

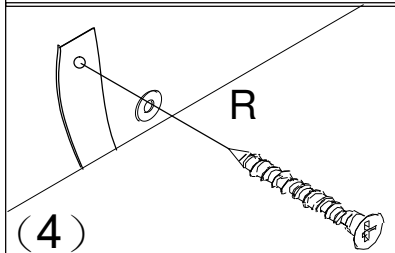
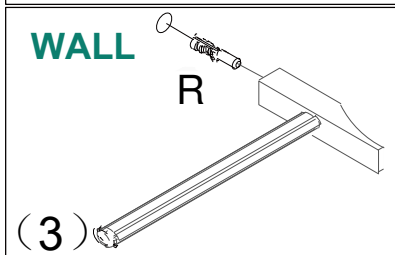
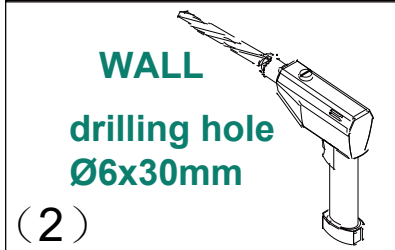
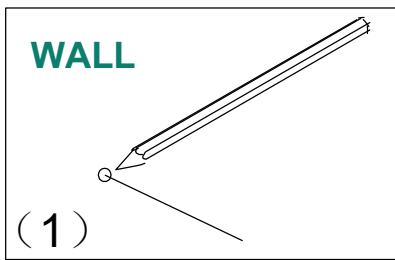
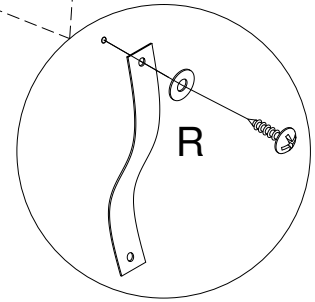
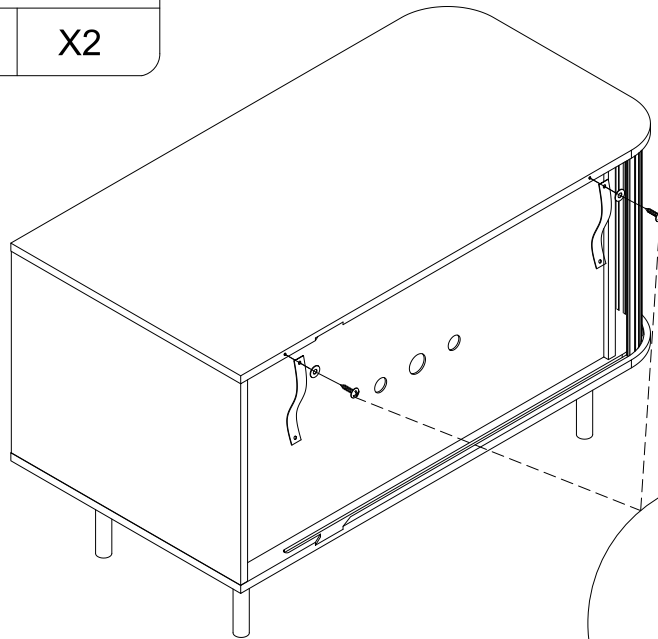
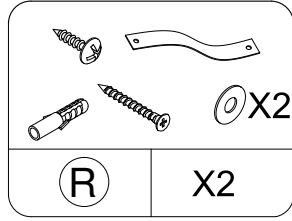
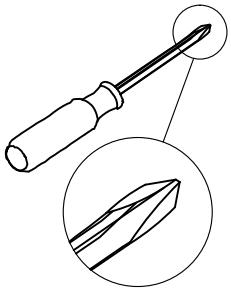

Please push and pull the door several times, it will go more smoothly.

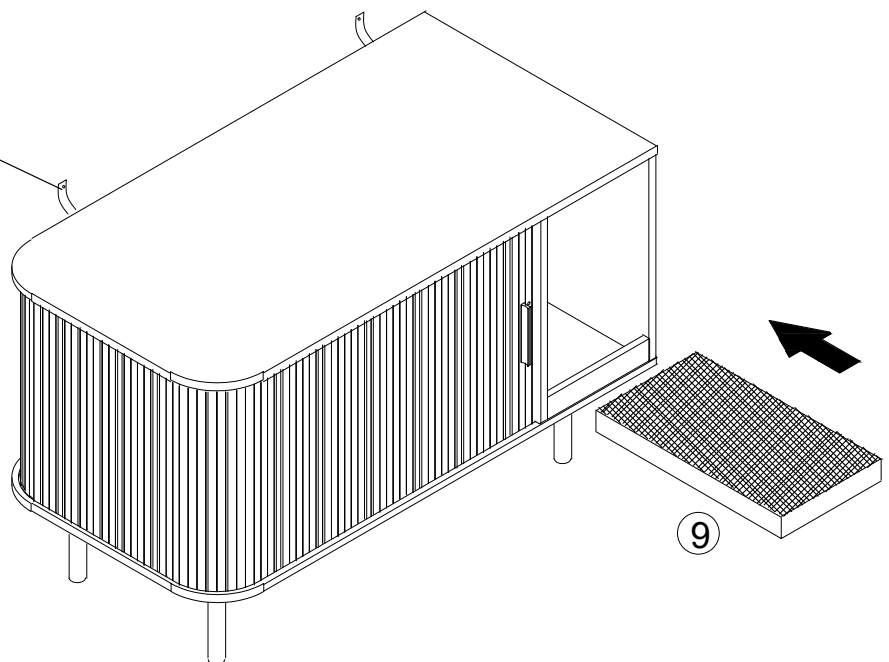

⚠ WARNING



Children have died from furniture tipover. To reduce the risk of furniture tipover:

- ALWAYS install tipover restraint provided.
- NEVER put a TV on this product.
- NEVER allow children to stand, climb or hang on drawers, doors, or shelves.
- NEVER open more than one drawer at a time.
- Place heaviest items in the lowest drawers.
- Do not defeat or remove the drawer interlock system.

This is a permanent label.
Do not remove!

⚠ ATTENTION



Des enfants sont morts du basculement des meubles. Pour réduire le risque de basculement des meubles:

- TOUJOURS installer la retenue de basculement fournie.
- NE JAMAIS mettre de téléviseur sur ce produit.
- NE JAMAIS permettre aux enfants de se tenir debout, de grimper ou de s'accrocher à des tiroirs, des portes ou des étagères.
- N'ouvrez JAMAIS plus d'un tiroir à la fois.
- Placez les objets les plus lourds dans les tiroirs les plus bas.
- Ne désactivez pas et ne retirez pas le système de verrouillage du tiroir.

Ceci est une étiquette permanente.
Ne pas enlever!

⚠ WARNUNG



Kinder sind an einem Möbelkipp gestorben. So verringern Sie das Risiko eines Umkippens von Möbeln:

- Installieren Sie IMMER die mitgelieferte Kipprückhaltevorrichtung.
- Stellen Sie NIEMALS einen Fernseher an dieses Produkt.
- Lassen Sie Kinder NIEMALS an Schubladen, Türen oder Regalen stehen klettern oder hängen.
- Öffnen Sie NIEMALS mehr als eine Schublade gleichzeitig.
- Legen Sie schwerste Gegenstände in die untersten Schubladen.
- Besiegen oder entfernen Sie das Schubladenverriegelungssystem nicht.

Dies ist ein dauerhaftes Etikett.
Nicht entfernen!