











Assembly Instructions

Caution : You must read this before you proceed

Care & Maintenance

- ⊘  ● Not for commercial use. For residential use only.
- ⊘  ● Do not put hot items directly on furniture surface.
- ⊘  ● Do not clean furniture with harsh cleansers or polish.
- ⊘  ● Do not place furniture under direct sunlight.
- ⊘  ● Do not place furniture near heating or cooling vents.
- ⊘  ● Do not write on furniture without a padded barrier to protect the surface.
- ⊘  ● Do not place furniture outside . For indoor use only.
- ⊘  ● Stains may be removed with mild soap solution and damp cloth.
- ⊘  ● Children should not climb or jump on the furniture.
- ✓  ● Dust and pick-up spills using a clean, non-colored, lint-free cloth.

King Bed

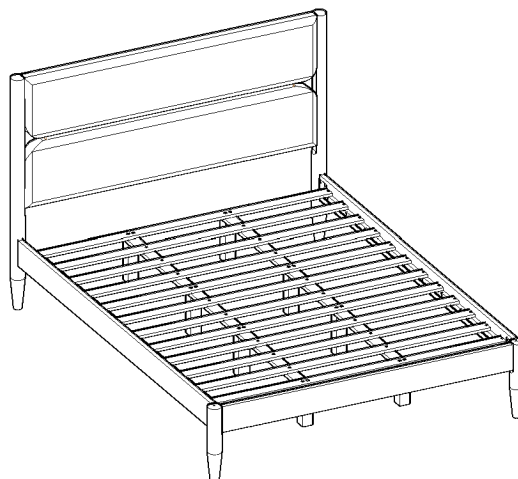

WARNING

STRANGULATION HAZARD.

NEVER place bed near windows where cords from blinds or drapes may strangle a child.
 NEVER suspend strings over bed.
 NEVER place items with a string, cord, or ribbon, such as hood strings or pacifier cords, around a child's neck. These items may catch on bed parts.
 ALWAYS follow assembly instructions.

WARNING!

Not intended for children under the age of six. INFANTS HAVE DIED FROM BECOMING ENTRAPPED IN BEDS. Openings in and between bed parts can entrap the neck and head of a small child. NEVER use bed for child under the age of six.

The mattress must be appropriately sized for the bed. If the mattress is undersized, dangerous gaps can exist and a person can become entrapped or entangled in the frame and suffocate.



NOTE: This Bed is NOT a TOY.

Keep your child/children at bay during the assembly process.

The BED is HEAVY.



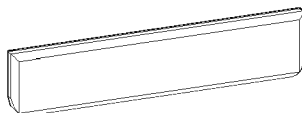
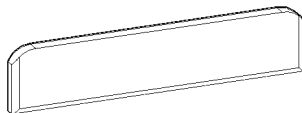
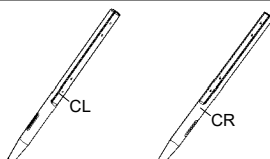

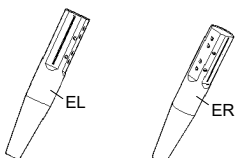
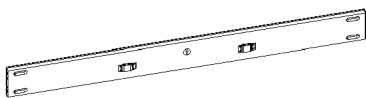
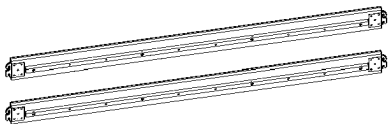

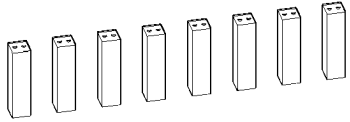
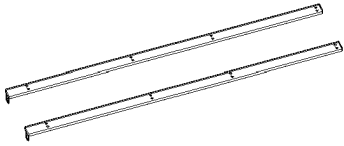
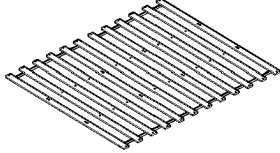
To prevent injury to yourself or damage to the product a minimum of two adults are required whenever moving or lifting it.

Parts List

Label	Picture	Description	QTY
A		Headboard A	1
B		Headboard B	1
C		Headboard Leg	2
D		Headboard Wood	1
E		Footboard Leg	2
F		Footboard	1
G		Side Panel	2

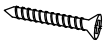
H		Center Leg	8
I		Center Rail	2
J		Slats	12 (2set)

Hardware

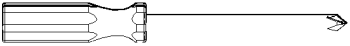
Label	Picture	Description	QTY
①		M4 Allen Wrench (Long Ball Head)	1
②		Bolt (M6x40mm)	19
③		Bolt (M6x50mm)	17
④		Screw (M4x25mm)	41
⑤		Screw (M3.5x16mm)	3
⑥		Spring Washer (M6)	19
⑦		Flat Washer (M6)	15
⑧		Wood Dowel (M8x30mm)	5
⑨		Screwdriver (Not provided)	1

Assembly Preparation

Before Beginning Assembly:

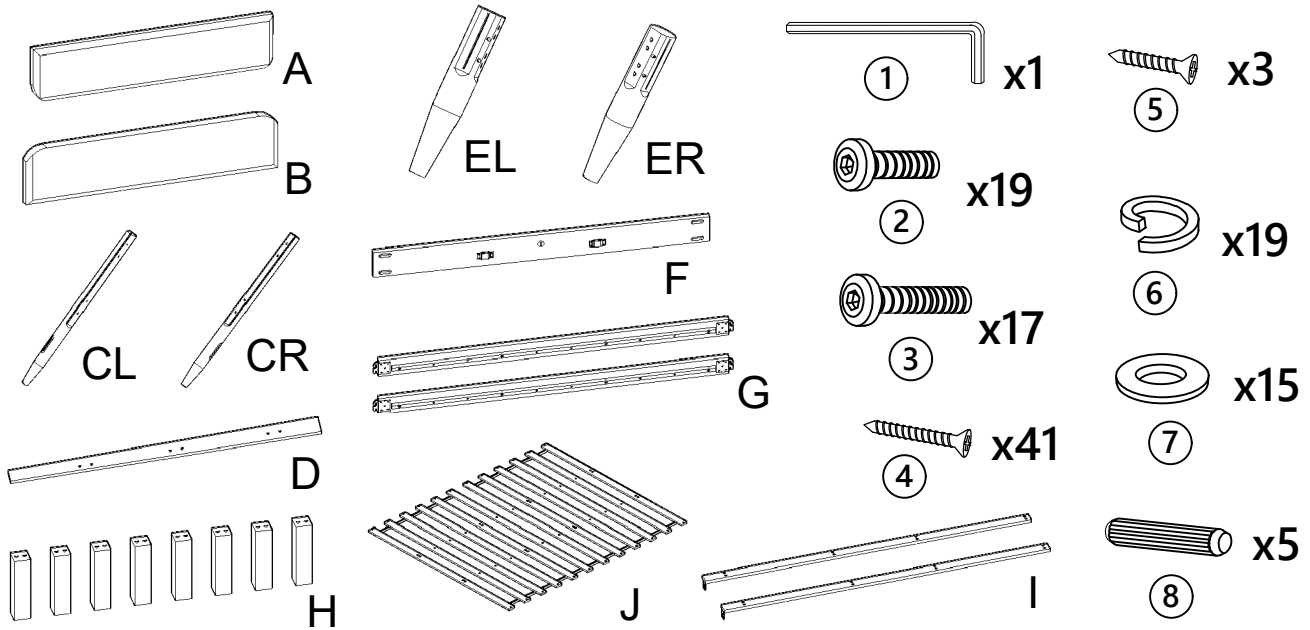

- Read instructions, cover to cover-
- Have 2 adults on hand for assembly-
- Do not assemble on flooring or carpet-
- Assemble on a clean non-marring surface (packing foam)-
- Save all packaging until finished-

Assembly Steps

Overview

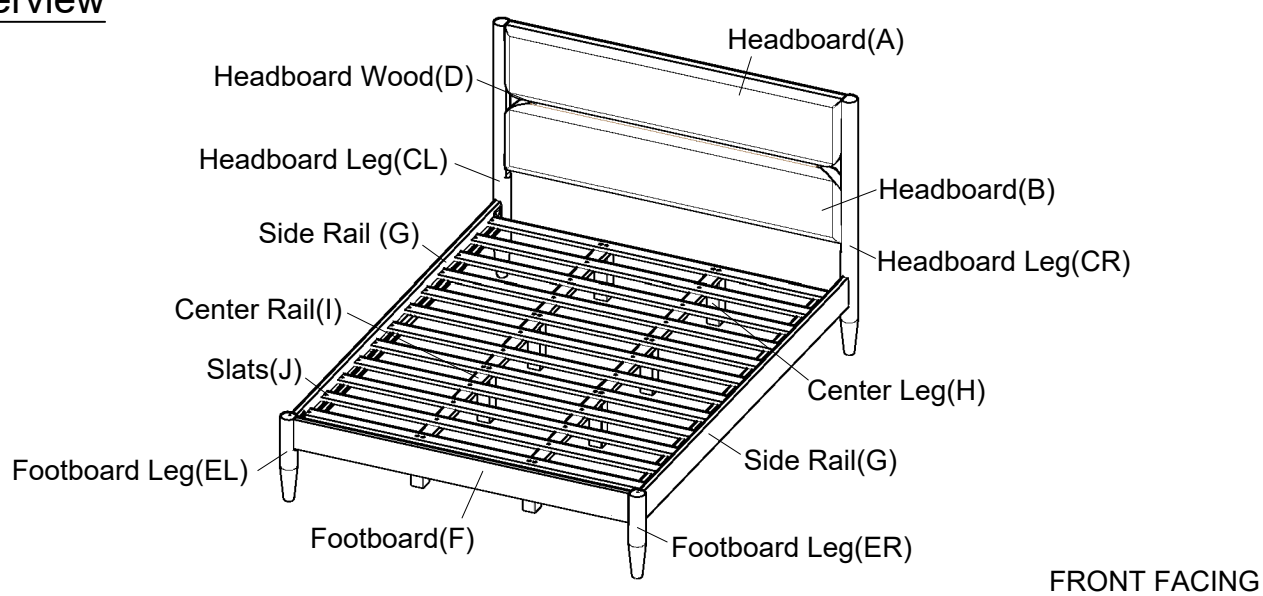

This Bed has multiple parts and may require up to 30 minutes to assemble. To give you an overview of the Bed parts, the above picture is provided to help you put the various parts into perspective. Please read through the instructions below to familiarise yourself with the parts and steps before assembly.

Step 1

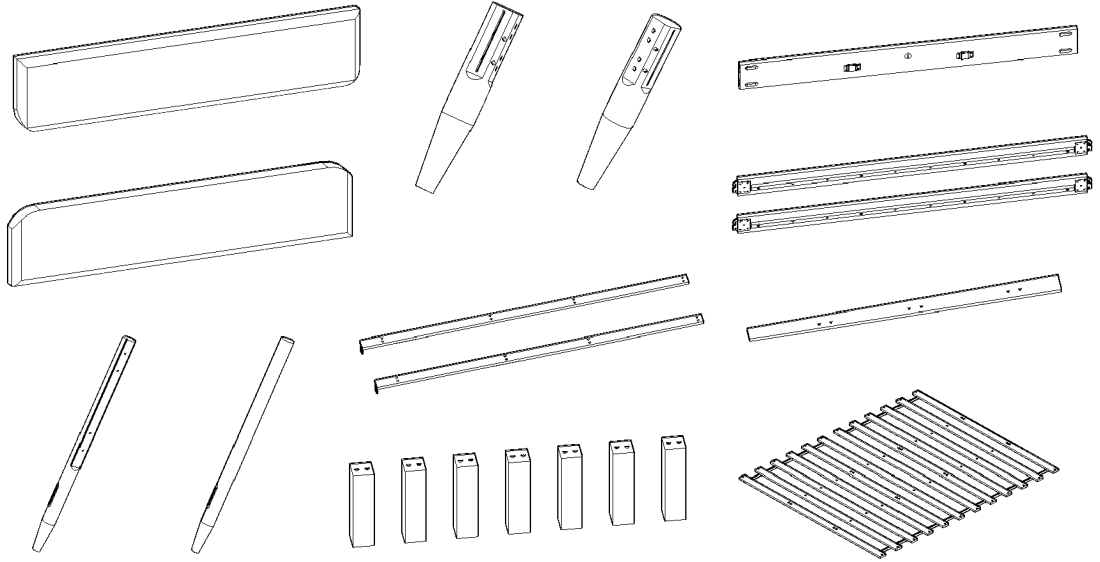

Unpack and place all parts on a clean, non-marring surface.

Step 2

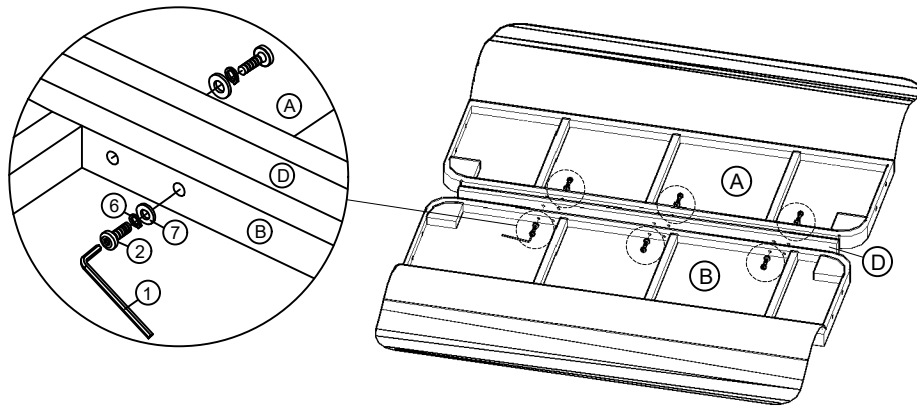

Place the Headboard (A), Headboard (B) with its inner side face skywards onto a clean, soft surface to avoid any scratches or damages to the product.

Align the Mounting Position of Headboard Wood (D) into the Mounting Position of Headboard (A) and Headboard (B) as shown above.

Then, affix the Headboard Wood (D) with Headboard (A) and Headboard (B) by using Bolts (2), Spring Washers (6), Flat Washers (7) with M4 Allen Wrench (1).

Step 3

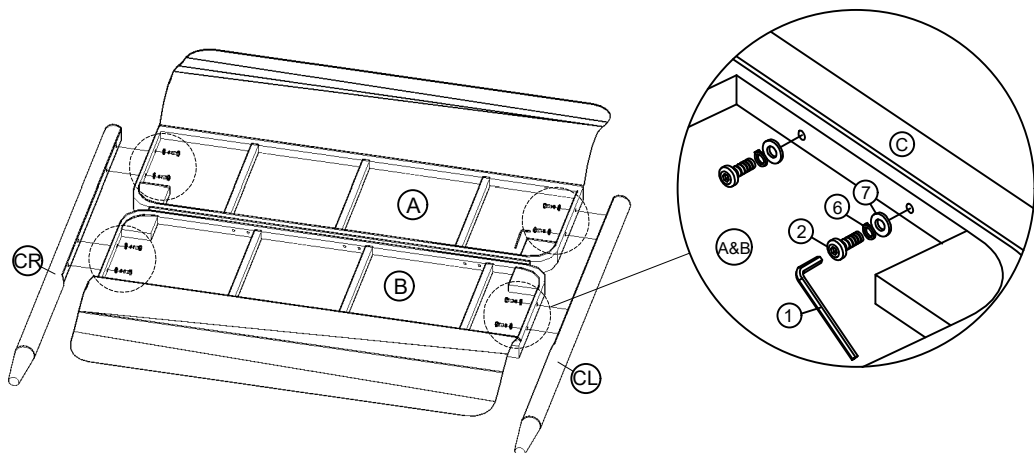

Align the Mounting Position of Headboard Leg (C) into the Mounting Position of Headboard (A) and Headboard (B) as shown above.

Attach the Headboard Leg (C) to Headboard (A) and Headboard (B) by using using Bolts (2), Spring Washers (6), Flat Washers (7) with M4 Allen Wrench (1).

Step 4

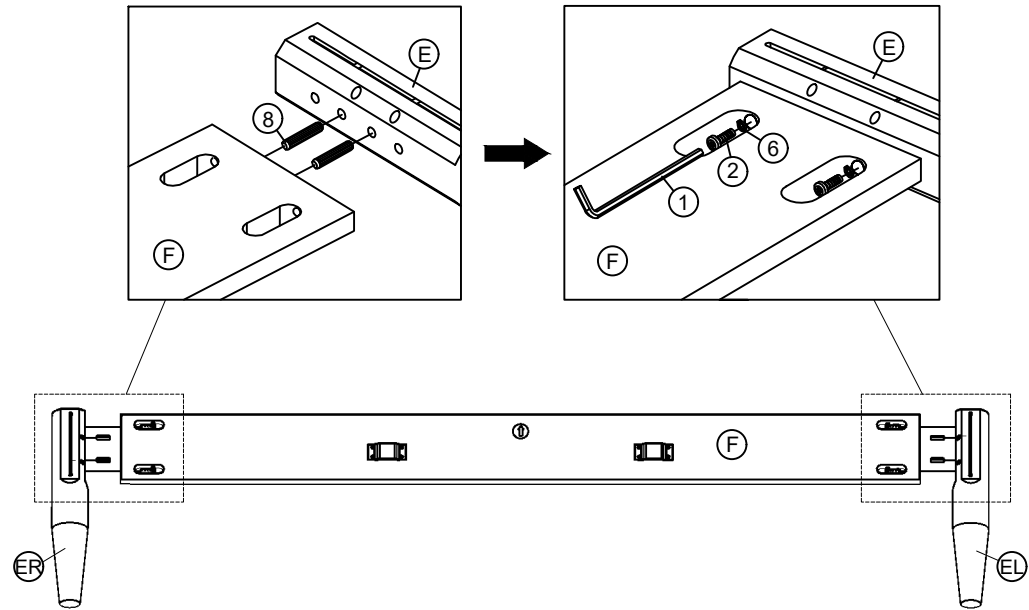

Place the Footboard (F) arrows sticker points upward as shown in picture above.

Align the Footboard Leg (E) into the mounting positions in the Footboard (F) .

Then, affix Footboard Leg (E) to Footboard (F) by using Wood Dowel (8), Bolts (2) and Spring Washers (6) with M4 Allen Wrench (1).

Step 5

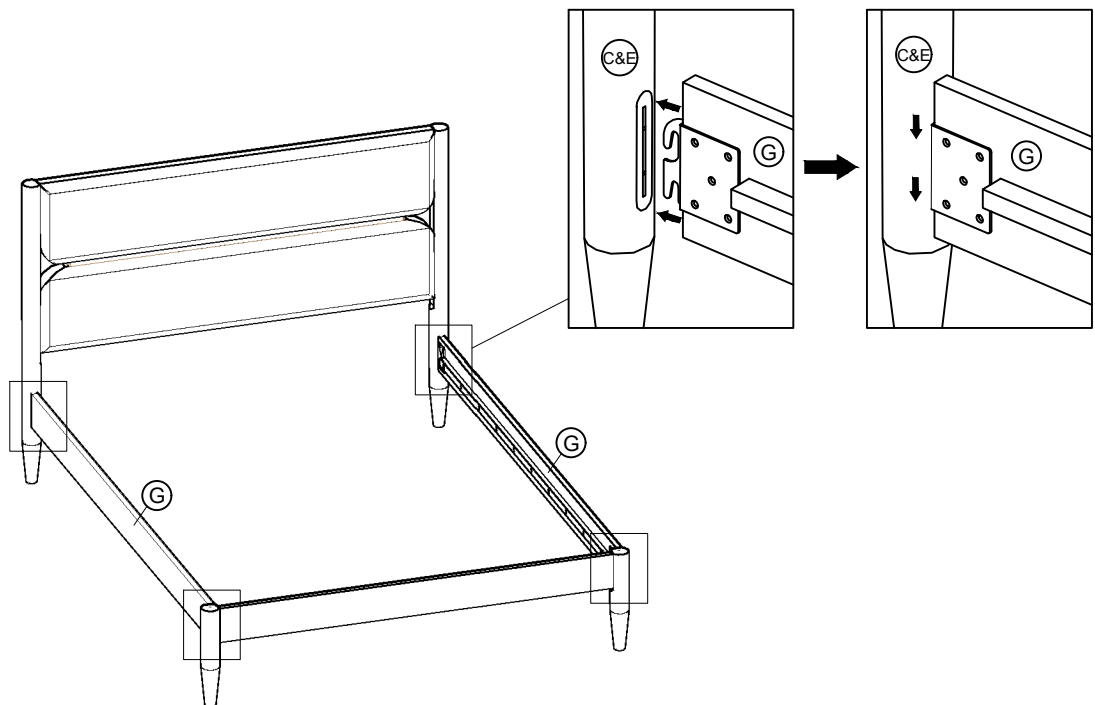

With the help from you partner, stand the assembled headboard(A) and Footboard (F) standing as shown in picture above.

Attach the Side Panel (G) to the assembled headboard(A) and Footboard (F) as shown above.

Step 6

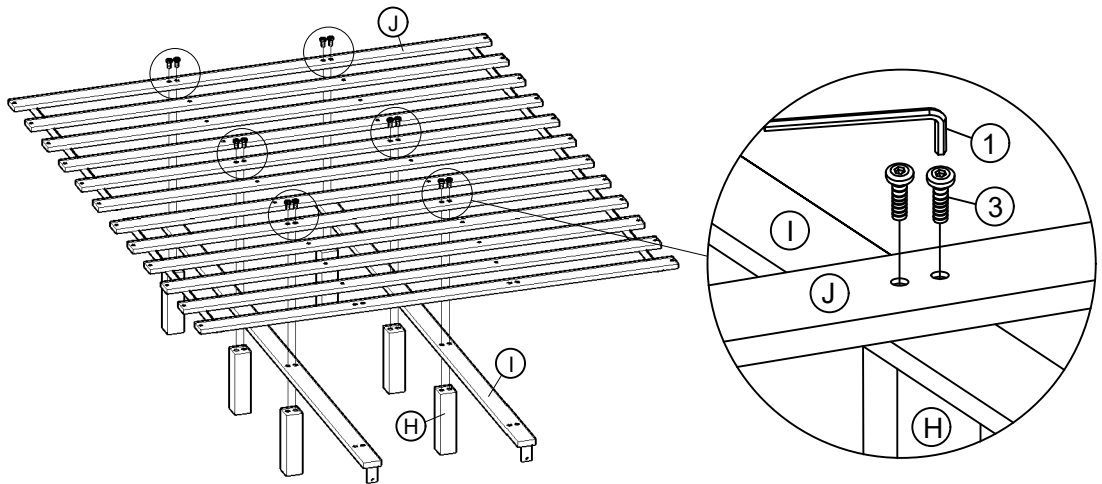

Align the Mounting Position on the Center Rail (I) to the Center Leg(H) and the Slat (J). Attach the Slat (J) and the Center Rail (I) to the Center Leg(H) and by using Bolts (③), with M4 Allen Wrench (①).

Only attach the 6pcs Center Legs(H) on this step, 2pcs mounting position near iron panel on Center Rail (I) will be assembled on Step8.

DO NOT FULLY TIGHTEN BOLTS IN ONE GO, TIGHTEN THE BOLTS AFTER 6PCS Center Legs (H) ARE ATTACHED.

Step 7

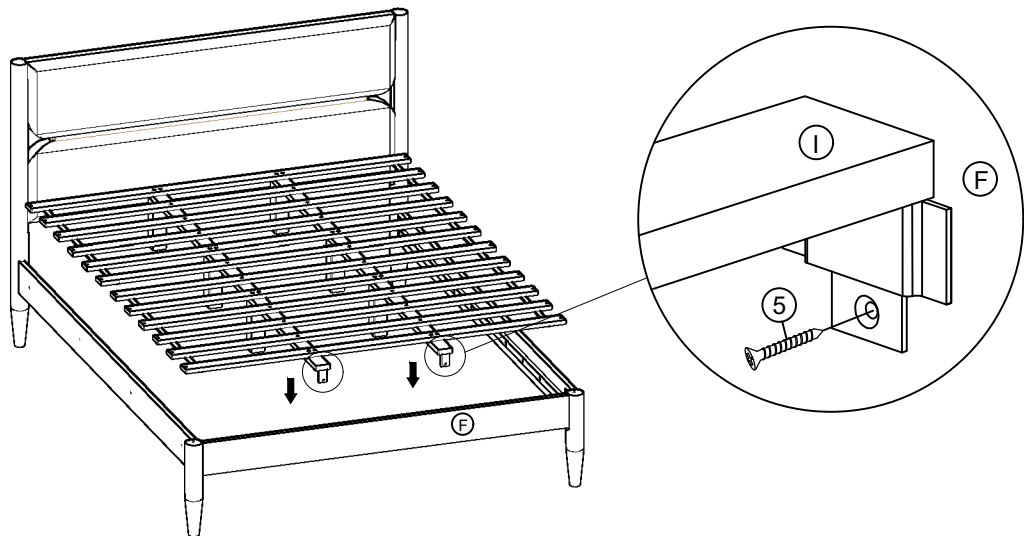

With the help from you partner, place the assembled Slats in the middle of the bed frame. Attach the Assembled Center Rail (I) to the Footboard (F) by using Screws (⑤) and Screwdriver (Not Provided).

DO NOT FULLY TIGHTEN BOLTS.

Step 8

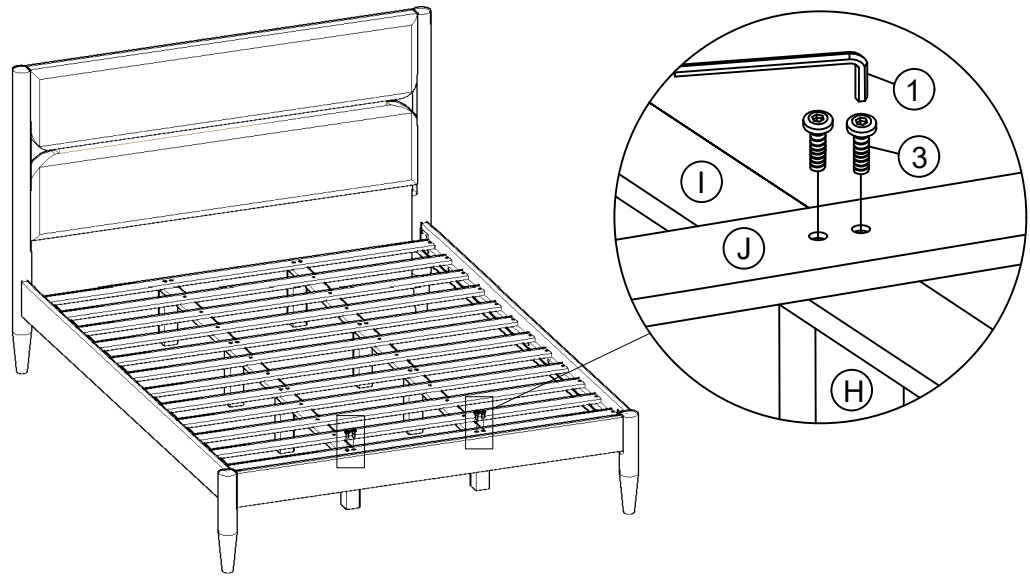

Attach the balanced Center Leg(H) to Assembled Slat (J) and the Center Rail (I) and by using Bolts (3), with M4 Allen Wrench(1).

Step 9

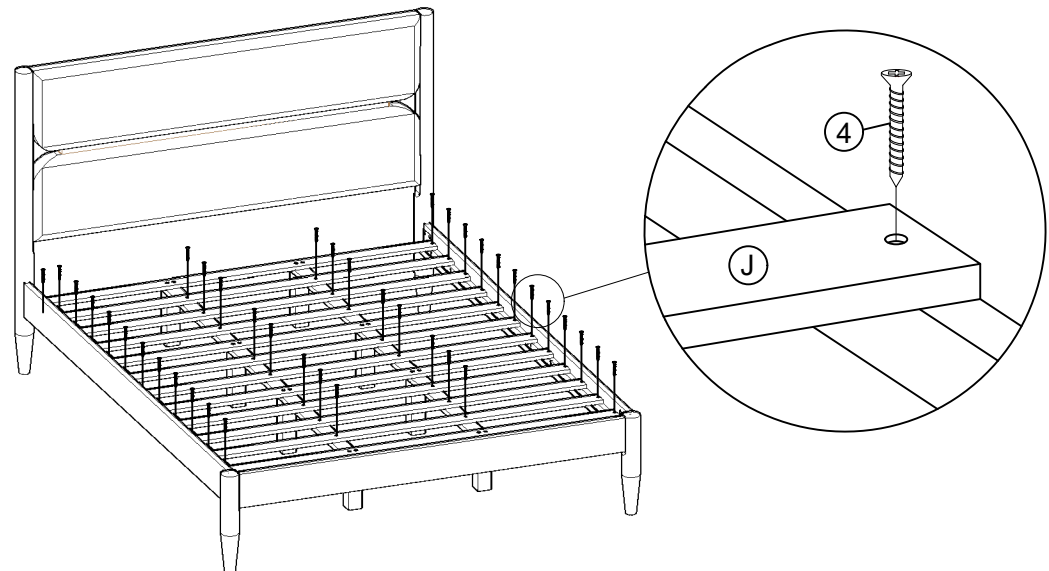

Attach all slats (J) to the rail on Side Panel (G) by using Screws (4) and Screwdriver (Not Provided).

Step 10

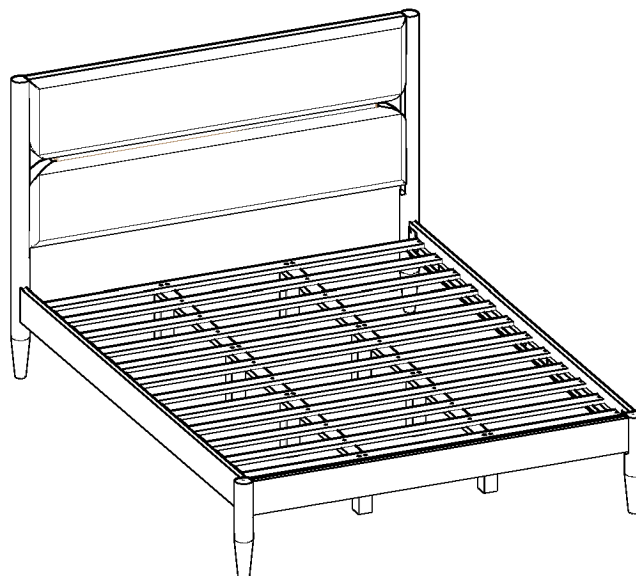

Place the Bed on a LEVEL SURFACE.

Inspect it and make sure all parts are adequately connected.

Don't push too hard, shake on the bed.

This would help to align all the parts at all the joint areas.

CAUTION 1: When tightening these screws, tighten sequentially.

DO NOT tighten any screw fully and then towards the next one.

This would cause the frame to warp.

If there is still wobbles, loosen the screws and execute this same process. DO NOT tighten any screw fully and then towards the next one.

WARNING!! IF BED IS NOT STABLE , IT COULD LEAD TO DAMAGING THE PRODUCT.

Ensure all screws are fully locked into position.

The bed is ready to be used.

Caution 2: This bed can only be used on a flat, level surface.