

CARE AND MAINTENANCE







Wipe clean with a soft, dry cloth. Test the cleaning method on a hidden area before using them over the entire area.

NOTICE

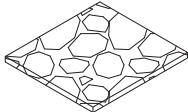
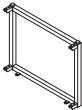
- * Please make sure that you have all parts indicated before you begin assembly of this item.
- * This item should be assembled on a soft surface to prevent scratching the finished product during assembly.
- * This item may require periodic tightening.
- * Do not tighten bolts until completely assembled.

Product Dimensions: 19-5/8"Wx19-5/8"Dx20-1/2"H

Part List and Hardware List

PIECE	DESCRIPTION	PICTURE	QUANTITY
A	Top Panel		1x
B	Side Frame		2x
C	Side connecting bar		2x
D	Bottom connecting bar		2x
H1	Allen Bolt	 1/4"x 5/8"	16x
H2	Wood Screw	 Ø8x15mm	8x
H3	Allen Key	 M4	1x

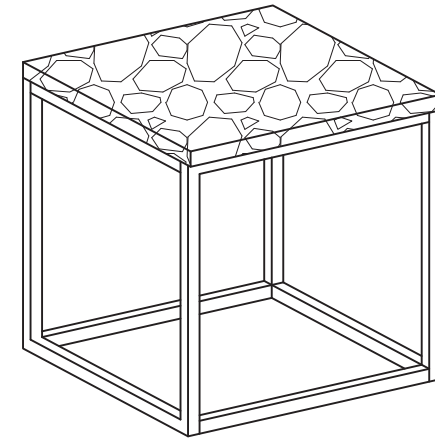

Weight capacity:25lbs
WARNING:DO NOT STAND ON TABLE
WARNING:DO NOT OVER TORQUE BOLTS

PREPARATION

Before beginning assembly of product, make sure all parts are present. Compare parts with package contents list and hardware contents list. If any part is missing or damaged, do not attempt to assemble the product.

Estimated Assembly Time: 15 minutes.

Tools Required for Assembly : Allen Key (included) and Philips head screwdriver (not included)

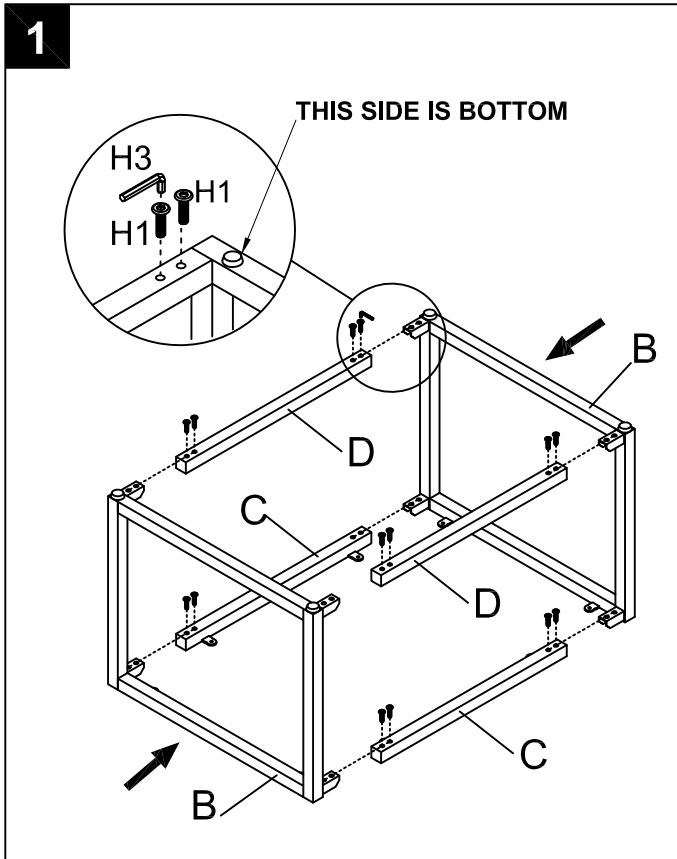

Step 1

Attach 4*connecting bars (2*C & 2*D) to 2*side frame (B), Use Allen Key (H3) to lock through holes on connecting bars with 16*Allen bolts (H1).

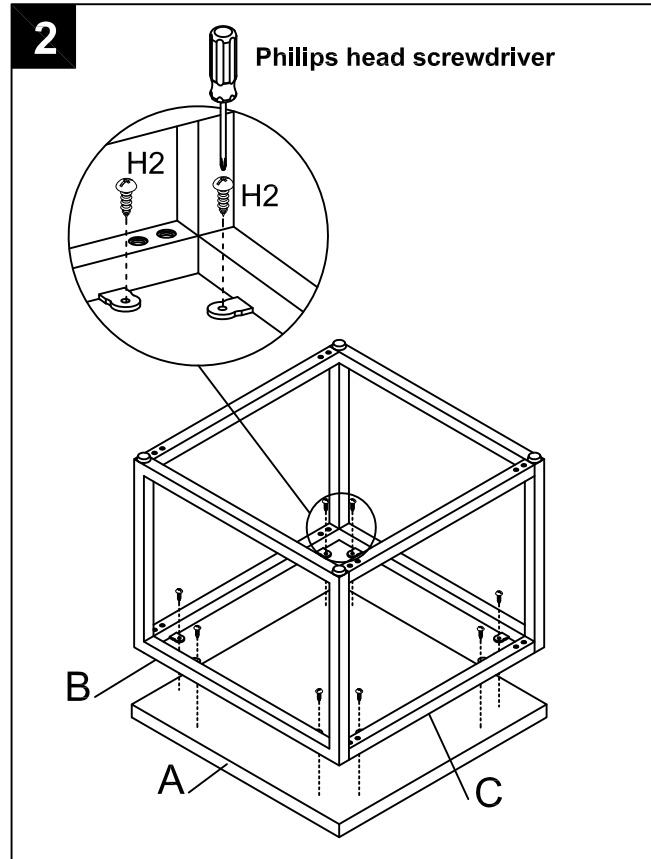

Step 2

Attach the reverse side of top panel (A) to the assembled metal frame, Use Philips head screwdriver (tool is not included) to lock with 8*wood screws (H2), as picture.

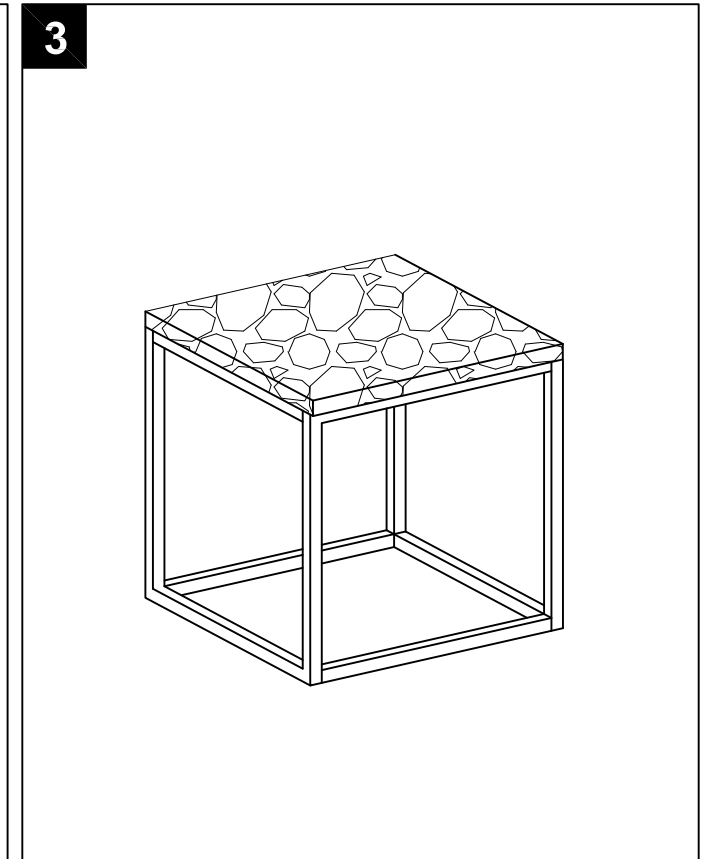

Step 3

Straighten up the assembled table, Assembly is completed.