











Assembly Instructions

Caution : You must read this before you proceed

Care & Maintenance

- ⊘  ● Not for commercial use. For residential use only.
- ✓  ● Furniture may scratch floors. We recommend using furniture pads to protect your floors.
- ⊘  ● Do not put hot items directly on furniture surface.
- ⊘  ● Do not clean furniture with harsh cleansers or polish.
- ⊘  ● Do not place furniture under direct sunlight.
- ⊘  ● Do not place furniture near heating or cooling vents.
- ⊘  ● Do not write on furniture without a padded barrier to protect the surface.
- ⊘  ● Do not place furniture outside . For indoor use only.
- ⊘  ● Stains may be removed with mild soap solution and damp cloth.
- ⊘  ● Children should not climb or jump on the furniture.





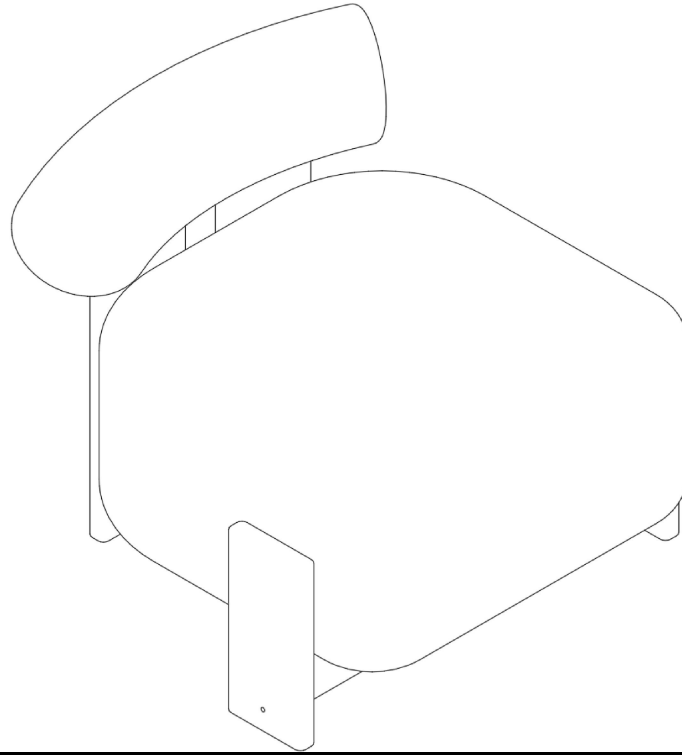

- Dust and pick-up spills using a clean, non-colored, lint-free cloth.

Please look in Leg for hardware pack.

CHAIR

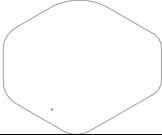

Parts List

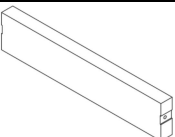
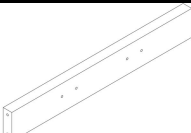
Label	Picture	Description	QTY
A		Back	1
B		Seat	1
C		Left hind leg	1
D		Right hind leg	1
E		Front Leg	2
F		Base support	2
G		Front support	1

Hardware

Label	Picture	Description	QTY
①		Angle iron	5
②		Plate iron	5
③		Bolt (M6*20MM)	17
④		Bolt (M6*30MM)	5
⑤		Spring Washer(M6)	21
⑥		Washer(M6)	23
⑦		Allen Wrench (M6)	1
⑧		Bolt (M8*45MM)	9
⑨		Spring Washer(M8)	9
⑩		Washer(M8)	7
⑪		Allen Wrench (M8)	1
⑫		Wood plugs	3

Assembly Preparation

Before Beginning Assembly:

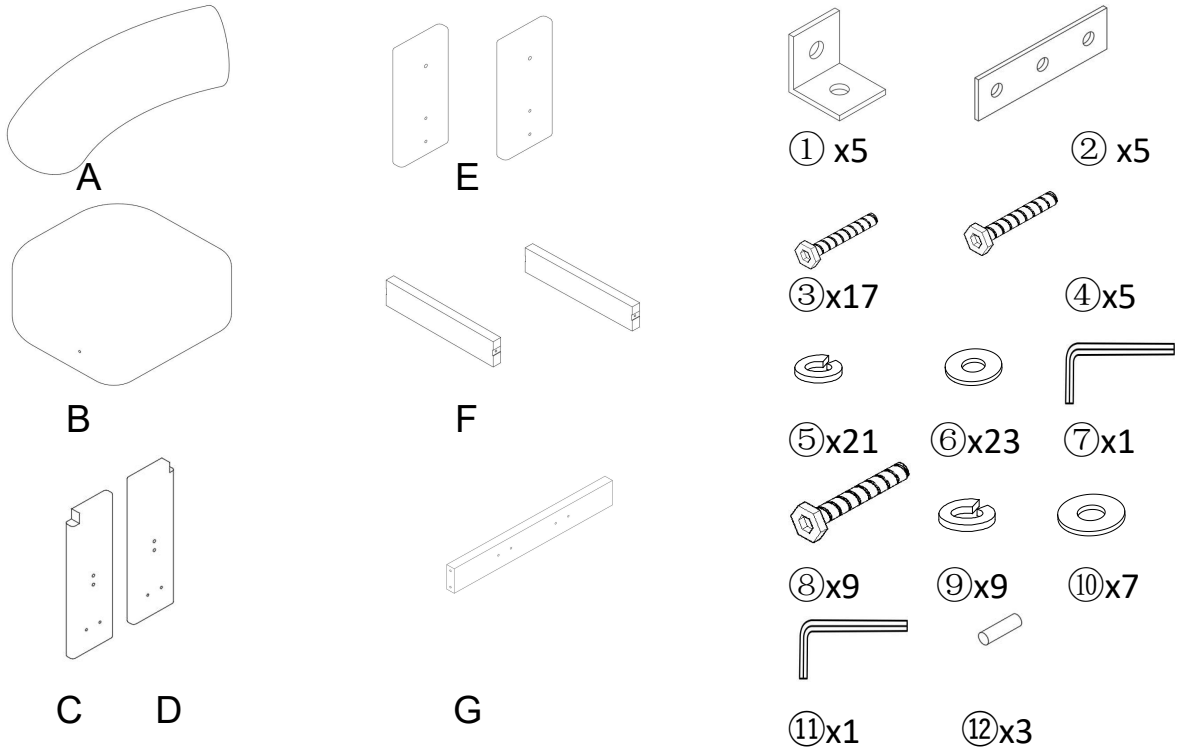

- Read instructions, cover to cover-



- Have 2 adults on hand for assembly-



- Do not assemble on flooring or carpet-



- Assemble on a clean non-marring surface (packing foam)-



- Save all packaging until finished-

Assembly Steps

Overview

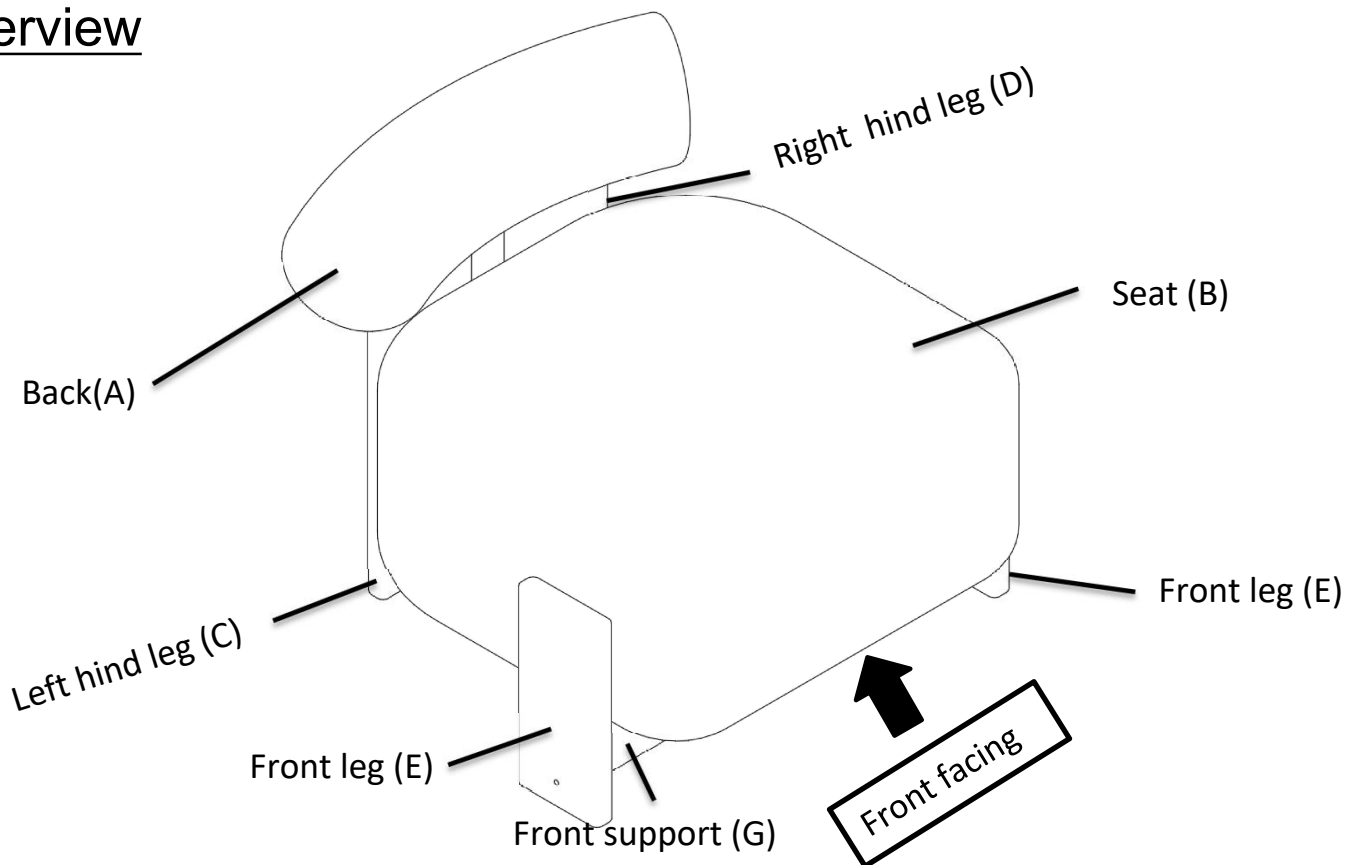

This Chair has multiple parts and may require up to 30 minutes to assemble. To give you an overview of the Chair parts, the above picture is to help you put the various parts into perspective. Please read through the instructions below to familiarise yourself with the parts and steps before assembly.

Step 1

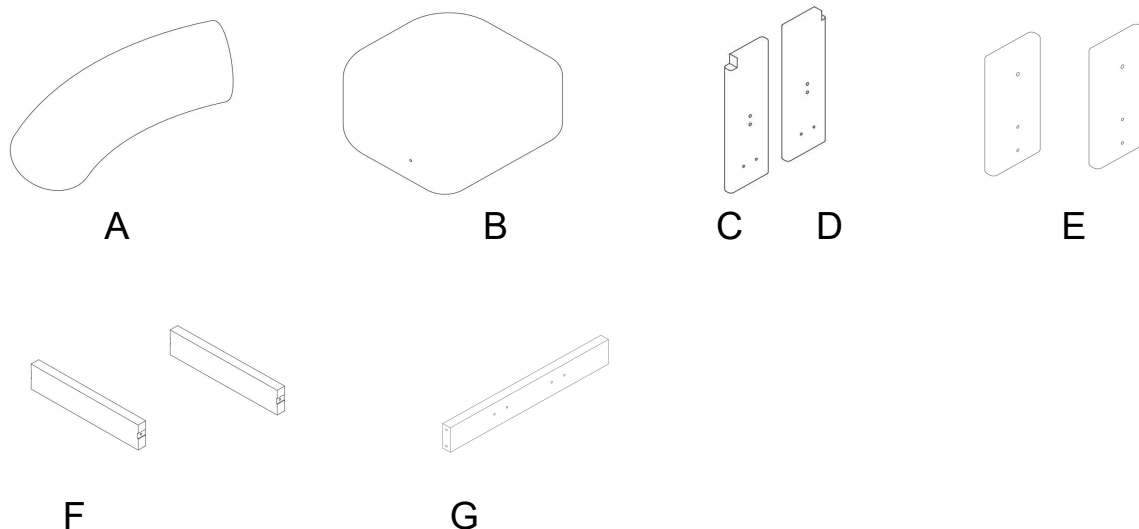

Unpack and place all the parts on a clean, non-marring surface.

Step 2

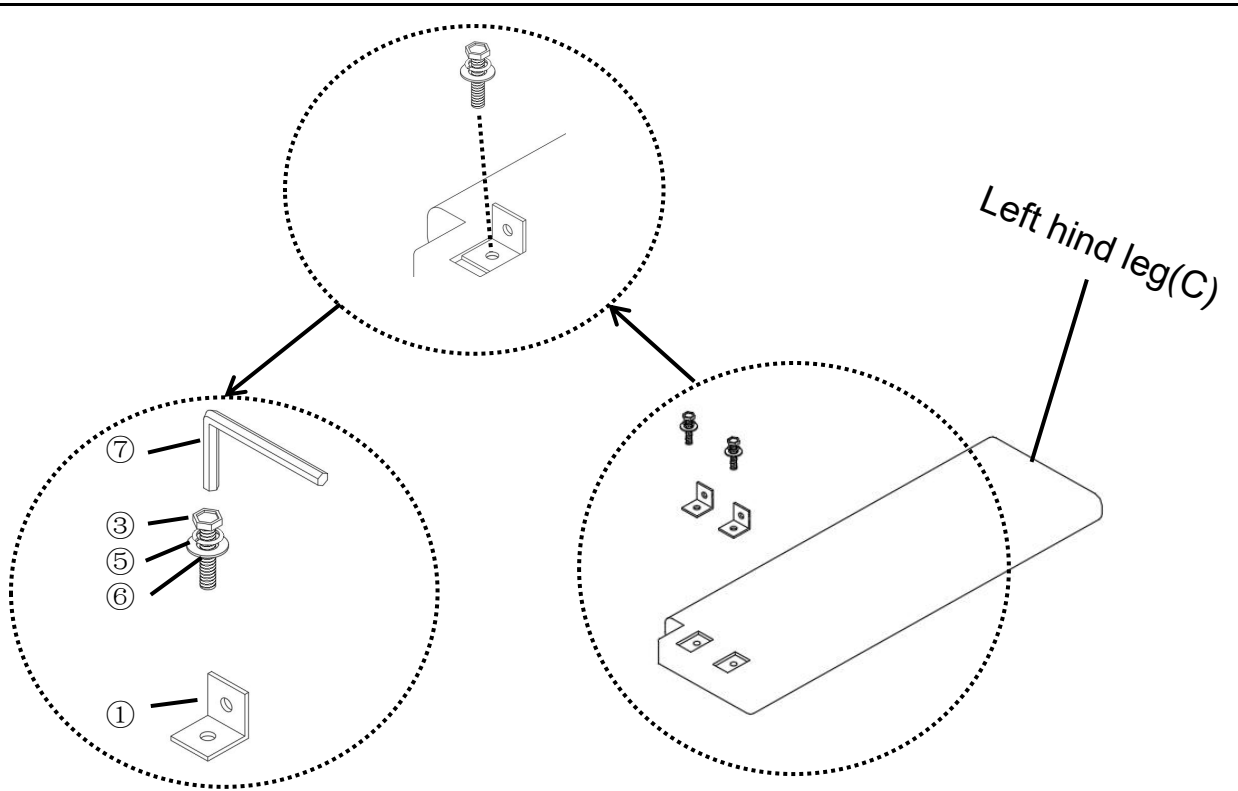

- 2.1) Fix the Angle iron (①) into the mounting position of Left hind leg (C) use Bolt (③), Spring washer (⑤) and Washer (⑥) with Allen wrench (⑦), as shown above.
- 2.2) Repeat the previous step for Right hind leg.
- Do not fully tighten the Bolts.

Step 3

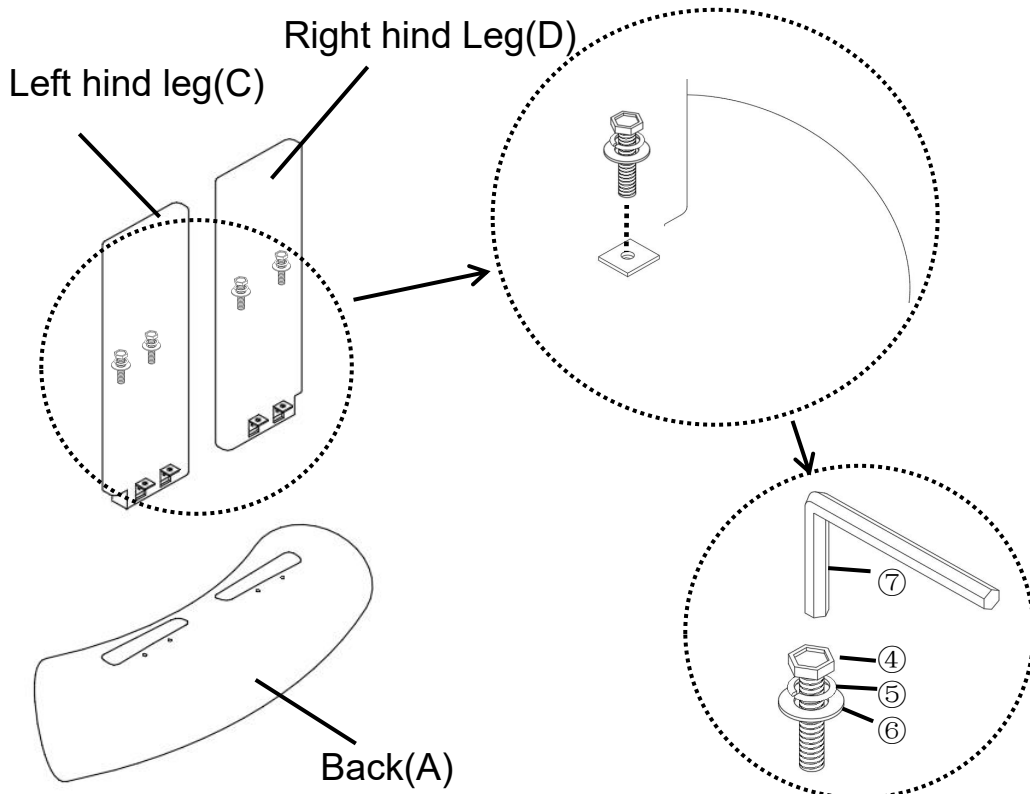

- Slot the Hind legs (C+D) into the slots on the Back (A), as shown in picture. Attach them using bolts (④), Spring washer (⑤) and Washer (⑥) with Allen wrench (⑦).
- Do not fully tighten the Bolts.

Step 4

Seat(B)

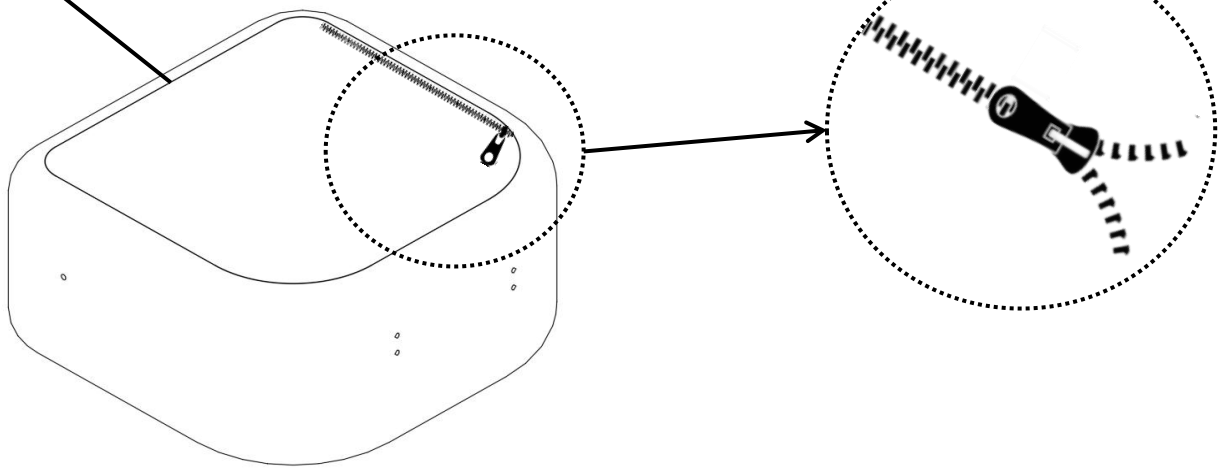

Unzip the seat.

Step 5

Front Leg(E)

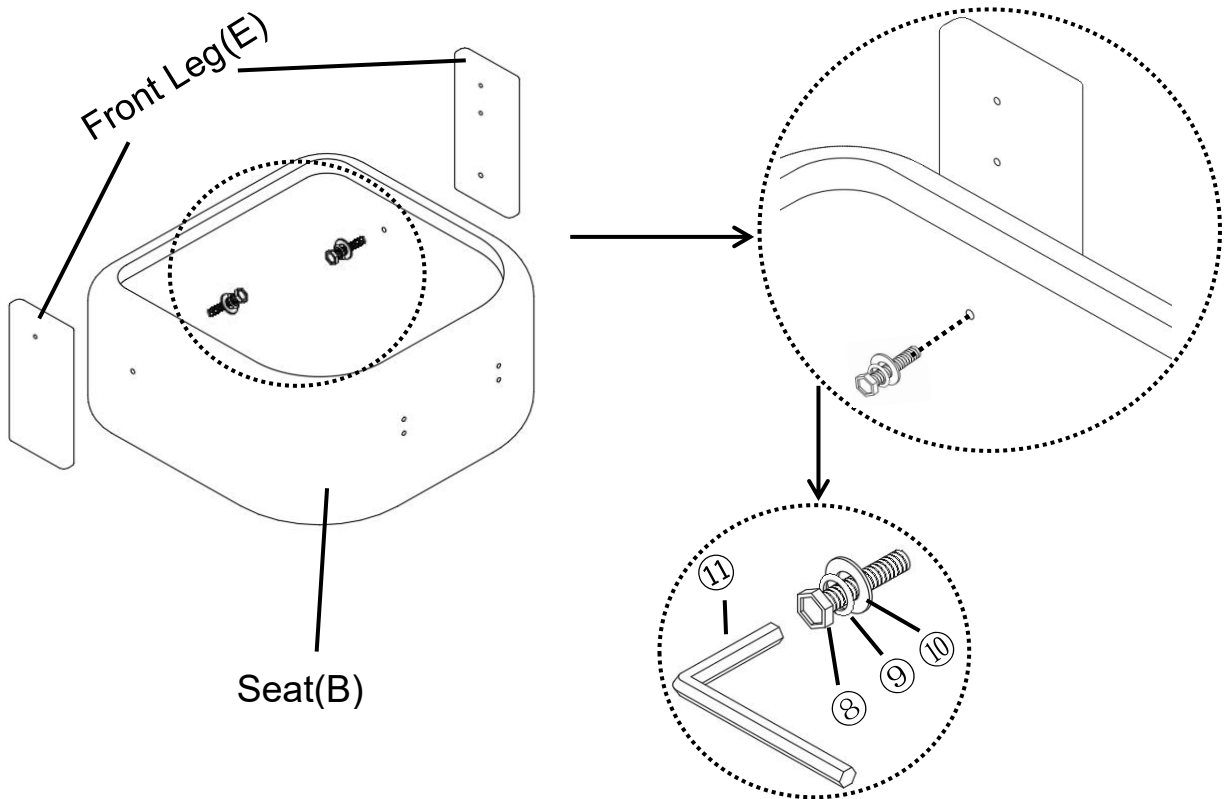

Attach the Front legs(E) into the mounting positions of Seat(B) using Bolts(⑧), Spring washers(⑨) and Washers(⑩) with Allen wrench(⑪).
Do not fully tighten the Bolts.

Step 6

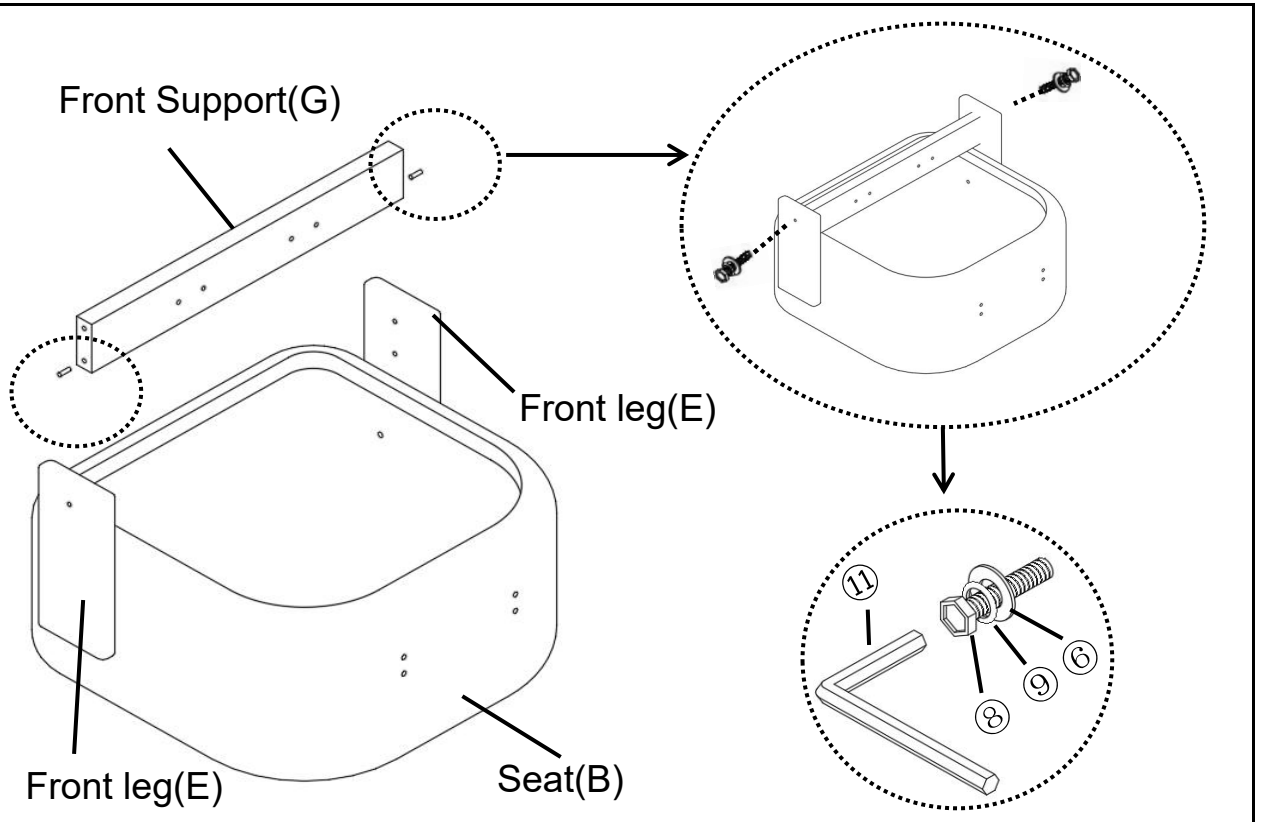

- 6.1) Slot the wood plugs(12) into the position holes on the Front support(G) and slot another end of wood plugs into the position hoels of Front legs(E),as shown bove.
- 6.2)Attach Front legs(E) to Front support(G) using Bolts(8),Spring washer(9) and Washers(6) with Allen wrench(11).

Step 7

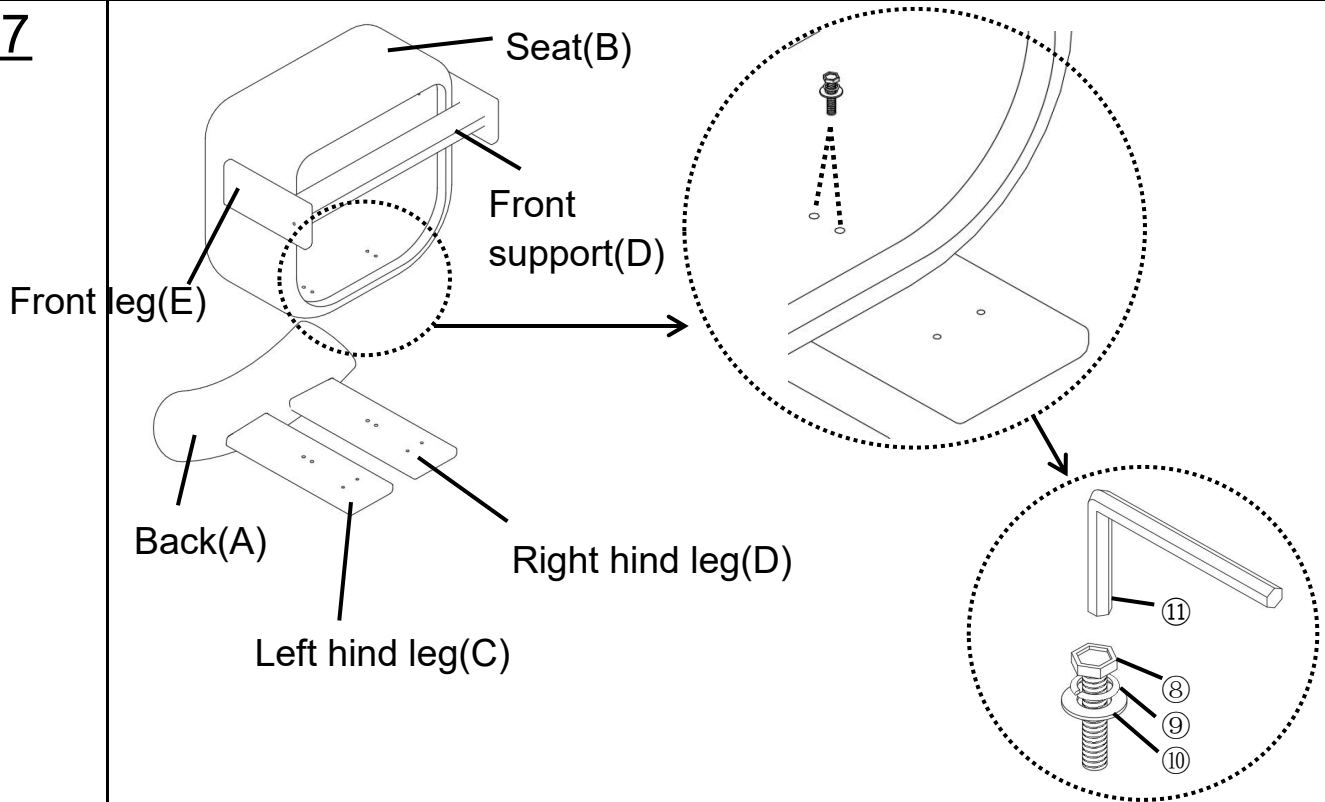

- Attach the Seat(B) into the mounting positions of the Hind legs(C+D) using Bolts(8), Spring washers(9) and Washers(10) with the Allen wrench(11).
Do not fully tighten the Bolts.

Step 8

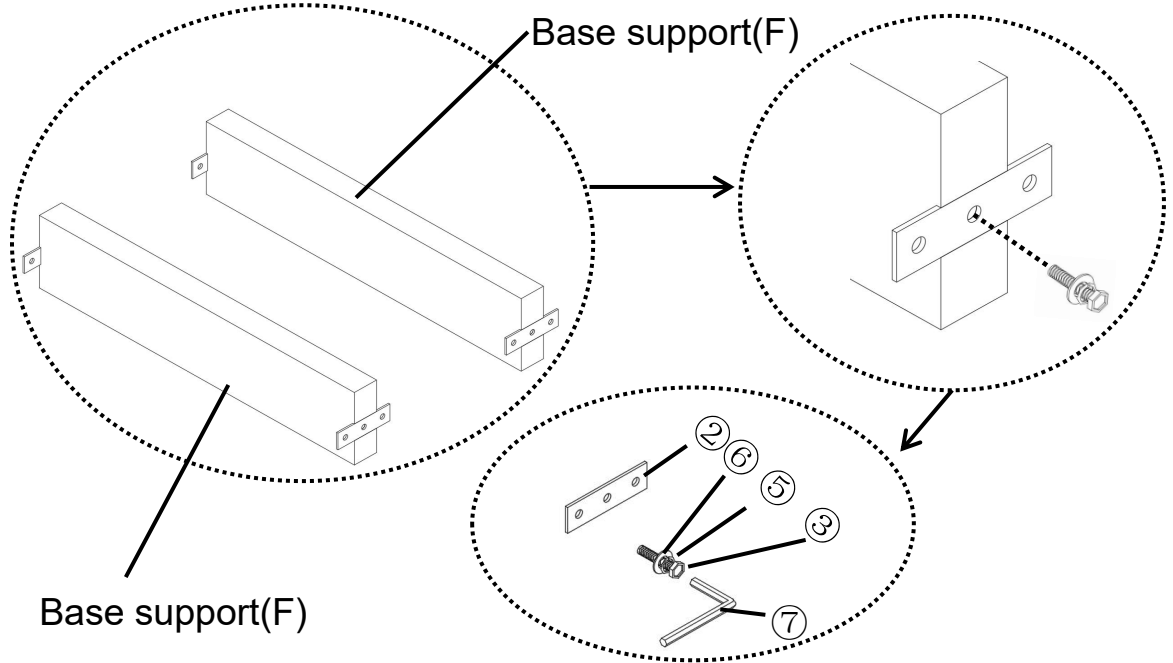

Attach the Plate irons(②) into the mounting positions of the Base supports(F) using Bolts(③), Spring washers(⑤) and washers(⑥) with the Allen wrench(⑦). Do not fully tighten the Bolts.

Step 9

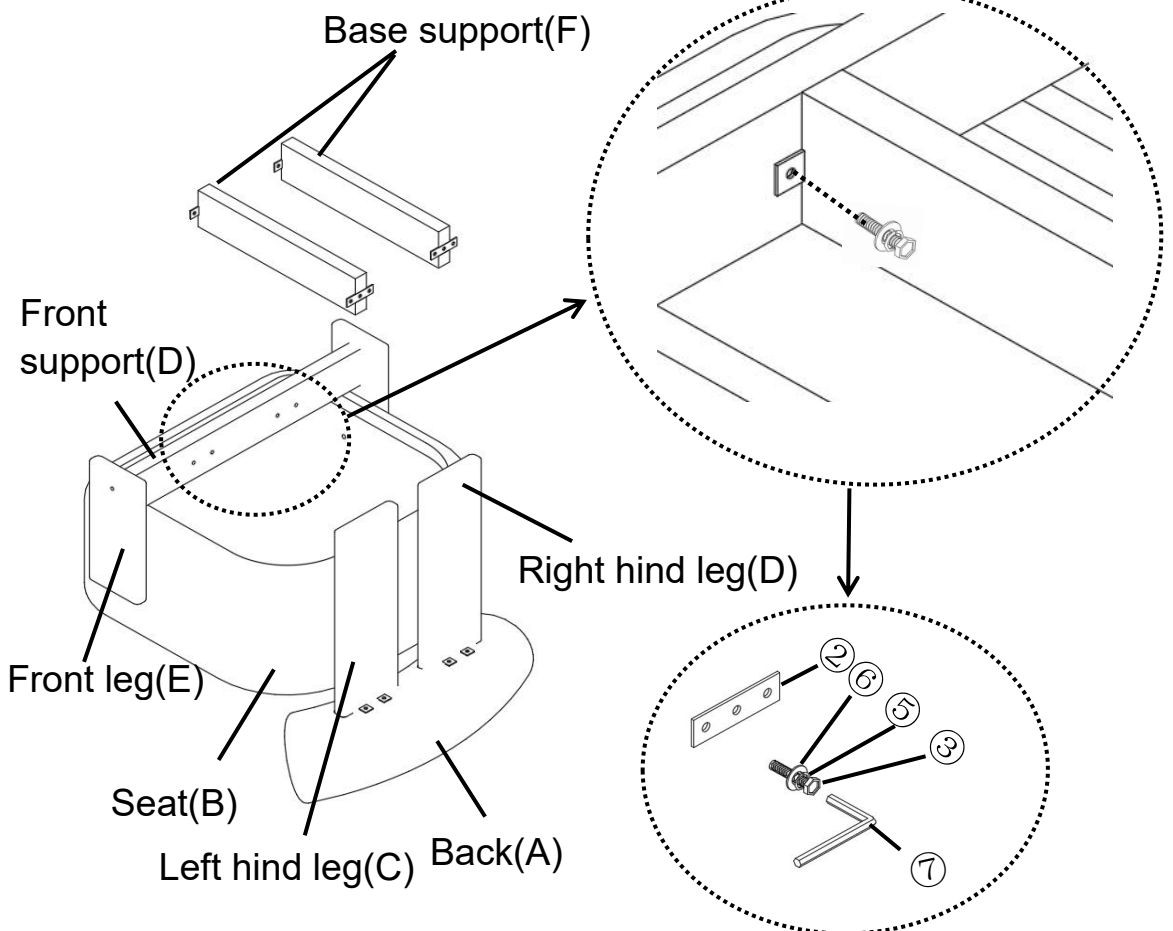

Attach the Plate irons(②) into the mounting positions of the Front support(G) using Bolts(③), Spring washers(⑤) and Washers(⑥) with the Allen wrench(⑦). Do not fully tighten the Bolts.

Step 10

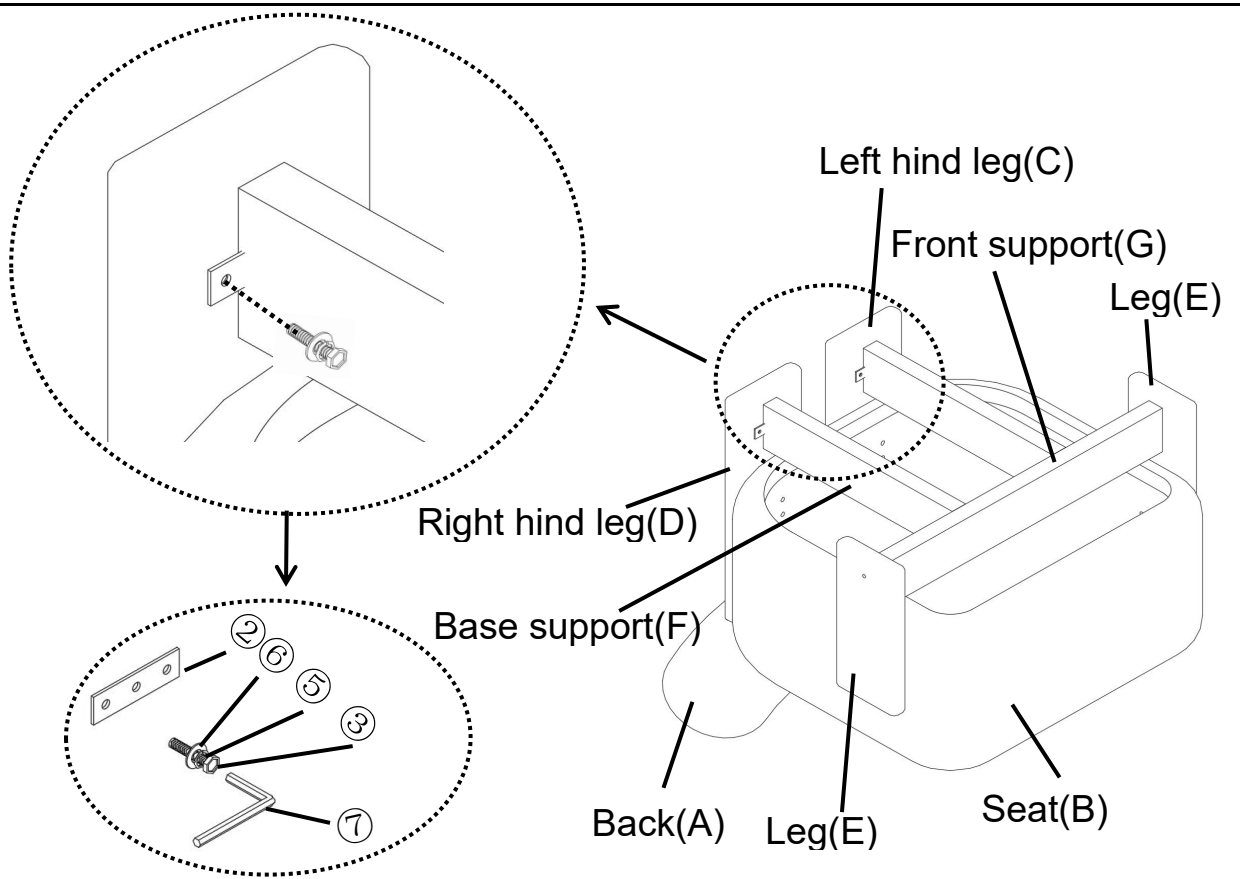

Attach the Plate irons(②) into the mounting positions of the Hind legs(C+D) using Bolts(③), Spring washers(⑤) and Washers(⑥) with the Allen wrench(⑦). Do not fully tighten the Bolts.

Step 11

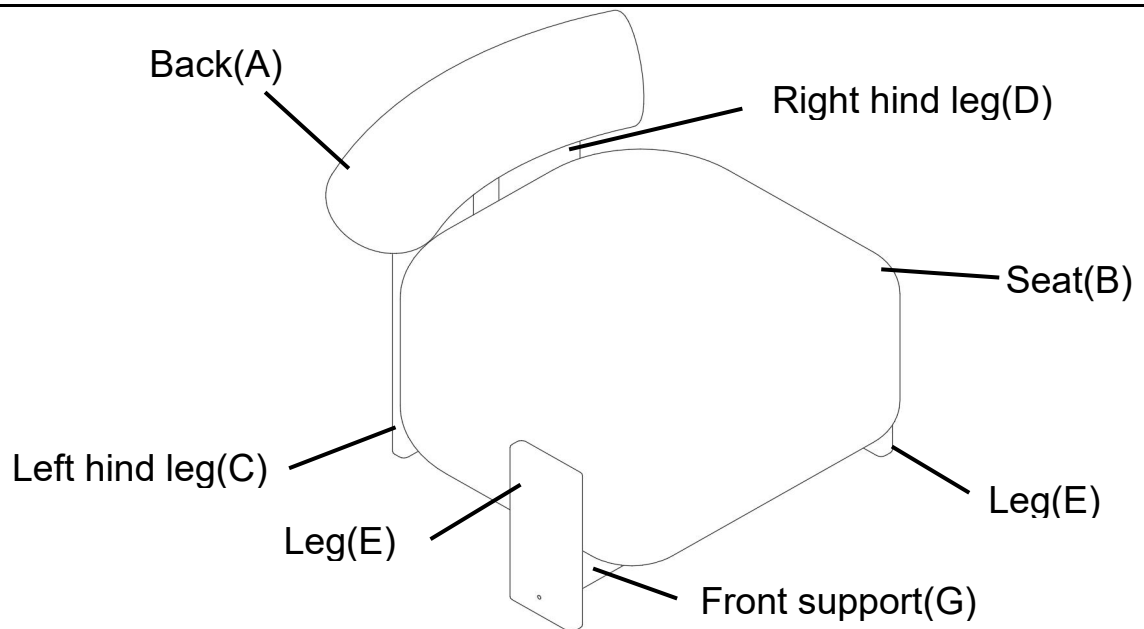

11.1) Tighten all the remaining bolts.

DO NOT fully tighten a bolt in one go and then move on to the next. Rather, in a sequential manner, gradually tighten each bolt until all bolts are evenly secured. This methodology will ensure maximum evenness once all bolts are fully tightened.

11.2) Zip the seat bottom up.

11.3) Turn the Chair right side up, your Chair is ready for use.

This Chair can only be used on a flat, level surface.