

Harbor Table Assembly Guide

Harbor Table Assembly 60" Round (Dining, Counter & Bar Heights)



Dining Height



Counter Height



Bar Height

Hardware Included

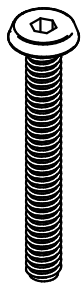

$\frac{1}{4}$ " x 2"
Bolt x8

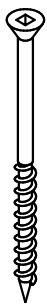

3" Buglehead
Screw

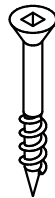

1 $\frac{1}{2}$ " Buglehead
Screw x4



$\frac{1}{4}$ " Flange
Nut x8



Umbrella Knob x2



$\frac{5}{8}$ " Panhead
Screw x16

Tools / Items Needed



Allen Wrench
(Included)



7/16" Wrench



#2 Square Drive Bit



Cordless Drill

Step 1

Open the box containing the Table top on all sides but leave the top laying in the box. Next fasten all cross pieces to 1 base assembly by inserting cross piece tenons into mortises on base assembly and fasten using 3" Buglehead Screws. Repeat assembly on other side with remaining base assembly. *NOTE: Dining Height will only have 1 set of cross pieces.*

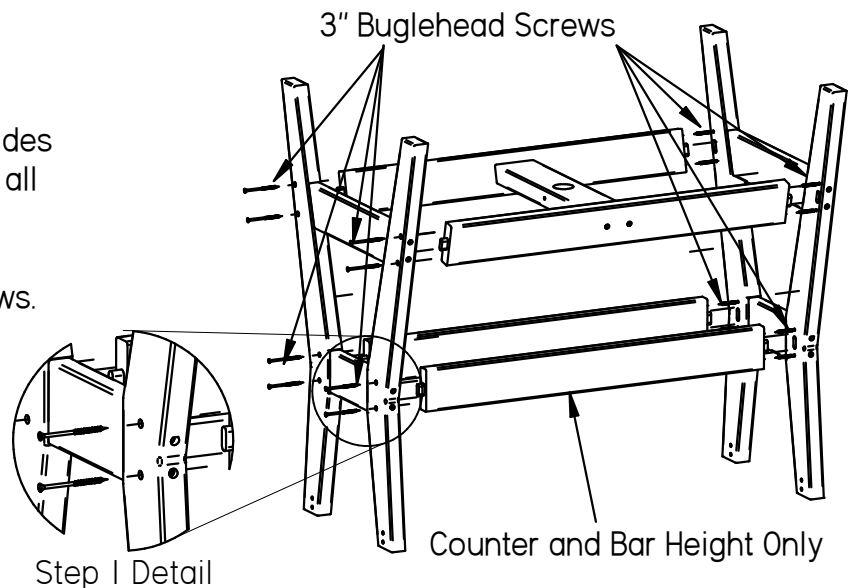

Step 2

Start by placing the center leg over the umbrella plug as shown and fasten leg frame to bottom of table top using 8-5/8" Panhead Screws. *Note: Do not over tighten screws!*

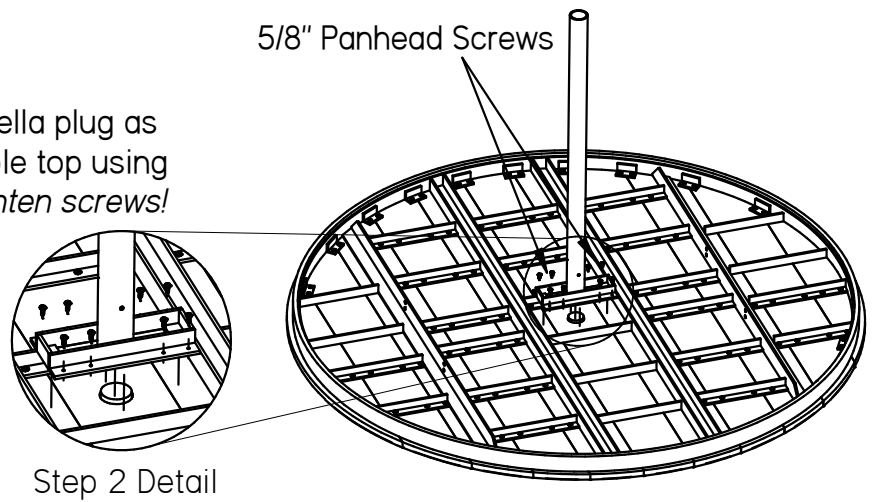

Step 3

Lift base assembly over the center leg and onto the bottom of the table top. Line up holes in base ends with holes in the aluminum frame on the table top and attach base to frame using 1/4"x2" Bolts and 1/4" Flange Nuts. *Note: Ensure bolts and nuts are properly secured using a wrench and supplied Allen Wrench.*

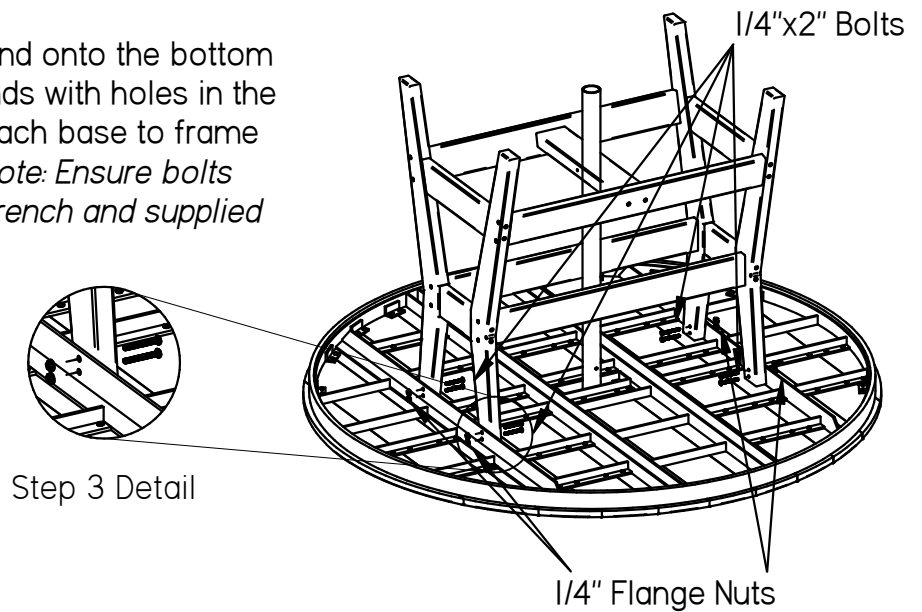

Step 4

Start by placing a table brace against the bottom of the table top and against the inside of a base leg as shown. Fasten the brace against the leg using 1, 1-1/2" Buglehead Screw. Next fasten the aluminum piece against the top using 2, 5/8" Panhead Screws. *Note: The aluminum piece that is fastened against the brace should be placed against the table top.*

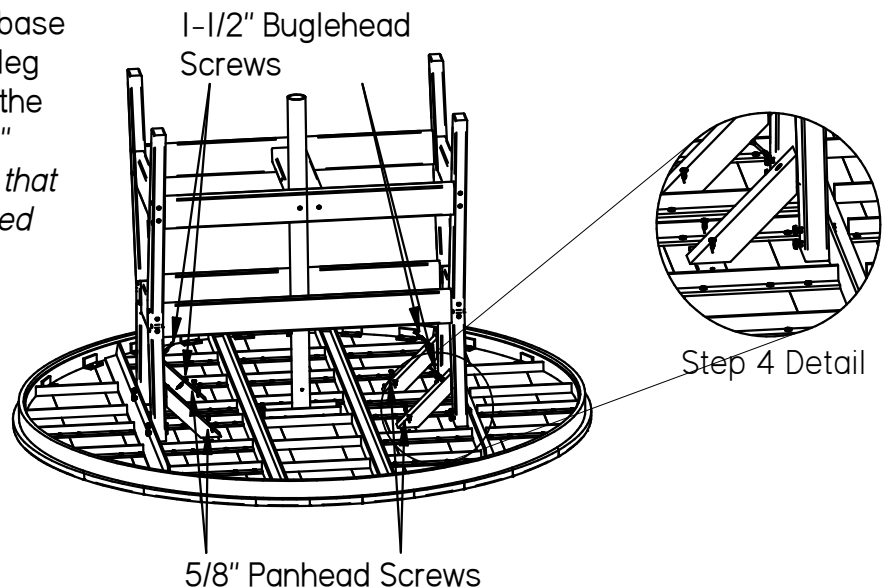

When tightening screws or lags, **DO NOT OVERTIGHTEN** to avoid stripping their hold on the material!