

Read this instruction carefully. See hardware and furniture part list for guidance. Be sure all parts are complete, before you assemble. Place all wooden furniture parts on a clean and flat soft surface to prevent from being scratched. Follow the figure to start assembling.

CAUTIONS : 1. Do not FULLY - TIGHTEN the nut or nut bolt until all nut or bolt is ready assembled.
 2. Do not OVER - TIGHTEN the nut or bolt to avoid causing damages to the thread.
 3. Keep all hardware parts out of reach of children.

NOTE : THE LIST AND QUANTITY SHOWN ARE FOR 1 UNIT ASSEMBLY.
 Tool needed : Screwdriver (not provider).

PART LIST		
ITEM	DESCRIPTION	QTY
A	HEADBOARD	1 PC
B	HEADBOARD LEG (L/R)	2 PCS
C	HEADBOARD SUPPORT WOOD	2 PCS
D	HEADBOARD SUPPORT RAIL	1 PC
E	BED LEG	4 PCS
F	FOOTBOARD	1 PC
G	SIDE RAIL	2 PCS
H	CENTER RAIL	1 PC
I	CENTER SUPPORT LEG	3 PCS
J	CENTER SUPPORT WOOD	2 PCS
K	BED SLAT	26 PCS

HARDWARE LIST		
ITEM	DESCRIPTION	QTY
1	JCBB BOLT M8 x 50mm	10 PCS
2	WOOD SCREW M3.5 x 16mm	8 PCS
3	WOOD SCREW M4 x 20mm	2 PCS
4	M8 SPRING WASHER	10 PCS
5	M8 FLAT WASHER	10 PCS
6	BED SLAT SIDE FITTER	26 PCS
7	BED SLAT CENTER FITTER	13 PCS
8	M5 ALLEN KEY (BALL SHAPE)	1 PC

STEP 1

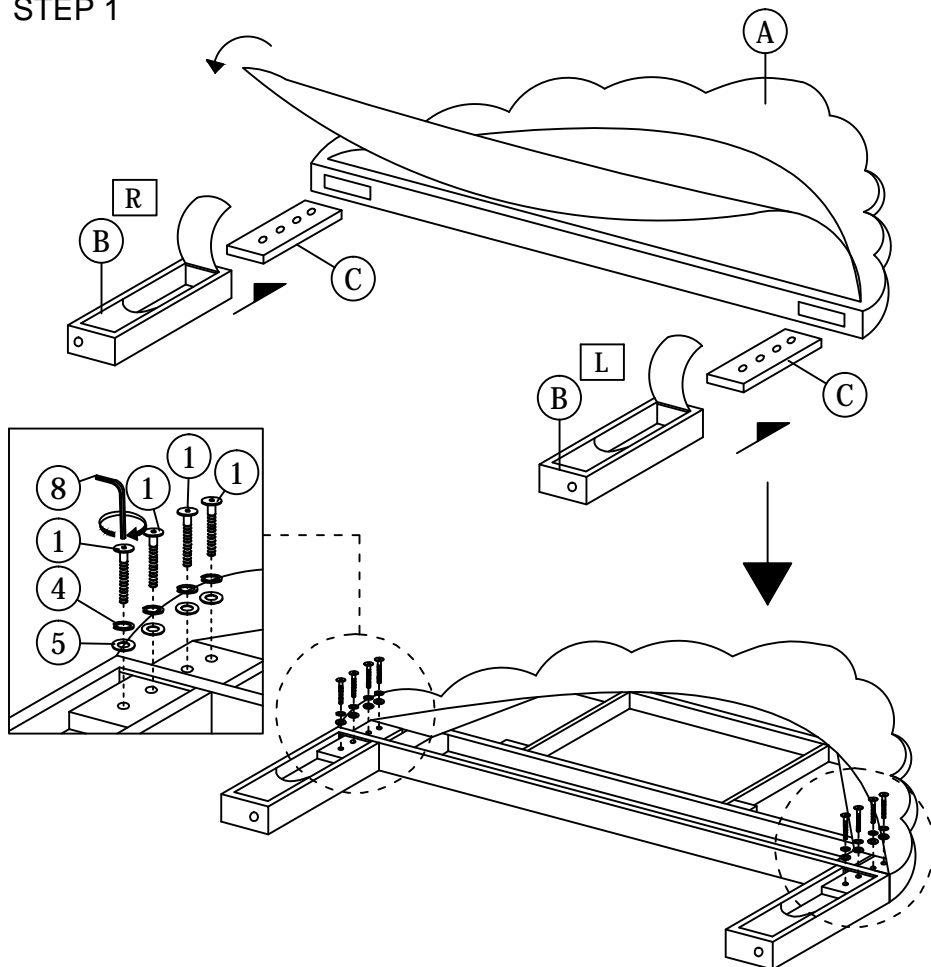

STEP 2

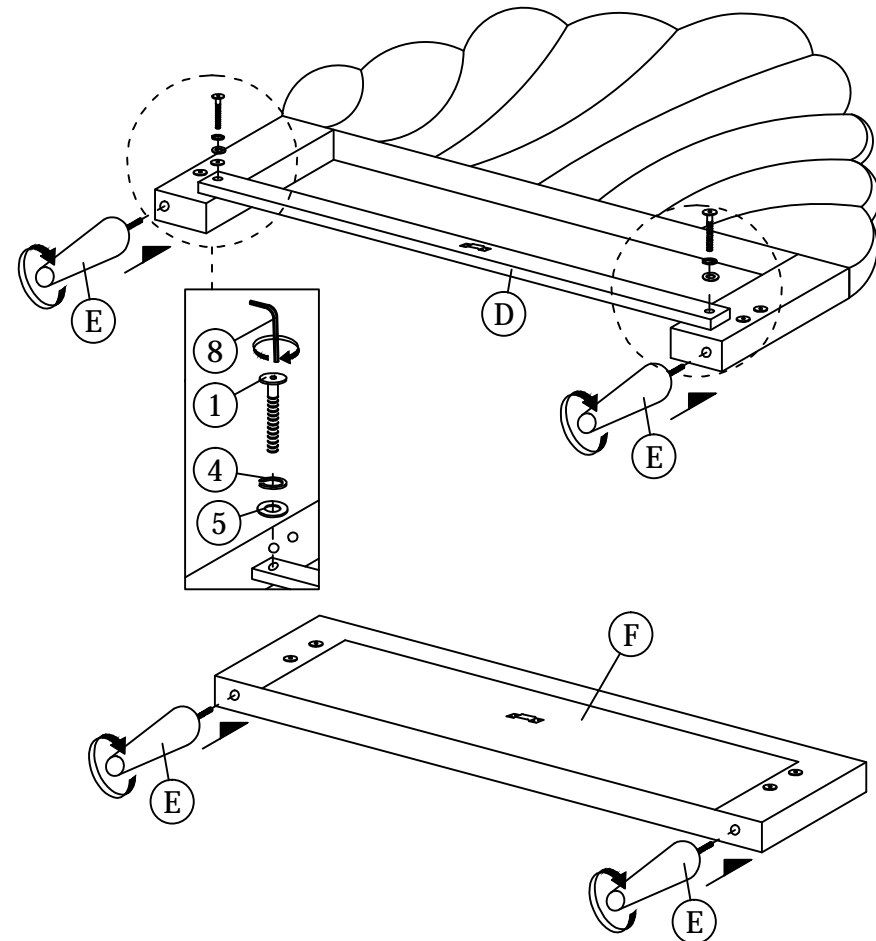

ASSEMBLY INSTRUCTIONS

STEP 3

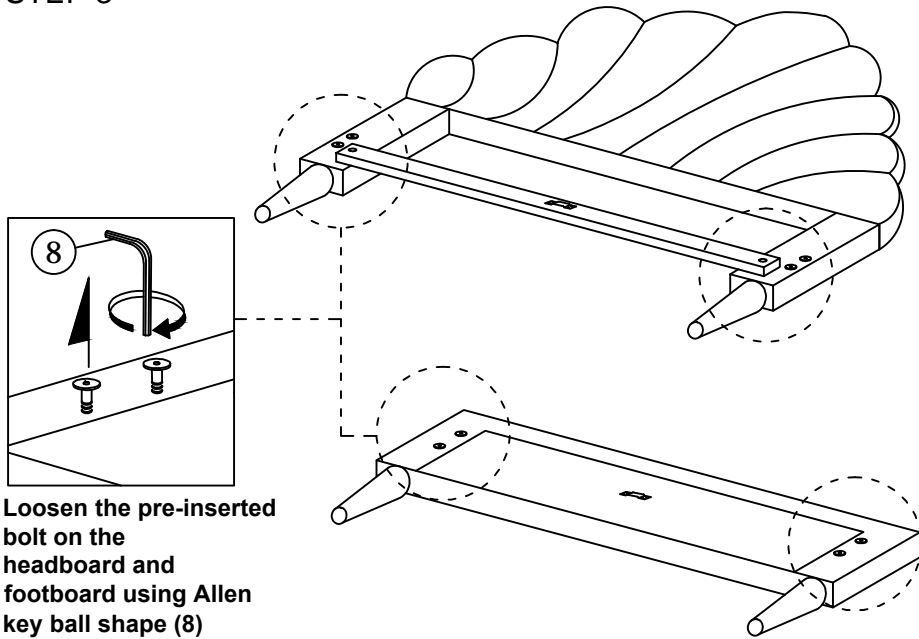

STEP 4

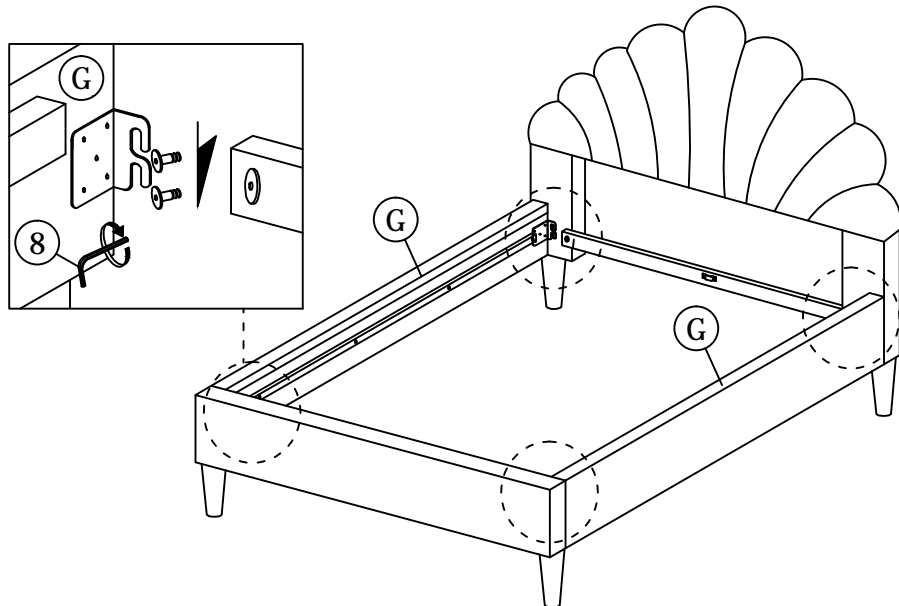

STEP 5

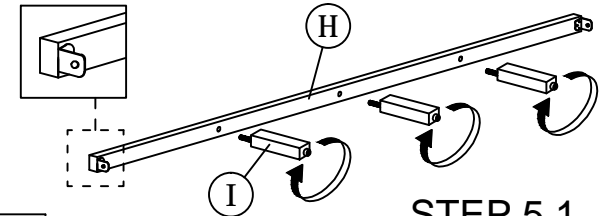

STEP 5.2

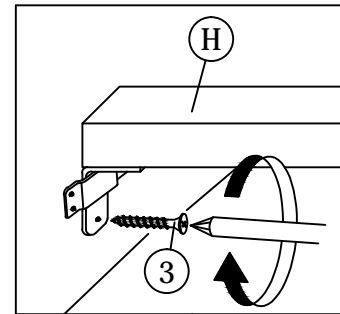

STEP 5.1

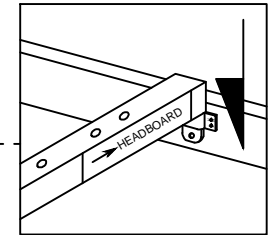

Note: Make sure the sticker " \rightarrow HEADBOARD" faced to headboard [A]

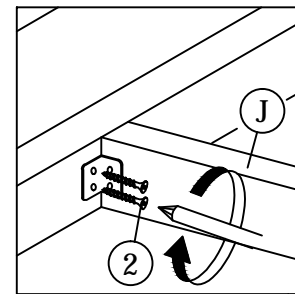

STEP 5.3

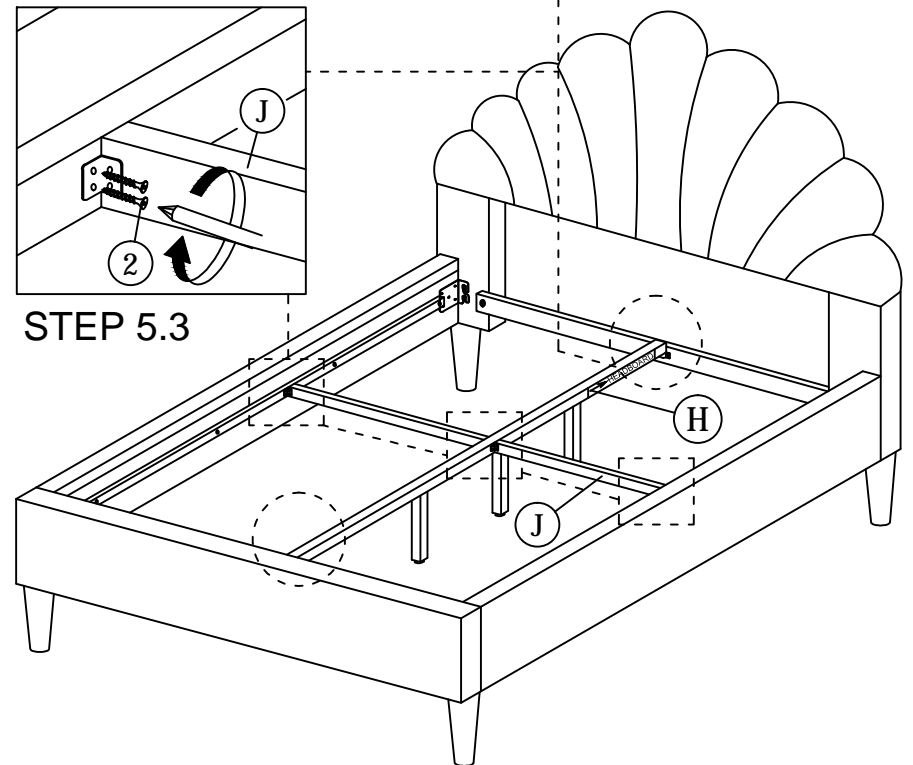

ASSEMBLY INSTRUCTIONS

STEP 6

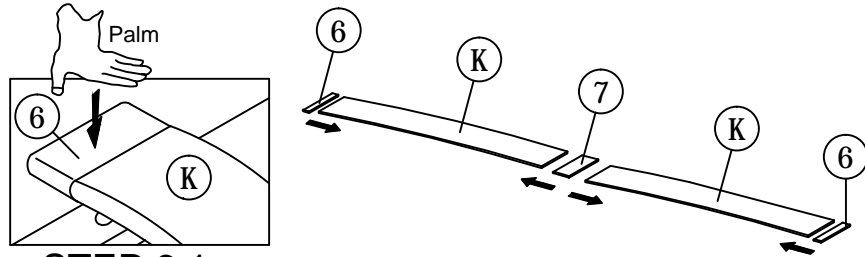

STEP 6.1

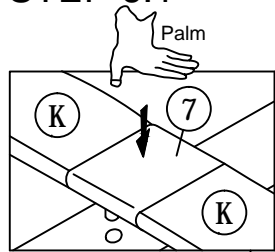

STEP 6.2

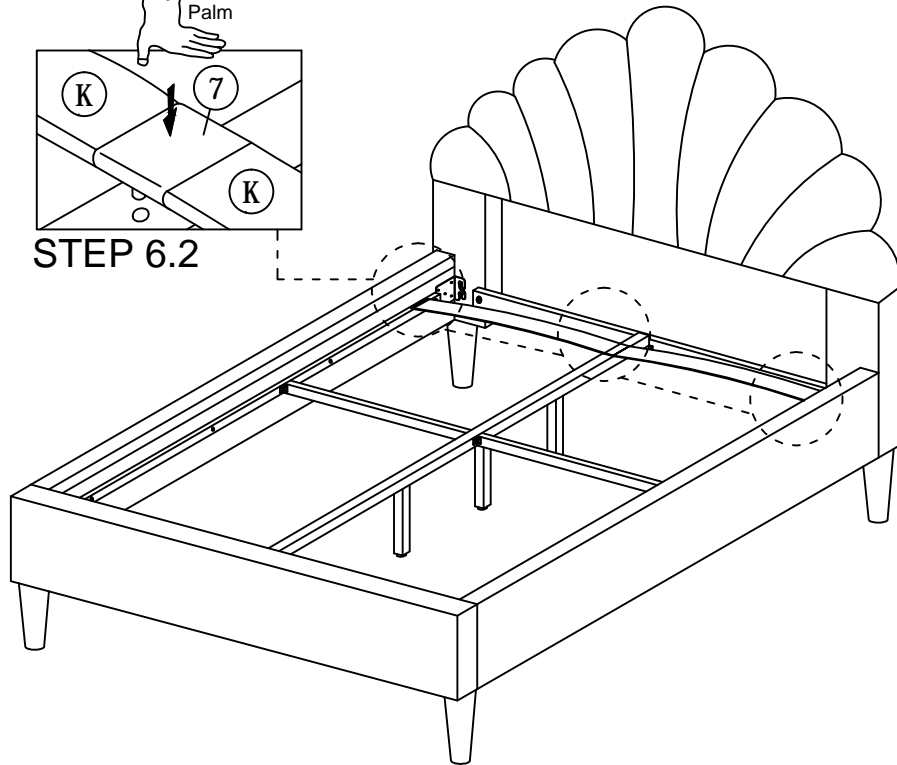

STEP 7

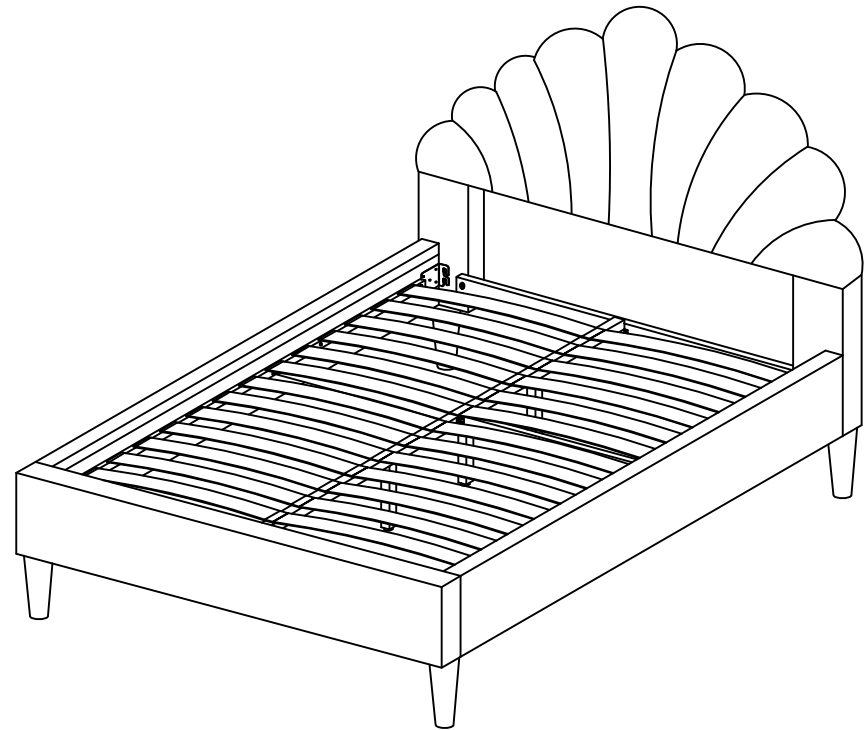

*** When moving the bed position, the center support legs must be adjust to be straight to avoid any broken problem.**