

A1		LEFT ARM	1
A2		RIGHT ARM	1
B		BACK	1
C		SEAT	1
D		U-SHAPE FITTING	1
E		BASE	1
F		SPRING WASHER - M6	4
G		WASHER - M6	26
H		NUT - M6	8
I		BOLT - M6 X 15mm	4
J		BOLT - M6 X 35mm	10
K		HEX WRENCH	1
L		WRENCH	1
M		PLASTIC CAP 1	12
N		PLASTIC CAP 2	8
O		Seat Cushion	1
P		Back Cushion	1
Q		Bolt - M6 X 40mm	4

PRE-ASSEMBLY PREPARATION:

--- Please read through the instructions before beginning assembly.

--- Clear out the space for assembly and lay out all of the parts based on the Parts List, extra room will allow you to easily determine if all the pieces are present.

--- Keep small parts and pieces away from children until fully assembled.

Step 1: Guide build-in nuts on back panel (B) into the holes on left arm (A1) and right arm (A2). Attach left arm (A1) and right arm (A2) to back panel (B) with 4pcs bolts (I) and 4pcs washers (G).

* Do not fully tighten bolts until the entire frame is assembled.

* Notice the position of left arm (A1) and right arm (A2), swapped arms would cause assembly failure. (Side wall of arm should towards inside)

The armrests and backrest are horizontal !

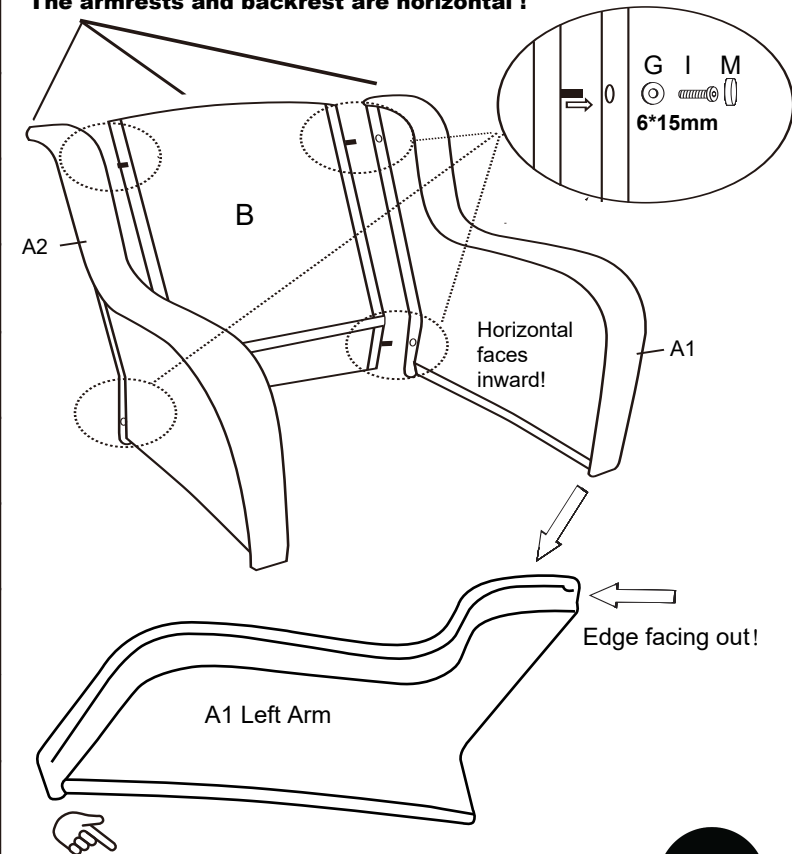

If the hole position is not aligned, please try to exchange the two armrests.



Step 2: Place seat panel (C) between arms and back panel, attach it to arms (A1 and A2) with 4pcs bolts (J) and 4pcs washers (G), and then attach it to back panel with 2pcs bolts (J) and 2pcs washers (G).

* Due to design and handicraft limitation, it may has around 1/2 in. gap between arms and back panel after assembly. This is normal and will not affect outlooking and daily usage.

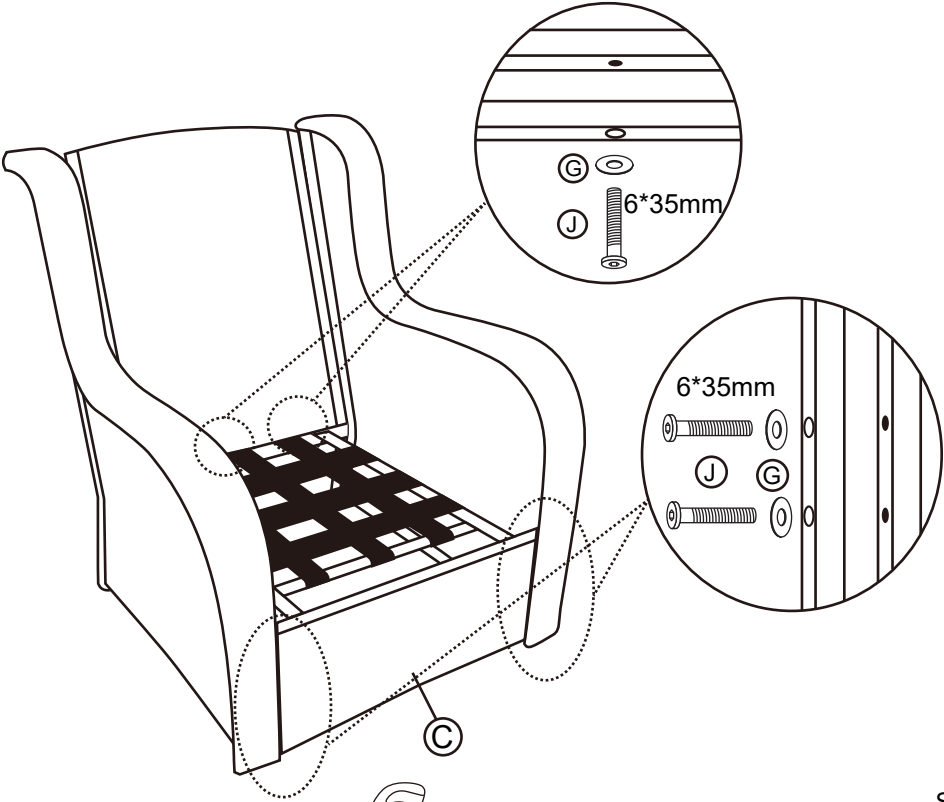

Step 3: Put U-shape fitting (D) onto base (E) with holes aligned, attach with 4pcs bolts (J), 8pcs washers (G), 4pcs spring washers (F), 4pcs nuts (H) and 4pcs plastic cap(N). Put 4pcs plastic cap (M) on the base where shown as below drawing.

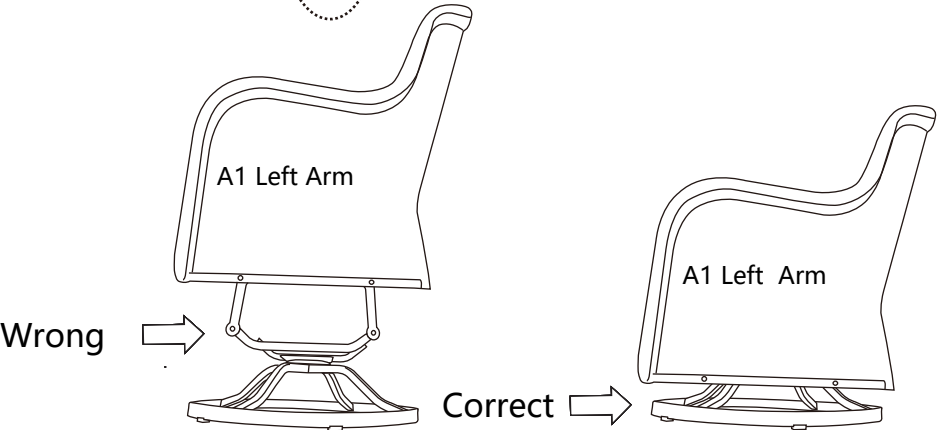
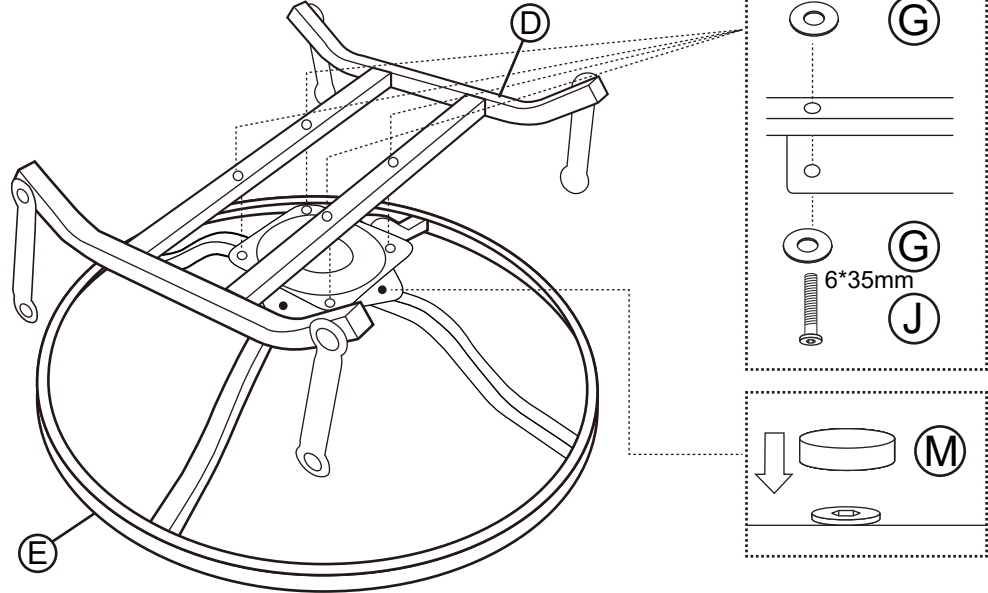

Step 4: Tip chair over with one side on the ground. Attach U-shape fitting to arms with 4pcs bolts (Q), 4pcs nuts (H) and 4pcs plastic cap(N,M). Verify the alignment and adjust, now fully tighten all the bolts using Hex Wrench (K) and Wrench (L) Put seat cushion and back pillows on.

