

ASSEMBLY INSTRUCTIONS

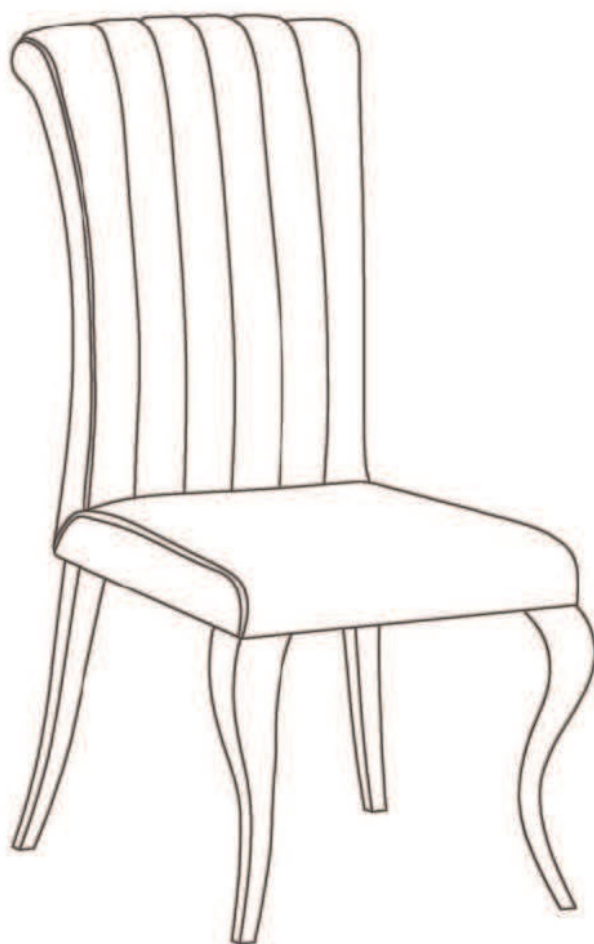

ASSEMBLY INSTRUCTIONS

ASSEMBLY TIPS:

1. Remove hardware from box and sort by size.
2. Please check to see that all hardware and parts are present prior to start of assembly.
3. Please follow attached instructions in the same sequence as numbered to assure fast & easy assembly.



WARNING!

1. Don't attempt to repair or modify parts that are broken or defective. Please contact the store immediately.
2. This product is for home use only and not intended for commercial establishments.



ASSEMBLY TIME

5 MINUTES

PARTS IDENTIFICATION

B1(BOX 1)

A SEAT AND BACK



1PC

B2(BOX 2)

B BASE



1PC

Z

HARDWARE IDENTIFICATION

1 BOLTS M6*25

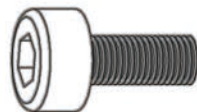

4PCS

2 FLAT WASHER Ø6*16



4PCS

3 ALLEN WRENCH 4MM



1PC

NOTE:

Quantities shown are for one chair.

Hardware pack is located

ASSEMBLY INSTRUCTIONS

STEP 1

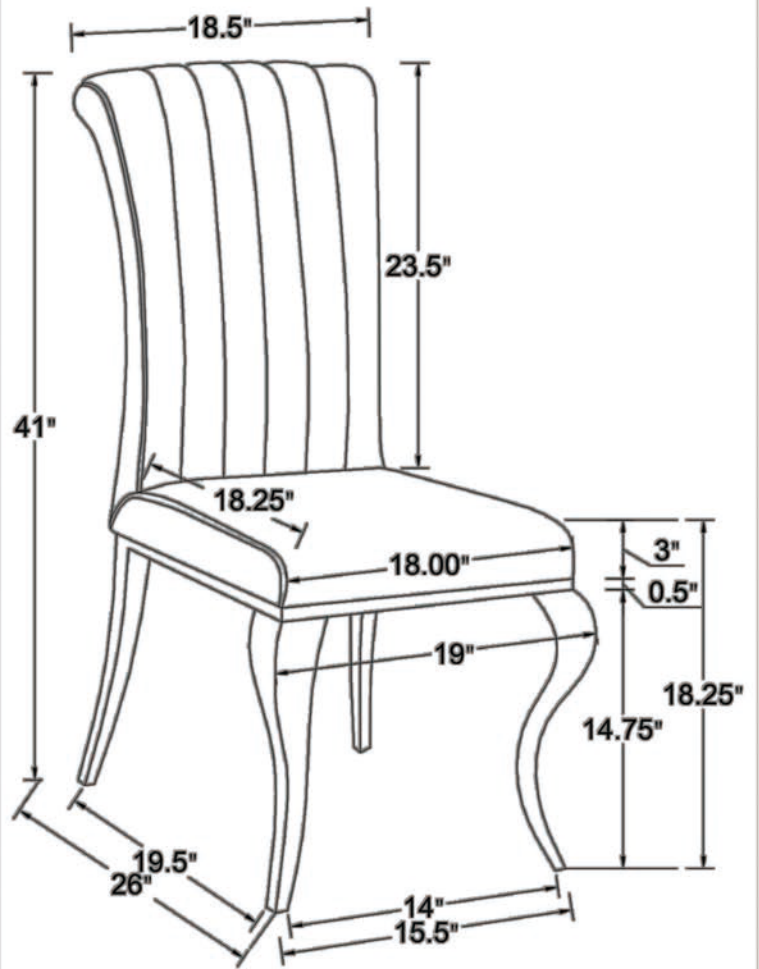
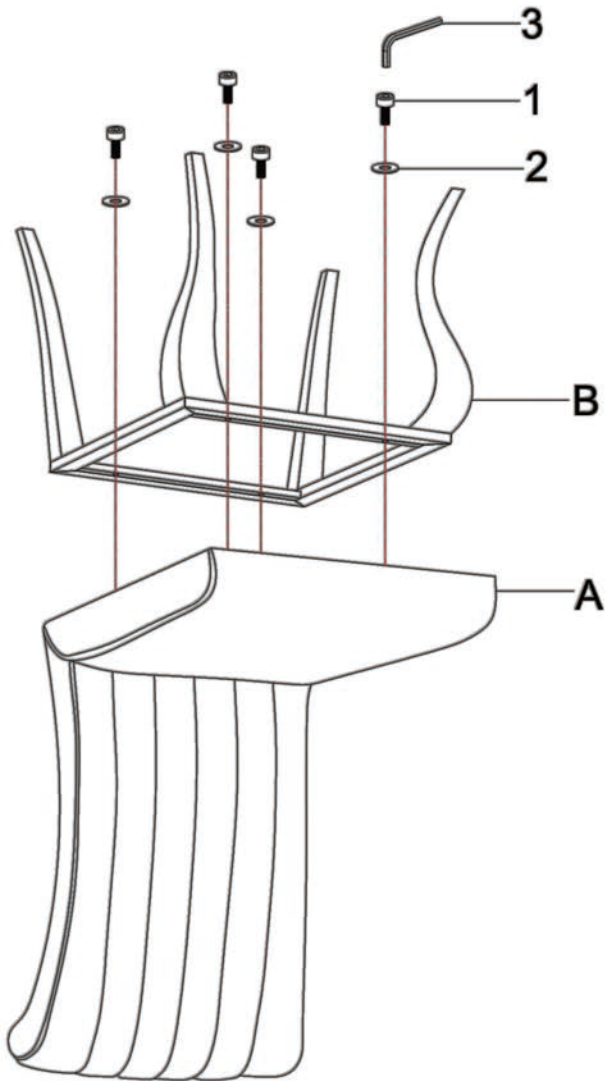

NOTE :DIMENSION TOLERANCE $\pm 5\%$