

TABLE

Assembly Instructions

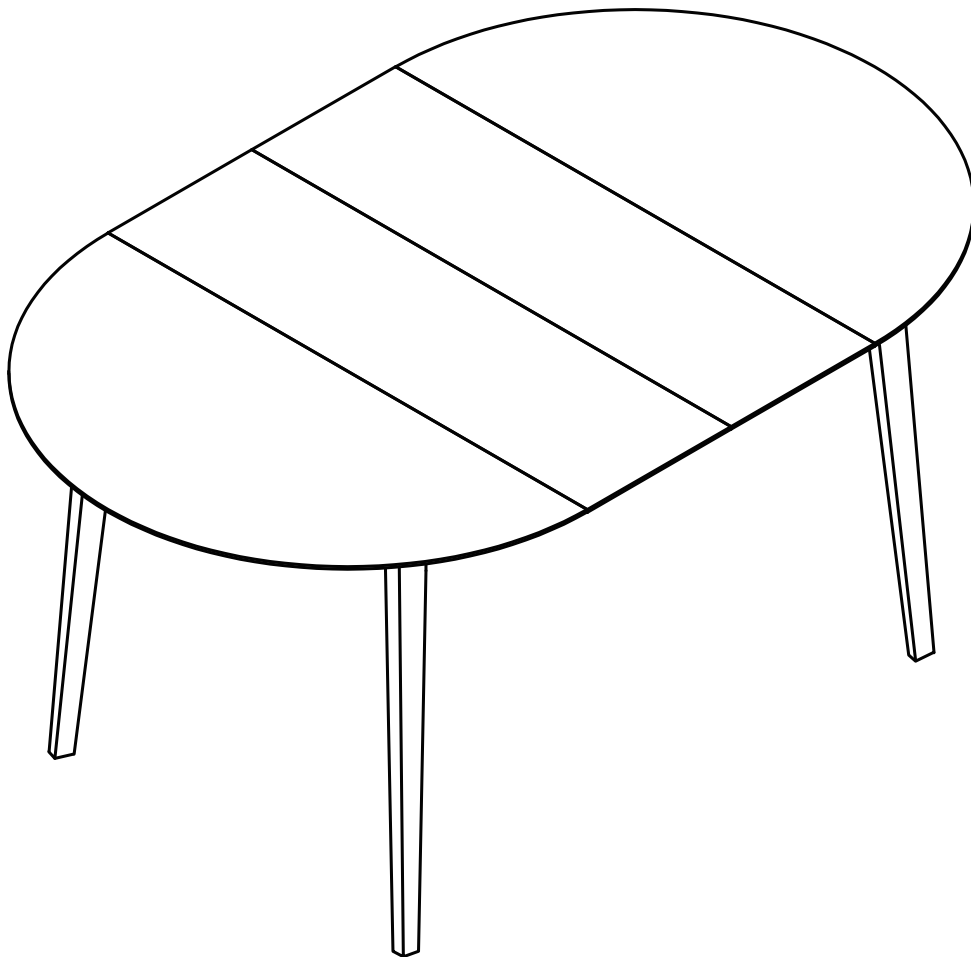

General Assembly Guidelines

- I. Ensure that all parts and hardware are available before beginning assembly.
- II. Follow each step carefully to ensure the proper assembly of this product.
- III. Two people are recommended for ease in the assembly of this product.
- IV. If there are accessories missing or any other problems, please contact the seller first.
- V. Power tools should not be used to assemble this product.

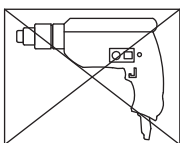

- VI. A Phillips head screwdriver is required for the assembly of this product (not included).

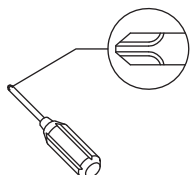

Parts List

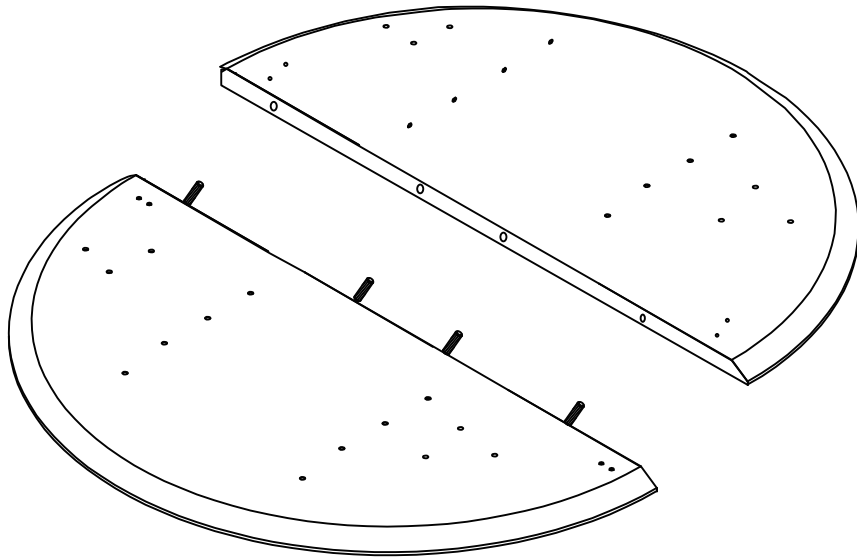

Board ①x2

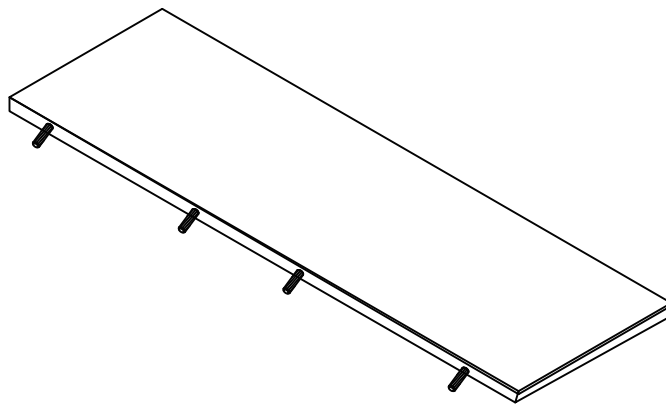



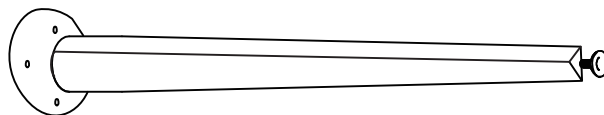



Board ②x2

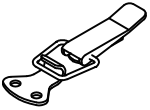
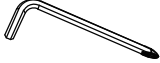

Leg ③x4

Hardware List

A		Bolt	28	pcs
B		Screw	24	pcs
C		Shim	28	pcs
D		Spring washer	28	pcs
E		Pull button	6	pcs
F		Hex Key	1	pcs
G		Skidway	2	pcs

*The hardware quantities listed above are required for proper assembly.
Some extra hardware may also have been included.*

Step 1

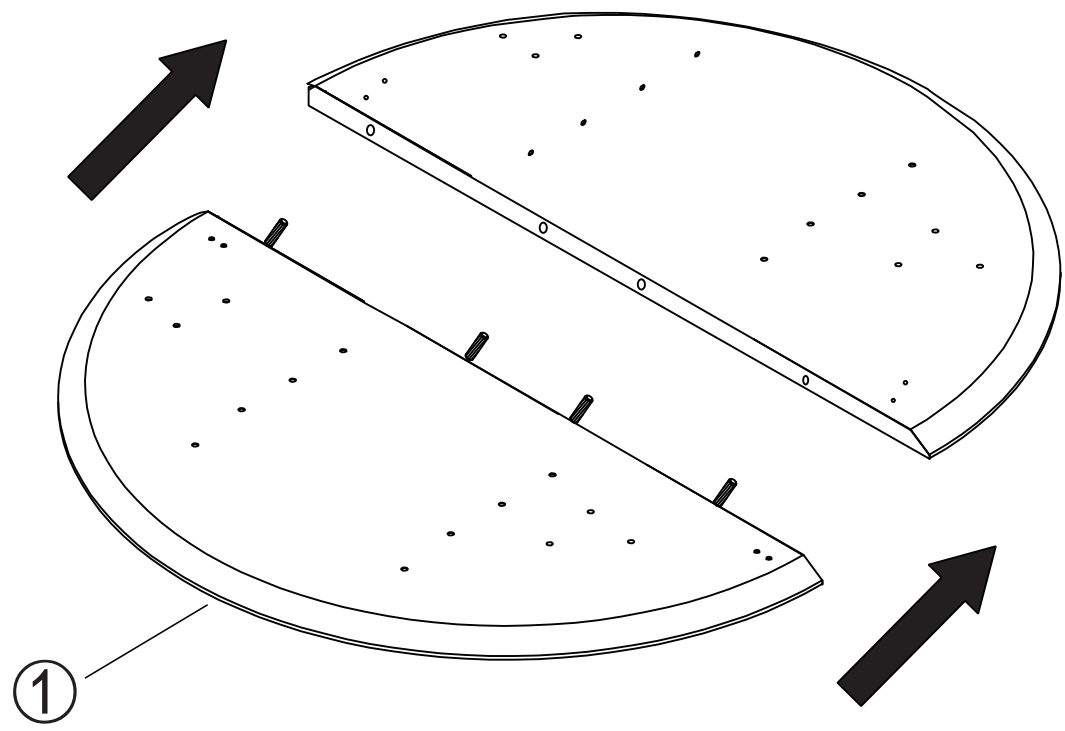
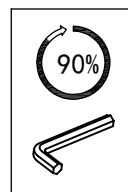

Step 2

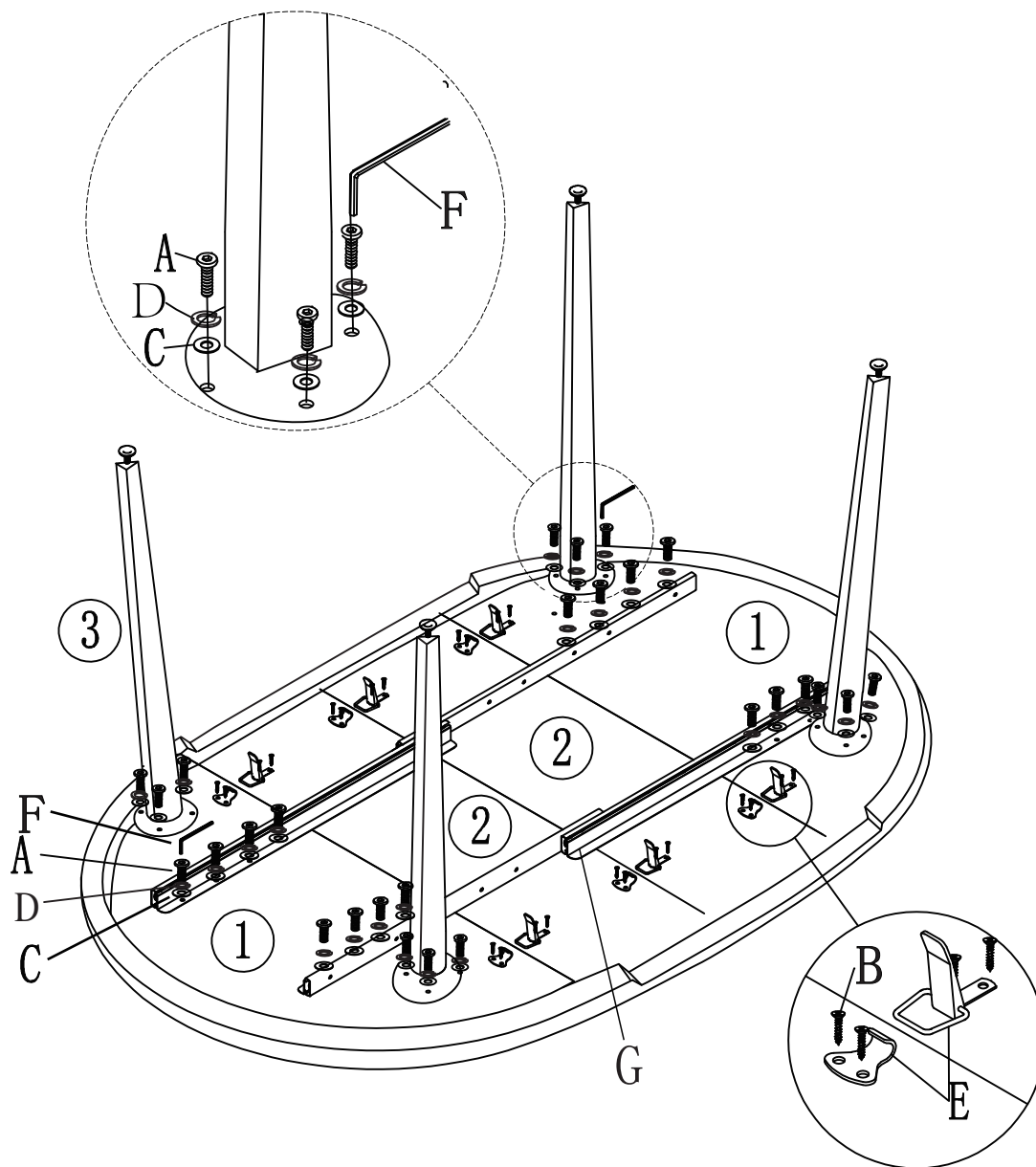
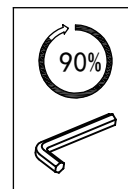

Install the skidways first, then the legs, and finally the pull buttons

Step 3

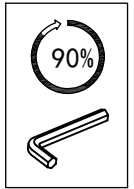

Lock it before flip the table

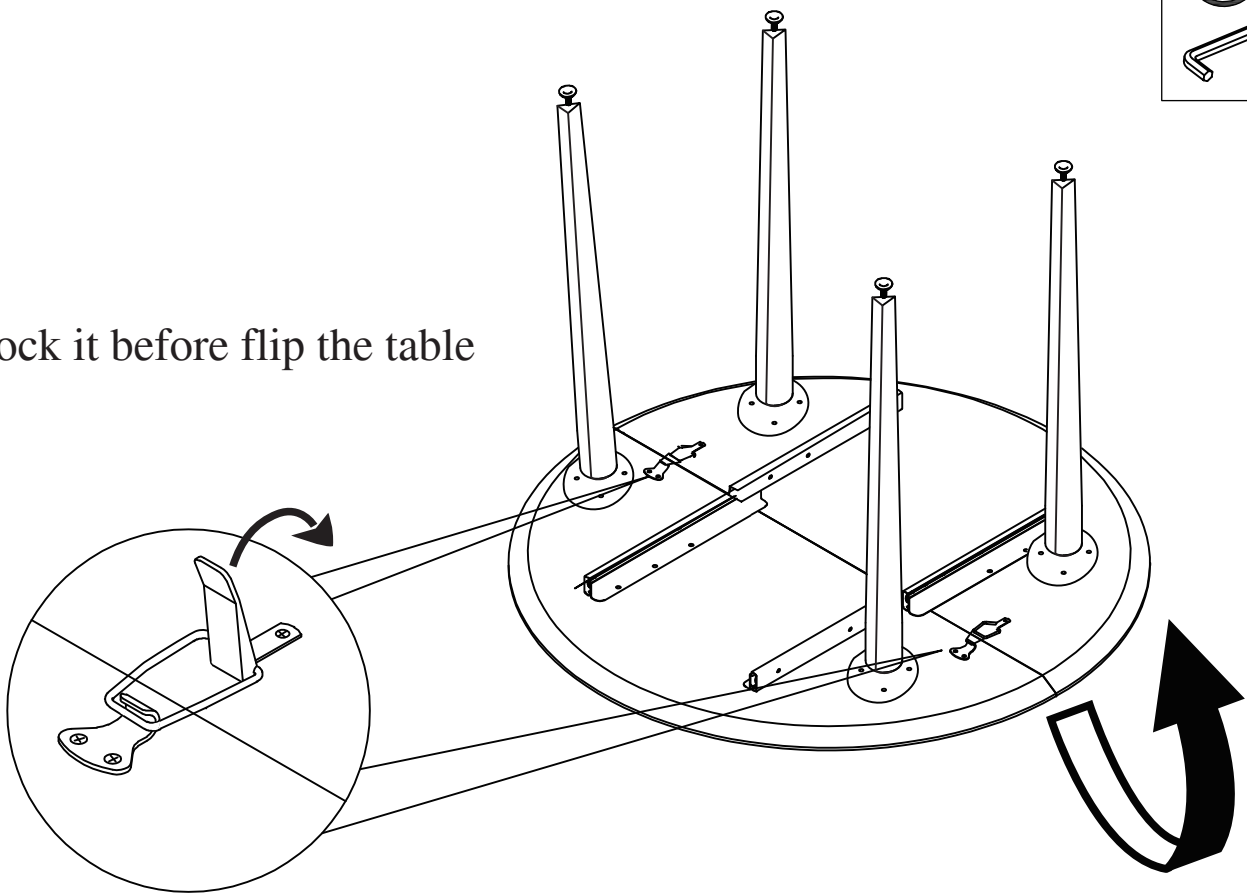

Notice: Hold on to the top of the table when it's flipped, don't hold legs

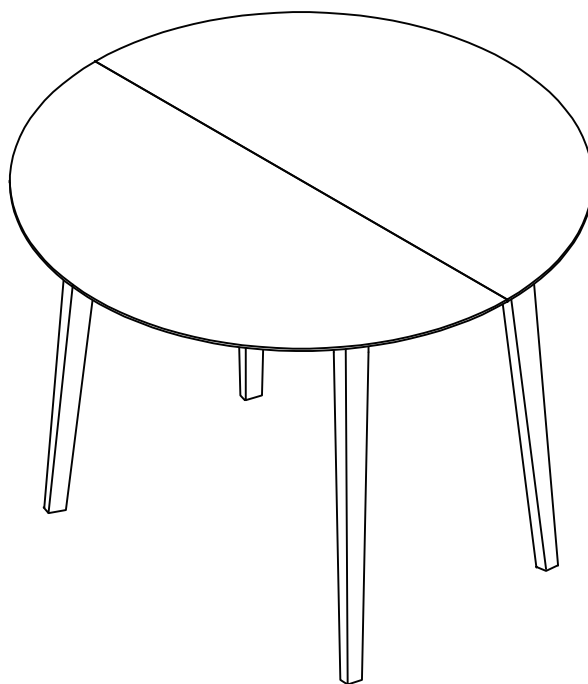

Step 4

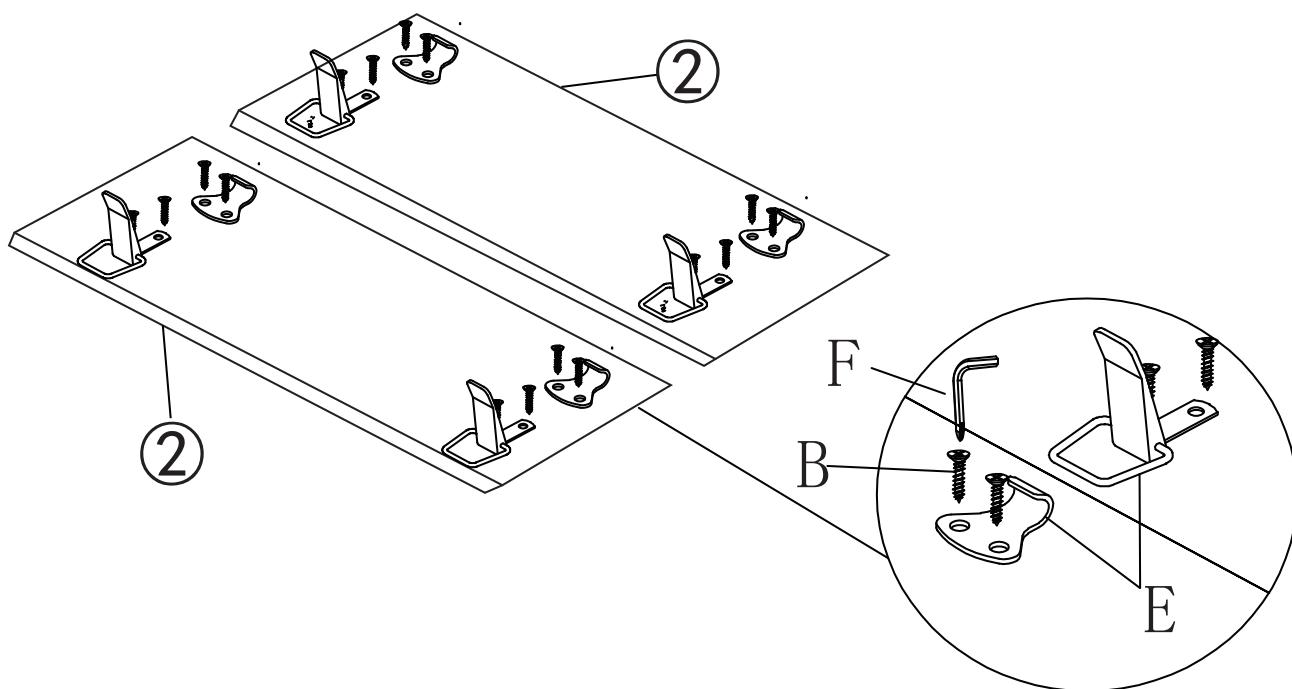
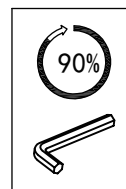

Step 5

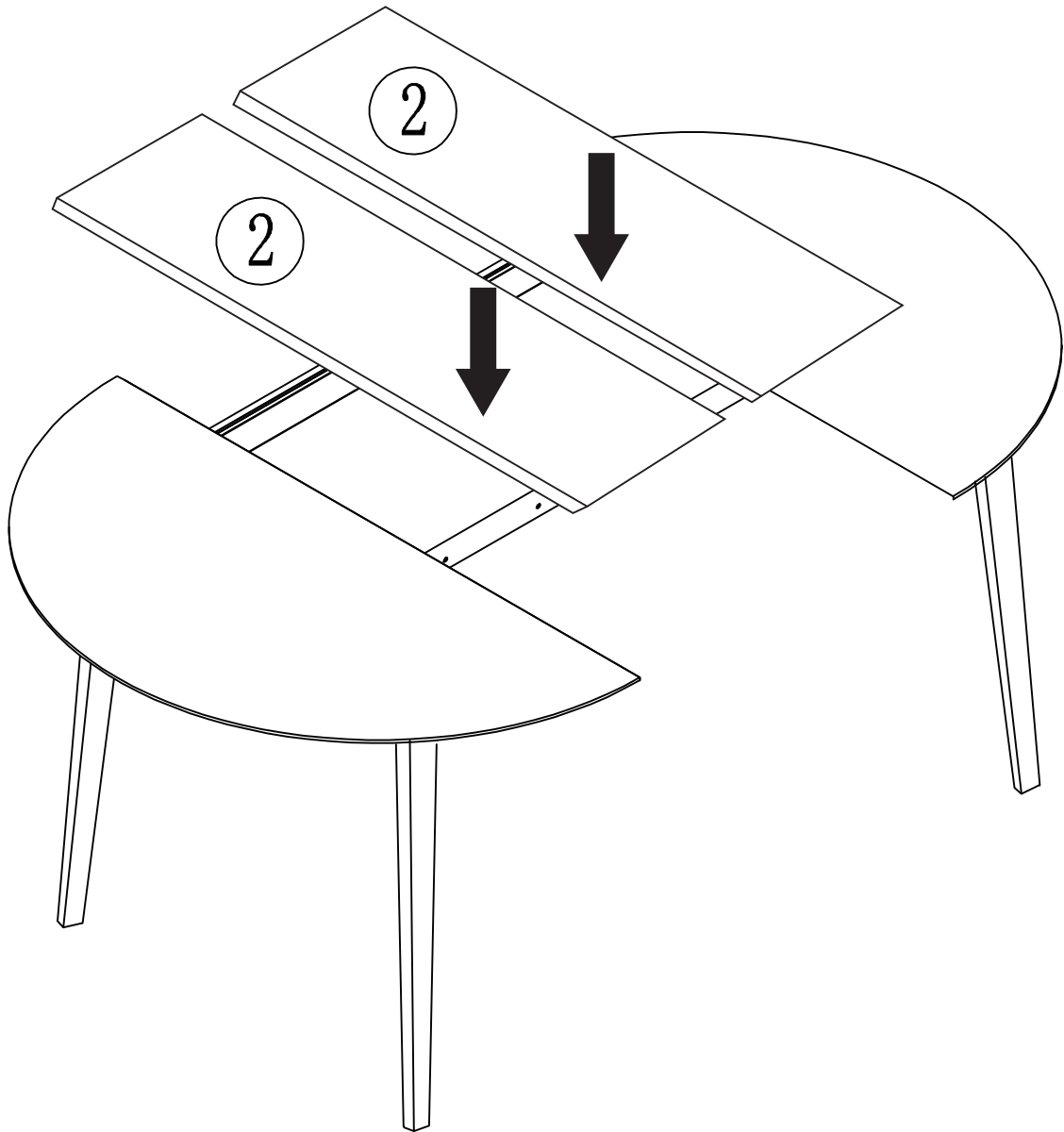

Step 6

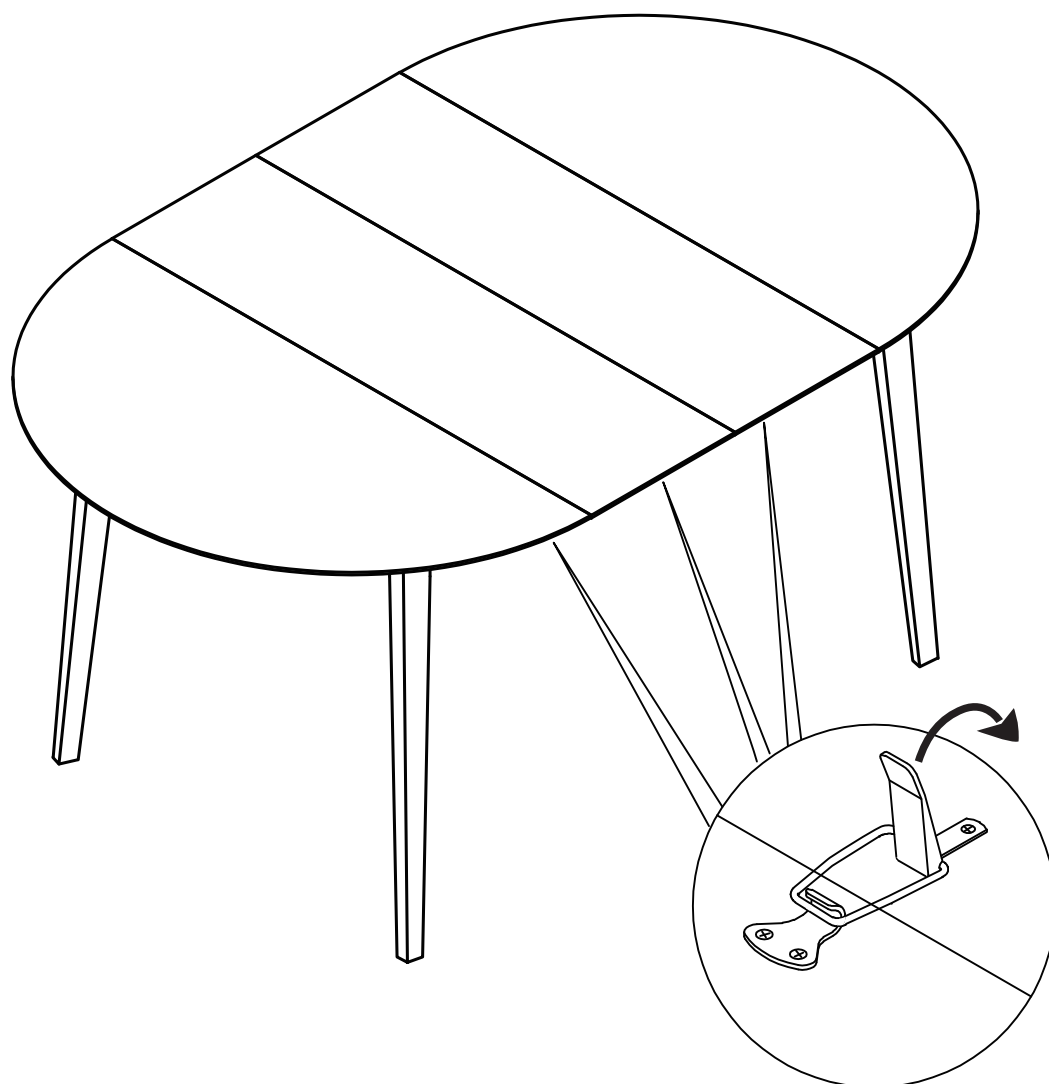

Lock all pull buttons before to use the table

Final Assembly