

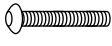

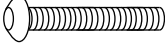



INSTRUCTION MANUAL

FITTINGS

- A.  M6x40 *11 B.  M8x50 *5 C.  * 5
- D.  * 5 E.  * 5 F.  * 1 G.  * 1

ASSEMBLY ICON

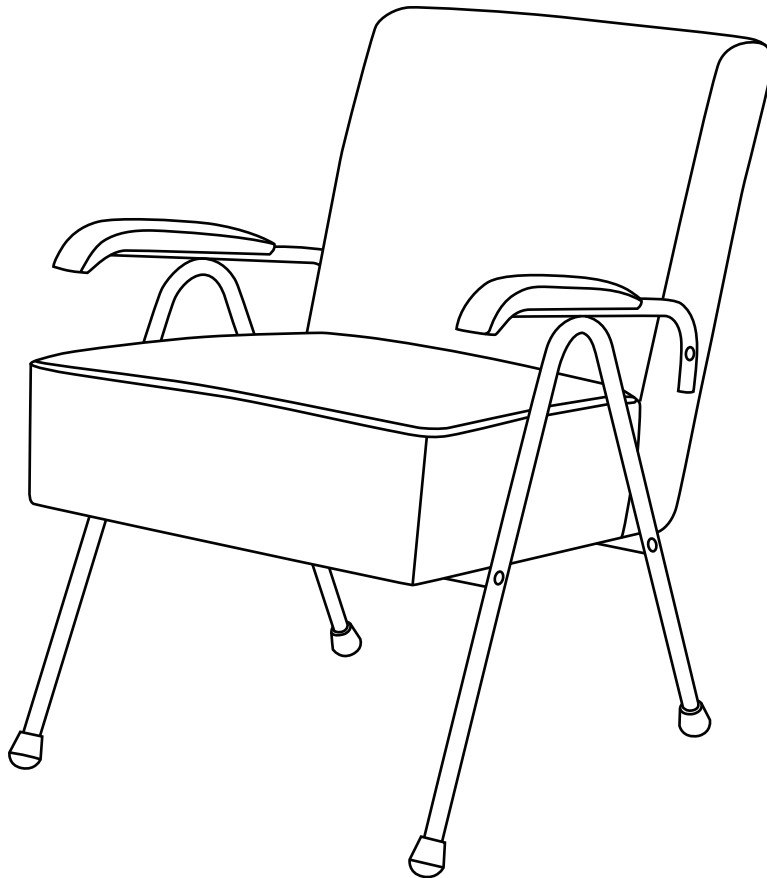

Tighten the product as shown in the figure above.

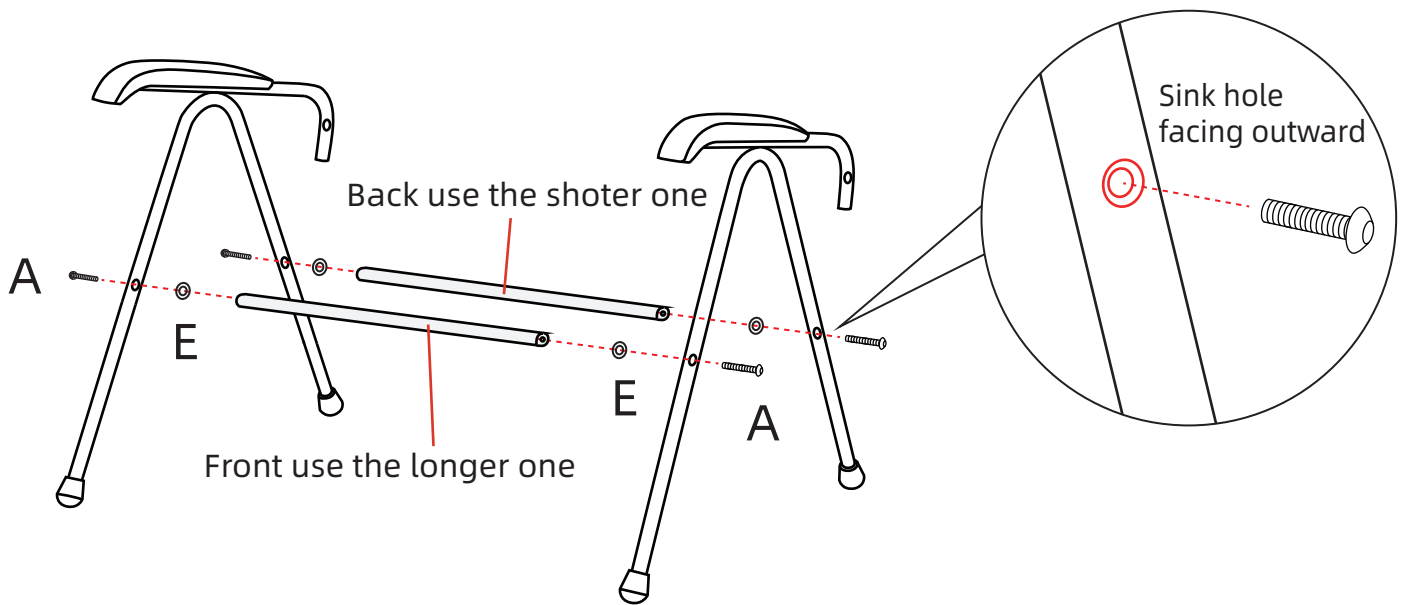

1、 Install the iron frame together with screws A as shown in the diagram.
 (E acts as a buffer and does not affect structural stability if not installed)
 Pay attention to installing the long iron rod in the front and the armrest iron frame with the countersunk hole facing outward

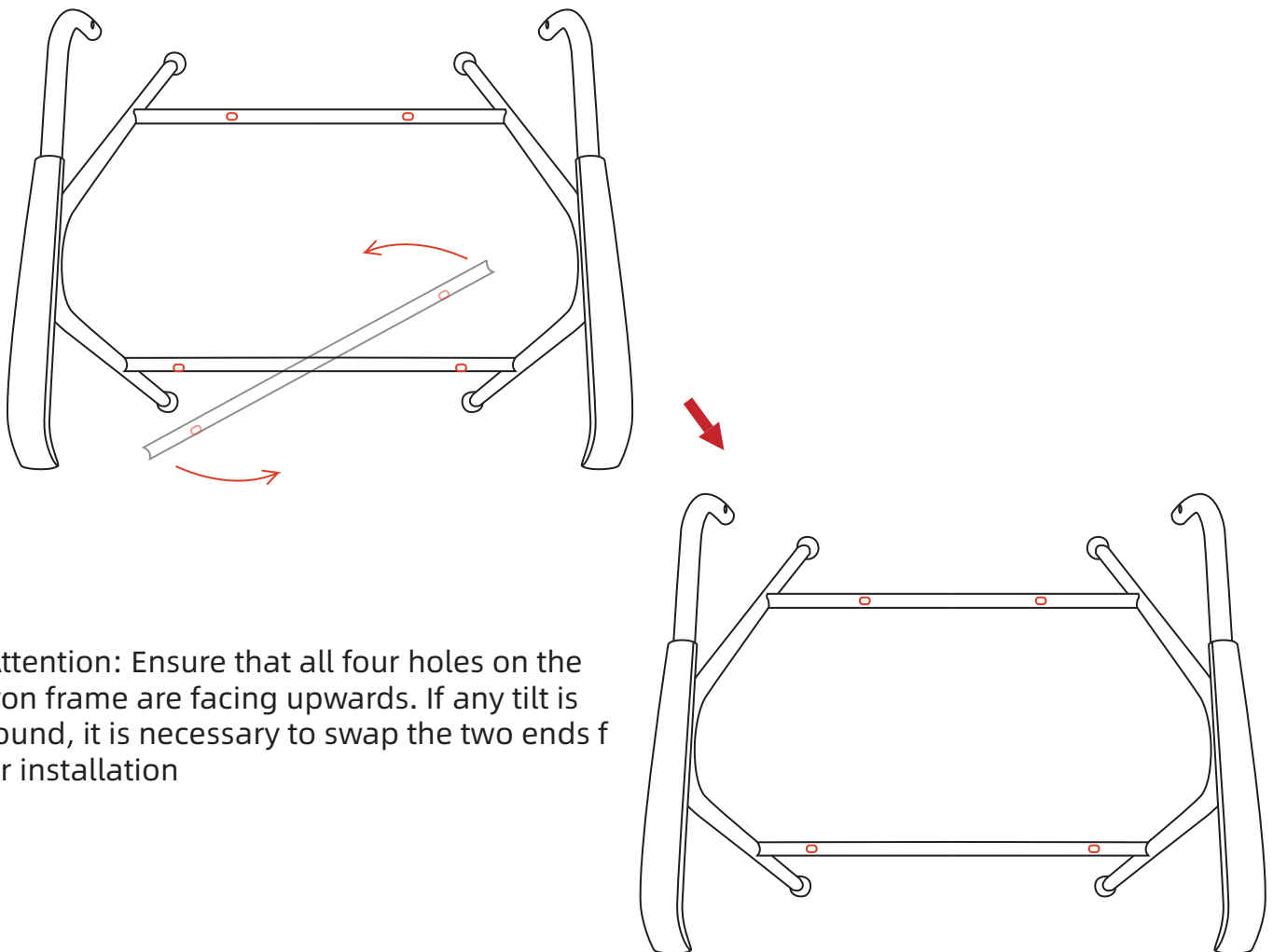

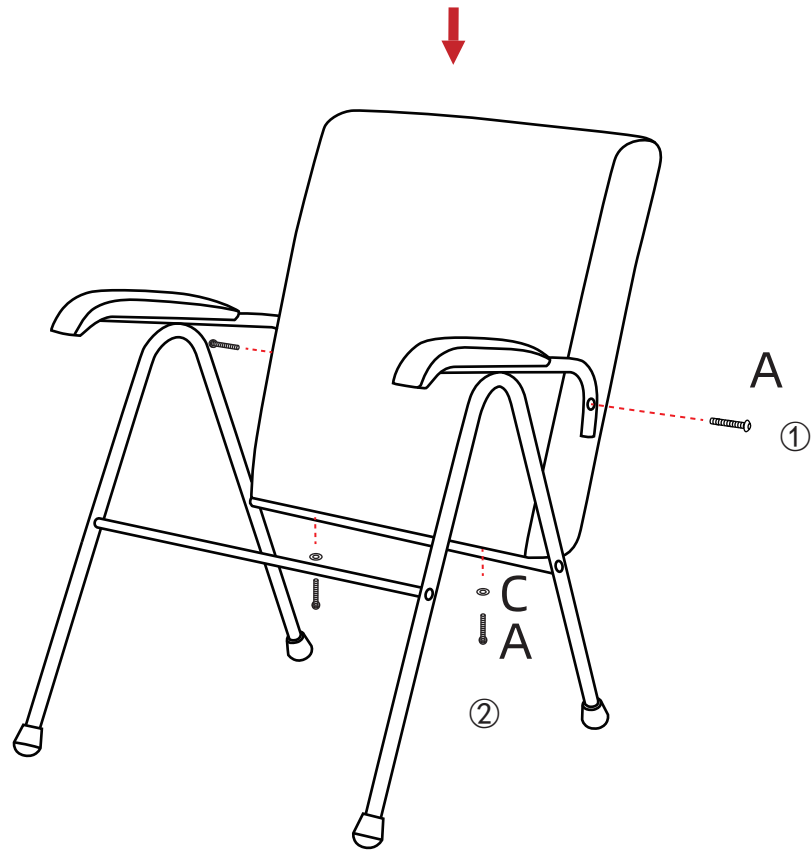

2、 Place the backrest on the back of the iron frame, first use screw A to install the armrest position ①, then use screw A to install the seat cushion position ② with washer C

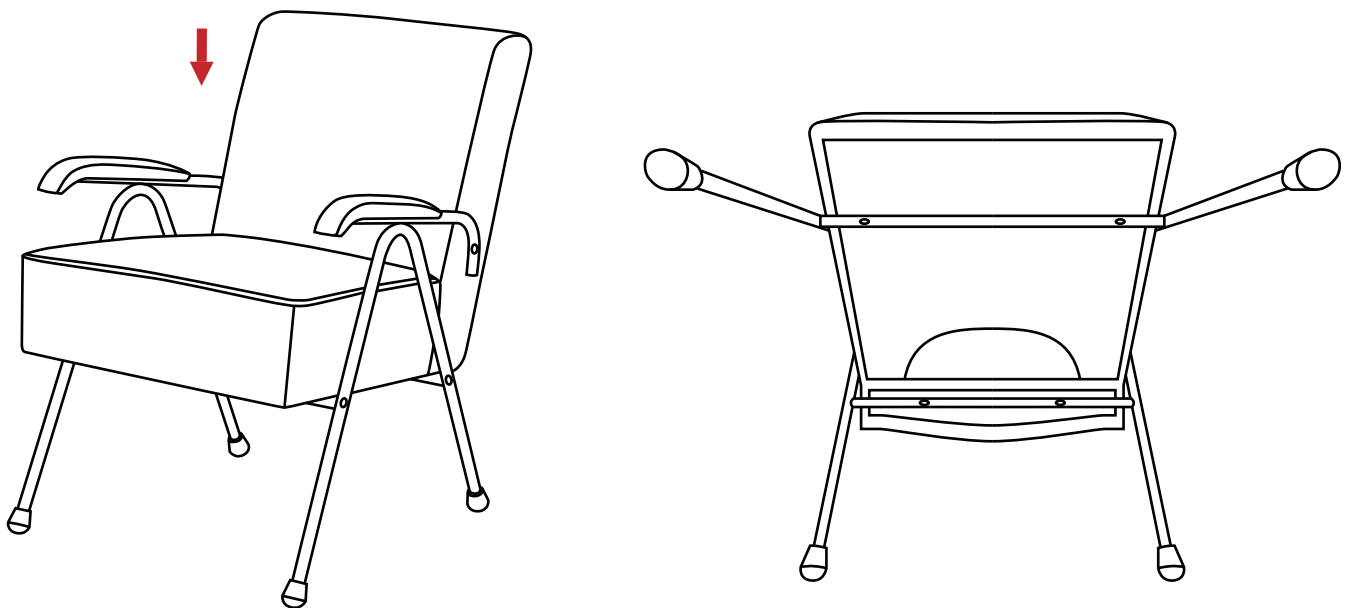

3、 Put on the seat cushion and then flip it backwards

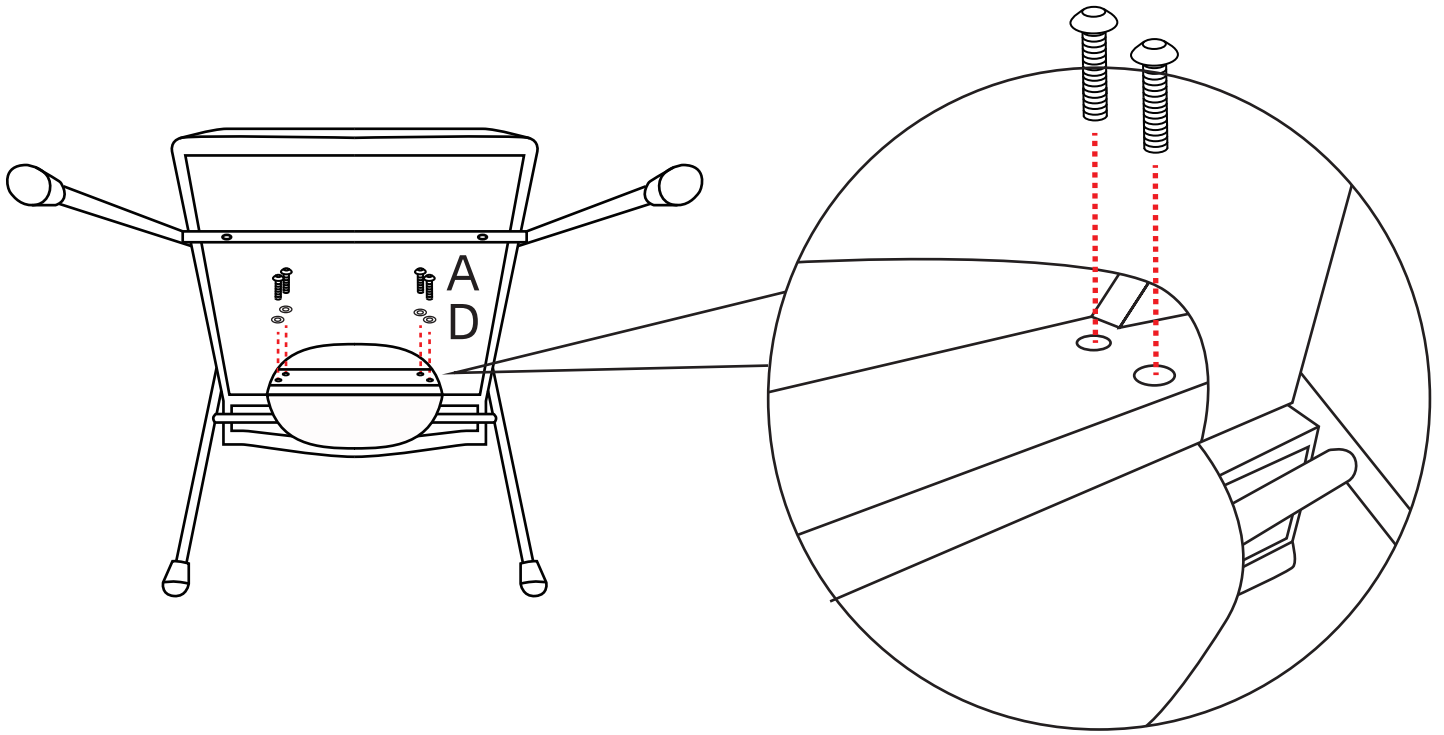

4、 Open the zipper at the bottom of the seat cushion, use B screws to fit D washers, and install the seat cushion on the backrest

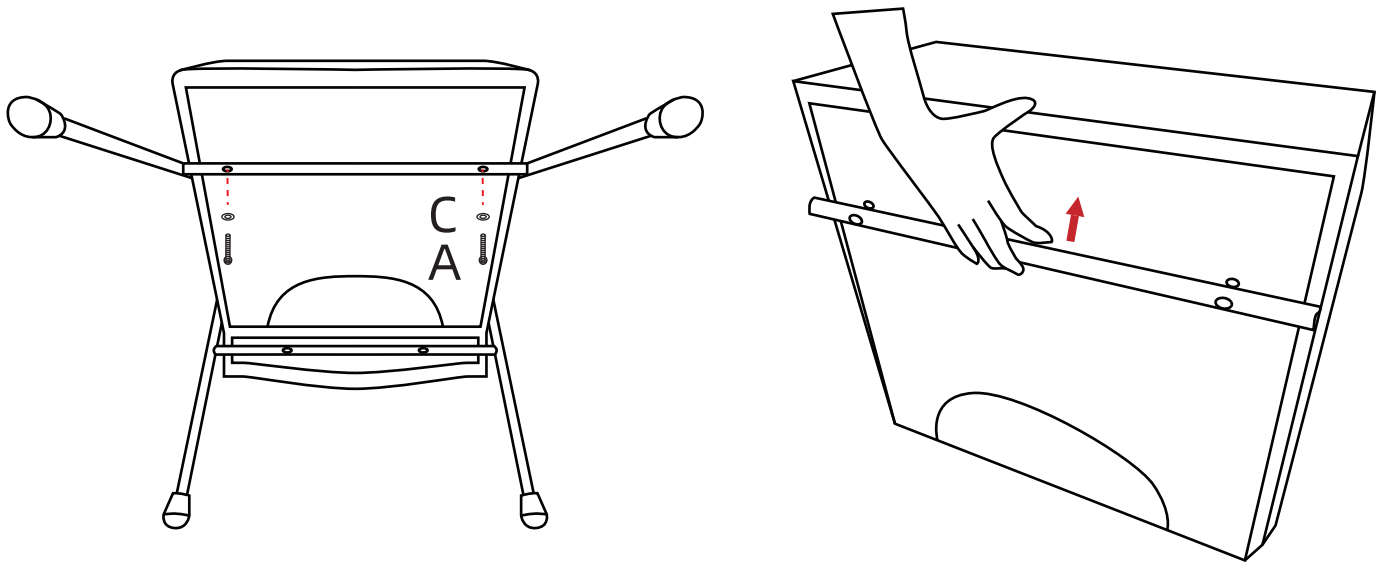

5、 Pull up the zipper, then use the A screw to cover the C gasket, and install the seat cushion onto the iron frame

Tip: If there is a deviation in the hole position between the seat cushion and the iron frame during installation, you can move the iron frame to align with the hole position for installation