

**ASSEMBLY INSTRUCTIONS**

**UPHOLSTERED BED**

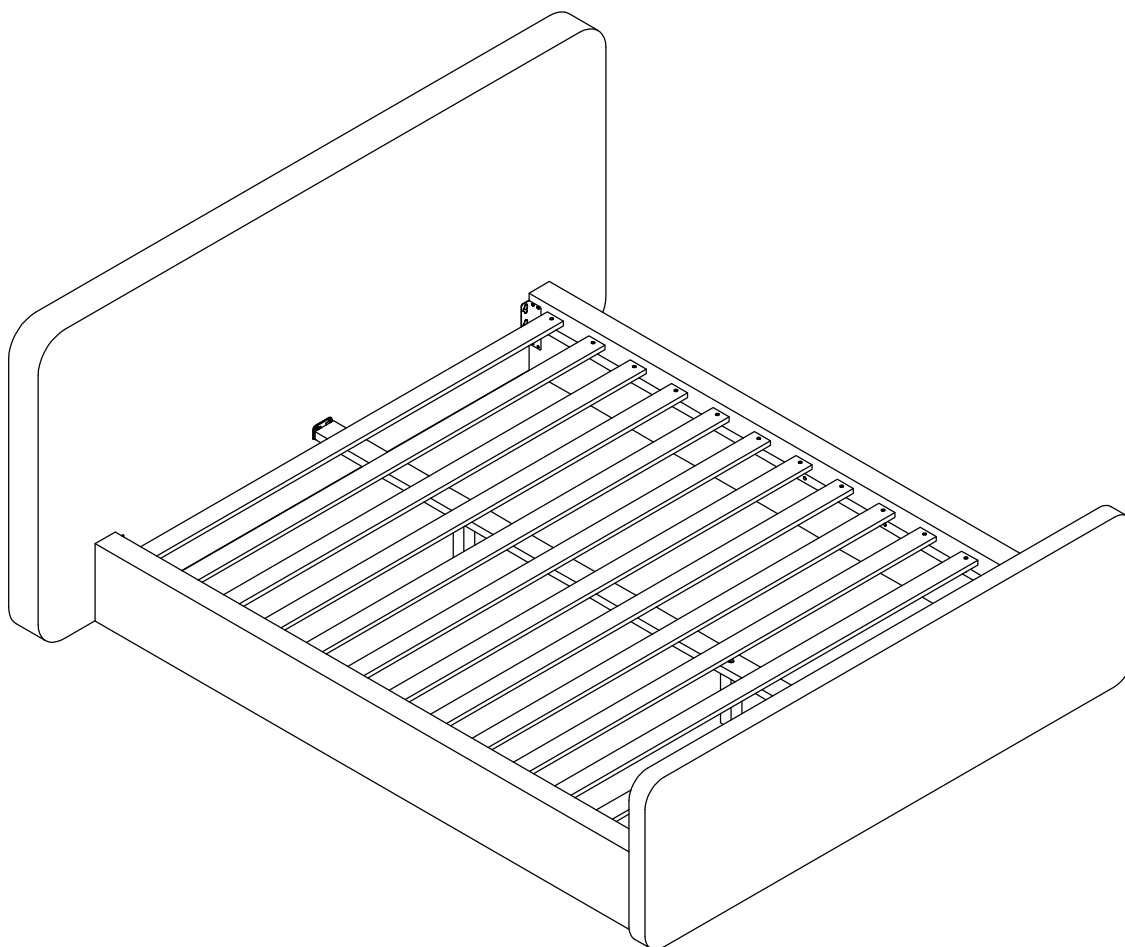

# UPHOLSTERED BED

## ASSEMBLY INSTRUCTIONS

Please kindly read these instructions carefully and keep for future reference. Refer to parts inventory for guidance, and ensure you have all pieces before starting.

When assembling, place all parts on a soft, clean, and flat surface such as a carpet to prevent scratches.

If you're having difficulty, our friendly Customer Care team is always here to help.

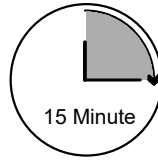





TIME

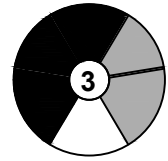



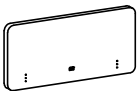

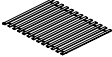

# OF PEOPLE



DIFFICULTY

CODE	PART LIST	Q'TY
①	HEADBOARD 	1 PC
②	SIDE RAIL 	2 PCS
③	FOOTBOARD 	1 PC
④	CENTER SUPPORT 	1 PC
⑤	CENTER LEG 	2 PCS
⑥	SLATS 	1 PC

CODE	HARDWARE LIST	Q'TY
Ⓐ	BOLT M8x30 	12 PCS
Ⓑ	SPRING WASHER 8.5 	12 PCS
Ⓒ	FLAT WASHER 8.5 	12 PCS
Ⓓ	ALLEN KEY 	1 PC
Ⓔ	SCREW M4x25 	26 PCS
SCREW DRIVER (NOT INCLUDED) 		

Note: Make sure you have all the parts and hardware with quantity listed above before assembling the product. A screwdriver is also required (not included)

# UPHOLSTERED BED

## STEP 1

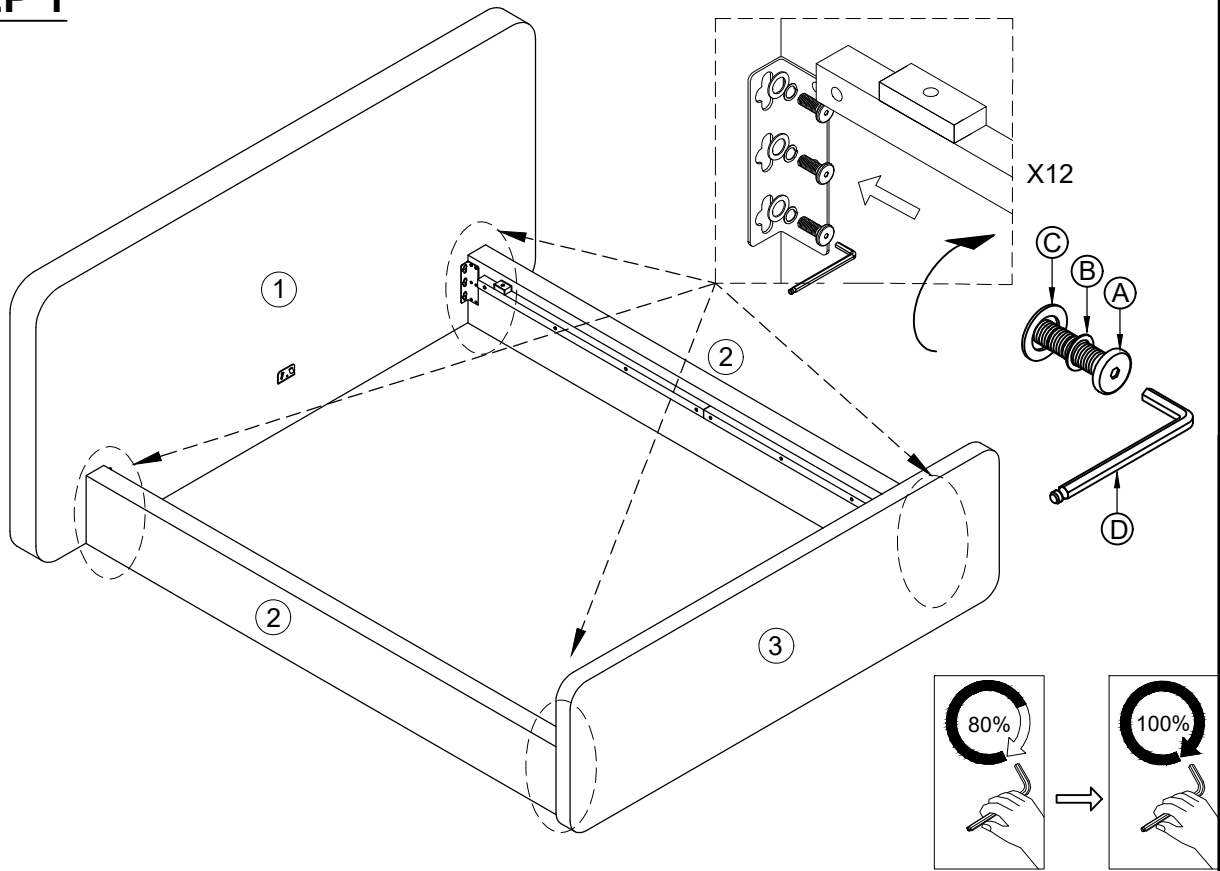

NOTE: FIRST, TIGHTEN ALL BOLTS TO 80% THEN TIGHTEN ALL BOLTS TO 100%  
-PLEASE FOLLOW THE STEPS ABOVE TO AVOID THE ASSEMBLY DIFFICULTY.

## STEP 2

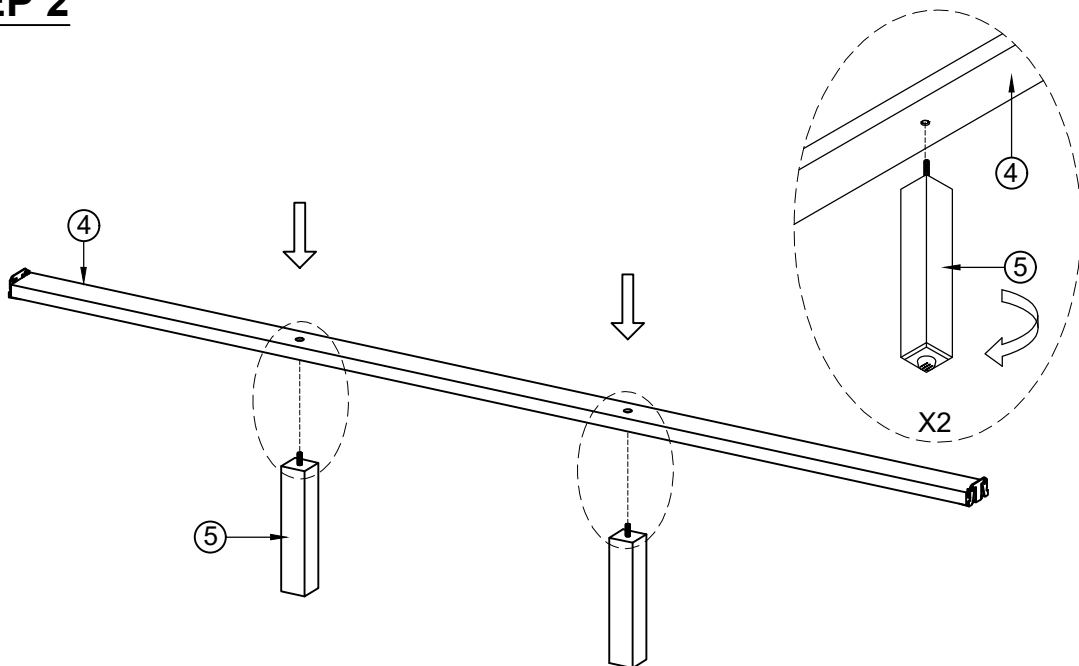

# UPHOLSTERED BED

## STEP 3

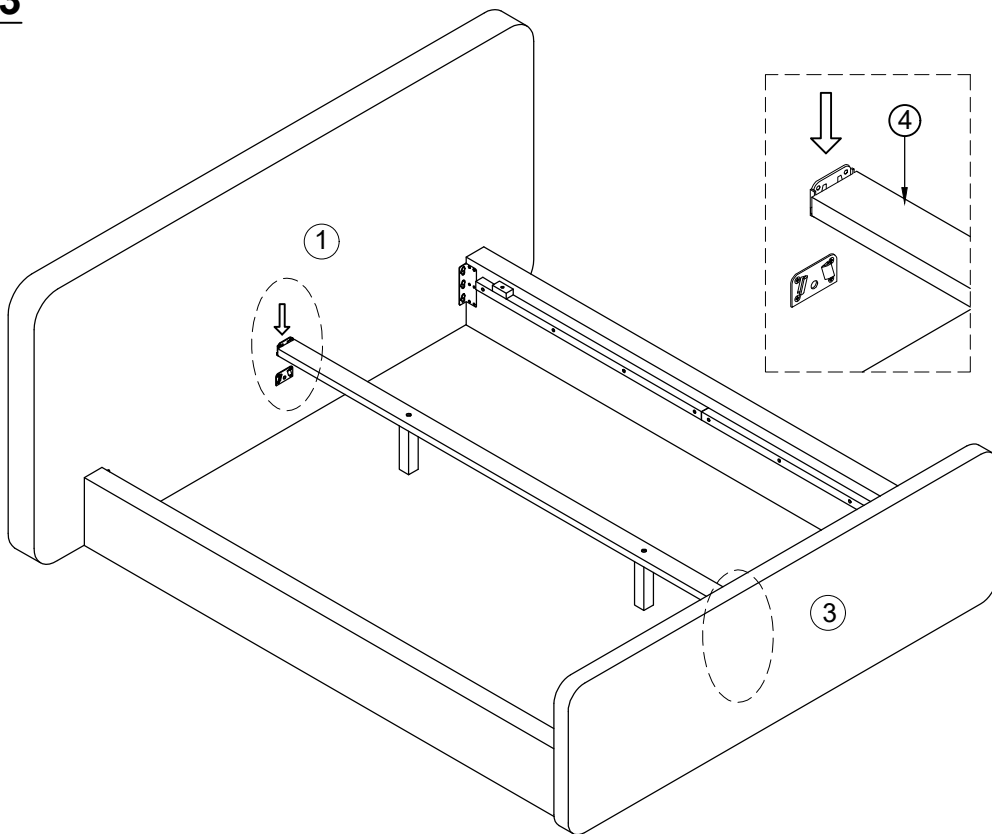

## STEP 4 & FINISH

