

INSTALLATION & ASSEMBLY

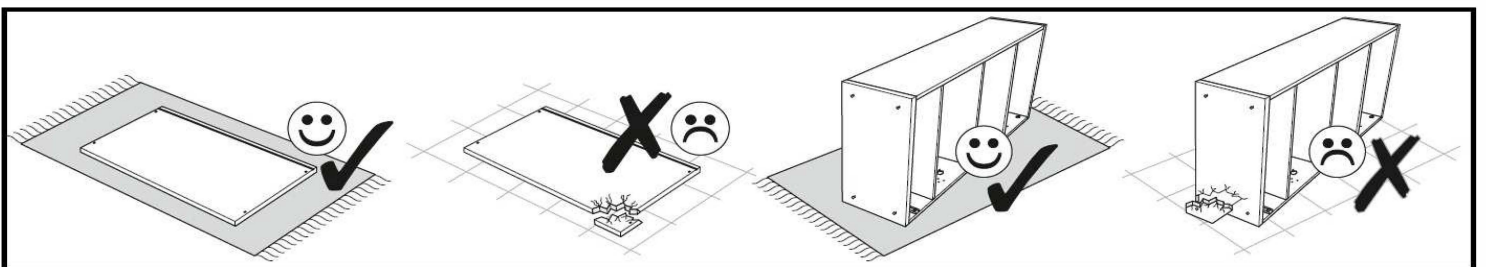
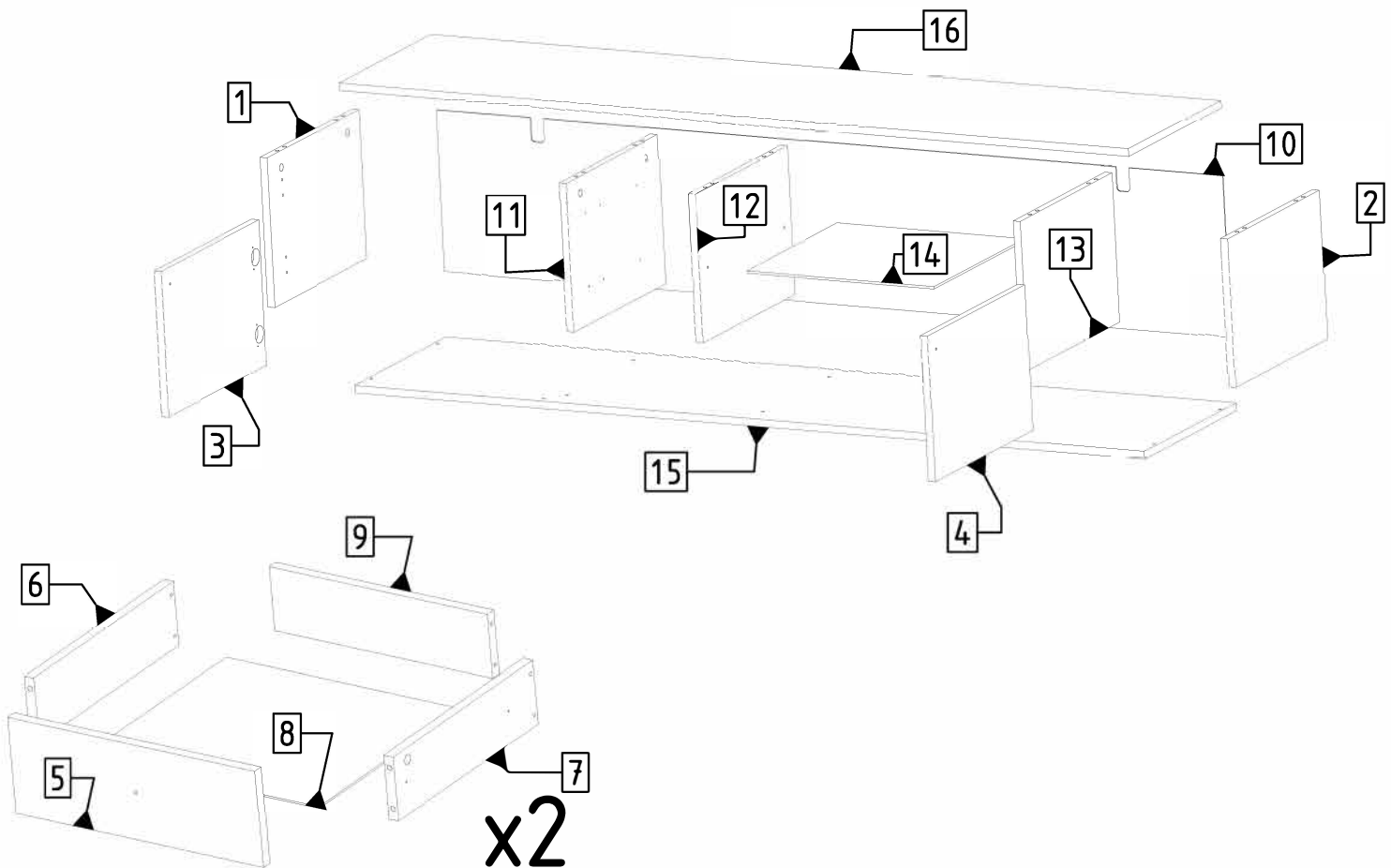
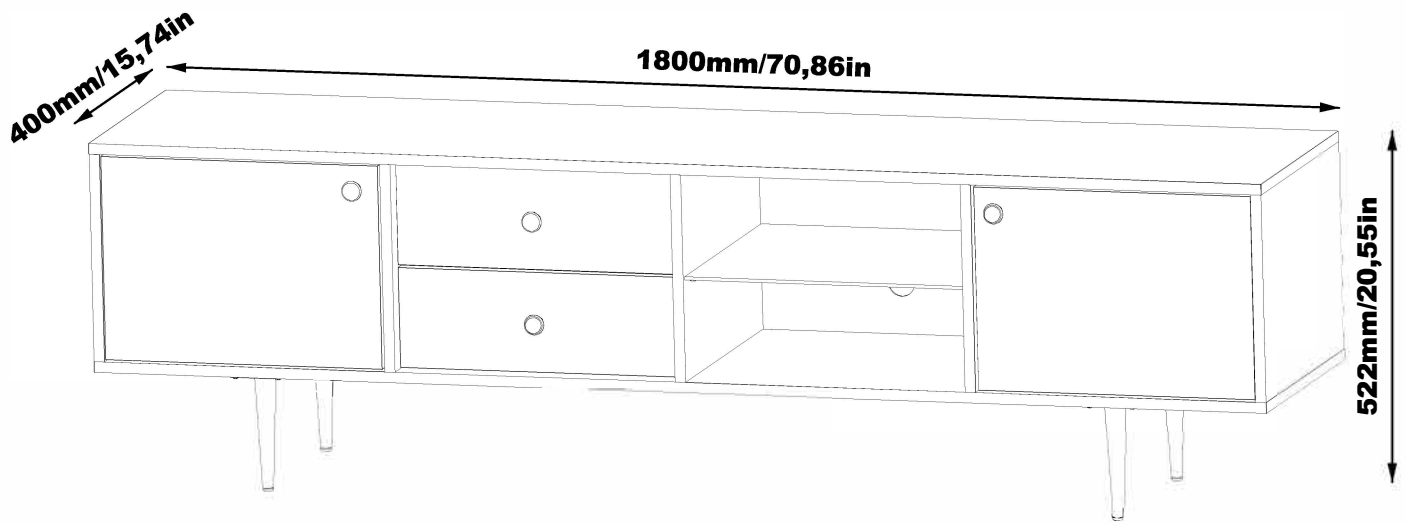
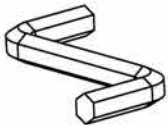
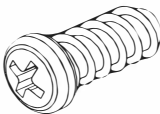

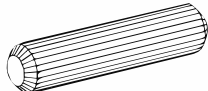
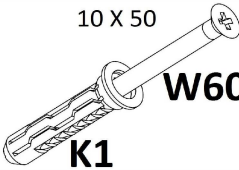

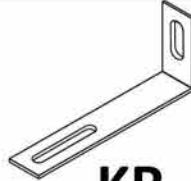

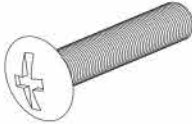

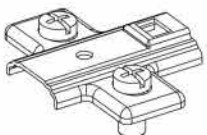

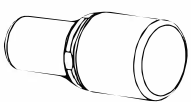

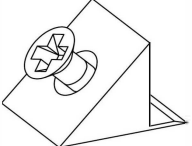
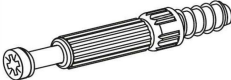



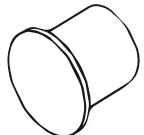
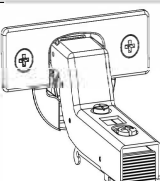
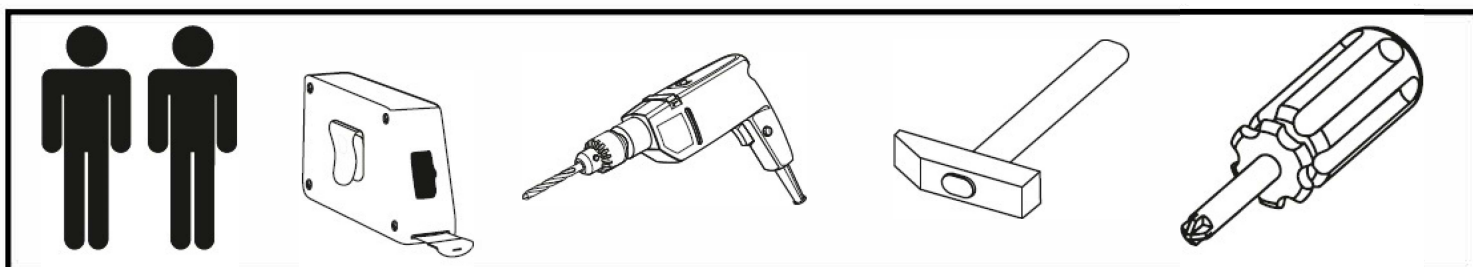
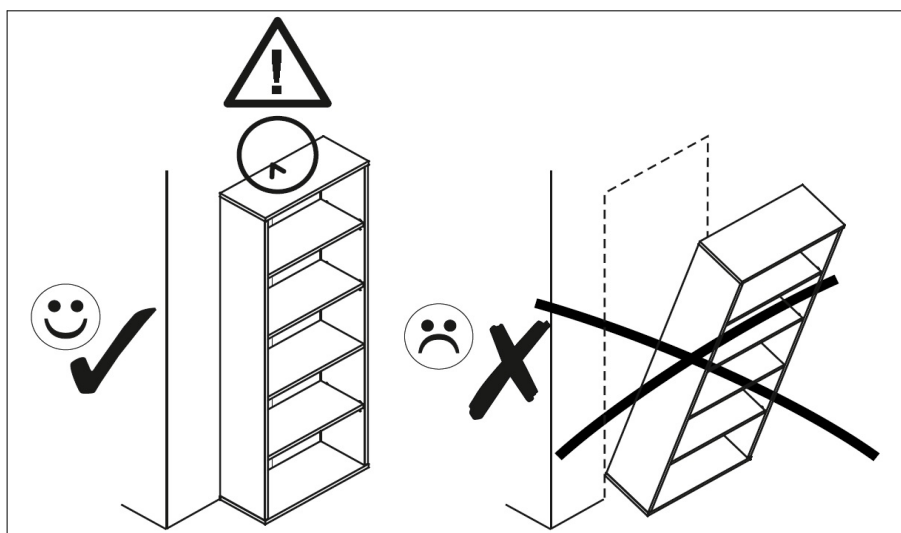

Table accessories

 A1	6,3 X 13  E13	 G	8 x 30  K	10 X 50  W60 K1
6,3 X 50  KN	 KR	15 x 12  M	4X22  M22	h = 200mm  NS
 PE	L350  PKR	 PP3	L350  PWK	 ST
6 x 34 mm  T	 UG2	4 x 16  W16	3 x 16mm  W3	 Z
 Z5	 ZPWH			



Elements				Accessories	
SYMBOL	LENGTH	WIDTH	QUANTITY	SYMBOL	QUANTITY
BL [1]	15.75	12.2	1	A1	1
BP [2]	15.75	12.2	1	E13	16
FT1 [3]	11.97	16.73	1	G	62
FT2 [4]	11.97	16.73	1	K	14
FTS [5]	16.73	5.91	2	K1	2
KBL [6]	13.78	3.94	2	KN	18
KBP [7]	13.78	3.94	2	KR	2
KD [8]	15.83	13.94	2	M	14
KT [9]	14.72	3.94	2	M22	4
PC [10]	70.59	13.23	1	NS (h=200mm)	4
PPI01 [11]	15.75	12.2	1	PE	4
PPI02 [12]	15.75	12.2	1	PKR [L-350]	4
PPI03 [13]	15.75	12.2	1	PP3	6
PS [14]	16.81	15.55	1	PWK [L-350]	4
WD [15]	70.87	15.75	1	ST	4
WG [16]	70.87	15.75	1	T	14
				UG2	4
				W16	12
				W3	20
				W60	2
				Z	14
				Z5	2
				ZPWH	4



PL
UWAGA! Mebel trzeba trwale zamocować do ściany, aby uniknąć przewrócenia się mebla. W paczce są akcesoria przystosowane wyłącznie do ścian betonowych i z pełnej cegły. Jeśli nie jesteś pewien co do budowy ściany, skonsultuj się ze specjalistą.

EN
ATTENTION! The furniture must be permanently attach to the wall, to avoid falling over furniture. There are accessories in the package adapted only to the walls concrete and solid brick. If you are not sure about the constructionwalls, consult expert.

RU
ВНИМАНИЕ! Мебель должна быть постоянно прикрепить к стене, чтобы не упасть мебель. В упаковке есть аксессуары приспособлен только к стенам бетон и твердый кирпич. если Вы не уверены в конструкции стены, проконсультуйтесь специалист.

IT
NOTA! I mobili devono essere permanenti attaccare al muro, per evitare di cadere mobili. Ci sono accessori nel pacchetto adattato solo alle pareti mattone concreto e solido. se non sei sicuro della costruzione muri, consultare specialista.

D
ACHTUNG! Die Möbel müssen dauerhaft seinan der Wand befestigen,um nicht umzufallen Möbel. Es gibt Zubehör in der Verpackung nur an die Wände angepasst Beton und Vollziegel. wenn Sie sind sich nicht sicher über die Konstruktion Wände konsultieren Spezialist.

ES
NOTA! La pieza necesita ser permanentemente pegar a la pared, para evitar caerse muebles. Estan en el paquete accesorios adaptados solo para paredes Hormigón y ladrillo macizo. si no estás seguro de la construcción Paredes, consultar a un especialista.

FR
REMARQUE! La pièce doit être en permanence attacher au mur, pour éviter de tomber meubles. Ils sont dans le paquet accessoires adaptés seulement pour les murs béton et brique pleine. si vous n'êtes pas sûr de la construction murs, consultez un spécialiste.

CZ
POZOR! Kus musí být natrvalo připevnit ke zdi, aby se zabránilo pádu nábytek. Jsou v balení příslušenství přizpůsobené pouze pro stěny betonové a pevné cihly. pokud Nejste si jistí stavbou konzultovat odborníka.

SLO
POZOR! Kus musí byť natrvalo pripojit' k stene, aby sa zabránilo pádu nábytok. Sú v balení príslušenstvo prispôsobené len pre steny betón a pevné tehly. ak Nie ste si istý stavbou konzultujte s odborníkom.

1.

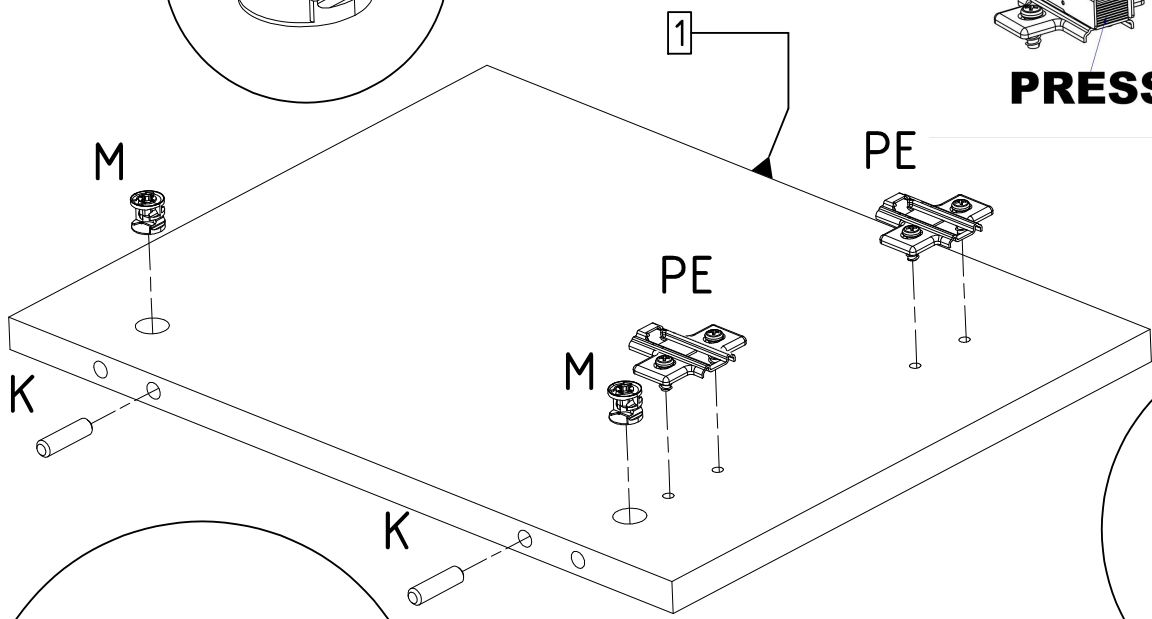
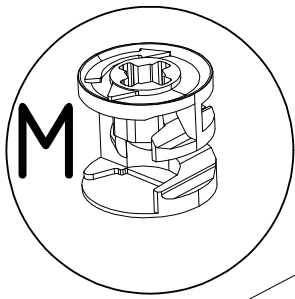

1.



2.

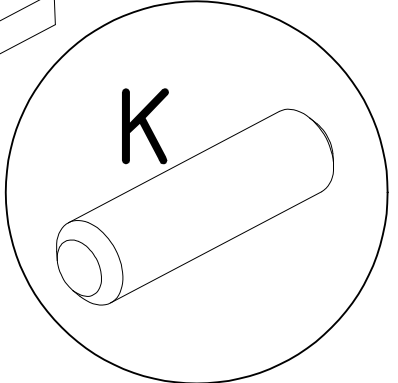
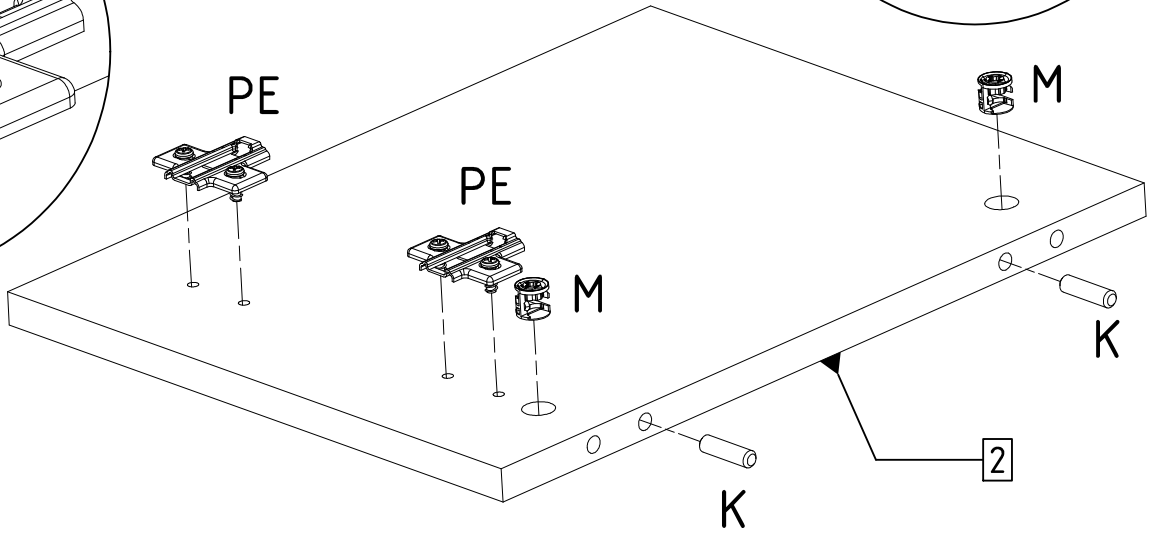
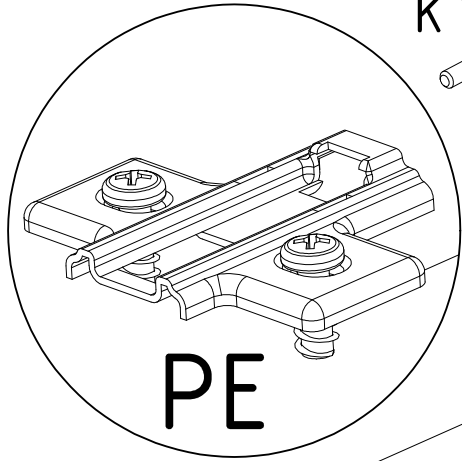
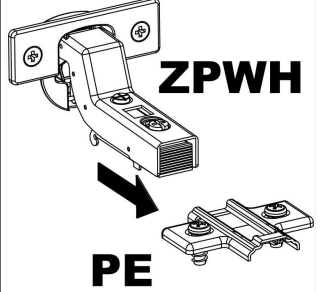

13

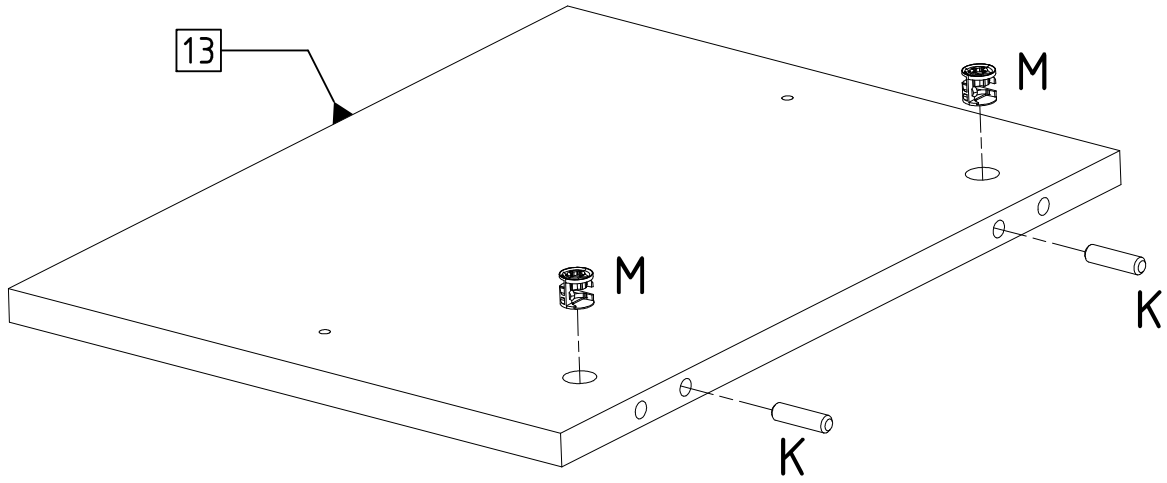

2.

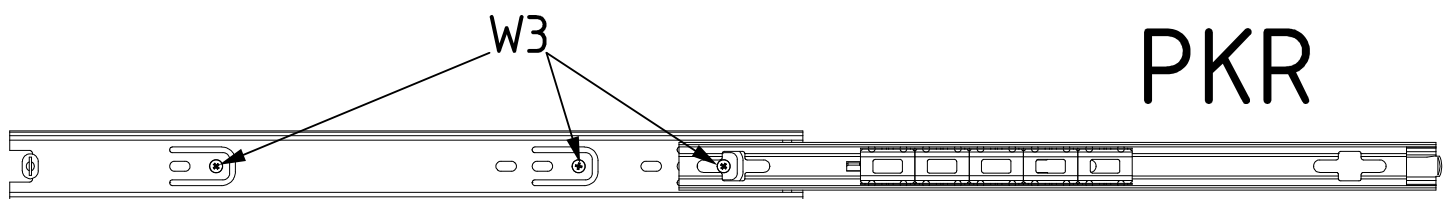
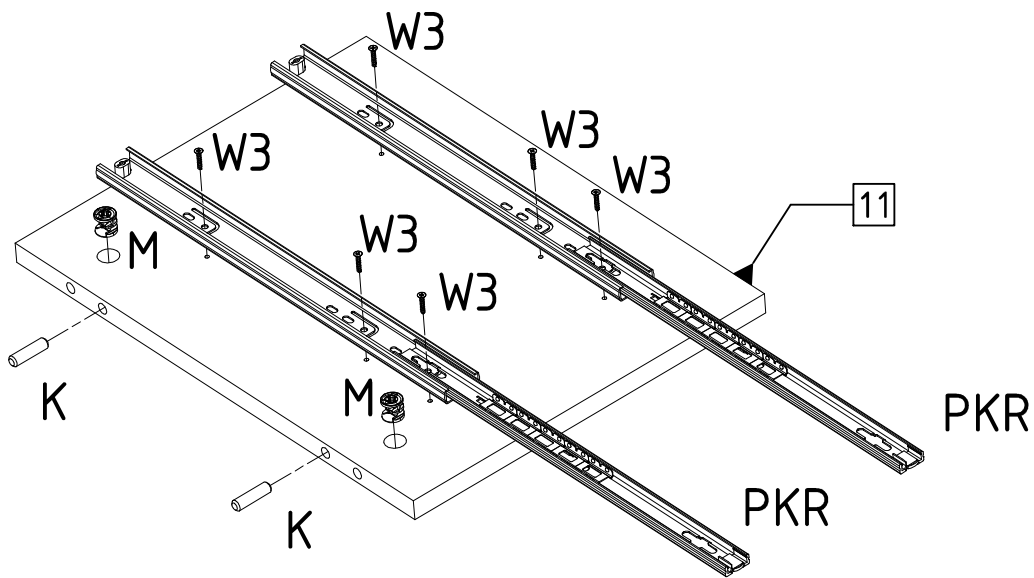
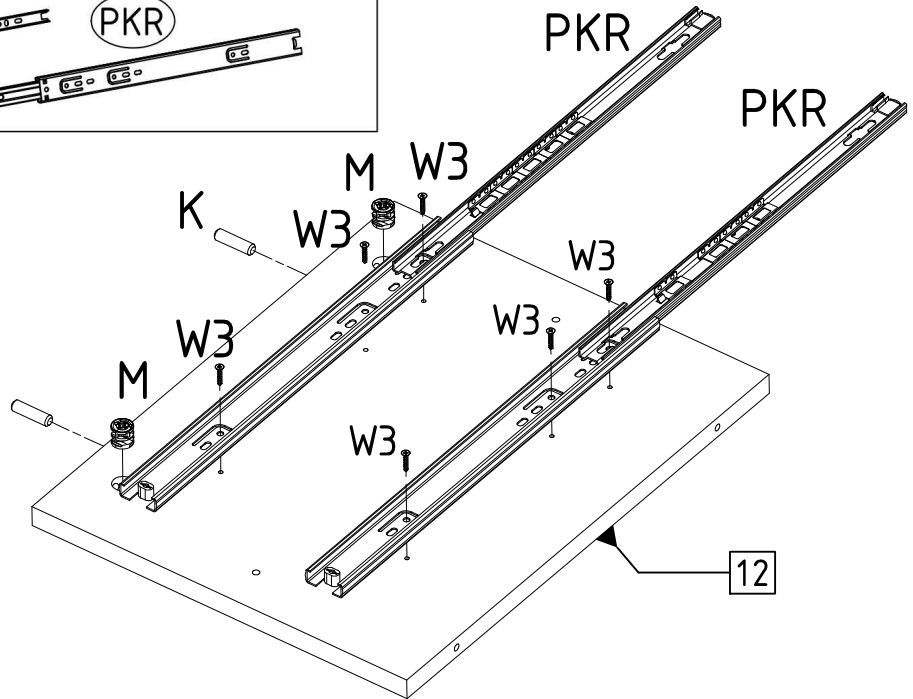
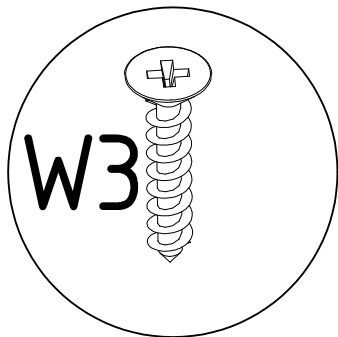
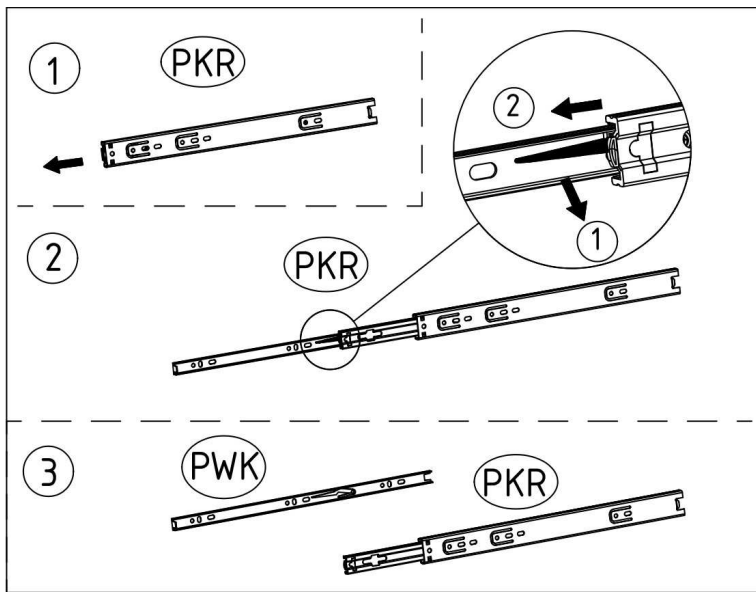

3.

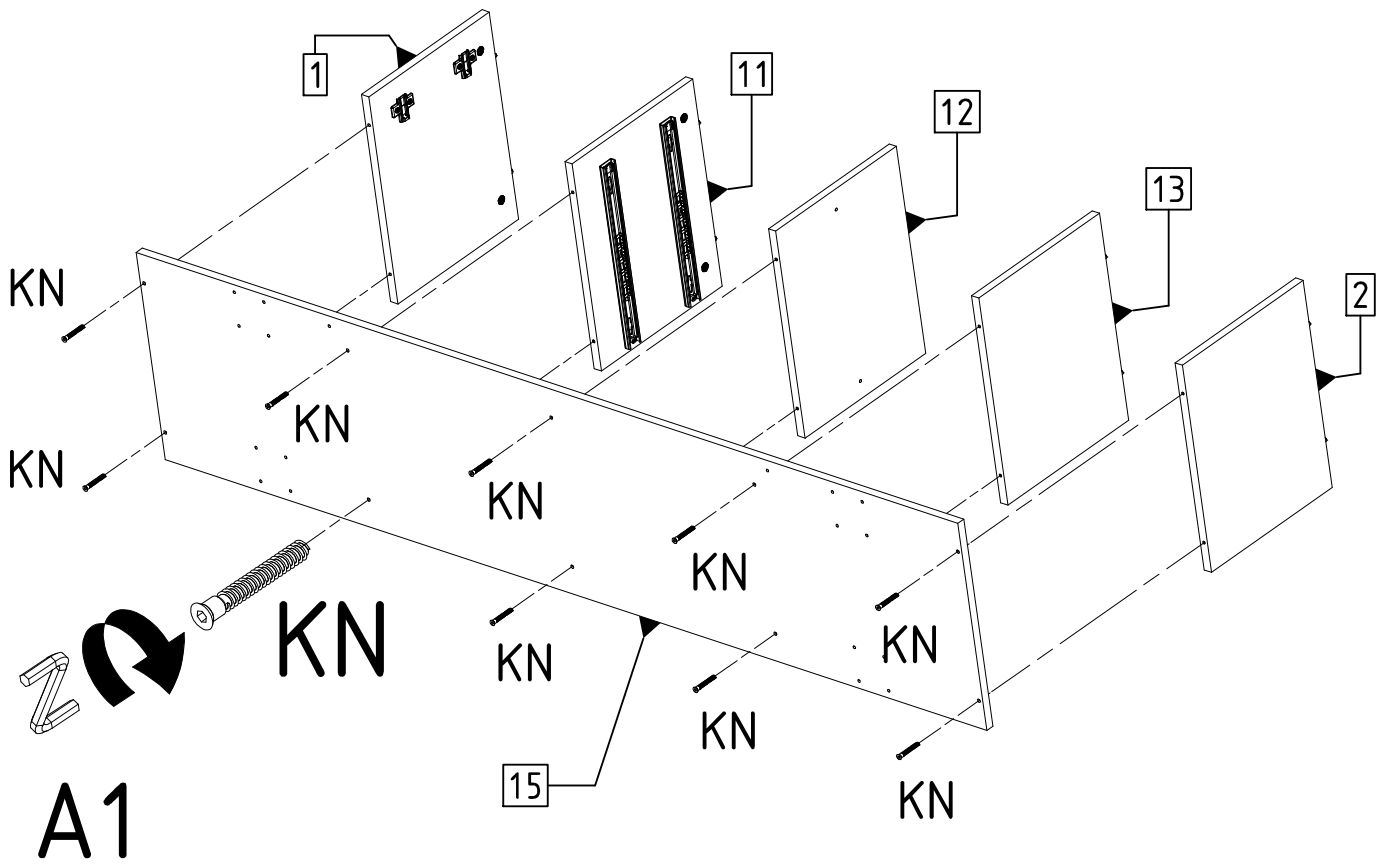

4.

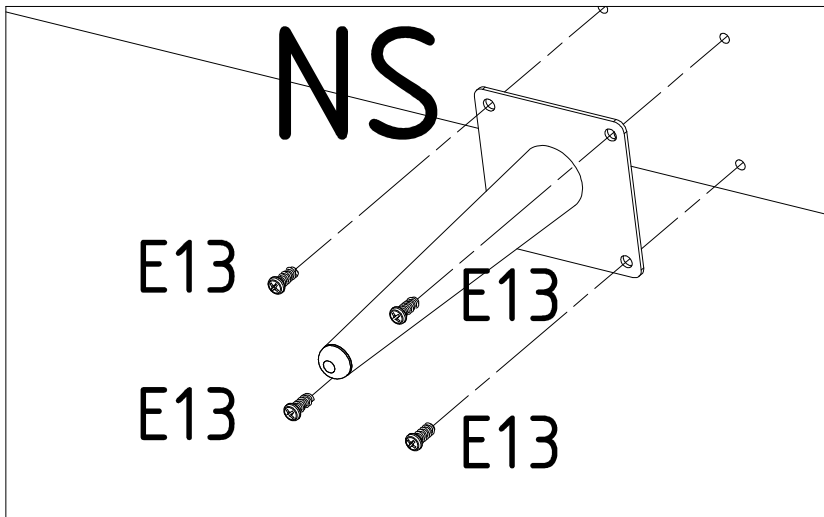
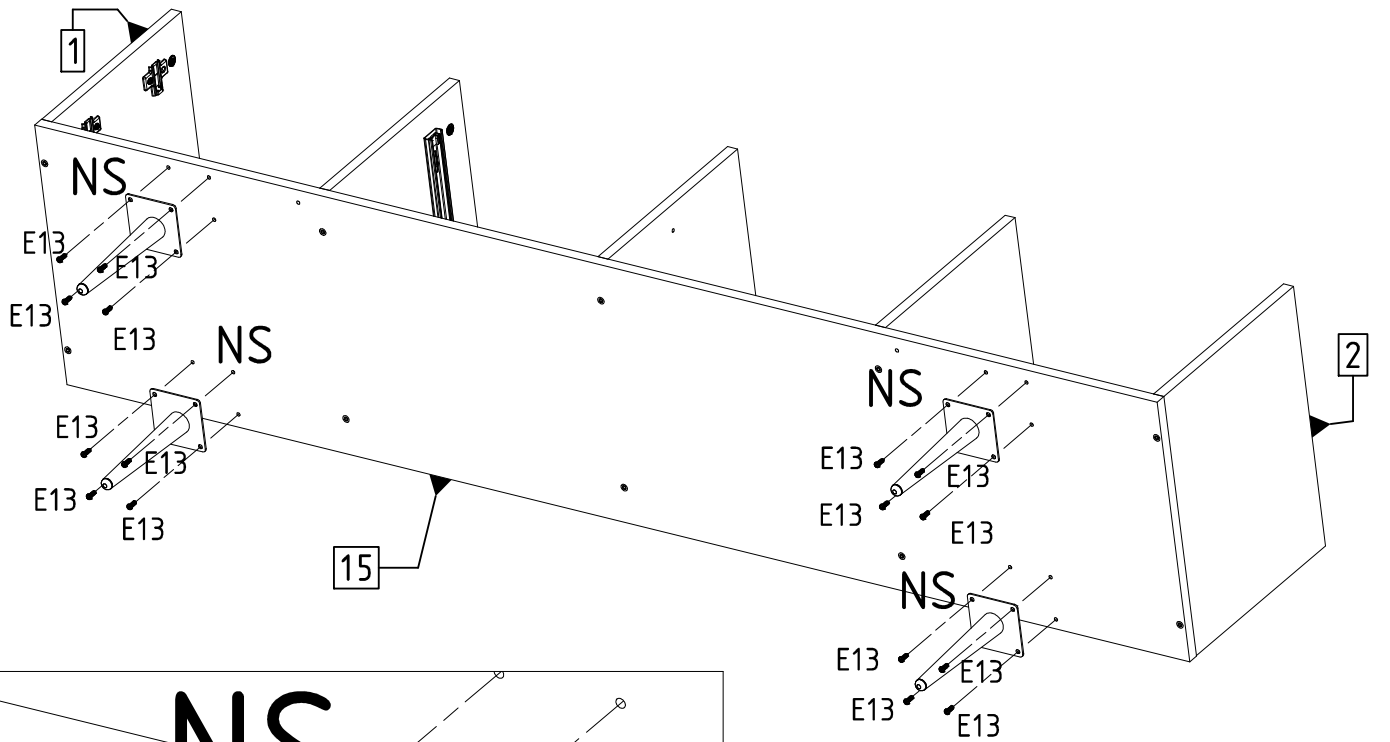

5.

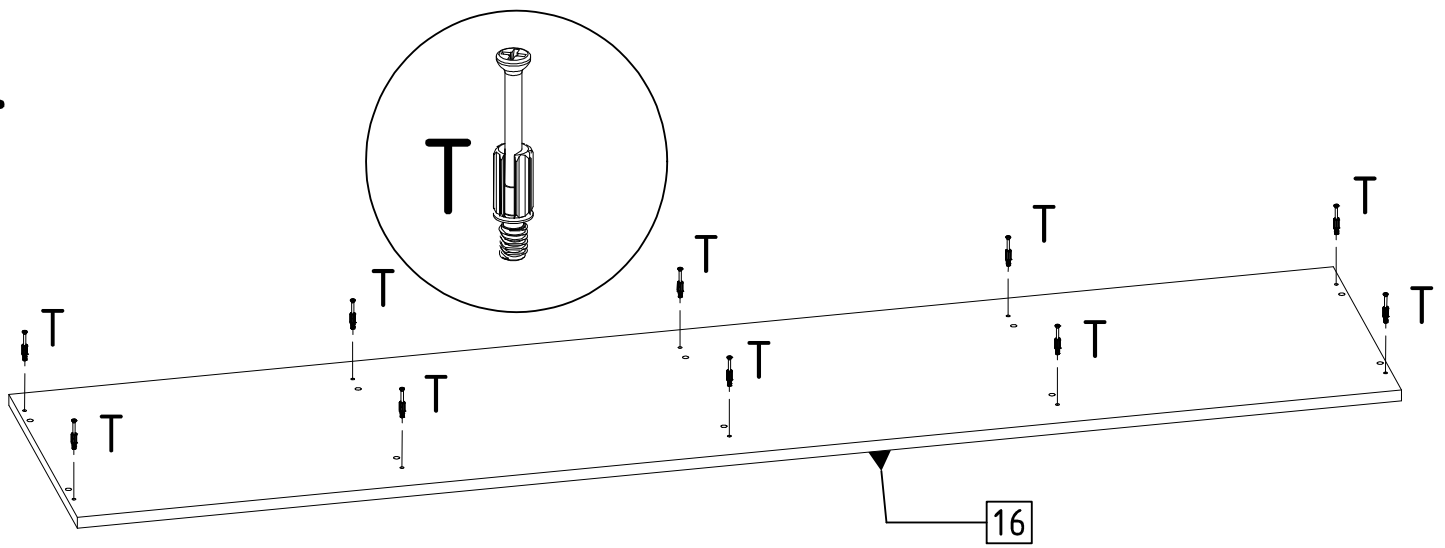

6.

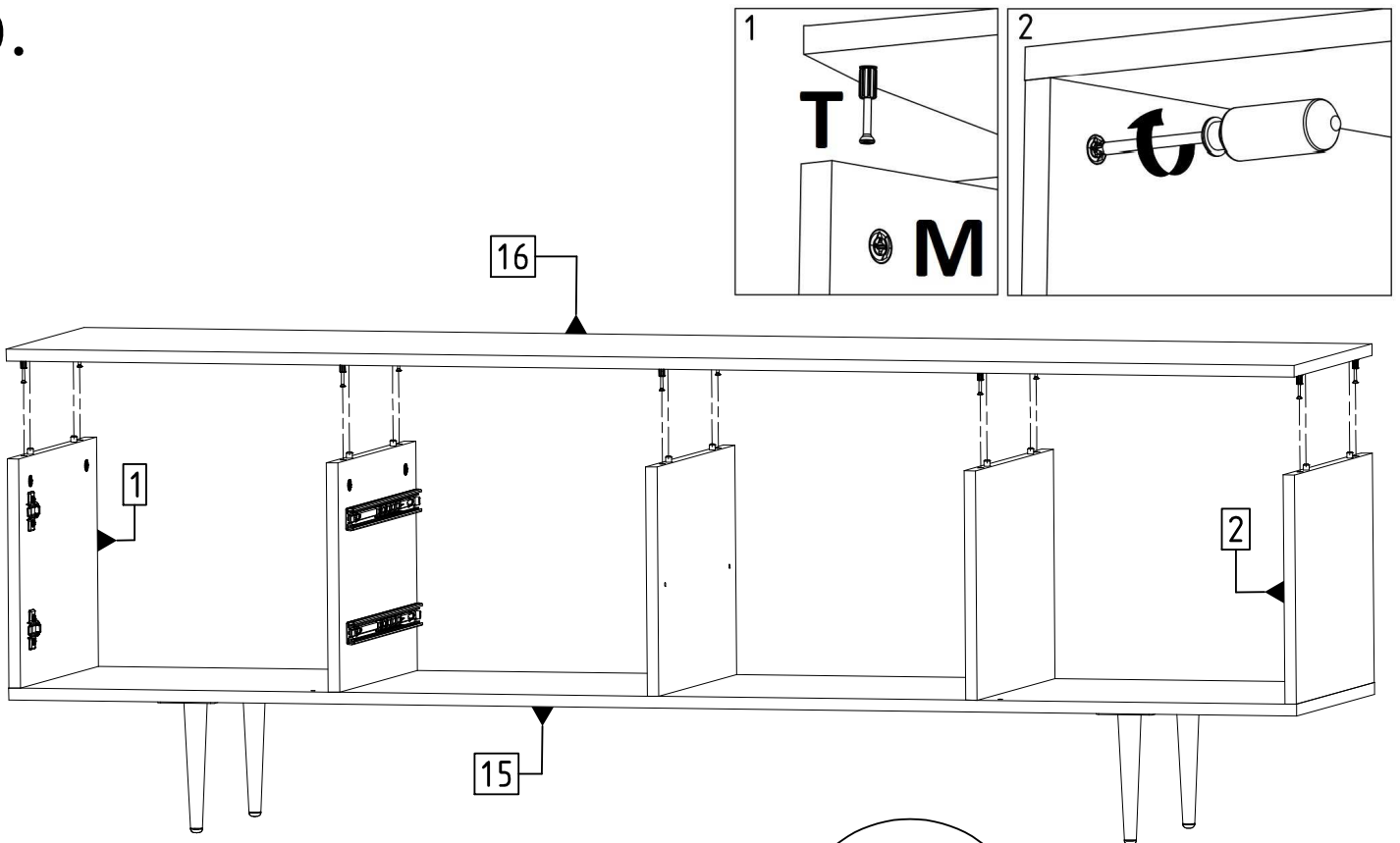

7.

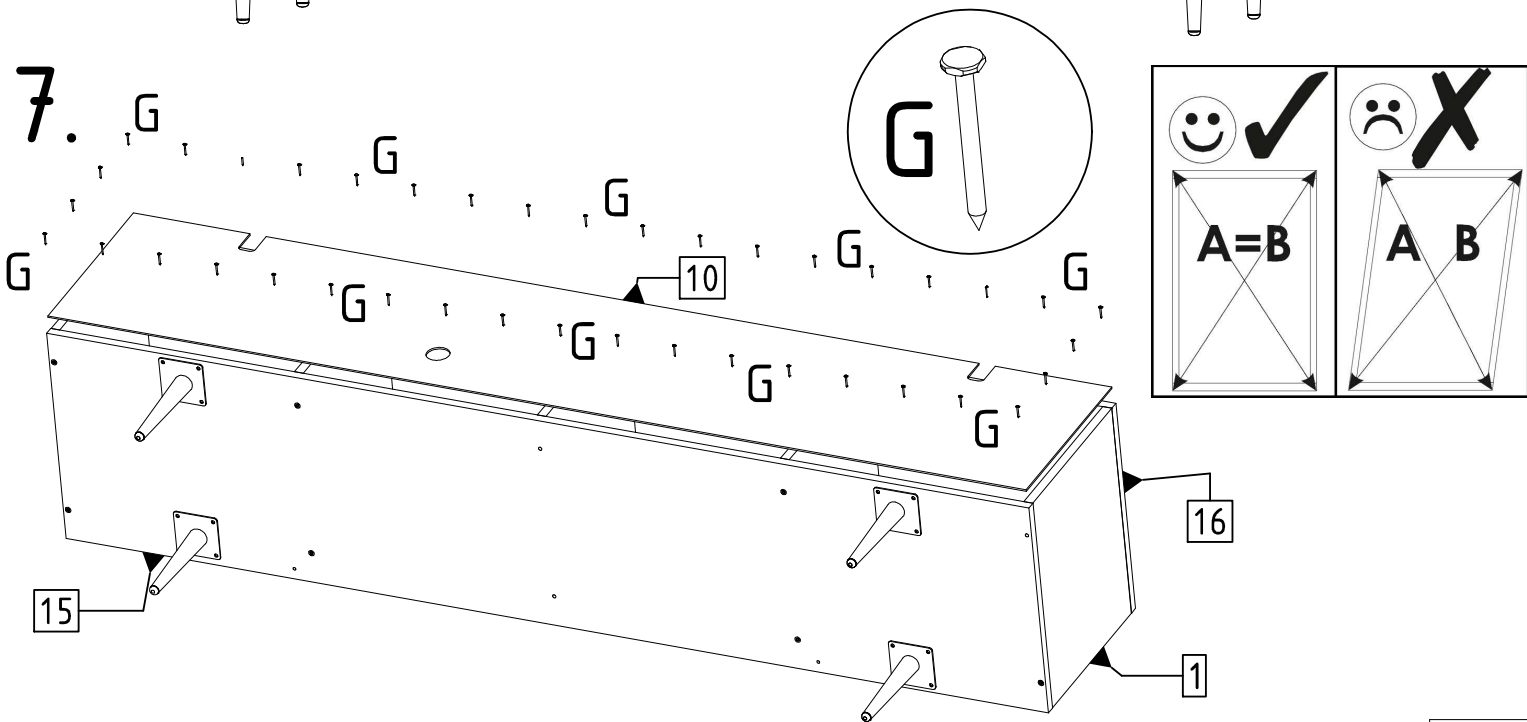

8.

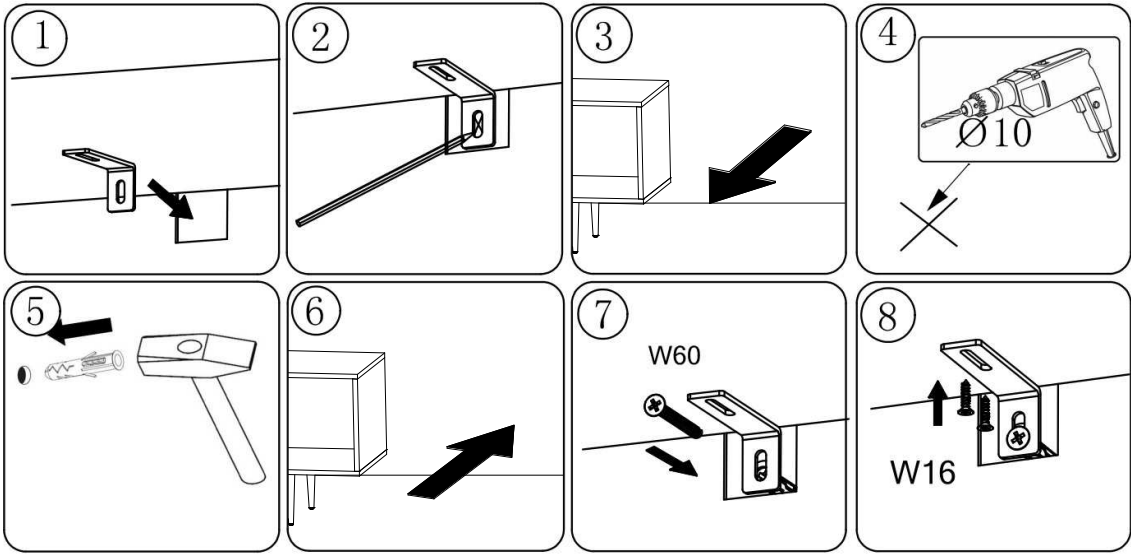
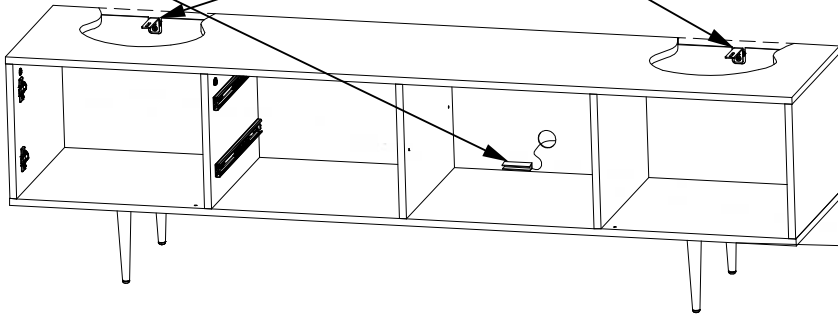
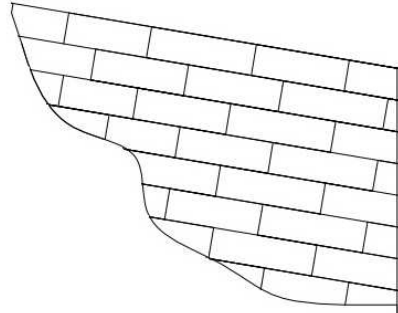
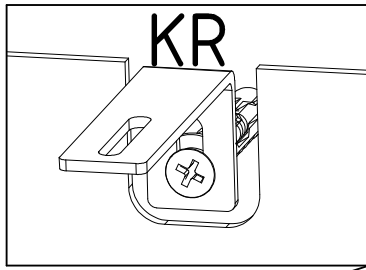
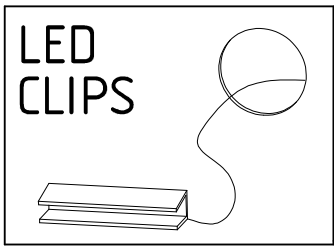

9.

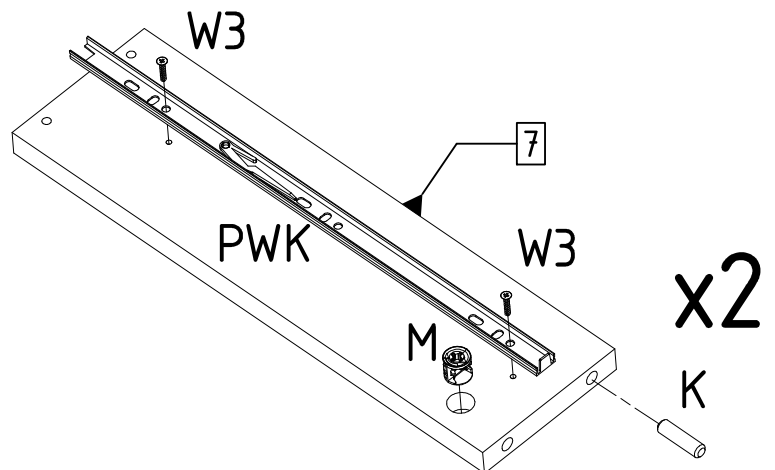
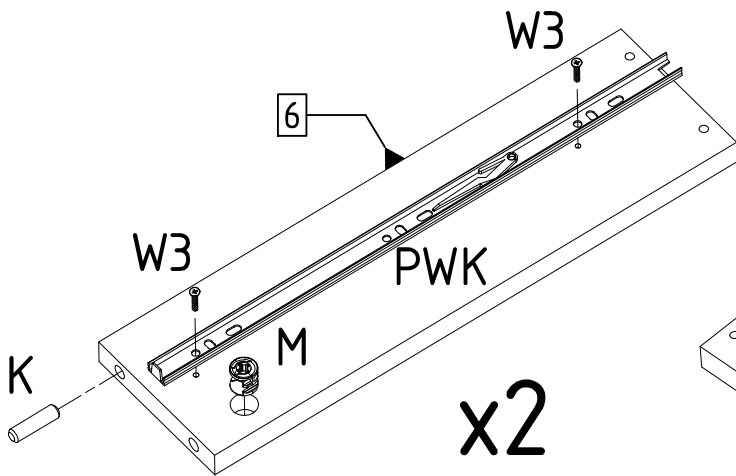

14.

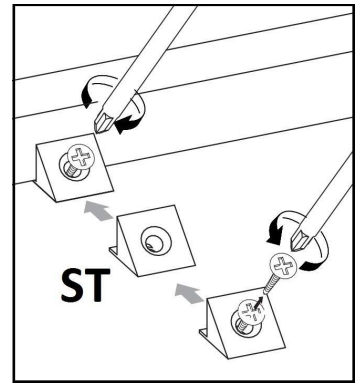
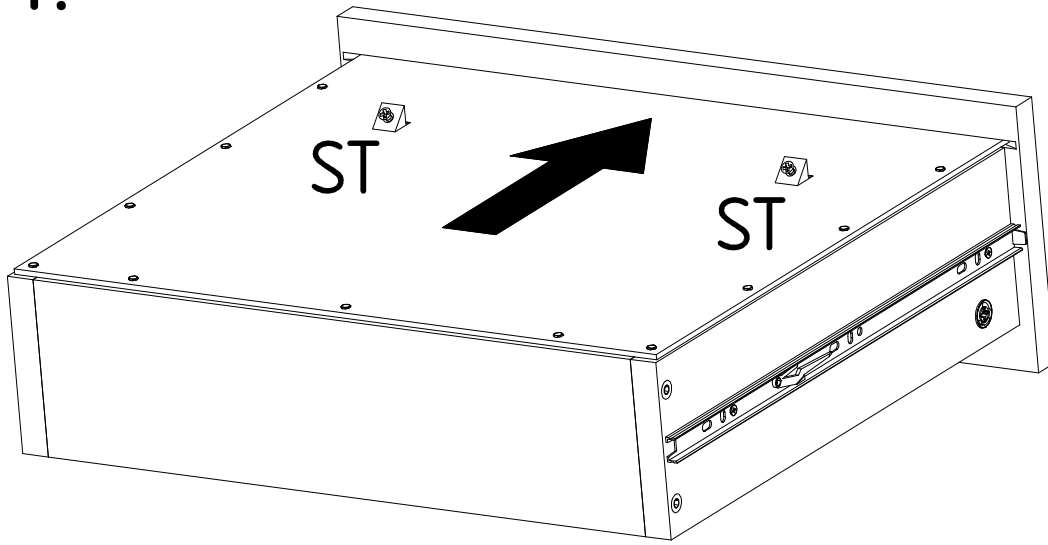

15.

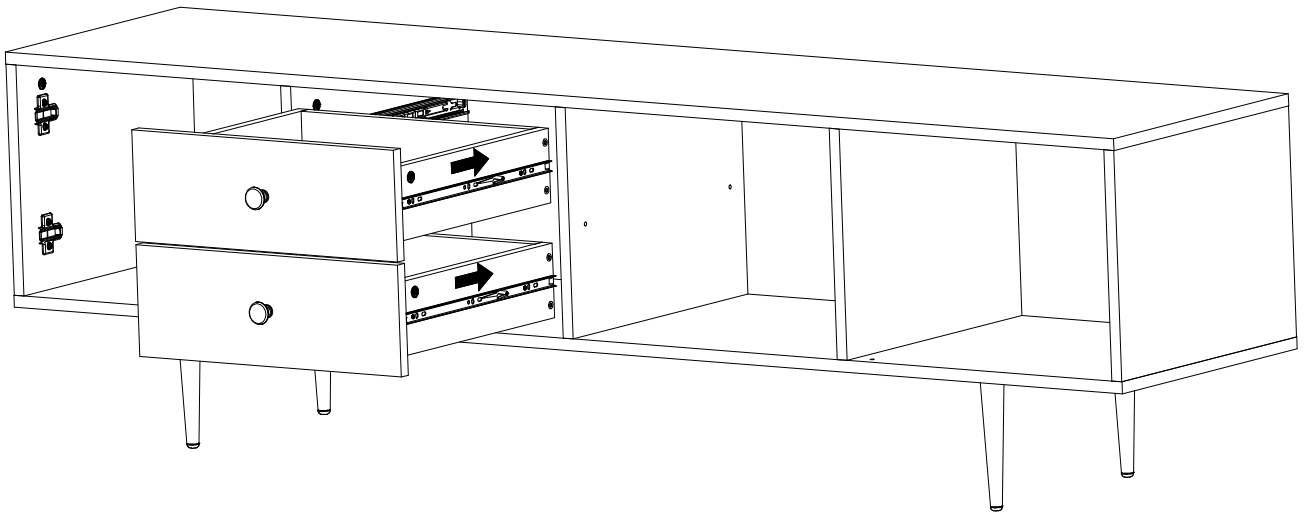

16.

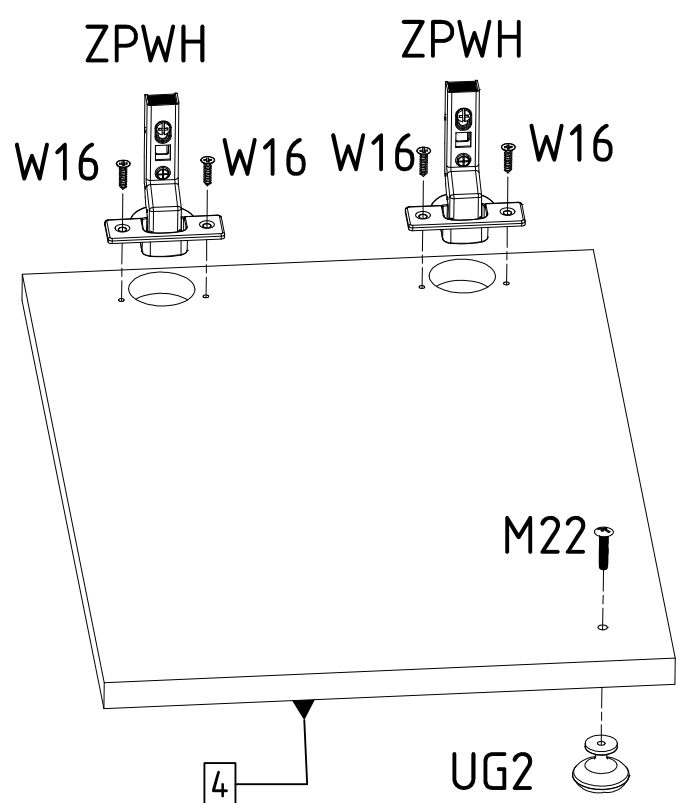
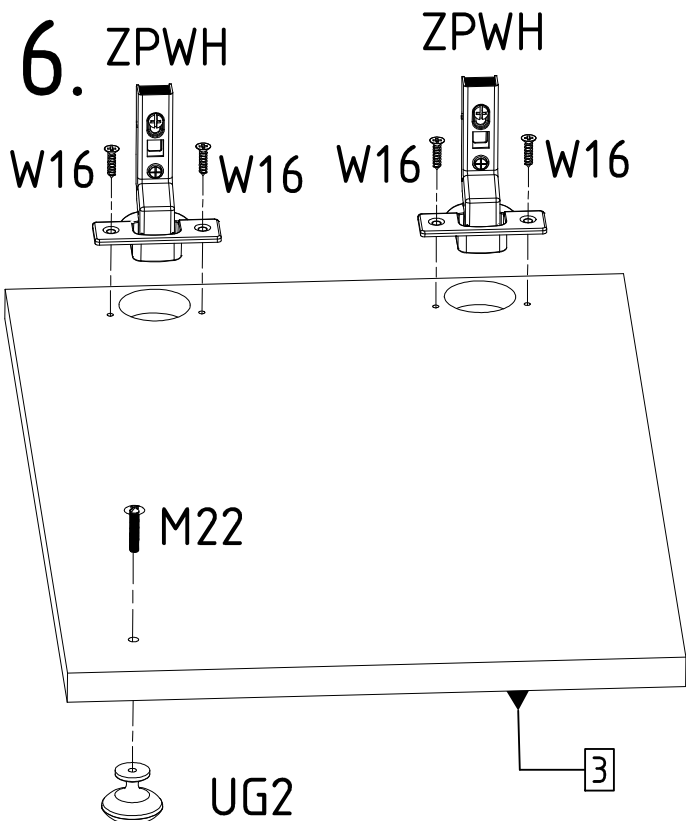

17.

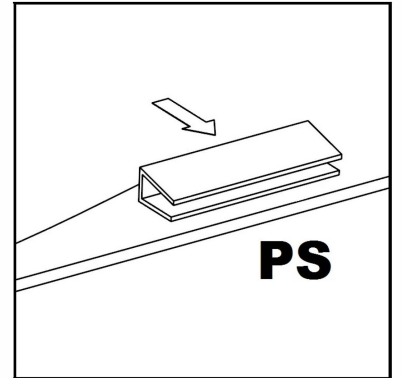
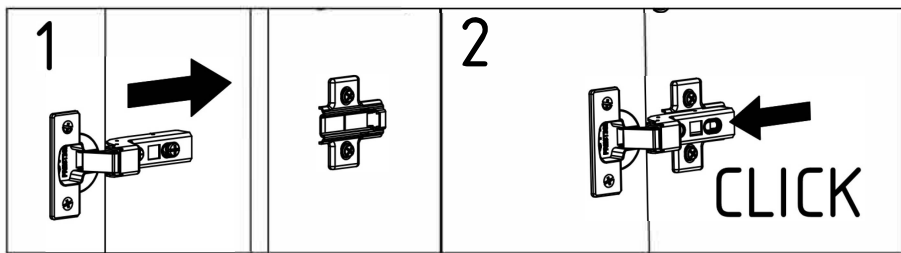
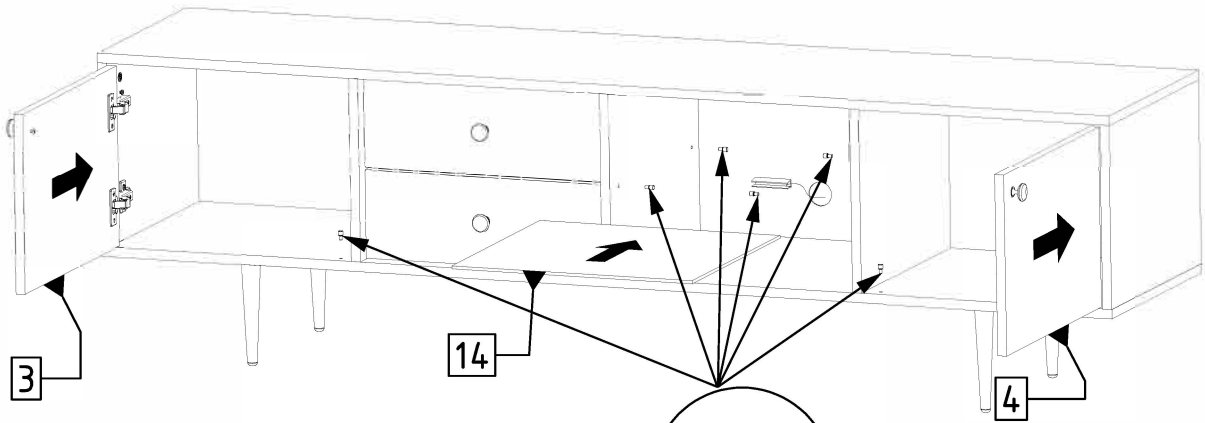

18.

