



Wine chiller

Model# JC-34,JC-48,JC-53,JC-82,JC-85

USER MANUAL



Thanks for your purchase. Any questions please don't hesitate to contact us, We will handle all your problem ASAP. Your feedback is vital to us! And we will always try to do better. For more details, please contact us by email via support@rovsun.com. (Write your seller's Order # on the subject of the email, so that we can find your order and better assist your issue) Or call us at (1)855-882-2333.

IMPORTANT SAFETY INSTRUCTIONS

⚡WARNING⚡

To reduce the risk of fire, electrical shock, or injury when using your appliance, follow these basic precautions:

- Before using the appliance, please read this user manual to ensure that you gain the maximum benefit from it.

WARNING:

1. This appliance is not intended for use by persons (including children) with reduced physical, sensory or mental capabilities, or lack of experience and knowledge, unless they have been given supervision or instruction concerning use of the appliance by a person responsible for their safety.
2. Children should be supervised to ensure that they do not play with the appliance.
3. This appliance can be used by children aged from 8 years and above and persons with reduced physical, sensory or mental capabilities or lack of experience and knowledge if they have been given supervision or instruction concerning use of the appliance in a safe way and understand the hazards involved. Children shall not play with the appliance. Cleaning and user maintenance shall not be made by children without supervision.
4. If the supply cord is damaged, it must be replaced by the manufacturer, its service agent or similarly qualified persons in order to avoid a hazard.
5. To avoid a hazard due to instability of the appliance, it must be fixed in accordance with the instructions.
6. When positioning the appliance, ensure the supply cord is not trapped or damaged.
7. Do not locate multiple portable socket-outlets or portable power supplies at the rear of the appliance.
8. Keep ventilation openings, in the appliance enclosure or in the built-in structure, clear of obstruction.
9. Do not use mechanical devices or other means to accelerate the defrosting process, other than those recommended by the manufacturer.
10. Do not damage the refrigerant circuit.
11. Do not use electrical appliances inside the drink storage compartments of the appliance, unless they are of the type recommended by the manufacturer.
12. Do not store explosive substances such as aerosol cans with a flammable propellant in this appliance.
13. This appliance is intended to be used in household and similar applications such as
 - staff kitchen areas in shops, offices and other working environments;
 - farm houses and by clients in hotels, motels and other residential type environments;
 - bed and breakfast type environments;
 - catering and similar non-retail applications.
14. Children aged from 3 to 8 years are allowed to load and unload refrigerating appliances.
15. To avoid contamination of drink, please respect the following instructions:
 - Opening the door for long periods can cause a significant increase of the temperature in the compartments of the appliance.
 - Clean regularly surfaces that can come in contact with drink and accessible drainage systems.
 - Clean water tanks if they have not been used for 48 h; flush the water system connected to a water supply if water has not been drawn for 5 days.
 - If the refrigerating appliance is left empty for long periods, switch off, defrost, clean, dry, and leave the door open to prevent mould developing within the appliance.

- Note: This appliance contains flammable refrigerant R600a and foaming agent cyclopentane. Please avoid contact fire when you transport and use it.
Please ask professional for servicing when the machine broke down.
Please send it to your local appointed disposal station when you discard it.

-Save these instructions-

Correct disposal of this product



This symbol on the product, or in its packaging, indicates that this product may not be treated as household waste. Instead, it should be taken to the appropriate waste collection point for the recycling of electrical and electronic equipment. By ensuring this product is disposed of correctly, you will help prevent potential negative consequences for the environment and human health, which could otherwise be caused by the inappropriate waste handling of this product. For more detailed information about the recycling of this product, please contact your local council, your household waste disposal service, or the shop where you purchased the product.

INSTALLATION INSTRUCTIONS

- This appliance is designed to be free standing only, and should not be recessed or built-in.
- Place your unit on a floor that is strong enough to support the unit when it is fully loaded. To level your unit, adjust the leveling leg at the bottom of the unit
- This appliance is NOT designed to be installed inside of a cabinet where the front is covered by any type of door.
- Allow 7cm of space between the top, back and sides of the unit, which allows the proper air circulation to cool the compressor and condenser
- Locate the unit away from direct sunlight and sources of heat (stove, heater, radiator, etc.) Direct sunlight may affect the acrylic coating and heat sources may increase electrical consumption. Extreme cold ambient temperatures may also cause the unit not to perform properly.
- Avoid locating the unit in moist areas.
- Plug the unit into an exclusive, properly installed-grounded wall outlet. Do not under any circumstances cut or remove the third (ground) prong from the power cord. Any questions concerning power and/or grounding should be directed toward a certified electrician or an authorized Products service center.
- After plugging the appliance into a wall outlet, allow the unit to cool down for 2-3 hours before placing food in the APPKIANCE compartment.

Remark: Please remember to keep some water in the cabinet to keep the humidity

For disposal of the appliance:

To prevent possible harm to the environment or human health from uncontrolled waste disposal, recycle it responsibly to promote the sustainable reuse of material resources. And the disposal should only be done through public collection points.

For installation, servicing:

Appliance should placed on a horizontal floor and keep the ventilation freely. don't try to replace or repair any components by yourself, ask the service agency for help if necessary.

For handling:

Always handle the appliance to avoid any damage.



OPERATING YOUR UNIT

Setting the Temperature Control





- * At the beginning you power on the wine cooler, the ambient temperature is the same as the internal temperature.
- * The temperature display window is showing the real internal temperature, that will help us to check the temperature at any time.

Your wine cooler has been equipped with an “automatic” control panel lock, that will activate 20 seconds after the last time a button has been touched.

Push button  simultaneously for 2 seconds to unlock the control panel. You will hear a “BEEP” sound to alter you that the control is now active. You can select temperature display setting from Fahrenheit to Celsius degree by pushing button  for 2 second. The degrees will appear in blue color in the temperature display window.

When the control panel is active, push button  and the LED temperature display will be off; You have to push the button again and the LED temperature display will turn back on.

You can set the temperature as you desire by pushing button . The temperature that you desire to set will increase 1°F or 1°C if you push the button once.

You can set the temperature as you desire by pushing button . The temperature that you desire to set will decrease 1°F or 1°C if you push the button once.

Energy Saving Tips

- The unit should be located in the coolest area of the room, away from heat producing appliances, and out of the direct sunlight.
- Let hot foods cool to room temperature before placing in the unit. Overloading the unit forces the compressor to longer.
- Be sure to wrap foods properly, and wipe containers dry before placing them in the unit. This cuts down on frost build-up inside the unit.
- Unit storage bin should not be lined with aluminum foil, wax paper, or paper toweling. Liners interfere with cold air circulation, making the unit less efficient.
- Organize and label food to reduce door openings and extended searches. Remove as many items as needed at one time, and close the door as soon as possible.

PROBLEMS WITH YOUR APPLIANCE

You can solve many common problems easily, saving you the cost of a possible service call. Try the suggestions below to see if you can solve the problem before calling the servicer.

TROUBLESHOOTING GUIDE

PROBLEM	POSSIBLE CAUSE
Unit does not operate.	Not plugged in. The circuit breaker tripped or a blown fuse.
Turns on and off frequently.	The room temperature is hotter than normal. A large amount of food has been added to the unit. The door is opened too often. The door is not closed completely. The temperature control is not set correctly. The door gasket does not seal properly. The unit does not have the correct clearances.
Vibrations.	Check to assure that the unit is level.
The unit seems to make too much noise.	The rattling noise may come from the flow of the refrigerant, which is normal. As each cycle ends, you may hear gurgling sounds caused by the flow of refrigerant in your unit. Contraction and expansion of the inside walls may cause popping and cracking noise. The unit is not level.
The door will not close properly.	The unit is not level. The door was reversed and not properly installed. The gasket is dirty or bent. The shelves, bins, or baskets are out of position.

WIRING DIAGRAM

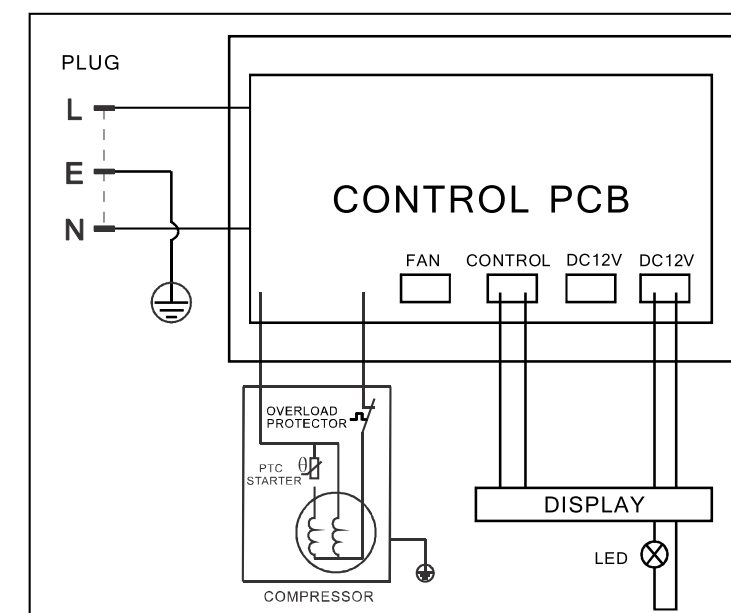

Made in China