

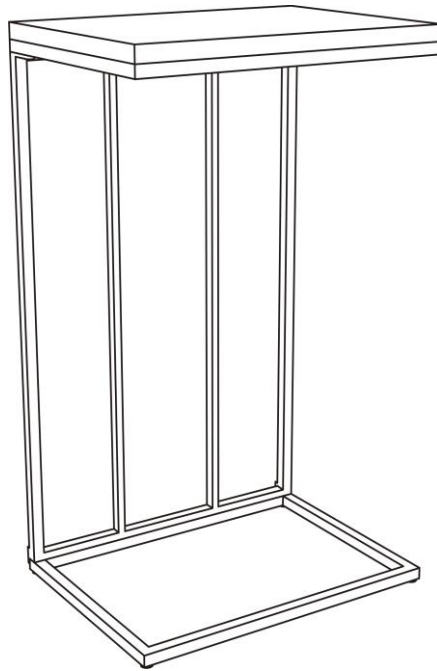



Assembly Instructions

Caution : You must read this before you proceed



End Table



Parts List

Label	Picture	Description	QTY
A		Table Top	1
B		Support Bar	1
C		Leg	1

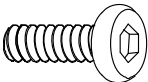
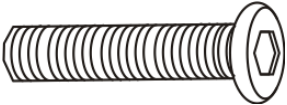
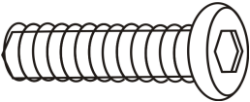
Hardware

Label	Picture	Description	QTY
①		Washer	12
②		Bolt(M6*16MM)	5
③		Bolt(M6*30MM)	4
④		Bolt(M6*20MM)	3
⑤		Allen Wrench	1

Assembly Preparation

Before Beginning Assembly:

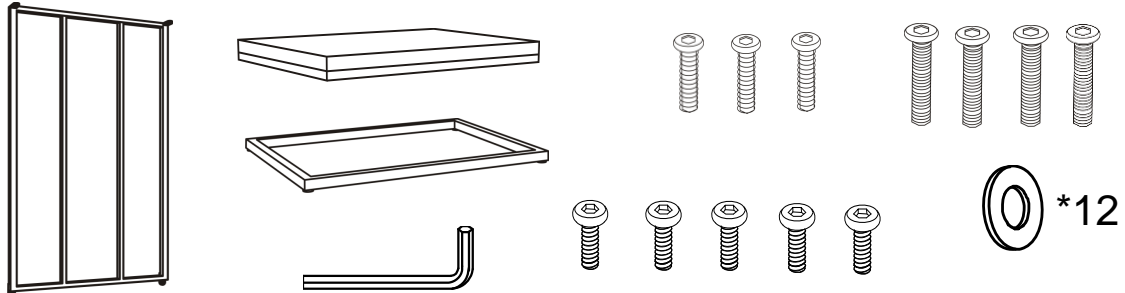

The illustration shows the components for assembly preparation: a shower door frame, two panels, an Allen wrench, and various bolts and washers. The bolts are arranged in two groups: one group with 5 bolts of different lengths and one group with 4 bolts of the same length. The washers are arranged in a group of 12.



- Read instructions, cover to cover-



- Have 2 adults on hand for assembly-



- Do not assemble on flooring or carpet-



- Assemble on a clean non-marring surface (packing foam)-



- Save all packaging until finished-

Assembly Steps

Parts Introduction

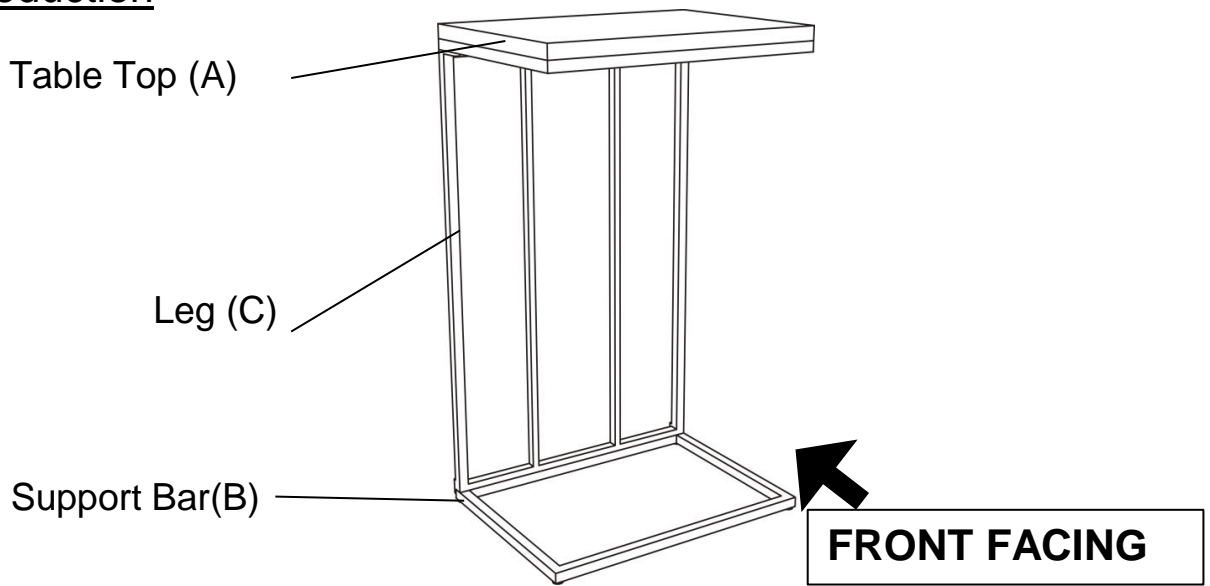

This Table has multiple parts and may require up to some 30 minutes to assemble.

To give you an overview of the Table parts, the above picture is to help you put the various parts into perspective.

Please read through the instructions herebelow to familiarise the parts and steps before assembly.

Step 1

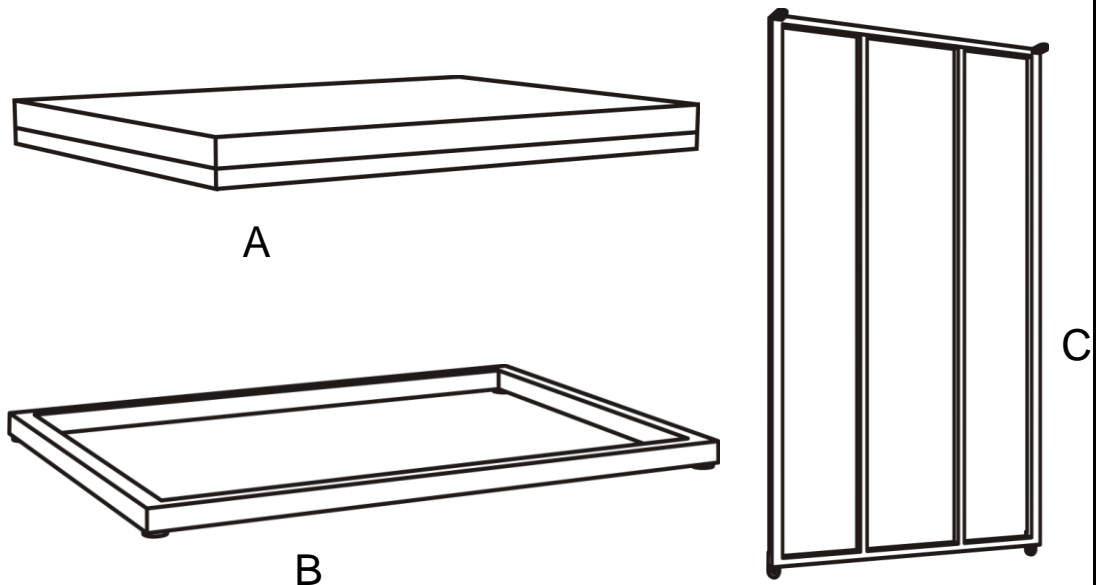

Open the carton and place all the parts onto a clean, non-marring surface.

Step 2

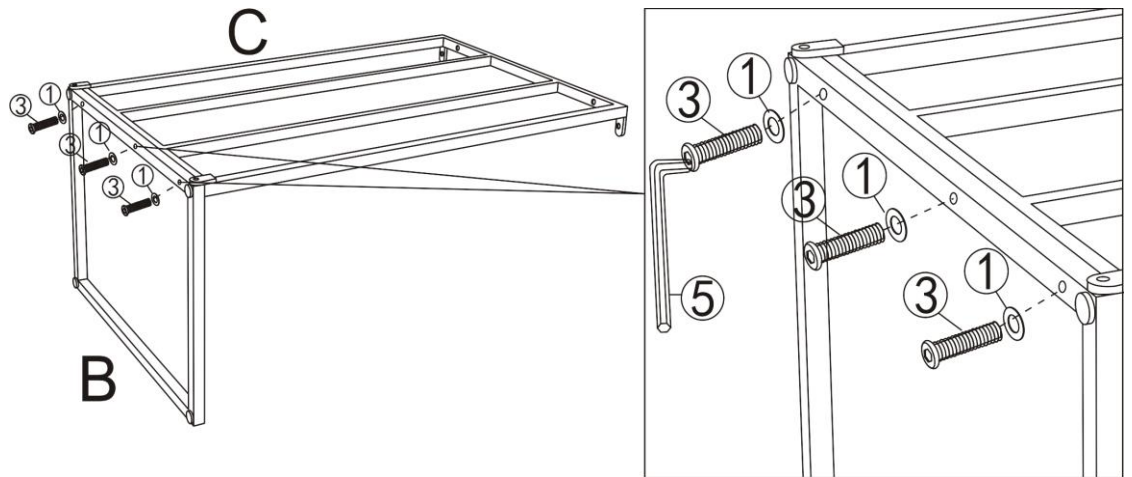

Align the mounting positions on the Support Bar(B) and the Leg(C), Then attach Leg(C) to Support Bar(B) using Washer(①) and Bolt(③) with Allen Wrench(⑤) as shown.
Do not fully tighten the Bolts.

Step 3

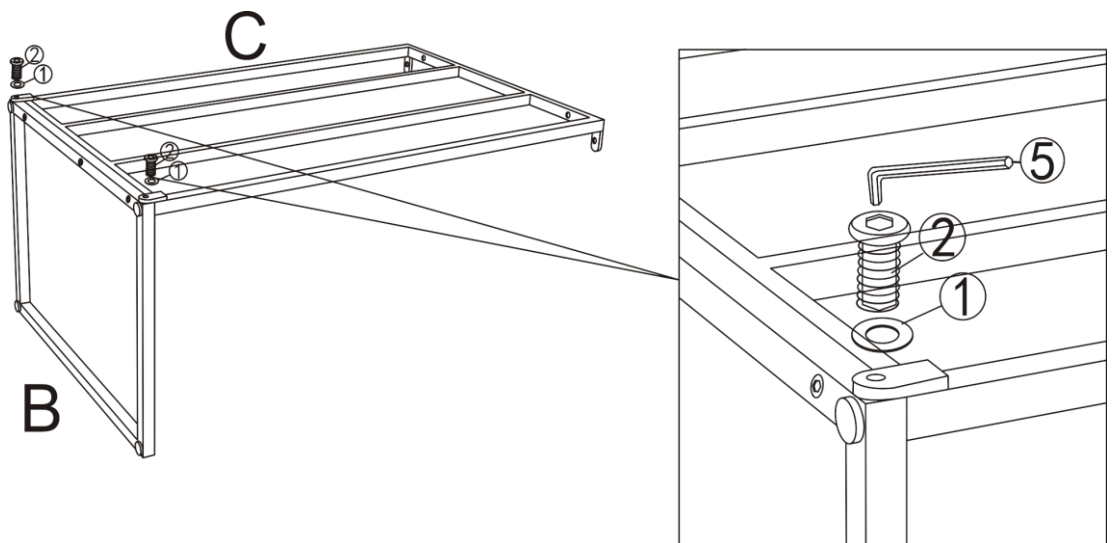

Attach Leg(C) to Support Bar(B) using Washer(①) and Bolt(②) with Allen Wrench(⑤) as shown.
Do not fully tighten the Bolts.

Step 4

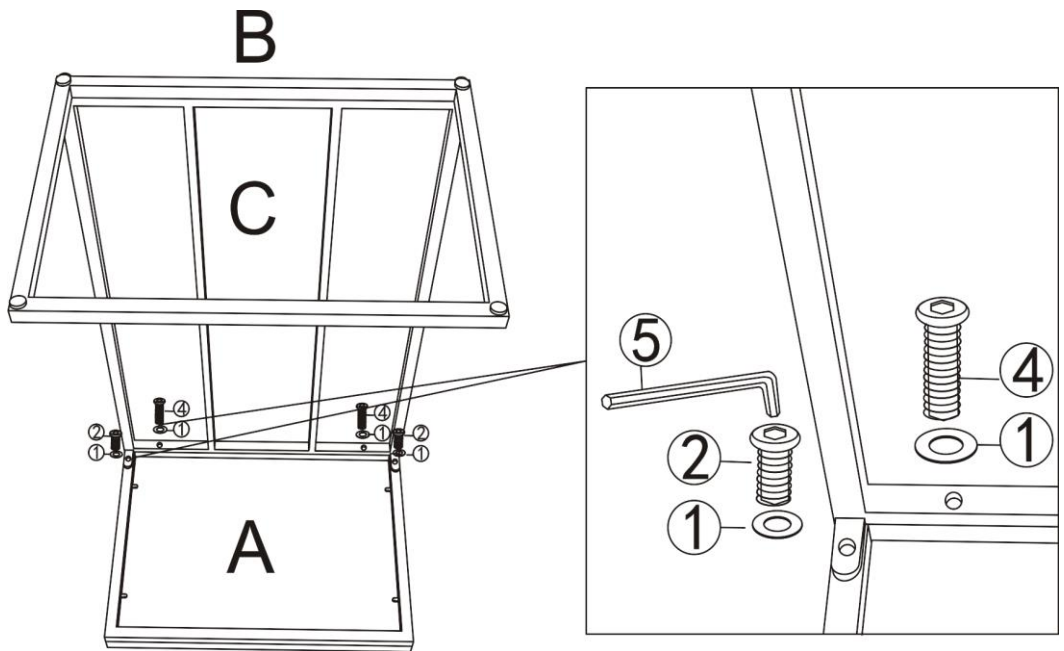





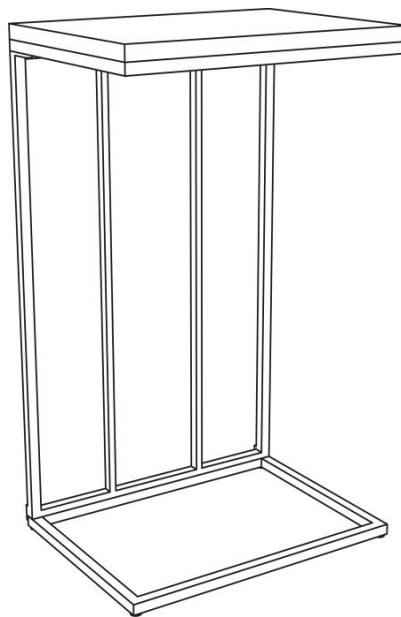















Align the mounting positions on the Table Top(A) and the Leg(C), Attach Leg(C) to Table Top(A) using Washer(①) and Bolt(④) with Allen Wrench(⑤) as shown.

Step 5



In a sequential manner, drive in and fully tighten all Bolts at all joints. Thereafter, turn the Table right side up. Your Table is now ready to for use.

Care & Maintenance

-   • Do not put hot items directly on furniture surface
 -   • Do not clean furniture with harsh cleansers or polish.
 -   • Do not place furniture under direct sunlight.
 -   • Do not place furniture near heating or cooling vents.
 -   • Do not write on furniture without a padded barrier to protect the surface.
 -   • Do not place furniture outside . For indoor use only .
 -   • Not for commercial use. For residential use only .
 -   • Stains may be removed with mild soap solution and damp cloth.
 -   • Children should not climb or jump on the furniture.
-
-   • Dust and pick-up spills using a clean, non-colored, lint-free cloth .