

EN:

**CAUTION:**

- \* Before using the chair, ensure that all screws are fully tightened.
- \* Lubricate all moving parts and retighten all screws every 6 months or as needed.

To remove odor, air the chair outdoors in shade for 1-2 days.



Periodically retighten all screws. Do not use an electric screwdriver.

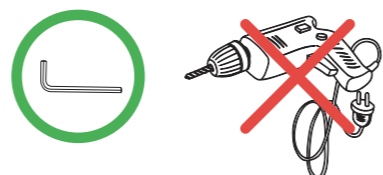

ES:

**PRECAUCIÓN:**

- \* Antes de usar la silla, asegúrese de que todos los tornillos estén bien apretados.
- \* Lubrique las piezas móviles y reapriete todos los tornillos cada 6 meses o cuando sea necesario.

Para eliminar el olor, aeree la silla al aire libre, a la sombra, durante 1-2 días.



Reapriete periódicamente todos los tornillos. No utilice un atornillador eléctrico.

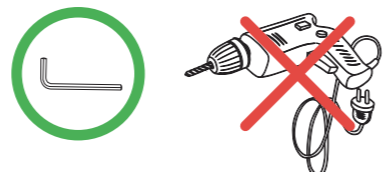

FR:

**ATTENTION :**

- \* Avant d'utiliser la chaise, assurez-vous que tous les vis sont complètement serrés.
- \* Lubrifiez toutes les pièces mobiles et resserrez toutes les vis tous les 6 mois ou selon les besoins.

Pour éliminer les odeurs, aérez la chaise à l'extérieur à l'ombre pendant 1 à 2 jours.



Resserrez périodiquement toutes les vis. N'utilisez pas de tournevis électrique.

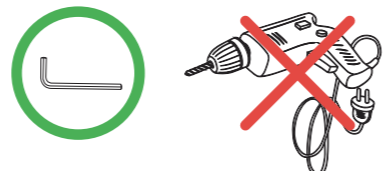

**Safety Information / Información de seguridad / Informations Relatives à la Sécurité**



**INSTRUCTION MANUAL  
MANUAL DE INSTRUCCIONES  
MANUEL D'INSTRUCTIONS**



- |              |             |             |             |             |
|--------------|-------------|-------------|-------------|-------------|
| <b>A</b> ×1  | <b>B</b> ×1 | <b>C</b> ×1 | <b>D</b> ×1 | <b>E</b> ×1 |
|              |             |             |             |             |
| <b>F</b> ×1  | <b>G</b> ×5 | <b>H</b> ×5 |             |             |
|              |             |             |             |             |
| <b>1</b> ×10 | <b>2</b> ×4 | <b>3</b> ×8 | <b>4</b> ×8 | <b>5</b> ×1 |
|              |             |             |             |             |
| M6*14MM      | M6*20MM     | M6*25MM     |             |             |

EN:  : Partially tighten the screws.

 : Fully tighten the screws.

ES:  : Apriete parcialmente los tornillos.

 : Apriete completamente los tornillos.

FR:  : Serrez d'abord les vis partiellement.

 : Serrez les vis complètement.

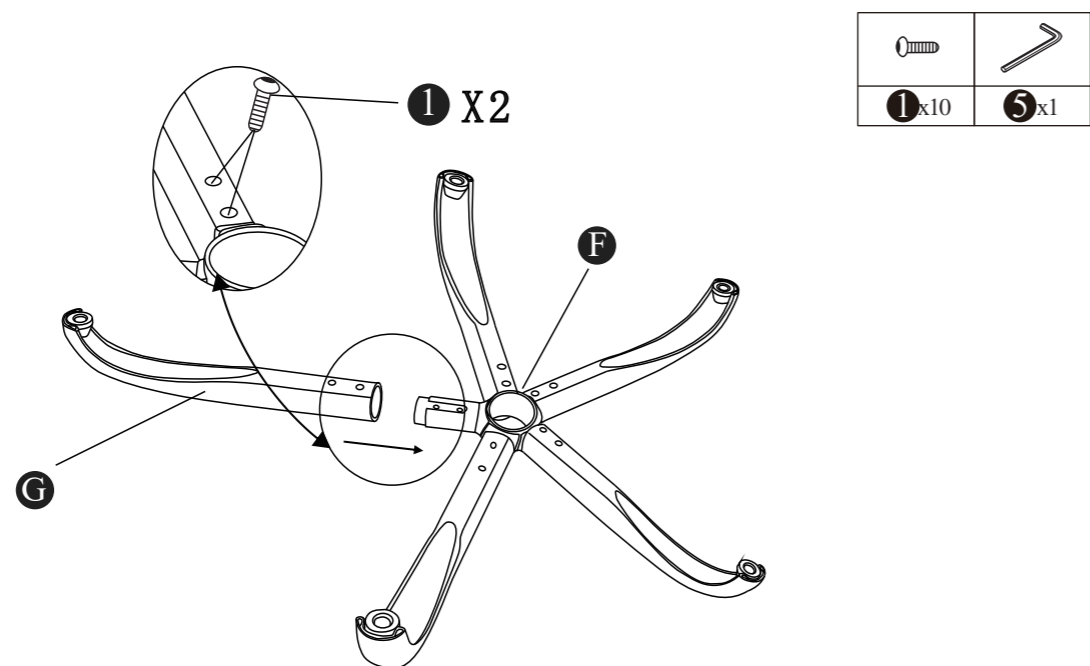

1

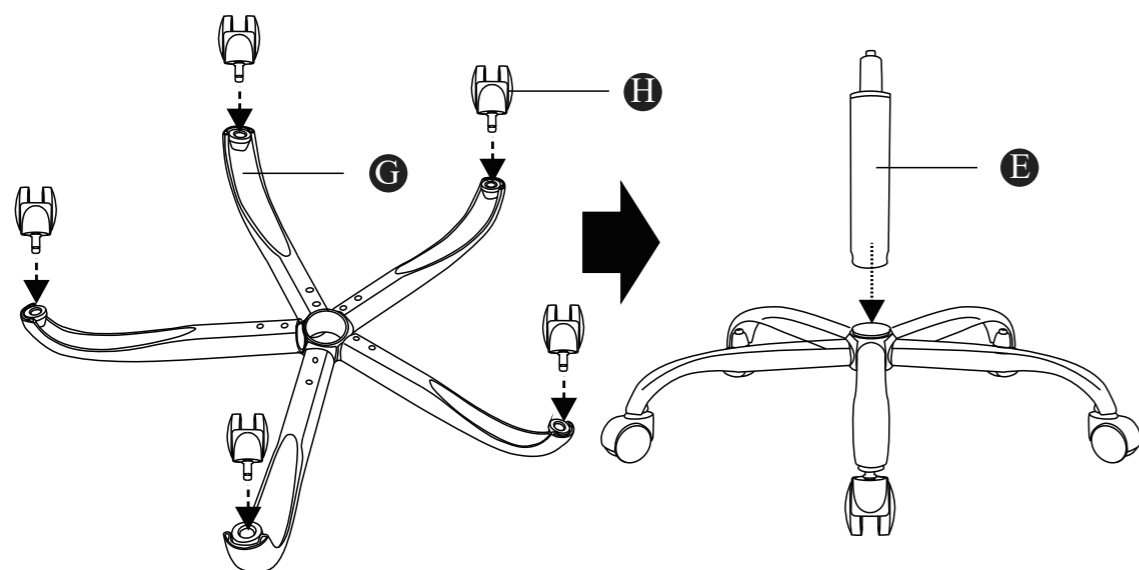

2

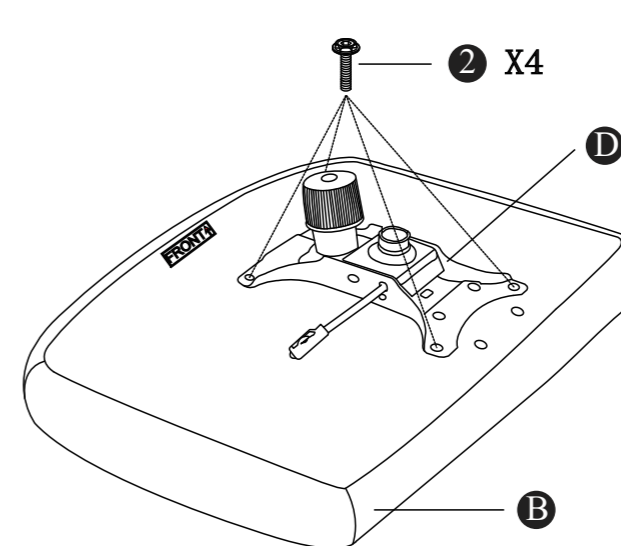

3

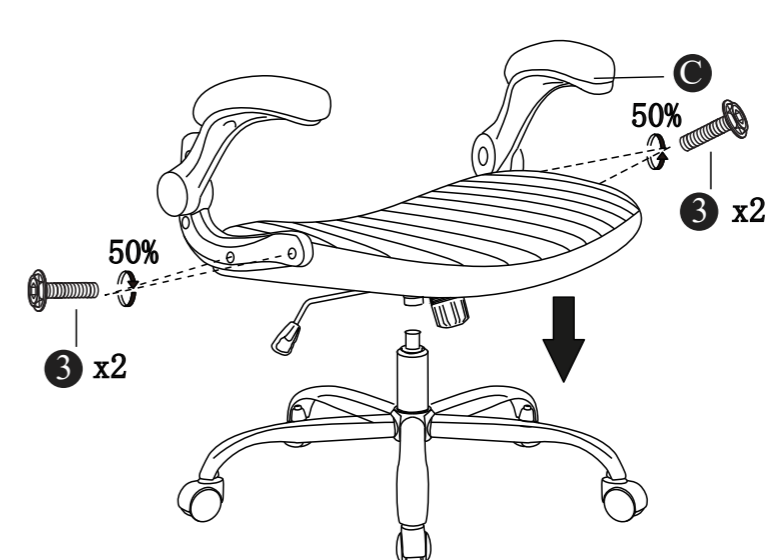

4

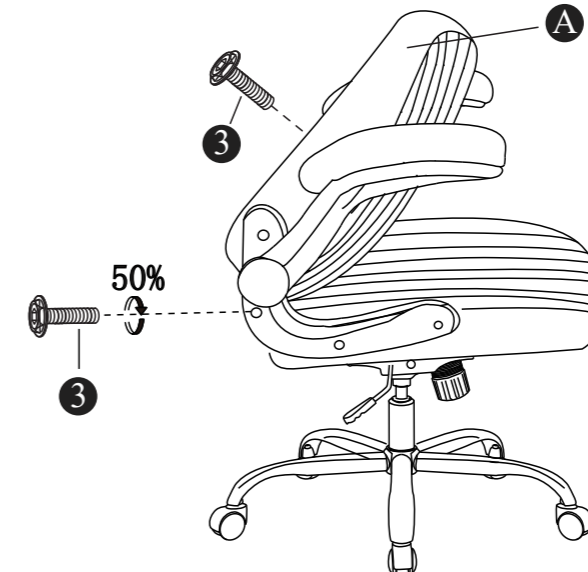

5

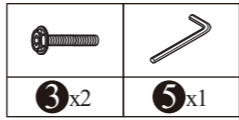
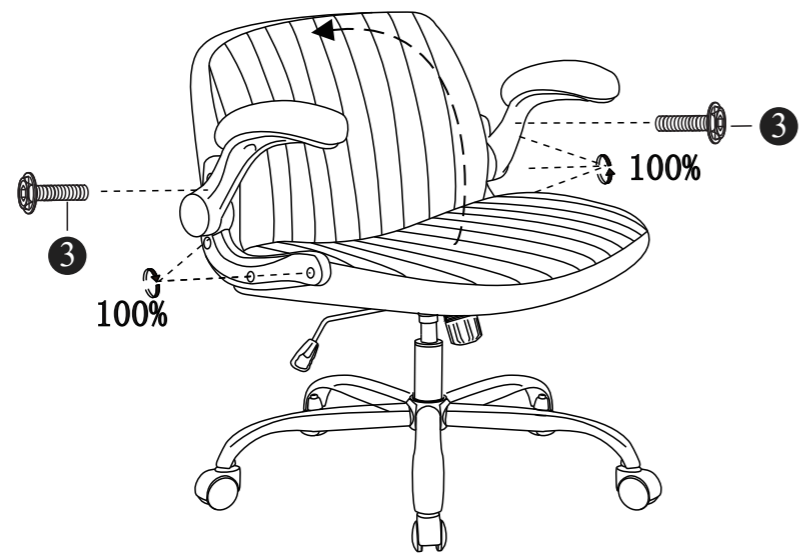
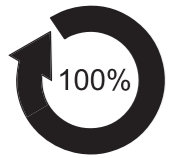

6

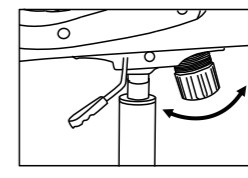
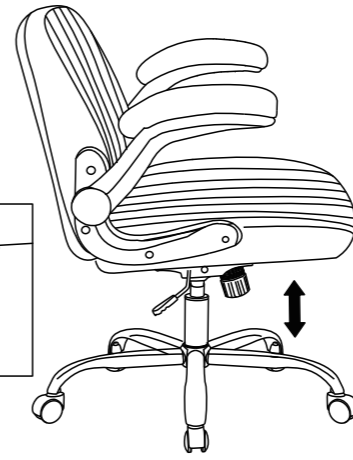
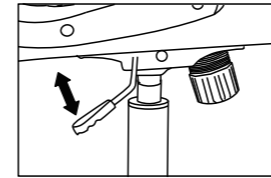

7

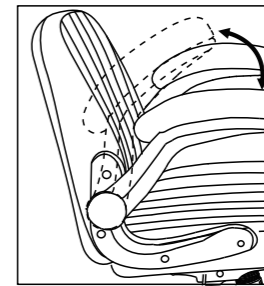
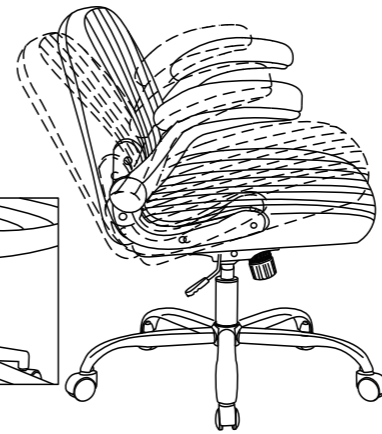
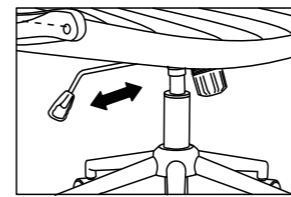
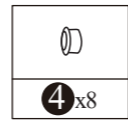
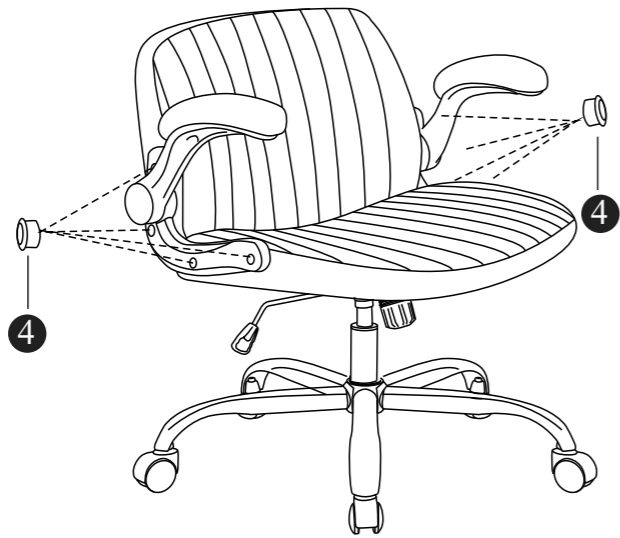

8

