

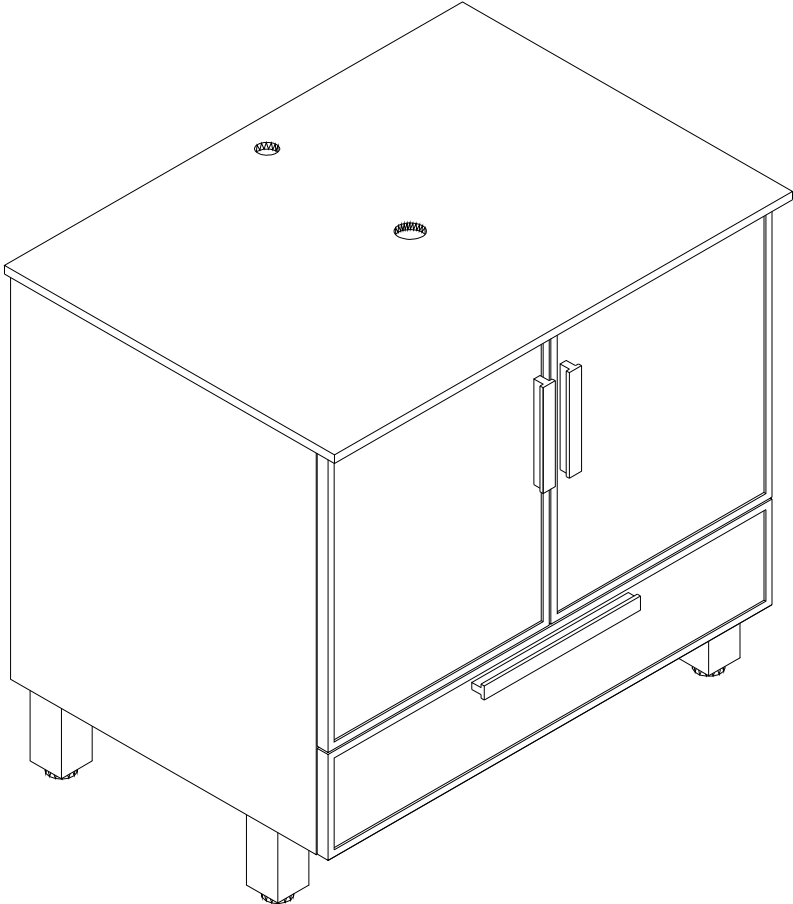

BC033LS  
-QD10-J-FP



# DIMENSIONS





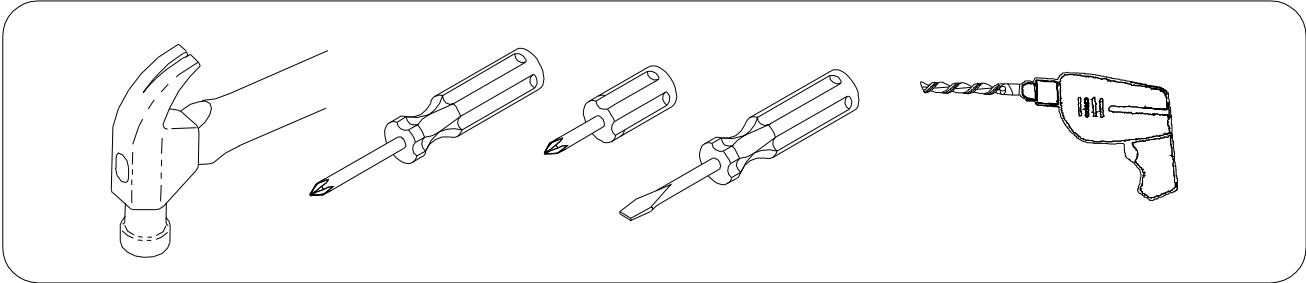



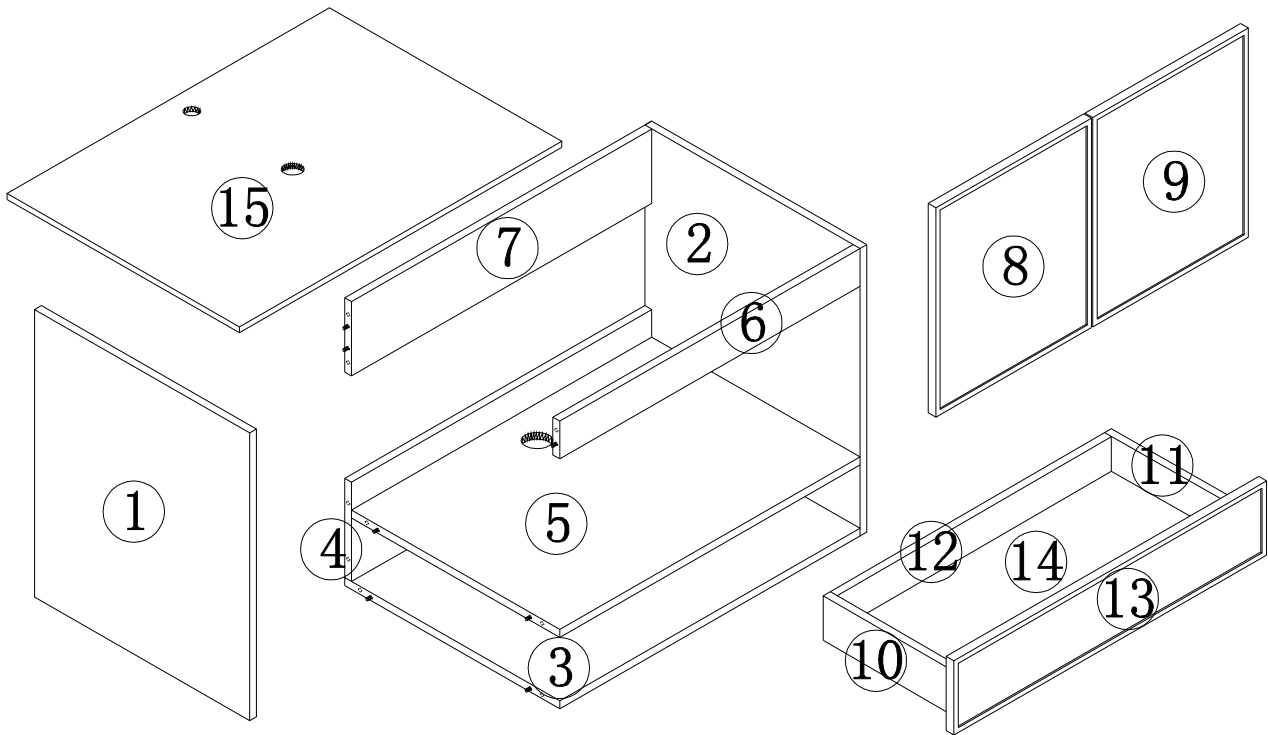









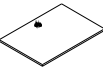

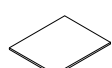





## YOU MAY NEED (NOT SUPPLY)



# ASSEMBLY DIAGRAM

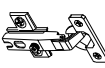

PARTS LIST					
PARTS LIST					
NO	DESCRIPTION	QTY	NO	DESCRIPTION	QTY
①	Left side panel 	1	⑨	Right door panel 	1
②	Right side panel 	1	⑩	drawer left panel 	1
③	Bottom panel 	1	⑪	right side of drawer 	1
④	rear drop down 	1	⑫	drawer back panel 	1
⑤	laminate 	1	⑬	drawer panel 	1
⑥	front pull 	1	⑭	drawer bottom 	1
⑦	rear pull-up bar 	1	⑮	Countertop Panel 	1
⑧	Left door panel 	1			

PARTS LIST					
HARDWARE LIST					
NO	DESCRIPTION	QTY	NO	DESCRIPTION	QTY
A	Three-in-one eccentric wheel 	26	G	Aluminum alloy leg 	4
B	Three-in-one connecting rod 	26	H	4*16mm screw 	48
C	Three-in-one sticker 	26	I	4*20mm screw 	6
D	8*40mm wood dowel pins 	14	J	Door handle 	2
E	Drawer slides 	2	K	Drawer handle 	1
F	Door hinge 	4			
CAUTION: Please confirm the parts list before installation					

# STEP 1

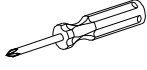
HARDWARE LIST	
Three-in-one connecting rod B 26PCS	

1. Put the three-in-one connecting rod in the 10mm hole of the following panels and tighten them with a cross screwdriver or an electric tool.

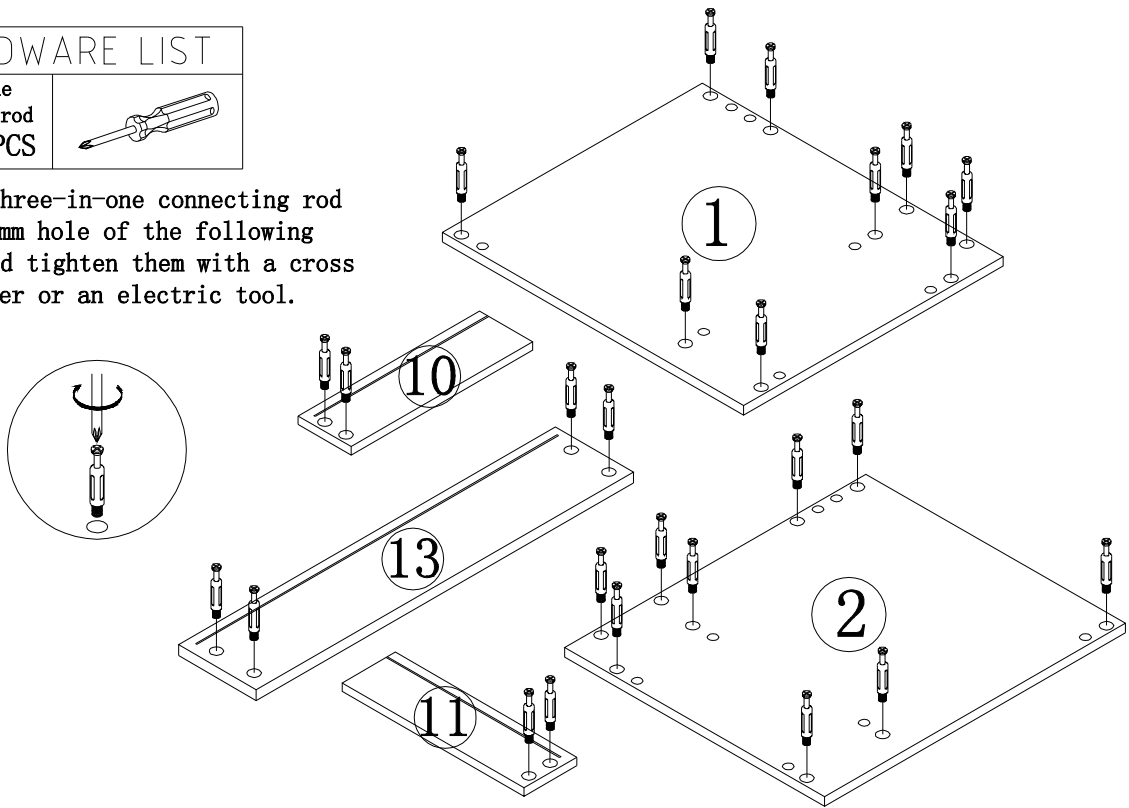

# STEP 2

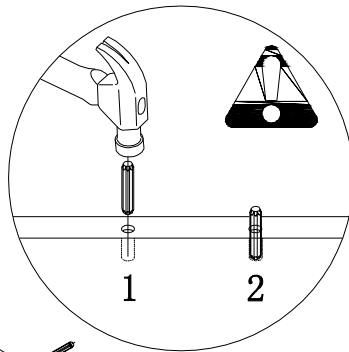

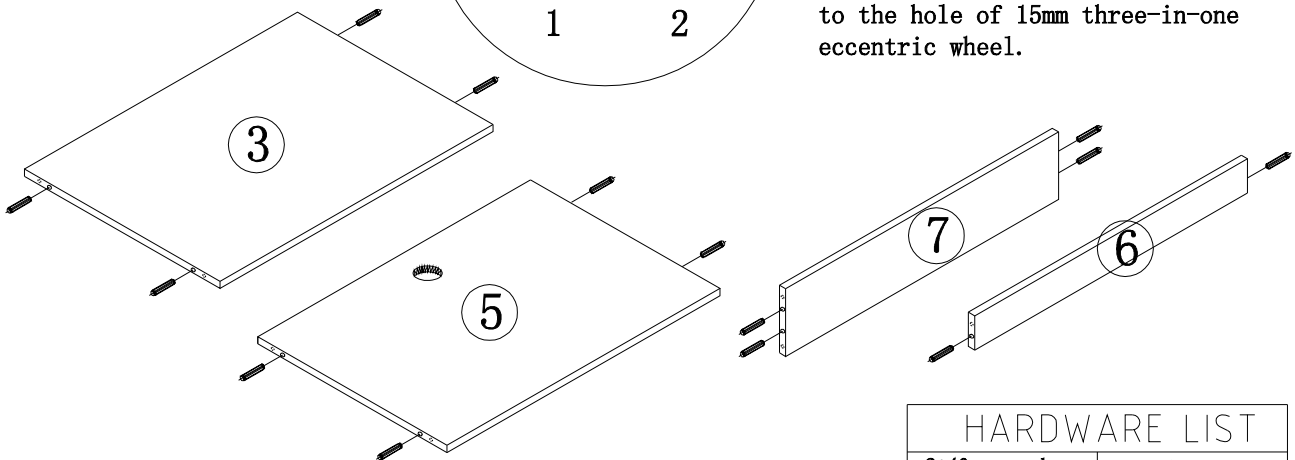

1. Strike the 8\*40mm wood dowel pin into the 8mm hole of the above panels with an iron hammer. Please note that the hole of the wood dowel pins should also be 8mm. The hole of the three-in-one connecting rod connects to the hole of 15mm three-in-one eccentric wheel.

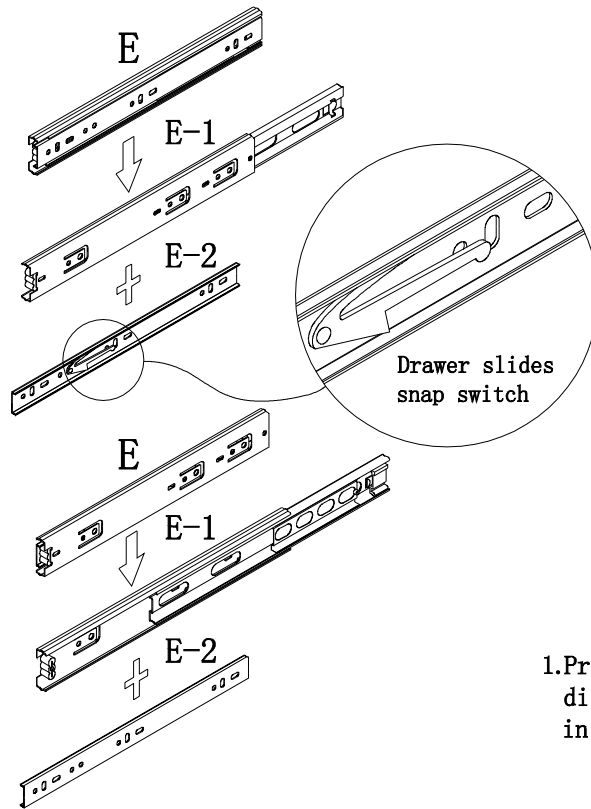

HARDWARE LIST	
8*40mm wood dowel pins D 14PCS	

# STEP 3





HARDWARE LIST	
Drawer slides	
E  2PCS	

1. Press the slide snap switch, disassemble slide blocks and put them in a place properly for further use.

# STEP 4

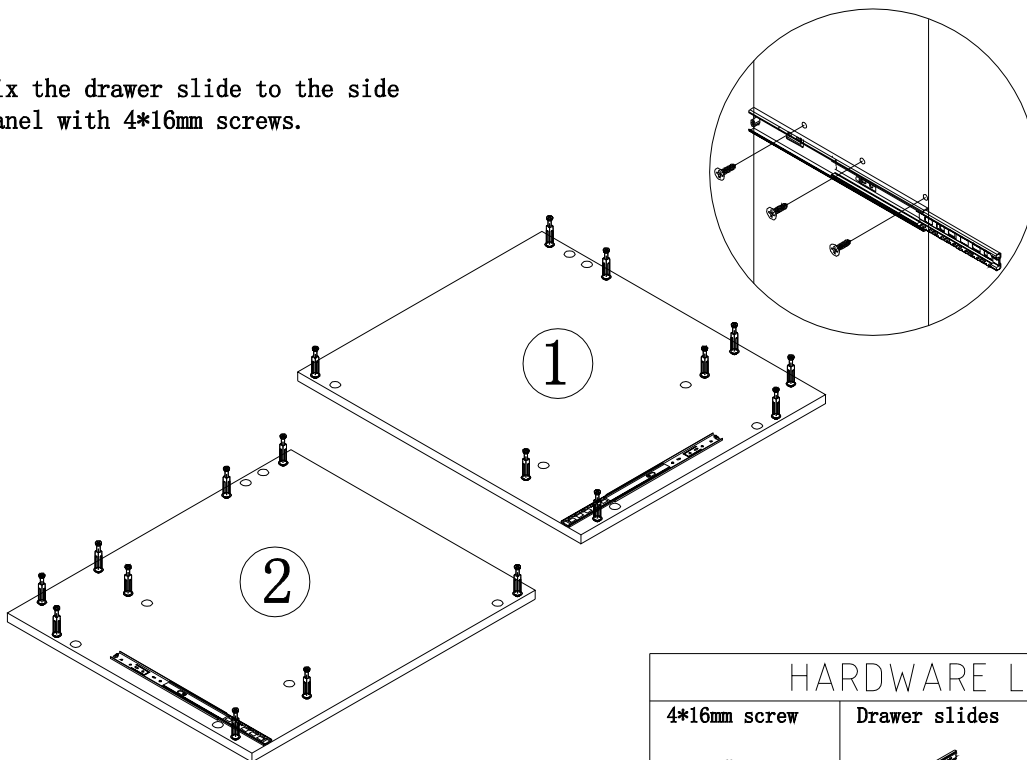
1. Fix the drawer slide to the side panel with 4\*16mm screws.

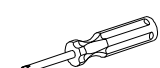

HARDWARE LIST		
4*16mm screw	Drawer slides	
H  6PCS	E-1  2PCS	

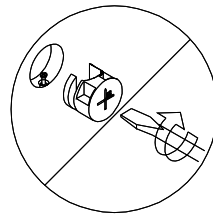
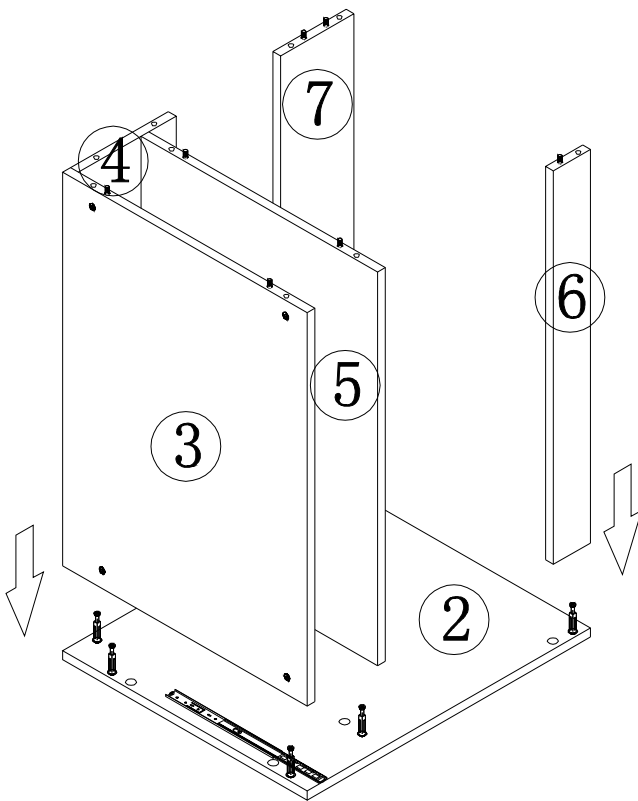

# STEP 5

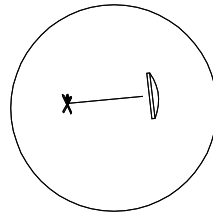

1. Connect No. 3-4-5-6-7 panel to No. 2 panel tightly with the three-in-one eccentric wheel.

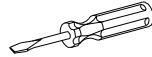

2. Cover the mounting hole of the eccentric wheel with a three-in-one sticker.

HARDWARE LIST		
Three-in-one eccentric wheel A  9PCS	Three-in-one sticker C  9PCS	

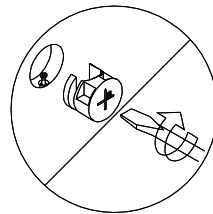
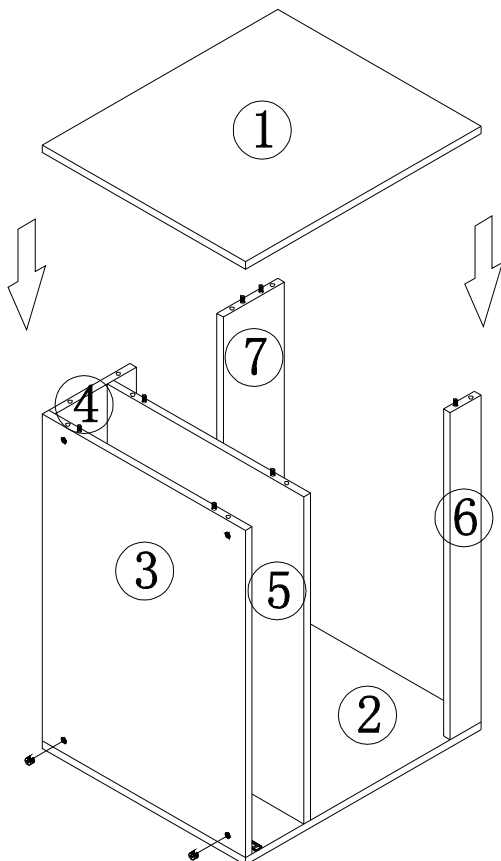

# STEP 6

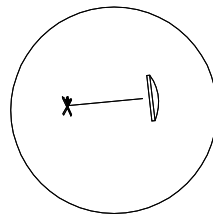

1. Connect No. 1 panel to No. 3-4-5-6-7 panel tightly with the three-in-one eccentric wheel.



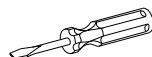

2. Cover the mounting hole of the eccentric wheel with a three-in-one sticker.

HARDWARE LIST		
Three-in-one eccentric wheel A  9PCS	Three-in-one sticker C  9PCS	

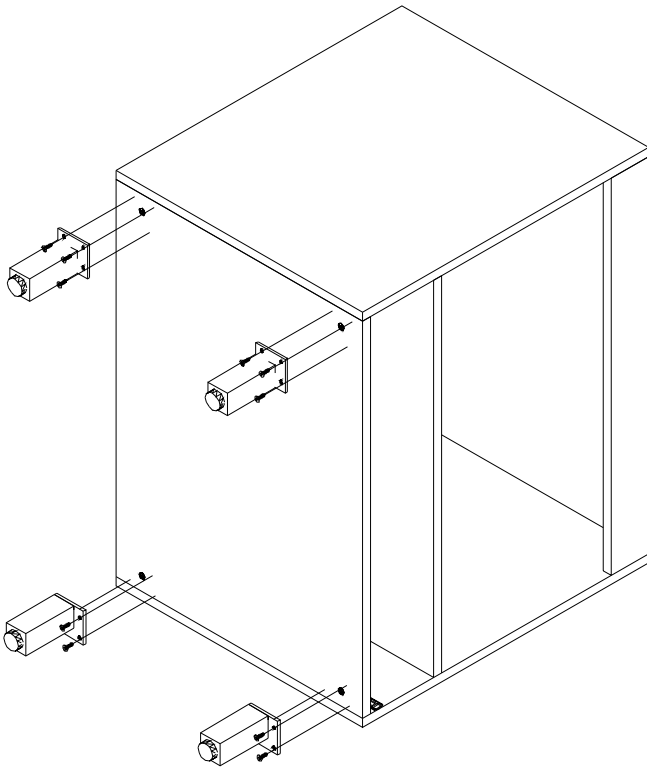
# STEP 7

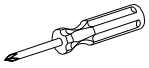

1. Fix feet of the cabinet with 4\*16mm screws.

HARDWARE LIST		
4*16mm screw	Aluminum alloy leg	
H  12PCS	G  4PCS	

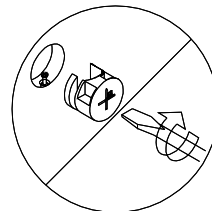
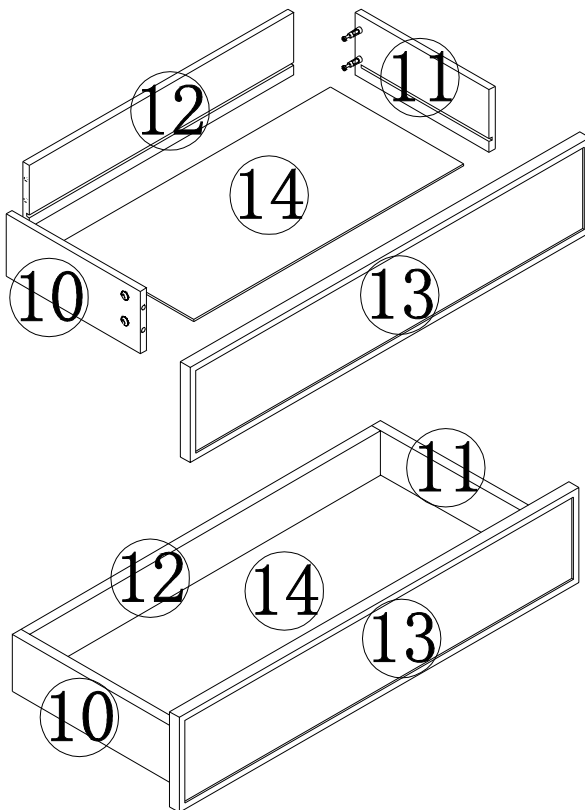

# STEP 8

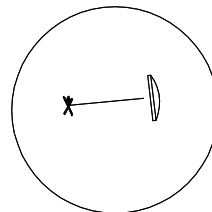

1. Install No. 10-11-12-13-14 panels with the three-in-one eccentric wheel tightly.

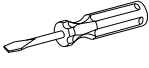

2. Cover the mounting hole of the eccentric wheel with a three-in-one sticker.

HARDWARE LIST		
Three-in-one eccentric wheel	Three-in-one sticker	
A  8PCS	C  8PCS	

# STEP 9

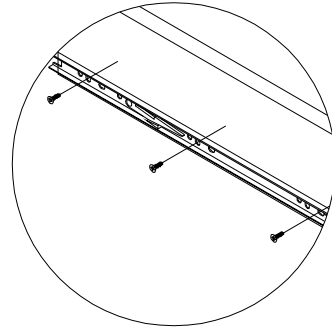
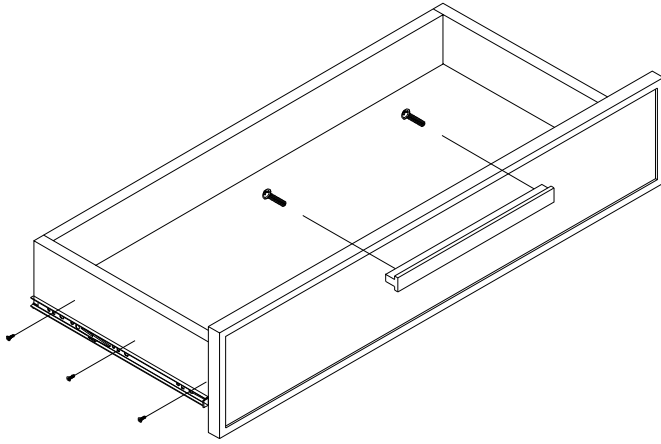

- 1.Lock the spare drawer slide block to the drawer.
- 2.Install the drawer handle with 4\*20 handle screws.

HARDWARE LIST		
4*16mm screw	Drawer slides	
H  6PCS	E-2  2PCS	
4*20mm screw	Drawer handle	
I  2PCS	K  1PCS	

# STEP 10

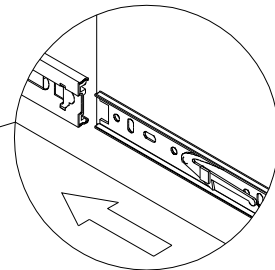
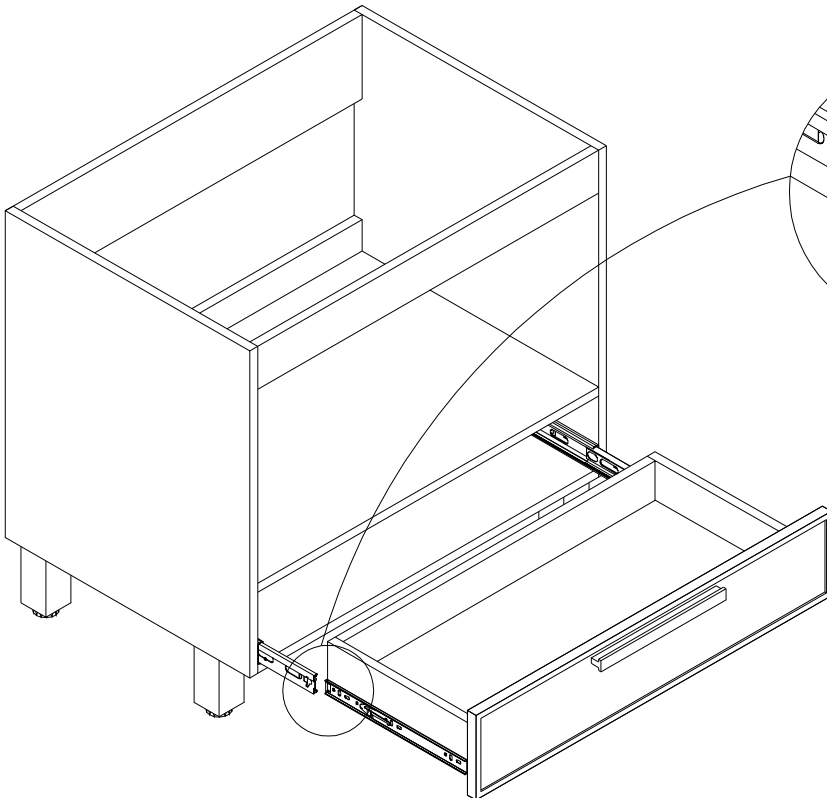

- 1.Align slide block with the trough on the guide rail, press the snap switch and press it forward to install the drawer.
- 2.Install drawer handles.

# STEP 11

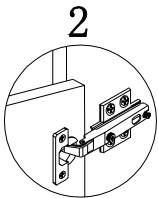
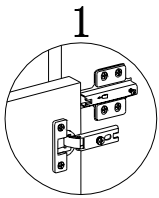
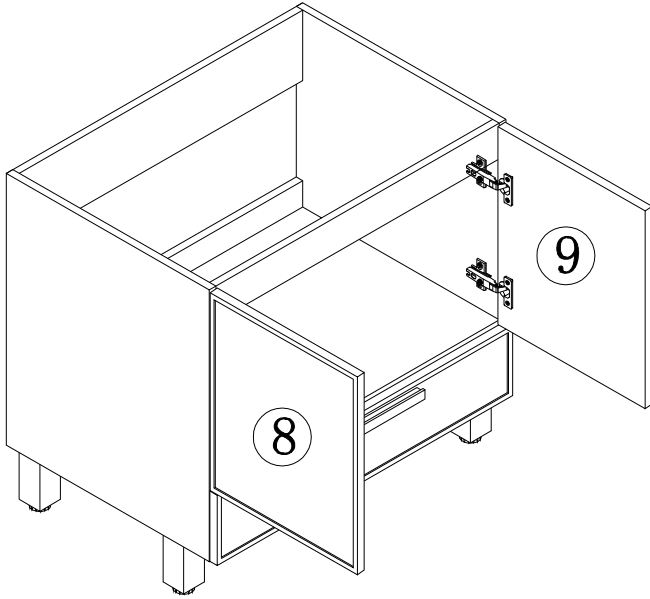

3. Install the hinge cup on the door panel to the hinge of the side panel.

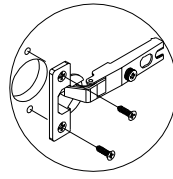

1. Install the hinge cup to the door panel with 4\*16mm screws.

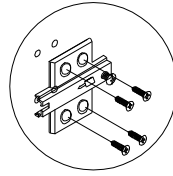

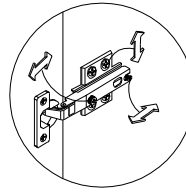

2. Install the hinge to the side panel with 4\*16mm screws.

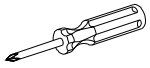

4. Adjust the door panel clearance.

## HARDWARE LIST

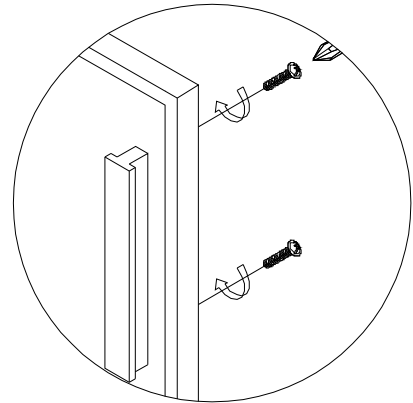
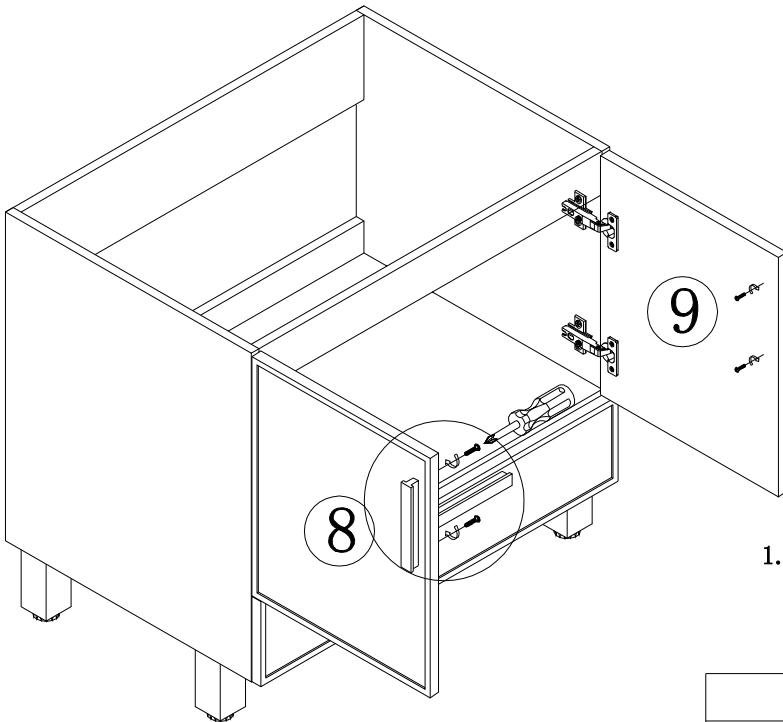

4*16mm screw	Door hinge	
H  24PCS	F  4PCS	

# STEP 12

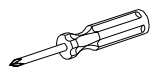

1. Install the door handle with 4\*20 handle screws.

## HARDWARE LIST

4*20mm screw	Door handle	
I  4PCS	J  2PCS	

# STEP 13

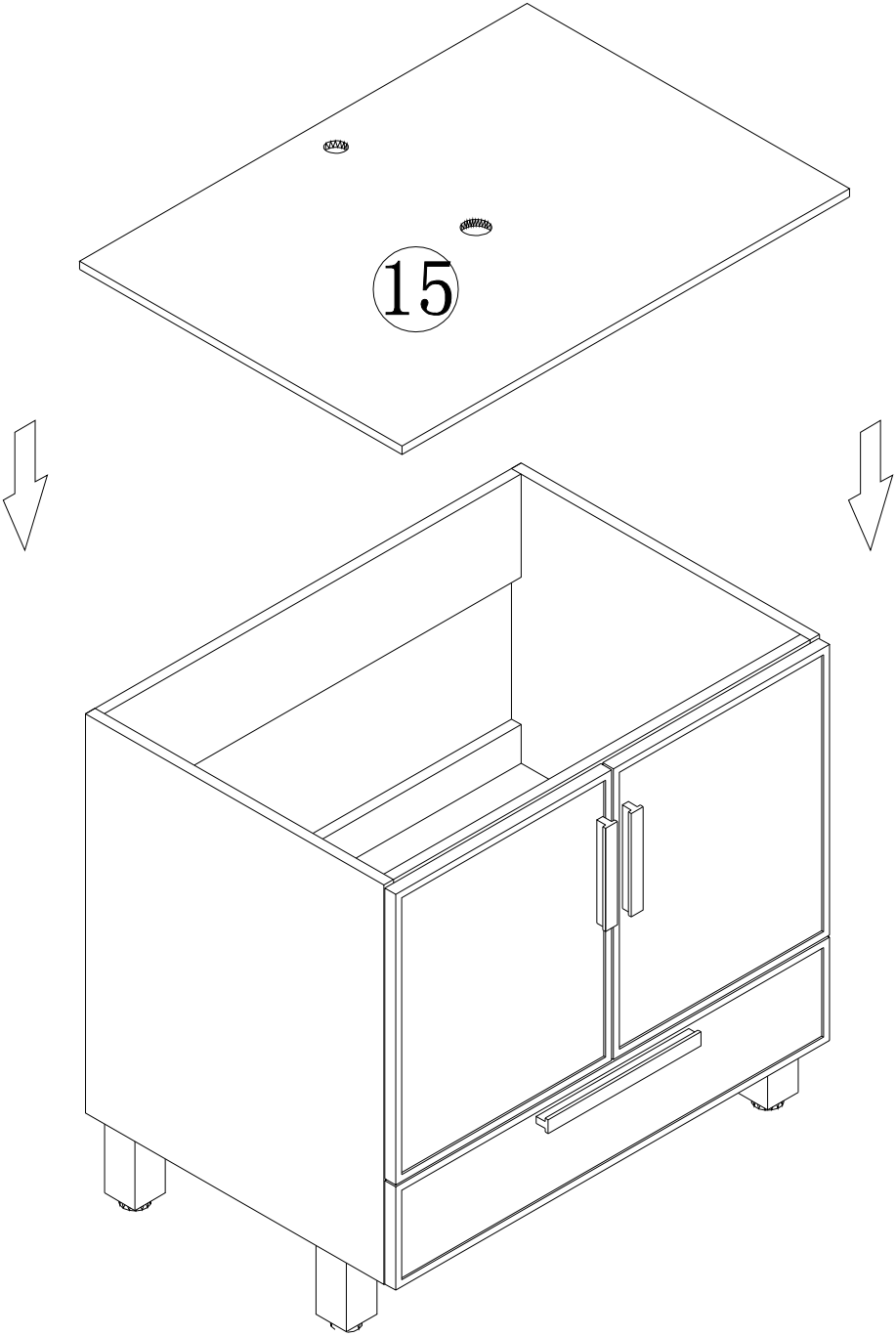

1.Put #15 countertop panel on the top of the cabinet.



**Choking hazard-Small Parts :** This unit contains small parts, not for children under 3 years.

**Tip-over hazard :** Secure finished unit to wall stud using L-Bracket and wall screw (#10\*1.5"W/out provided). If a wall stud is not neccessible , Consault your local hardware store for appropriate mounting hardware . Failure to properly install will result in product collapse or tip-over. Serious injury can occur .