

Murphy bed / Lit escamotable

Assembly Instructions - Please keep for future reference

Instructions d'assemblage - s'il vous plaît garder pour référence future

WF307306, WF307307
WF307308

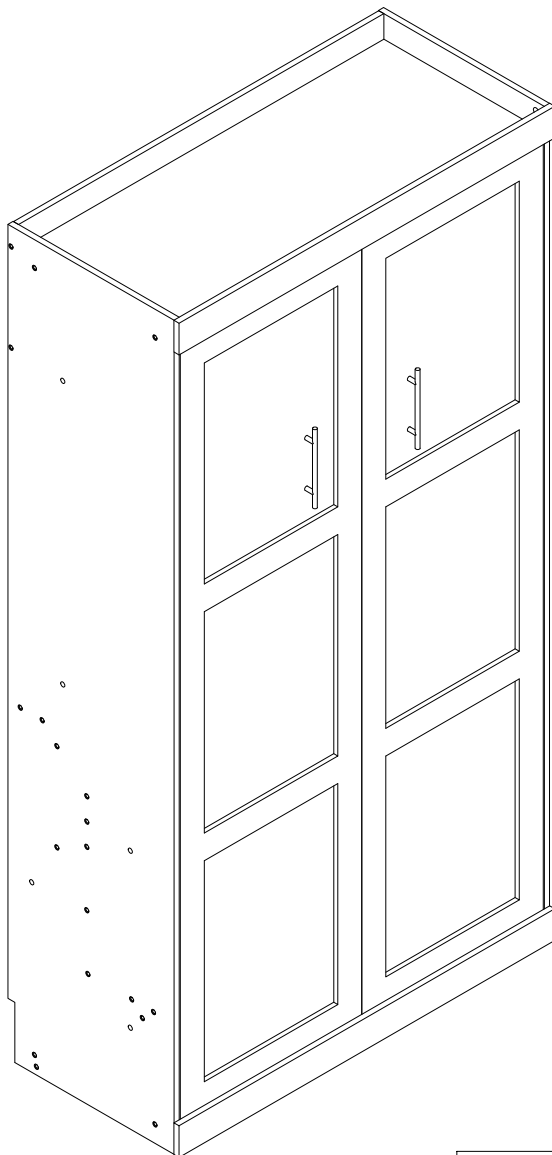

Please scan the QR code to watch the installation video

Veillez scanner le code QR pour Voir la vidéo d'installation



Three people are required to assemble and move this model.
Trois personnes sont nécessaires pour Assembler et déplacer ce modèle.

Important – Please read these instructions fully before starting assembly

Important - veuillez lire ces instructions complètement avant de commencer l'assemblage

Assembly Instructions / Instructions de montage

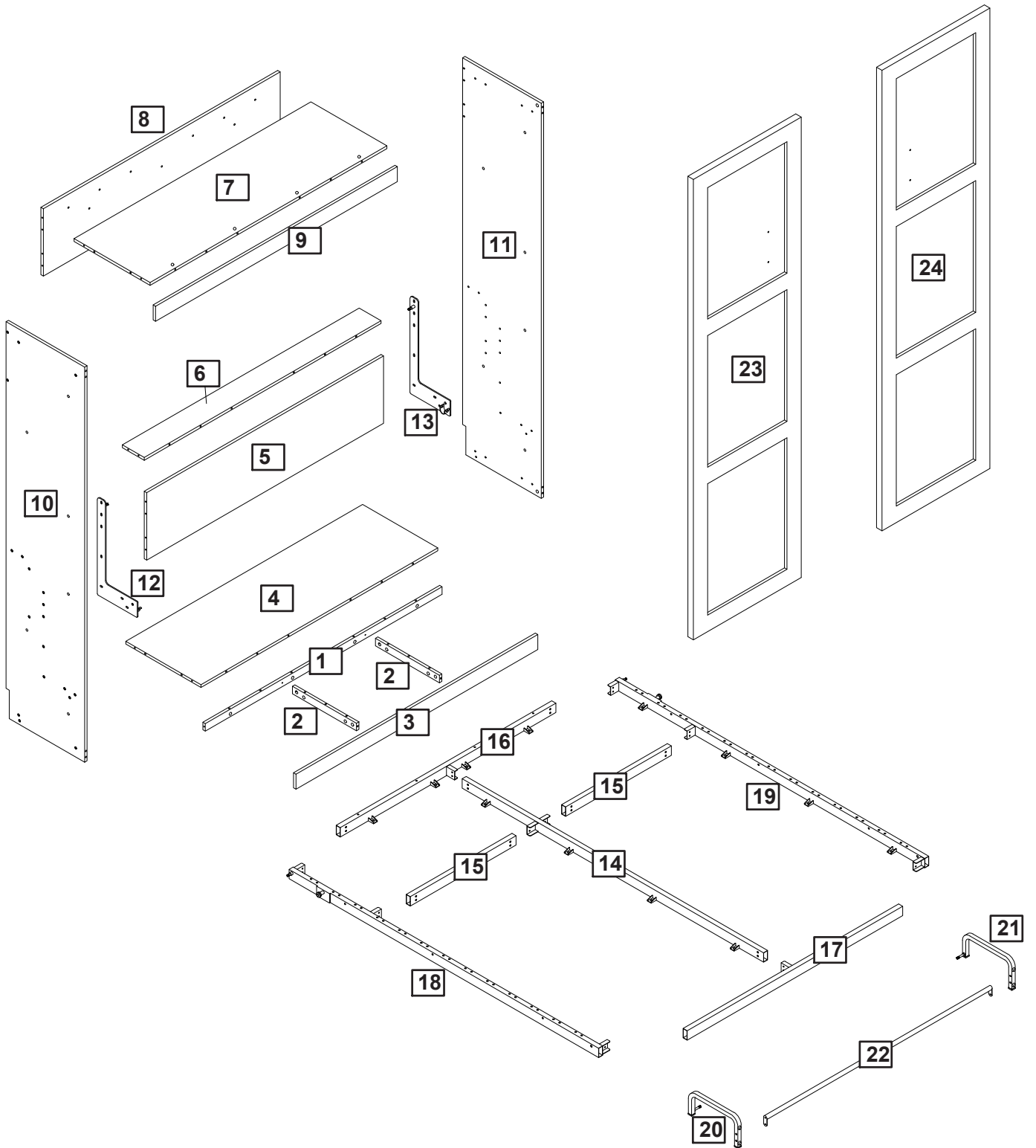





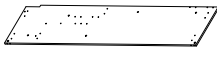
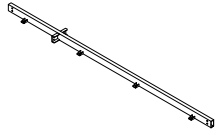
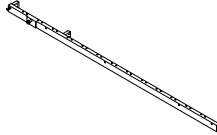
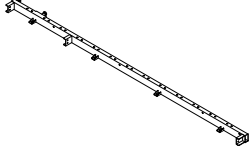
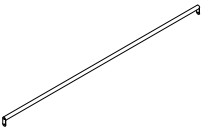
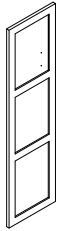
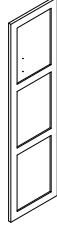
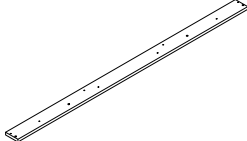
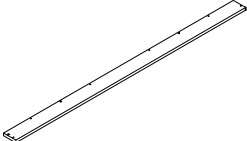

Part List / Liste des pièces

Hardware list / Liste du matériel: WF307306

<p>⑩</p>  <p>1 PC</p>	<p>⑪</p>  <p>1 PC</p>	<p>⑭</p>  <p>1 PC</p>	<p>⑱</p>  <p>1 PC</p>	<p>⑲</p>  <p>1 PC</p>
<p>⑳</p>  <p>1 PC</p>	<p>㉓</p>  <p>1 PC</p>	<p>㉔</p>  <p>1 PC</p>	<p>③</p>  <p>1 PC</p>	<p>⑨</p>  <p>1 PC</p>

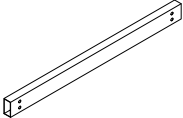
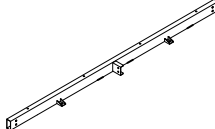
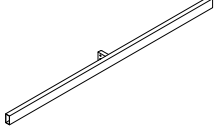
Part List / Liste des pièces

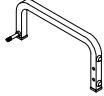
Hardware list / Liste du matériel: WF307307

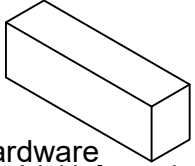
<p>⑫</p>  <p>1 PC</p>	<p>⑬</p>  <p>1 PC</p>	<p>⑮</p>  <p>2 PCS</p>	<p>⑯</p>  <p>1 PC</p>	<p>⑰</p>  <p>1 PC</p>
<p>㉔</p>  <p>1 PC</p>	<p>㉕</p>  <p>1 PC</p>	<p>Ⓢ</p>  <p>2 PCS</p>	<p>ⓧ</p>  <p>13 PCS</p>	<p>Hardware Matériel informatique</p>  <p>1 PC</p>

Part List / Liste des pièces

Hardware list / Liste du matériel: WF307308

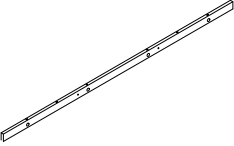
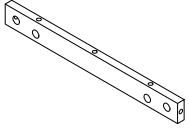
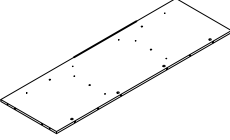
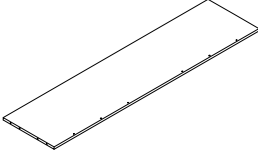
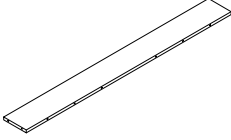
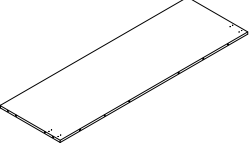
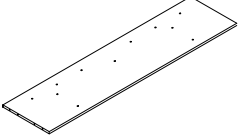
<p>①</p>  <p>1 PC</p>	<p>②</p>  <p>2 PCS</p>	<p>④</p>  <p>1 PC</p>	<p>⑤</p>  <p>1 PC</p>	<p>⑥</p>  <p>1 PC</p>
<p>⑦</p>  <p>1 PC</p>	<p>⑧</p>  <p>1 PC</p>			

Using Camlocks

Step 1

Connect the male camlock as directed in the assembly instructions using a screwdriver.

1

DO NOT OVER TIGHTEN.
NE PAS SERRER EXCESSIVEMENT.

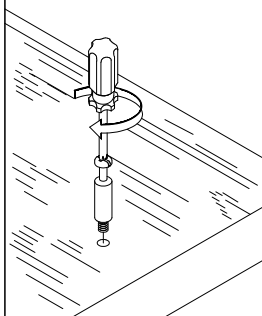

Step 2

Push the male camlock into the entry hole.

2

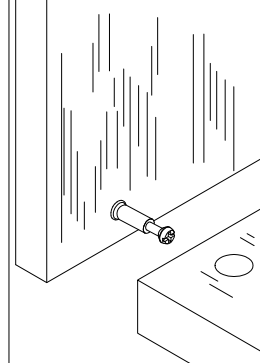

Step 3

Insert the female camlock as shown in the instruction.

Note: ensure that the arrow on the top of the camlock points towards the entry hole for the male camlock.

3

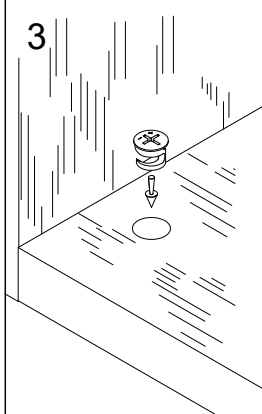

Step 4

Turn the female camlock clockwise with a screwdriver.

You should feel a click when the camlock is locked in place.

The joint is now secure.

4

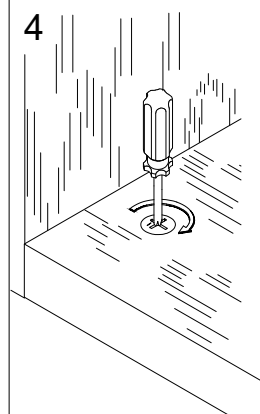

Important information to read before starting the assembly. Keep this information for future reference.

IMPORTANT WARNINGS

Risk of serious injuries if the wall bed tips over.

To prevent wall bed from tipping over, mount it permanently to the wall.

Only a qualified person* must carry out the installation and any possible adjustment of the wall bed (including disassembly). If the wall bed is not firmly mounted (anchored) to the wall, it might tip over and cause serious injuries to the installer, users of the bed as well as the people near the bed.

The choice of wall anchoring depends on the type of wall. Use wall anchors suitable for the wall material.



* Qualified person: it is necessary to have a good understanding of the wall structure where the bed is anchored, including the positioning of the wall studs and structural components in the case of a wood or metal structure. If you do not have the necessary skills, make sure that the installation is done by someone who has the qualifications and required knowledge. When you choose the installer, make sure to comply with all applicable regulations in the province, state or country where the furniture is installed.

IMPORTANT: BEFORE STARTING ASSEMBLY

Be sure to confirm the following information:

1. The installer has the qualifications * and required knowledge.
2. Only wall anchor screws for wood-frame walls are provided with this bed. See anchor requirements and installation notes provided in the instruction manual, according to the type of wall, and use the appropriate anchors such as described in this manual.
3. Your bed can hold a maximum distributed weight of 800 lb (362 kg), including the weight of the mattress.
4. Maximum thickness of mattress: 10 in , and must stand in vertical position without sagging.
5. The bed will not stay open without the weight of the mattress which must be between: 38 lbs (15 kg) and 90 lbs (41 kg).
6. Minimum ceiling height requirements for installation: 83 in (2.11 m).
7. It is recommended to assess the structural integrity of the floor and wall and to make sure that the wall anchoring devices can withstand the forces generated. More specifically, before installing the wall bed, it is necessary to verify that the floor and the wall on which you want to install the bed are flat and have no structural damage that could affect the installation of the wall bed or its anchoring to the wall. Do not install the bed on weakened or rotten structures.
8. It is necessary to ensure that wall anchors of the bed can withstand forces generated. The value of the holding power (Fh) of each anchor should be 630 Newtons (142 lbf).

If the wall bed is not installed properly, the latter might close unexpectedly or could open involuntarily. In addition, if the wall bed is installed incorrectly, one of its structural components may break and fall off.

Utilisation de Camlocks

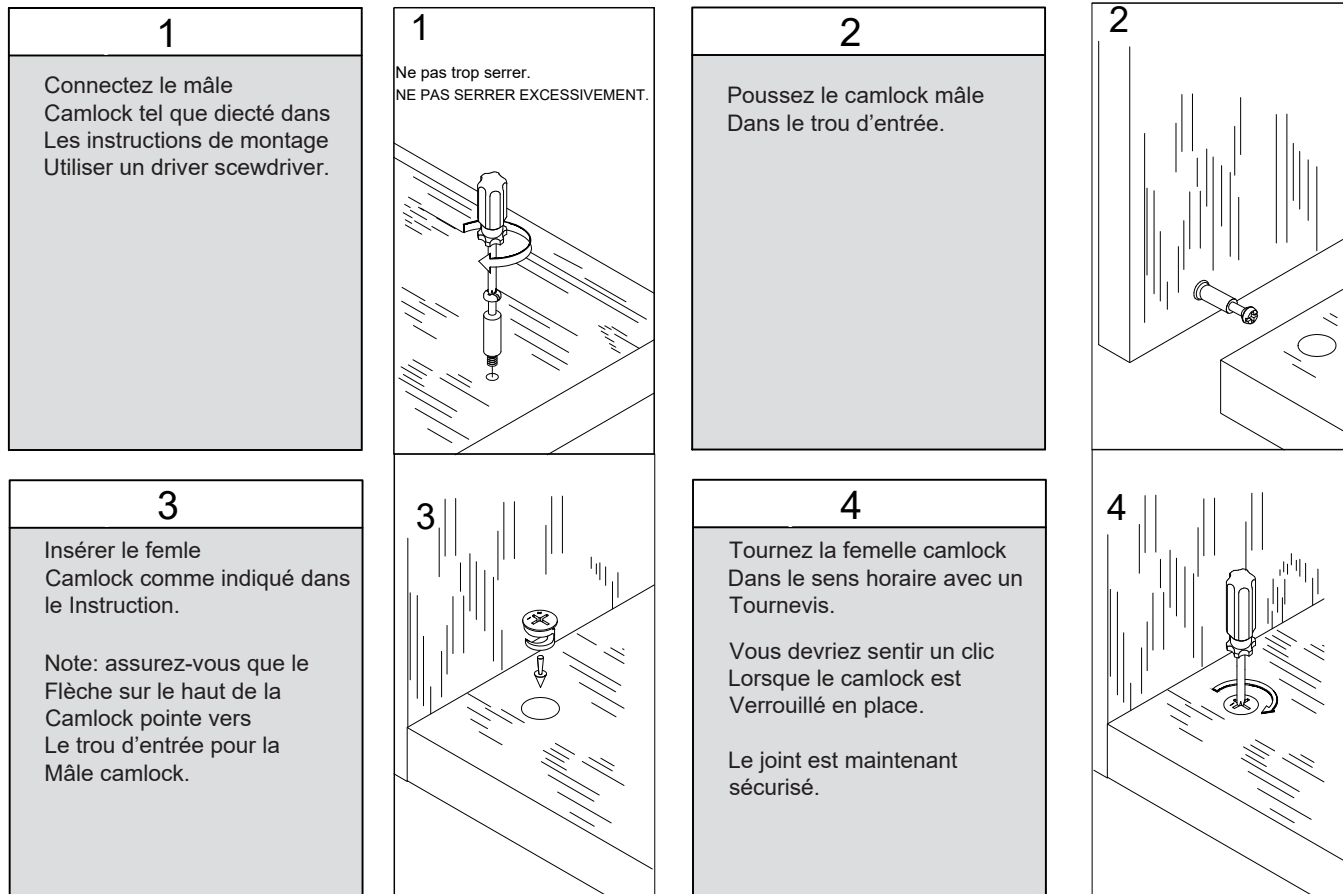

Informations importantes à lire avant le début de l'assemblée.

Conservez cette information pour référence future.

Avertissements importants

Risque de blessures graves si le lit mural se renverse.

Pour empêcher le lit mural de basculer, montez-le en permanence au mur.

Seule une personne qualifiée * doit effectuer l'installation et tout ajustement éventuel du lit mural

(y compris démontage). Si le lit de mur n'est pas solidement monté (ancré) au wal, il peut se basculer

Et causer des blessures graves à l'installateur, aux utilisateurs du lit ainsi qu'aux personnes près du lit.

Le choix de l'ancrage mural dépend du type de mur. Utilisez des ancrages muraux adaptés au matériau du mur.



*personne qualifiée: il est nécessaire d'avoir une bonne compréhension de la structure du mur où le lit est ancré, y compris le positionnement des goujons de mur Fabrication dans laquelle la valeur de toutes les matières utilisées ne doit pas excéder 40 % du prix départ usine du produit Vous ne possédez pas les compétences nécessaires. Mak2 s'assurer que l'installation est effectuée par une personne possédant les qualifications et les connaissances requises. Lorsque vous choisissez l'installateur, assurez-vous de vous conformer à toutes les réglementations applicables dans la province, l'état ou le pays où la fumiture est installée.

IMPORTANT: avant de commencer l'assemblage

Assurez-vous de confirmer les informations suivantes:

1. L'installateur possède les qualifications * et les connaissances requises.

2. Seules les vis d'ancrage pour les murs à ossature en bois sont fournies avec ce lit. Voir les exigences en matière d'ancrage et les notes d'introduction fournies dans le manuel d'instructions, selon le type de wal, et utiliser les ancrages appropriés telles que décrites dans le présent manuel.

3. Votre lit peut contenir un poids réparti maximum de 800 lb (362 kg), y compris le poids du matelas

4. Épaisseur maximale du matelas: 10 po, et doit se tenir en position verticale sans fléchir.

5. Le lit ne restera pas ouvert sans le poids du matelas qui doit être compris entre: 38 lb (15 kg) et 90 lb (41 kg).

6. Hauteur minimale de plafond requise pour l'installation: 83 po (2,11 m).

7. Il est recommandé d'évaluer l'intégralité structurelle du foor et du wal et de s'assurer que les dispositifs d'ancrage muraux peuvent résister aux forces générées. Plus précisément, avant d'installer le lit mural, il est nécessaire de vérifier que le lit et le mur sur lequel vous souhaitez installer le lit sont plats et ne présentent aucun dommage structurel qui pourrait affecter l'installation du lit mural ou son ancrage à la wal. Ne pas installer les structures affaiblies ou pourries bedon.













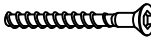
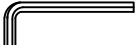





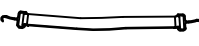

8. Il est nécessaire de s'assurer que les ancrages muraux du lit peuvent résister aux forces générées. La valeur du pouvoir de maintien (Fh) de chaque ancre devrait be 630 Newtons (142 LBF).

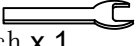
Si le lit mural n'est pas installé correctement, ce dernier peut se fermer inopinément ou peut s'ouvrir involontairement.

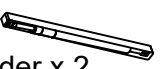
En outre, si le lit mural est mal installé, l'un de ses composants structurels peut se briser et tomber.

Part List / Liste des pièces

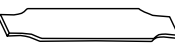
Hardware list / Liste du matériel: WF307307

A  Male Camlock x 28 Mâle Camlock	B  Female Camlock x 28 Femelle Camlock	C  Dowel x 32 Le goujon
D  6*50mm Screw x 26 6*50mm vis	E  Hex Key M4 x 1 Clé hexagonale M4	F  Magnetic bump x 2 Bosse magnétique
G  Expansion screw x 6 Vis d'expansion	H  MATTRESS SUPPORT x 2 SUPPORT de matelas	I  Handle & Fixings x 2 Poignée & fixations
J  Fastener x 2 attache	K  Nut M5 x 2 Ecrou M5	L  Ø20 Sticker x 48 Ø20 autocollant
M  Webbing x 2 Sangle de sangle	N  Nylon washer (19*1.5) x 20 Rondelle en Nylon (19*1.5)	O  Nut M8 x 6 Ecrou M8
P  Wrench x 1 Clé à clé	Q  6*30mm Screw x 4 6*30mm vis	R  5*15mm Screw x 2 5*15mm vis
S  Cylinder x 2	T  6*12mm Screw x 40 6*12mm vis	U  8*20mm Screw x 16 8*20mm vis
V  Hex Key M5 x 1 Clé hexagonale M5	W  Single plastic cap x 26 Capuchon en plastique unique	X  Slat x 13 Les lamelles
Y  Fixed cylinder metal x 2 Cylindre fixe métal		



Assembly Tools Required (Not Included)
 Outils d'assemblage requis (Non Inclus)

Assembly Instructions / Instructions de montage

Step 1

Étape 1

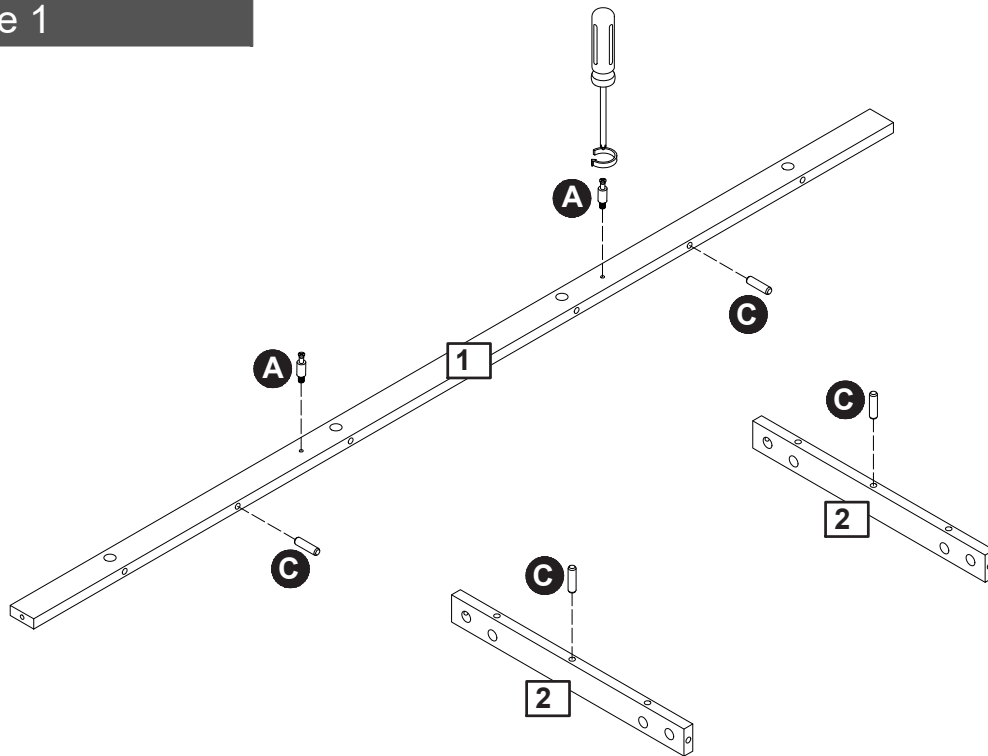

A



A x 2

C



C x 4

Step 2

Étape 2

B



B x 2

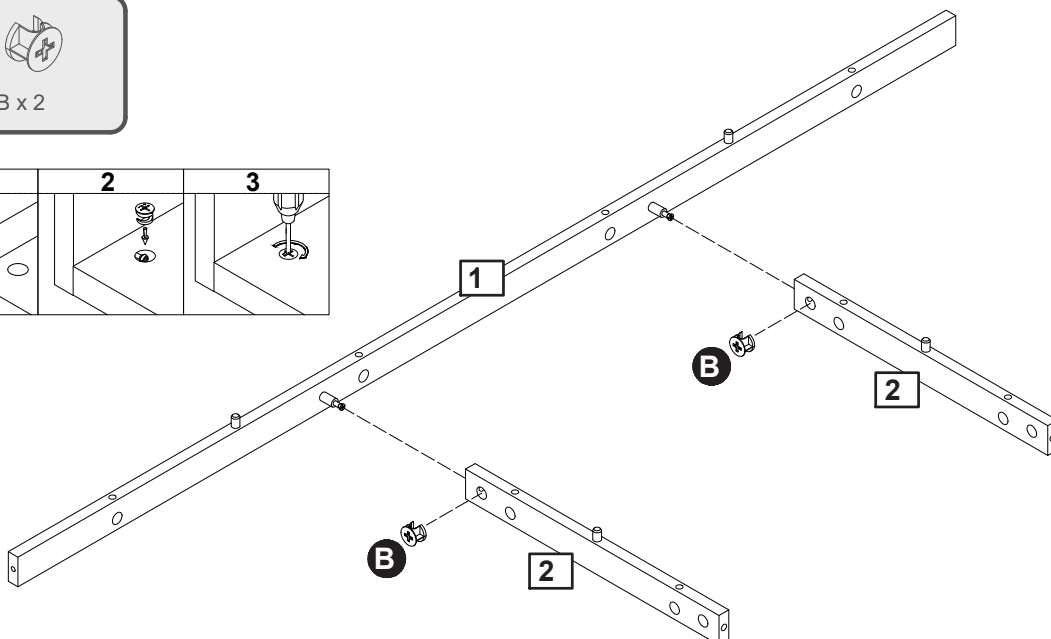
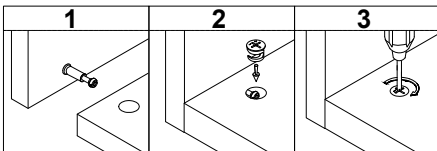

Assembly Instructions / Instructions de montage

Step 3

Étape 3

A



A x 8

C



C x 6

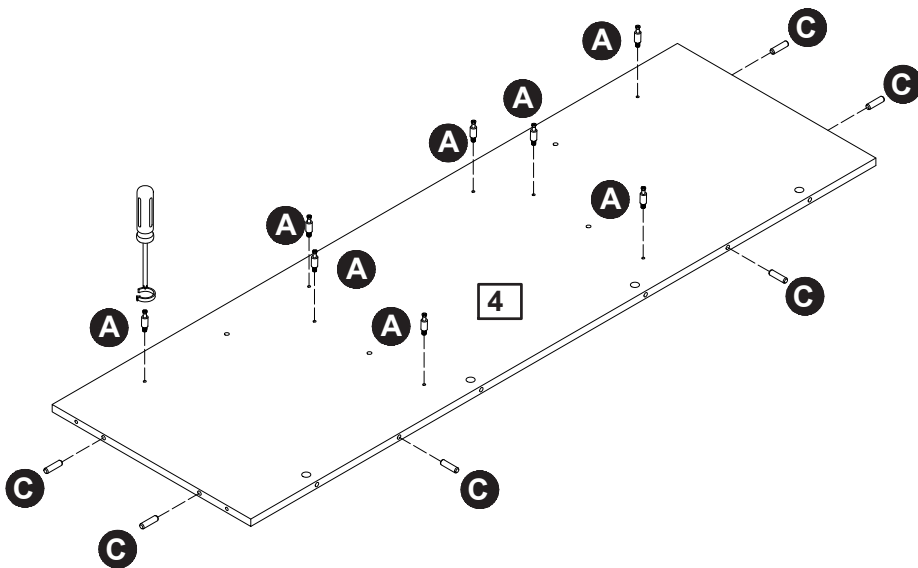

Step 4

Étape 4

A



A x 4

C



C x 6

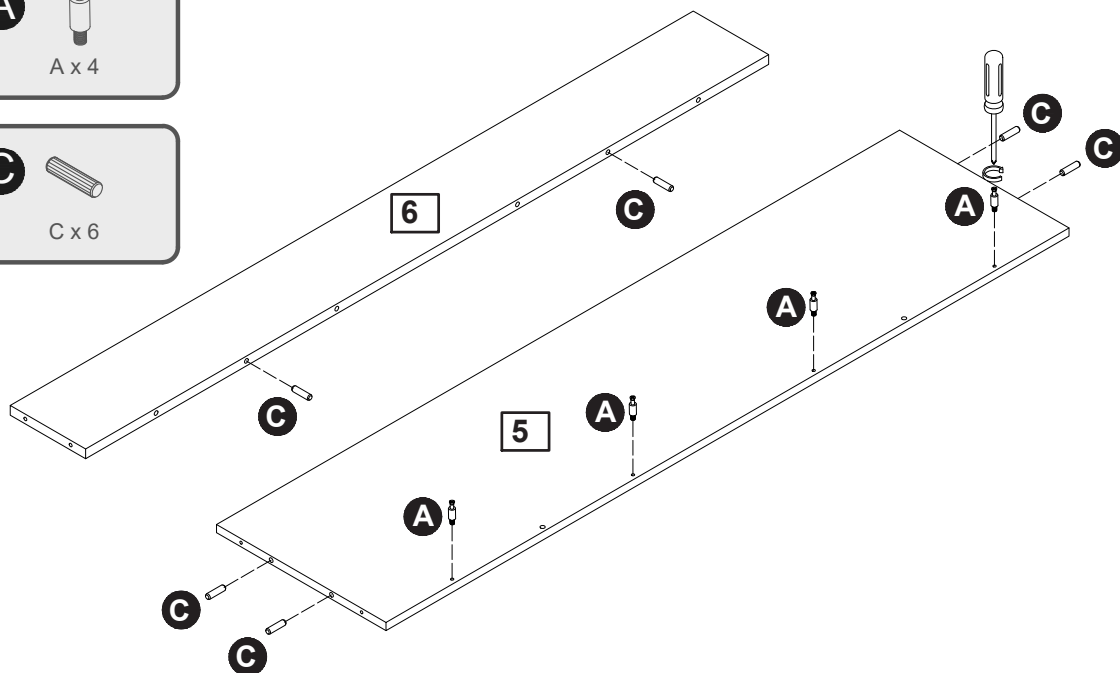

Assembly Instructions / Instructions de montage

Step 5

Étape 5

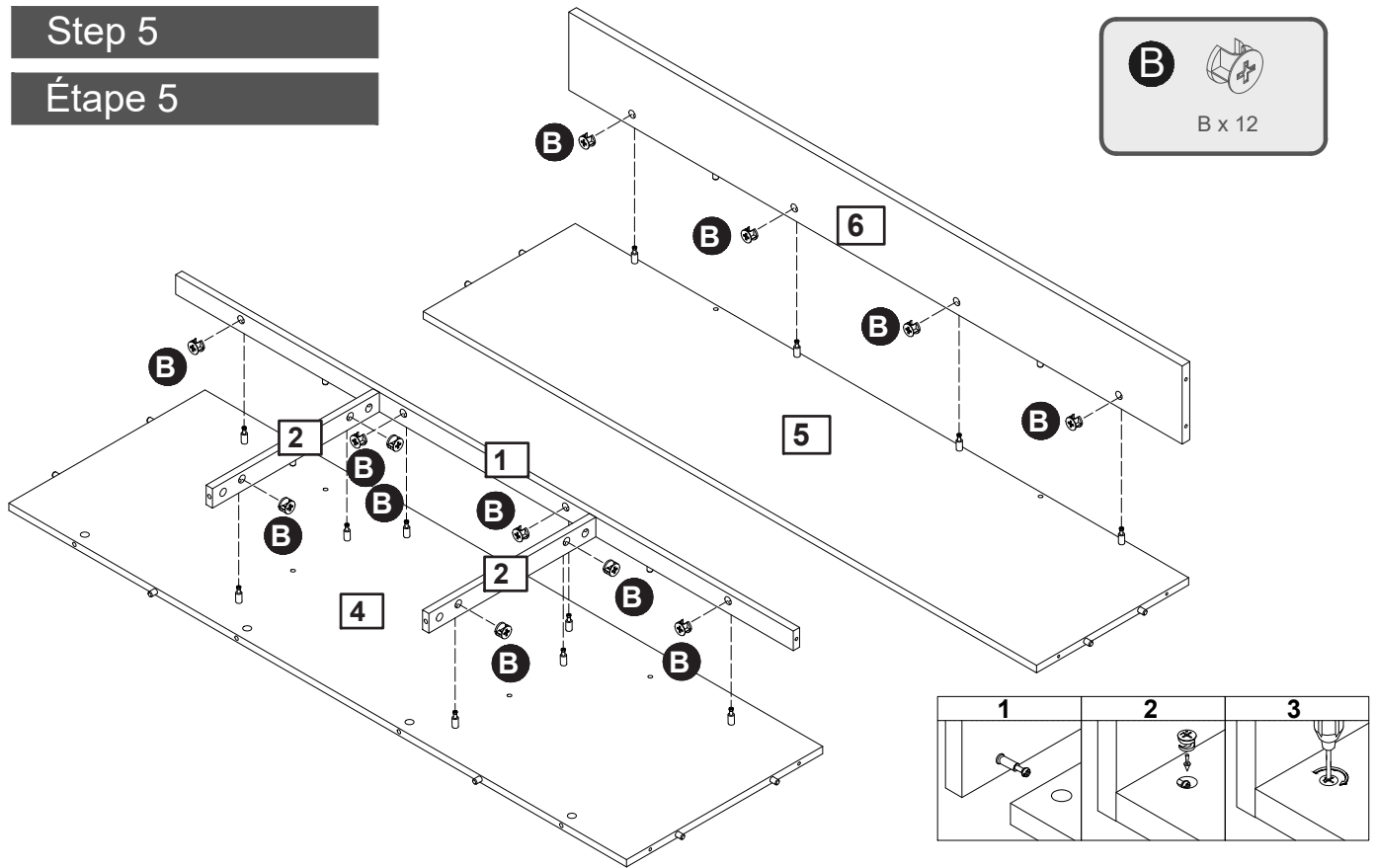

Step 6

Étape 6

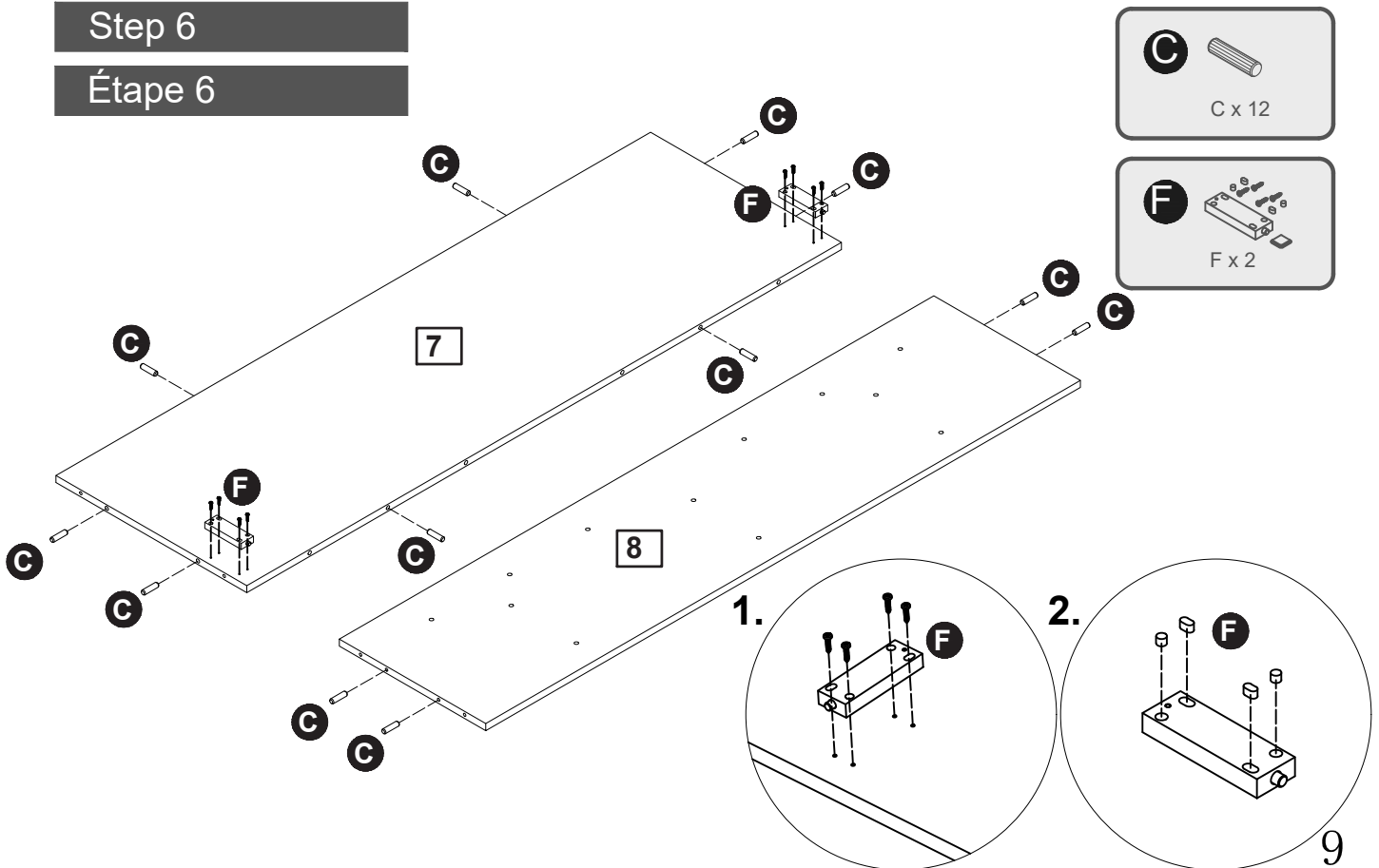

Assembly Instructions / Instructions de montage

Step 9

Étape 9

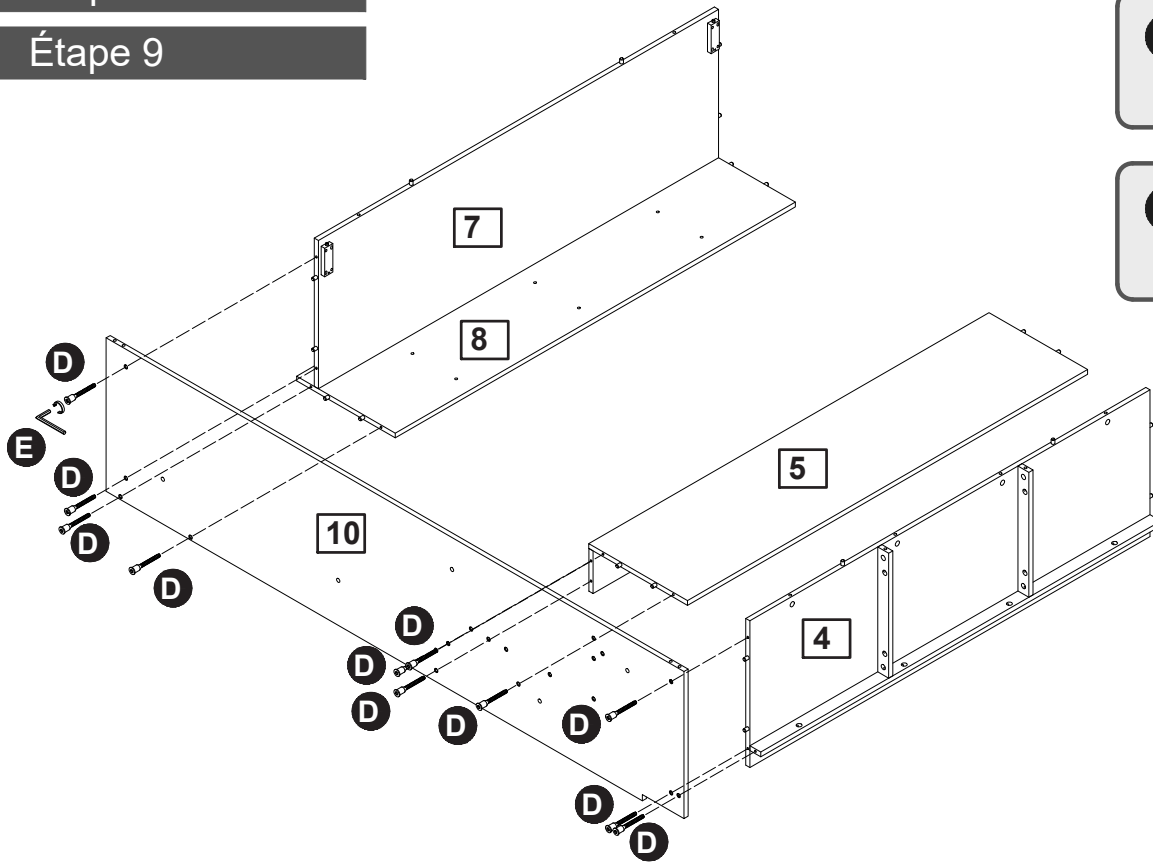

Step 10

Étape 10

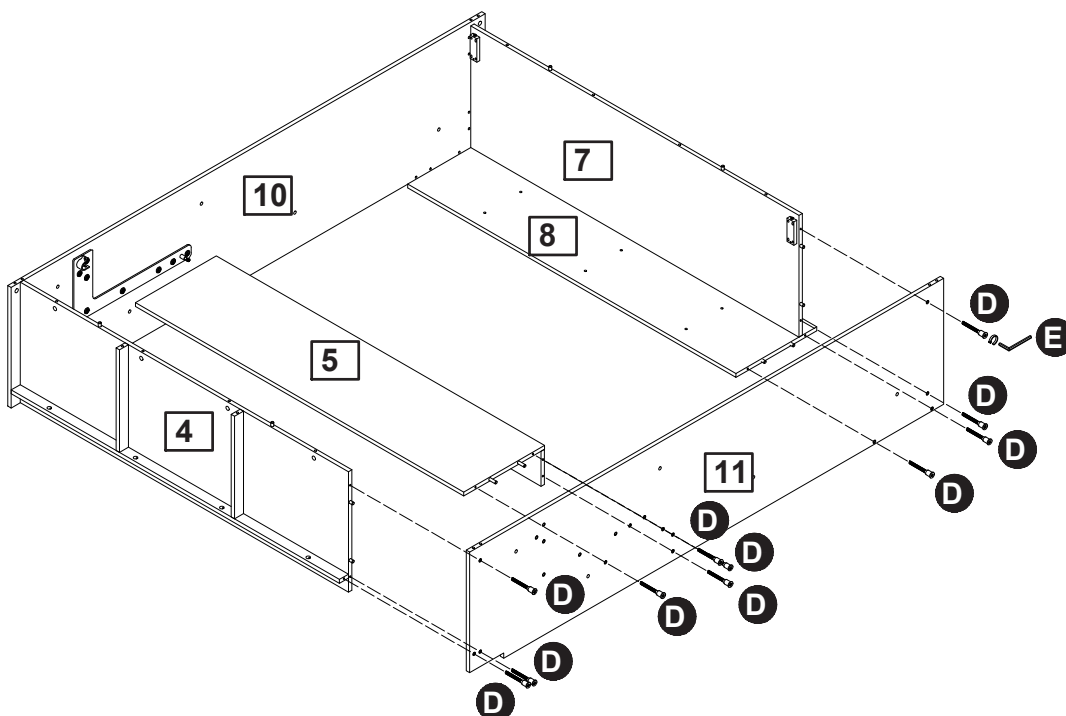

Assembly Instructions / Instructions de montage

Step 11

Étape 11

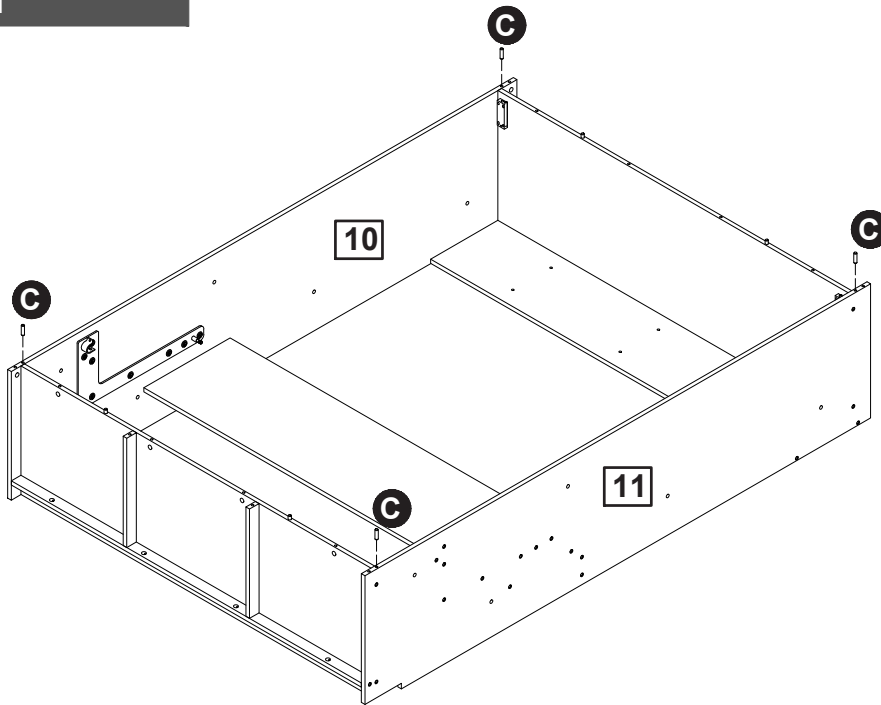
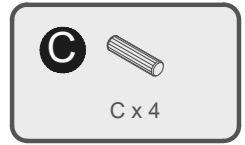

Step 12

Étape 12

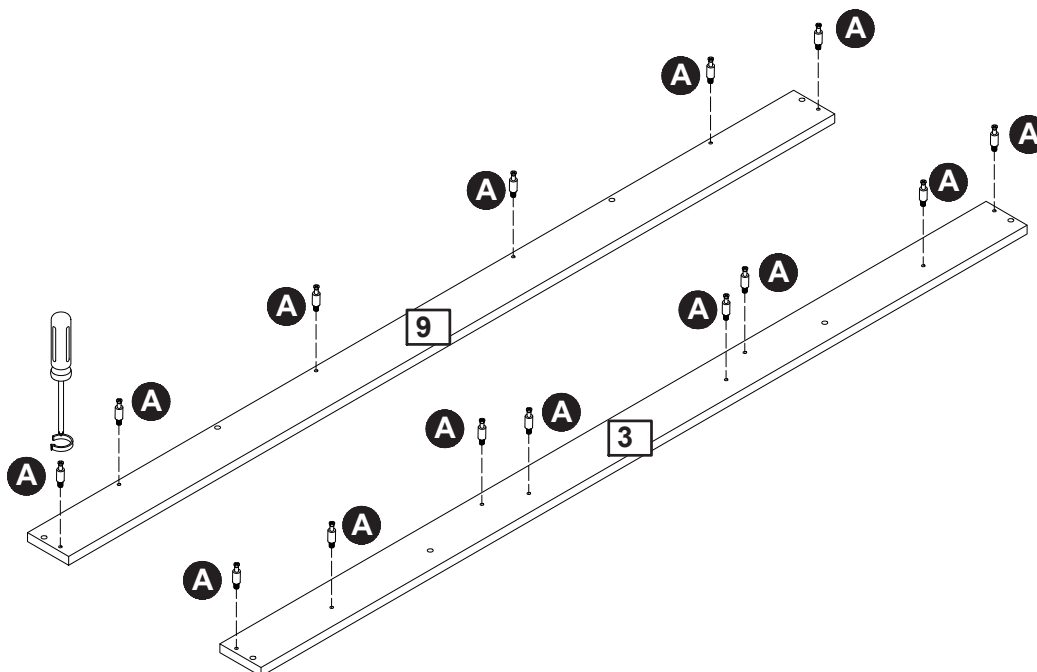

Assembly Instructions/ Instructions de montage

WALL ANCHORING INSTRUCTIONS / INSTRUCTIONS d'ancrage mural

INSTALLATION RECOMMENDATIONS-MASONRY Recommandations d'installation-maçonnerie

- 1** Determine the position of the bed in the room.
Déterminez la position du lit dans la chambre.

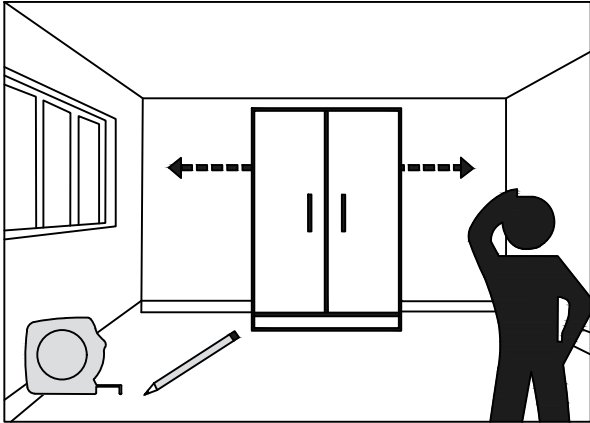

- 2** Put the bed back in its place, please keep it vertical and horizontal.
Remettez le lit à sa place. S'il vous plaît garder vertical et horizontal

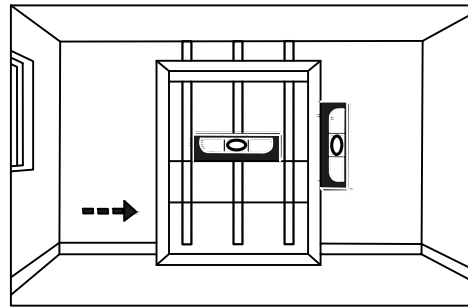

- 3** Pre-drill the piece of plywood #8 with 6 pilot holes of 3/8"(8mm) diameter distributed horizontally in order to cover the width of the anchoring section. With the bed in position, mark the position of the 6 holes on the masonry wall.
Pré-percer le morceau de contreplaqué #8 avec 6 trous pilotes de 3/8"(8mm) de diamètre répartis horizontalement afin de couvrir la largeur de la section d'ancrage. Avec le lit en position, marquez la position des 6 trous sur le mur de maçonnerie.

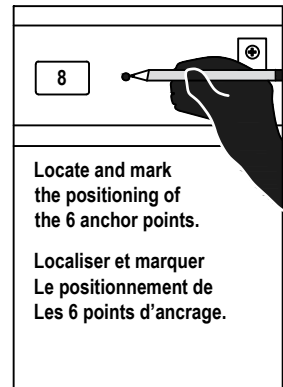
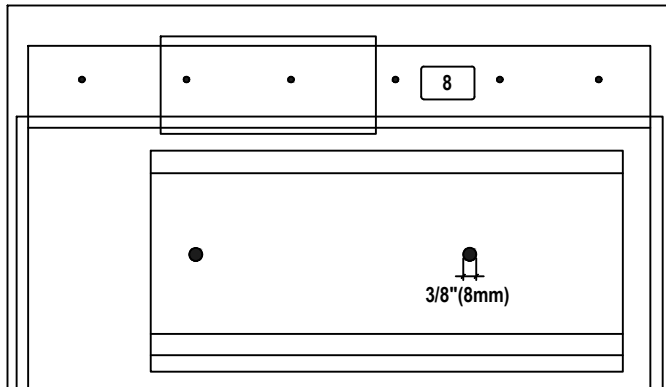
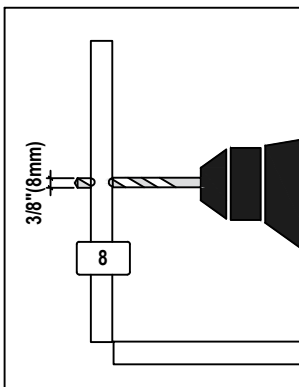

- 4** Move the bed again.
Remuez le lit.

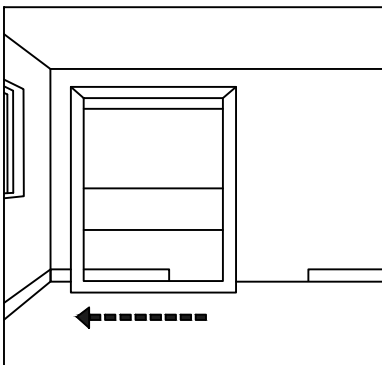

- 5** Using a 5/32"(10mm) diameter masonry bit, drill into the drywall and masonry (a hammer drill is required).
À l'aide d'un peu de maçonnerie de 5/32"(10mm) de diamètre, percer dans la cloison sèche et Maçonnerie (une perceuse à marteau est nécessaire).

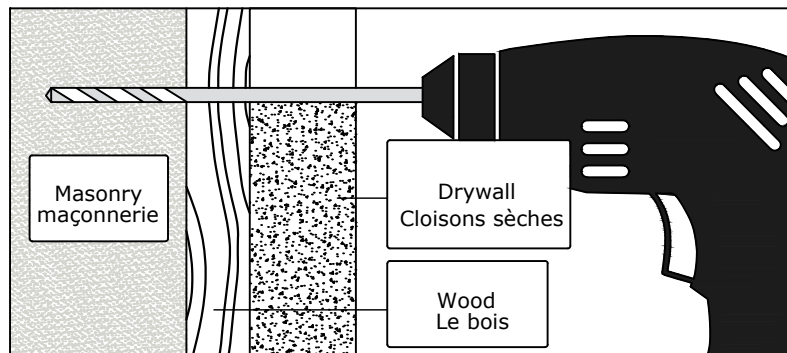

Assembly Instructions/ Instructions de montage

WALL ANCHORING INSTRUCTIONS / INSTRUCTIONS d'ancrage mural

INSTALLATION RECOMMENDATIONS-MASONRY Recommandations d'installation-maçonnerie

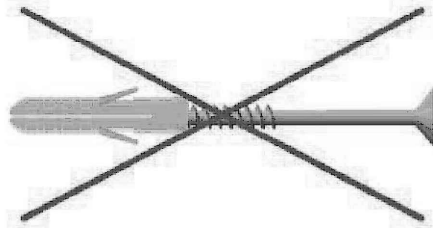
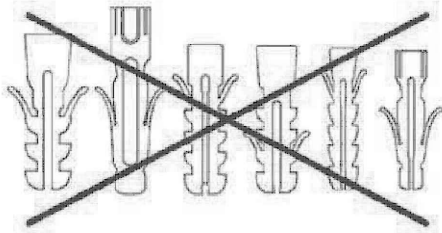

IMPORTANT WARNINGS / Avertissements importants



INSTALLATION AND APPROPRIATE HARDWARE

Using appropriate hardware, all the anchor screws of the wall bed must be firmly secured to the wood or metal studs, the structural components, or a masonry wall. Only wall anchor screws for wood-frame walls are provided with this bed.

INSTALLATION et matériel approprié

À l'aide de quincaillerie appropriée, toutes les vis d'ancrage du lit mural doivent être solidement fixées aux goujons en bois ou en métal, Les composants structurels, ou un mur de maçonnerie. Seules les vis d'ancrage pour les murs à ossature en bois sont fournies avec ce lit.

NUMBER OF SCREWS NEEDED

You need a total of six(6) wall anchor screws.

Nombre de vis nécessaires

Vous avez besoin d'un total de six(6) vis d'ancrage murale.

THE SCREWS MUST BE VERY WELL ANCHORED TO THE STRUCTURAL COMPONENTS OF THE WALL.

Les vis doivent être très bien ancrées aux composants structurels du mur.

- 6** Put the bed back in its place. put the CONCRETE SCREWS 3/8"(10mm)diameter X APPROPRIATE LENGTH into the holes of part #8 and screw the bed onto the masonry wall until thght against the wall. Screw must be at least 43/8"(110mm) deep into masonry. USE AN ELECTRIC SCREWDRIVER WITH AN ADJUSTABLE TENSION CLUTCH THAT HELPS PREVENT OVER-TIGHTENING AND STRIPPING.

Remettre le lit à sa place. Mettez les vis en béton 3/8"(10mm) de diamètre X longueur appropriée dans les trous de la pièce #8 et vissez le Lit sur le mur de maçonnerie jusqu'à ce que contre le mur. La vis doit avoir au moins 43/8"(110mm) de profondeur dans la maçonnerie. Utilisez un tournevis électrique Avec un embrayage de TENSION réglable qui aide à prévenir le serrage excessif et le décapage.

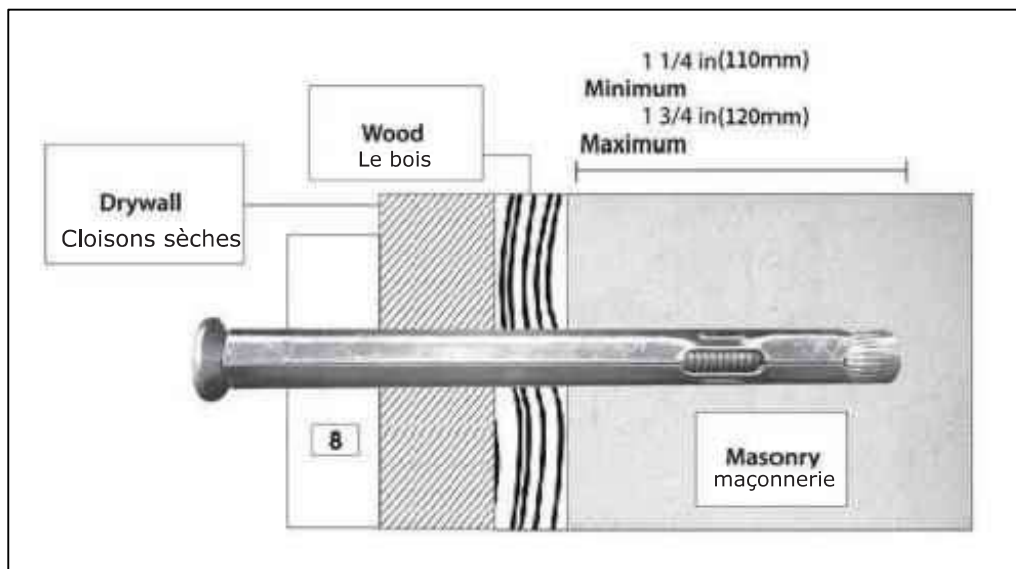

WALL ANCHORING REQUIREMENTS & INSTALLATION RECOMMENDATIONS

Important information to read before starting the assembly.
Keep this information for future reference.



IMPORTANT WARNINGS

Risk of serious injuries if the wall bed tips over.

To prevent wall bed from tipping over, mount it permanently to the wall.

Only a qualified person* must carry out the installation and any possible adjustment of the wall bed (including disassembly). If the wall bed is not firmly mounted (anchored) to the wall, it might tip over and cause serious injuries to the installer, users of the bed as well as the people near the bed.

The choice of wall anchoring depends on the type of wall. Use wall anchors suitable for the wall material.

* Qualified person: it is necessary to have a good understanding of the wall structure where the bed is anchored, including the positioning of the wall studs and structural components in the case of a wood or metal structure. If you do not have the necessary skills, make sure that the wall anchoring is done by someone who has the qualifications and required knowledge. When you choose the installer, make sure to comply with all applicable regulations in the province, state or country where the furniture is installed.

IMPORTANT WARNINGS



INSTALLATION AND APPROPRIATE HARDWARE

Using appropriate hardware, all the anchor screws of the wall bed must be firmly secured to the wood or metal studs, the structural components, or a masonry wall.

Only wall anchor screws for wood-frame walls are provided with this bed.

NEVER USE DRYWALL ANCHOR SCREWS OR SECURE THE BED TO DRYWALL

See wall anchoring requirements and installation notes provided in the instruction manual, according to the type of wall, and use the appropriate anchors such as described in this manual.

NUMBER OF SCREWS NEEDED

Two (2) screws are required for each anchor point. Three (3) wall anchor points are necessary for the proper installation of the wall bed. So you need a total of six (6) wall anchor screws.

THE SCREWS MUST BE VERY WELL ANCHORED TO THE STRUCTURAL COMPONENTS OF THE WALL.

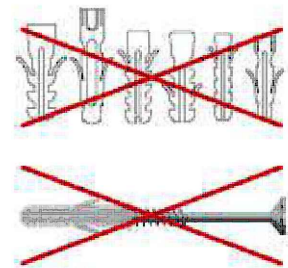

**** A CERTIFIED CONSTRUCTION PROFESSIONAL, IN COMPLIANCE WITH APPLICABLE REGULATIONS IN THE PROVINCE, STATE, OR COUNTRY WHERE THE FURNITURE IS INSTALLED.**

Exigences d'ancrage mural & Recommandations d'installation

Informations importantes à lire avant de démarrer l'assemblage.
Conservez cette information pour référence future.



Avertissements importants

Risque de blessures graves si le lit mural se renverse.

Pour empêcher le lit mural de basculer, montez-le en permanence au mur.

Seule une personne qualifiée * doit effectuer l'installation et tout ajustement éventuel du lit mural (y compris démontage). Si le lit de mur n'est pas fermement monté (ancré) au mur, il pourrait basculer et causer des iniuries graves à l'installateur, les utilisateurs du lit ainsi que les personnes à proximité du lit. Le choix de l'ancrage mural dépend du type de mur. Utilisez des ancrages muraux adaptés au matériau du mur.

*Personne qualifiée: il est nécessaire d'avoir une bonne compréhension de la structure murale où le lit est ancré, y compris le positionnement des goujons muraux et des éléments structuraux dans le cas d'une structure en bois ou en métal. Lf vous n'avez pas les compétences nécessaires, assurez-vous que l'ancrage mural est fait par quelqu'un qui a les qualifications et les connaissances requises. Lorsque vous choisissez l'installateur, assurez-vous de respecter toutes les exigences applicables dans la province, l'état ou le pays où les meubles sont installés.

Avertissements importants



INSTALLATION et matériel approprié

En utilisant le matériel approprié, toutes les vis d'ancrage du lit de mur doivent être fermement fixées aux goujons de bois ou de métal, aux composants structuraux, ou à un mur de maçonnerie.

Seules les vis d'ancrage pour les murs à ossature en bois sont fournies avec ce lit.

Ne jamais utiliser de vis d'ancrage de cloisons sèches ou fixer le lit à la cloison sèche

Voir les exigences d'ancrage mural et les notes d'installation fournies dans le manuel d'instruction, selon le type de mur, et employez le matériel approprié ancrés telles que décrites dans ce manuel.

Nombre de vis nécessaires

Deux (2) vis sont nécessaires pour chaque point d'ancrage. Trois (3) points d'ancrage muraux sont nécessaires pour la bonne installation du lit mural. Vous avez donc besoin d'un total de six (6) vis d'ancrage murale.

**Les vis doivent être très bien ancrées à la structure
Composants du mur.**

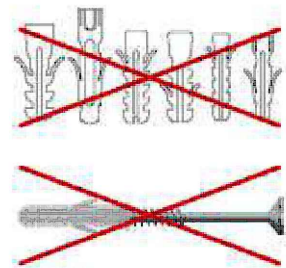

**** Un professionnel certifié CONSTRUCTON, en conformité avec la réglementation APPLICABLE dans la PROVINCE.
Pays où les meubles sont installés.**

Assembly Instructions / Instructions de montage

Step 13

Étape 13

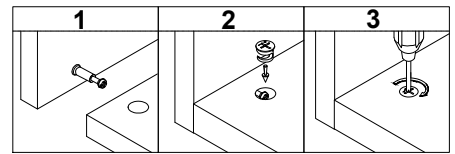
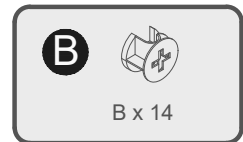
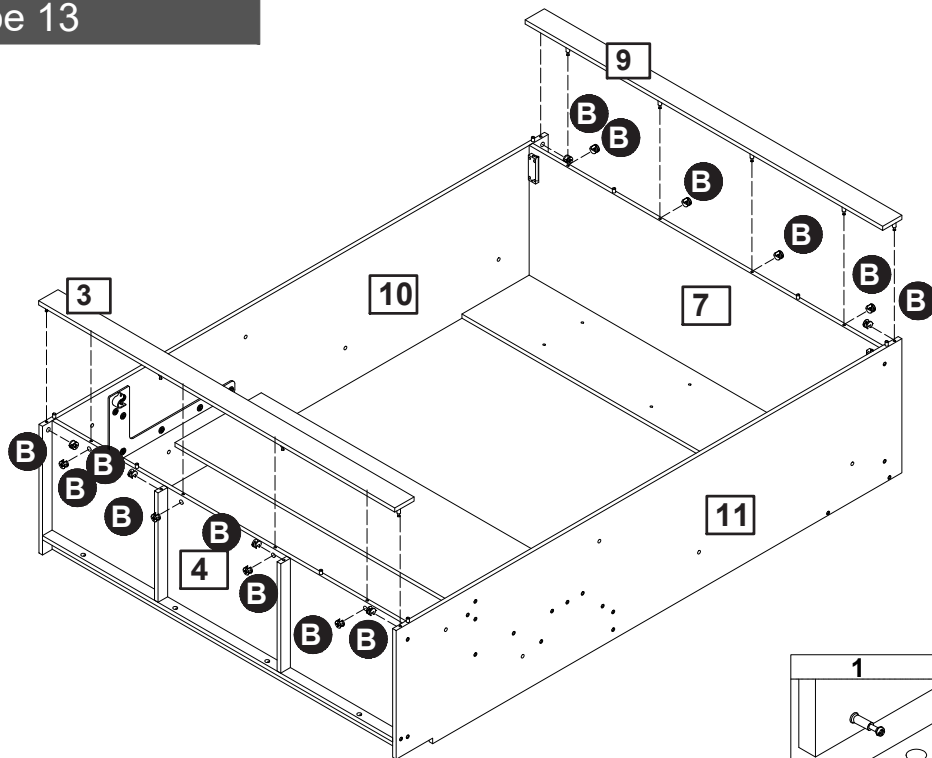

Step 14

Étape 14

WALL

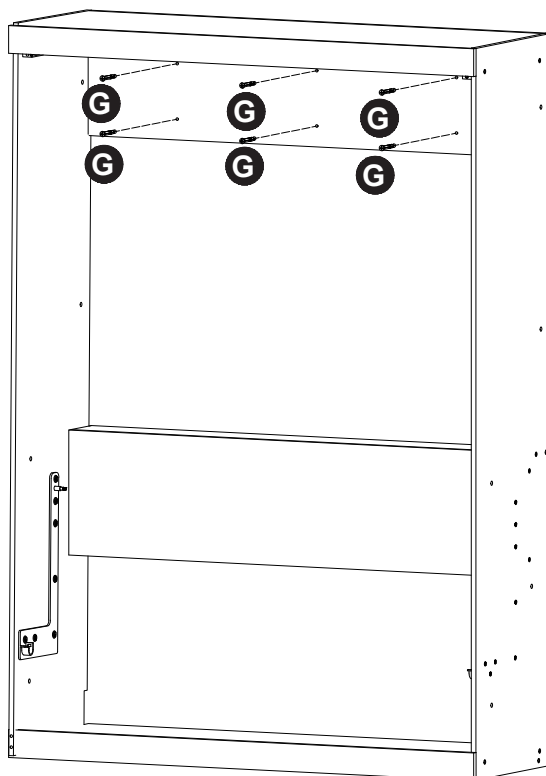

Three people are required to assemble and move this model.
Trois personnes sont nécessaires pour Assembler et déplacer ce modèle.

Assembly Instructions / Instructions de montage

Step 15

Étape 15

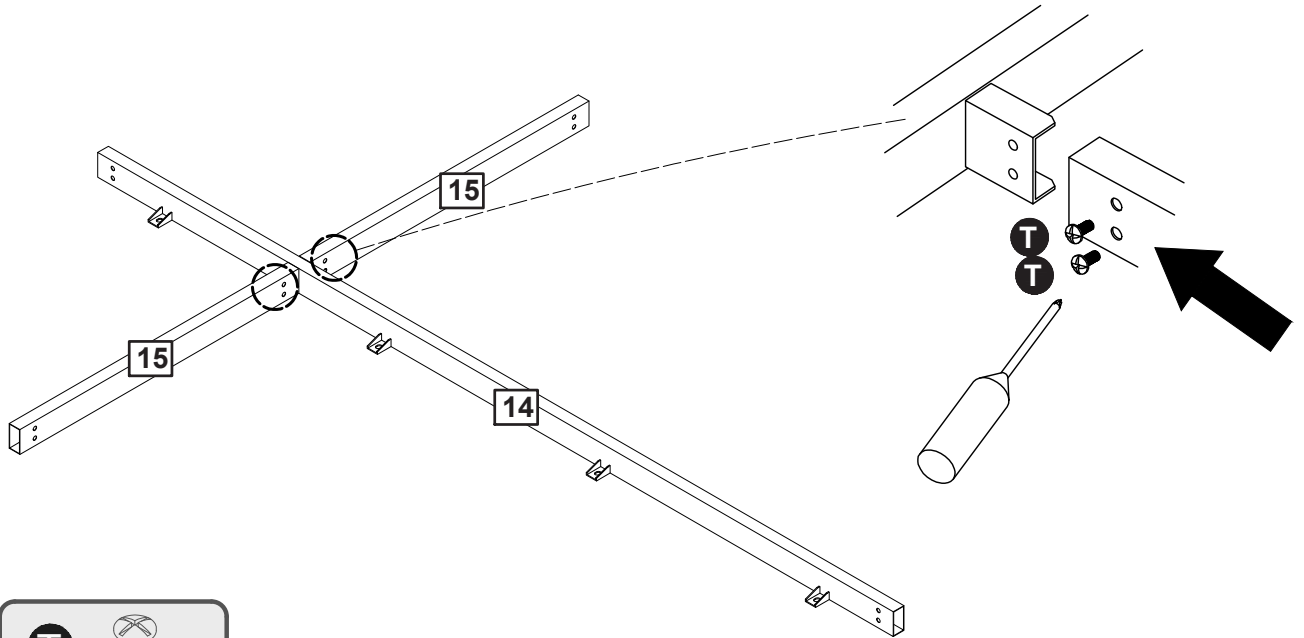

Step 16

Étape 16

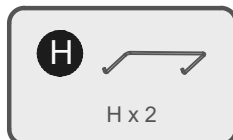
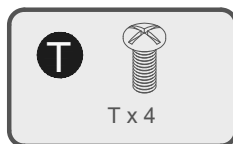
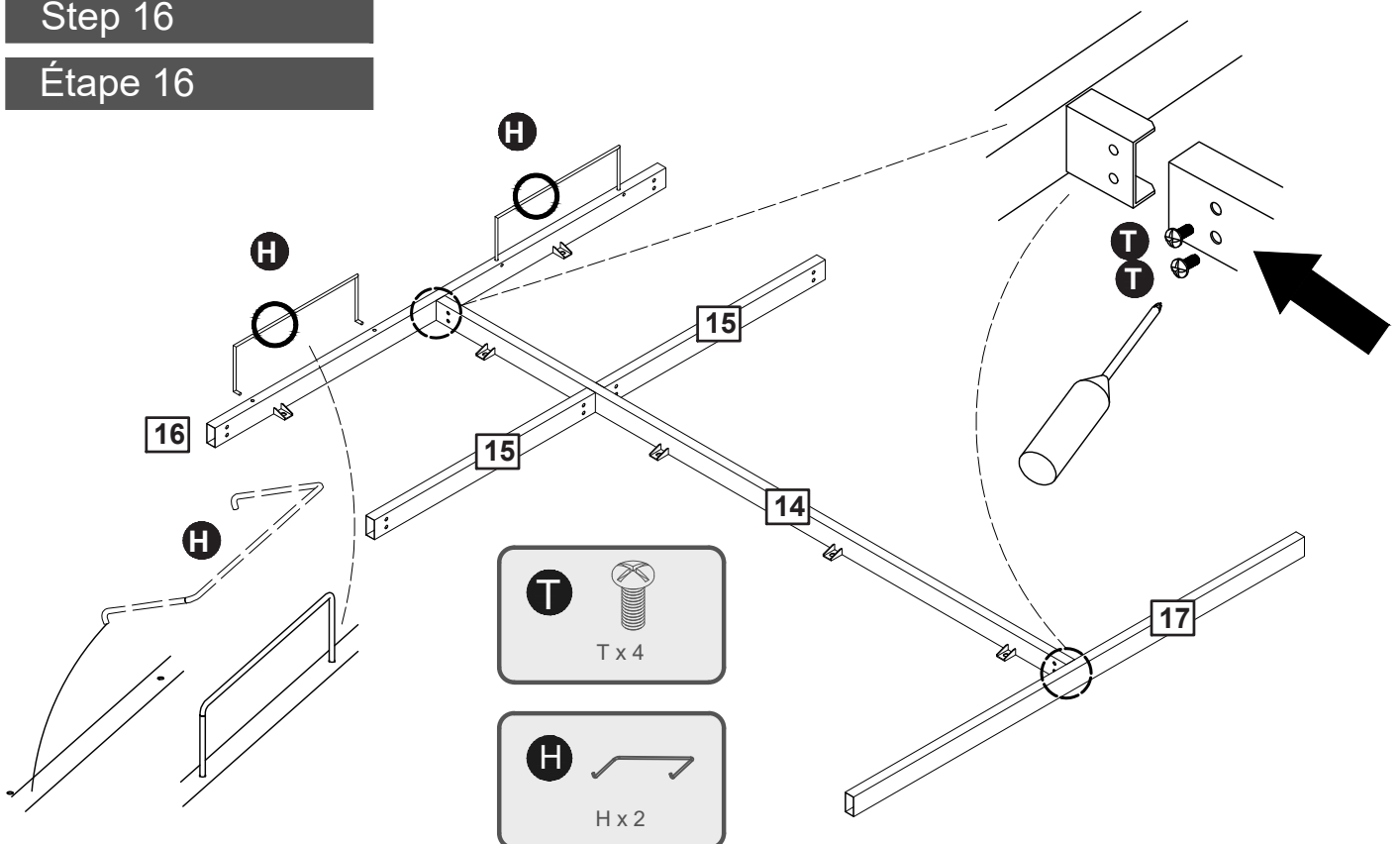

Assembly Instructions / Instructions de montage

Step 17

Étape 17

make sure the tube with mattress stopper holes is in the head position and the tube without any holes are in the foot part. after you assemble the frame, take the measurement to ensure $X=Y$

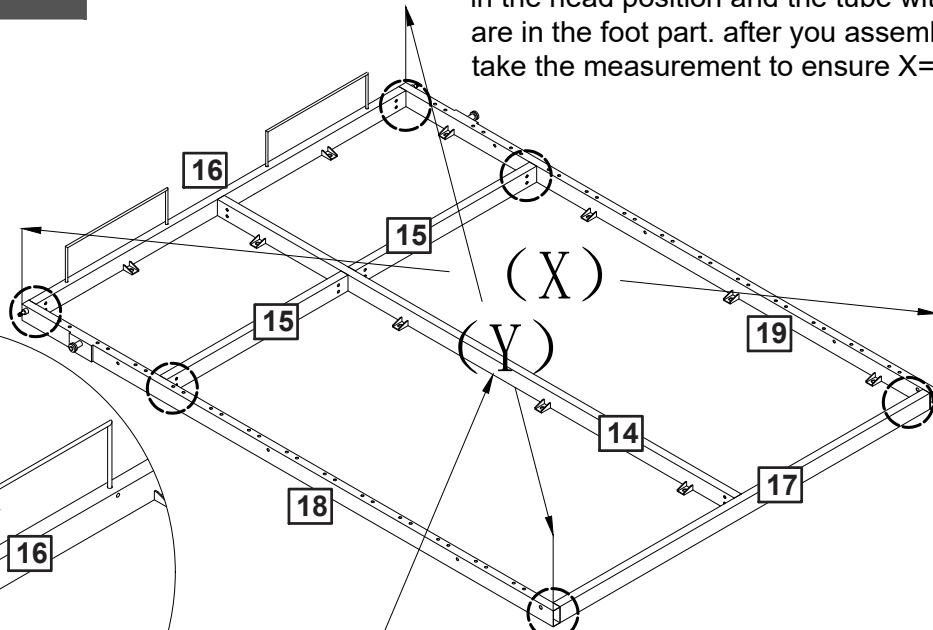
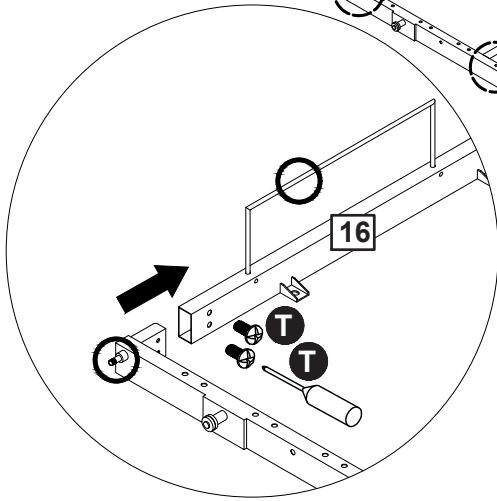

$$(X) = (Y)$$

Assurez-vous que le tube avec des trous de bouchon de matelas est en position tête et que le tube sans aucun trou est dans la partie du pied. Après avoir assemblé le cadre, prenez la mesure pour vous assurer $X=Y$

Step 18

Étape 18

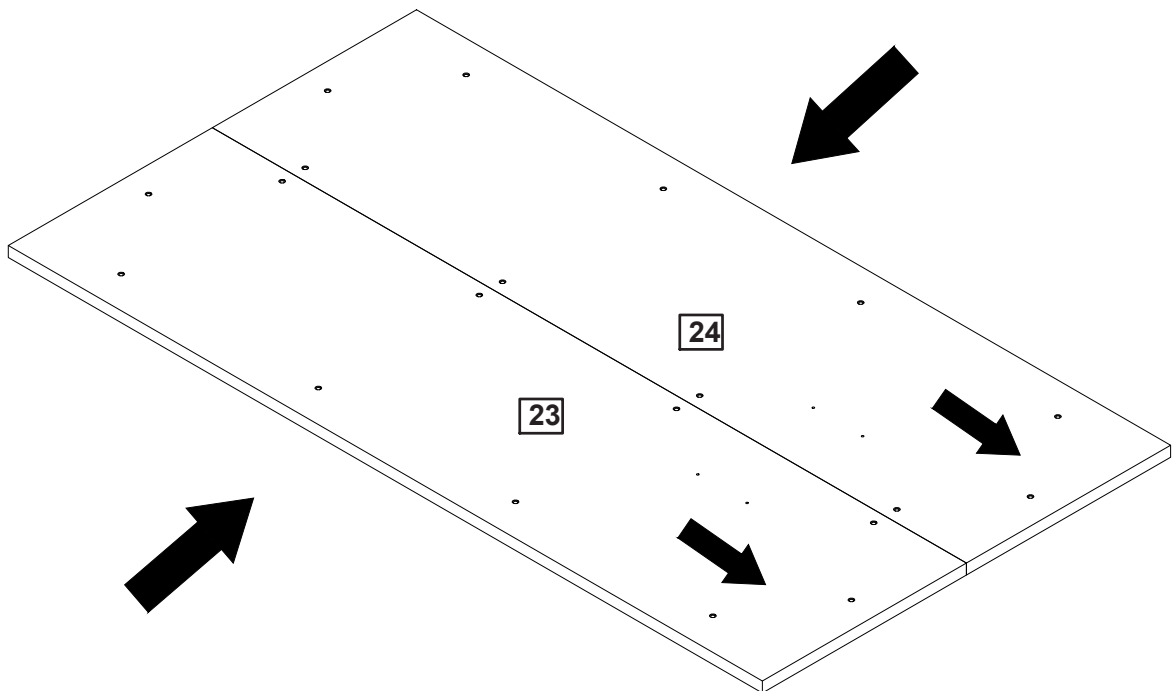

Assembly Instructions / Instructions de montage

Step 19

Étape 19

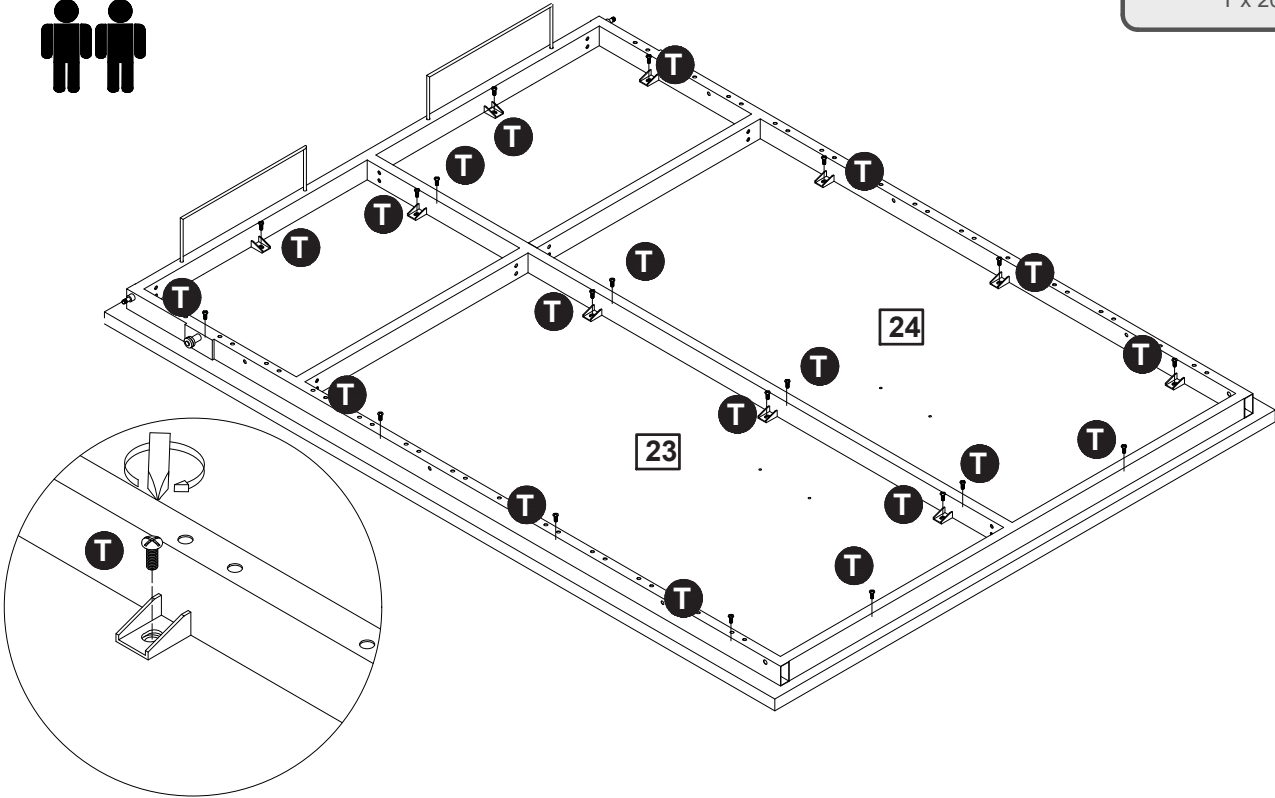
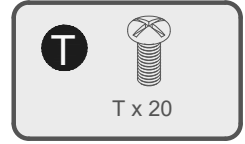

Step 20

Étape 20

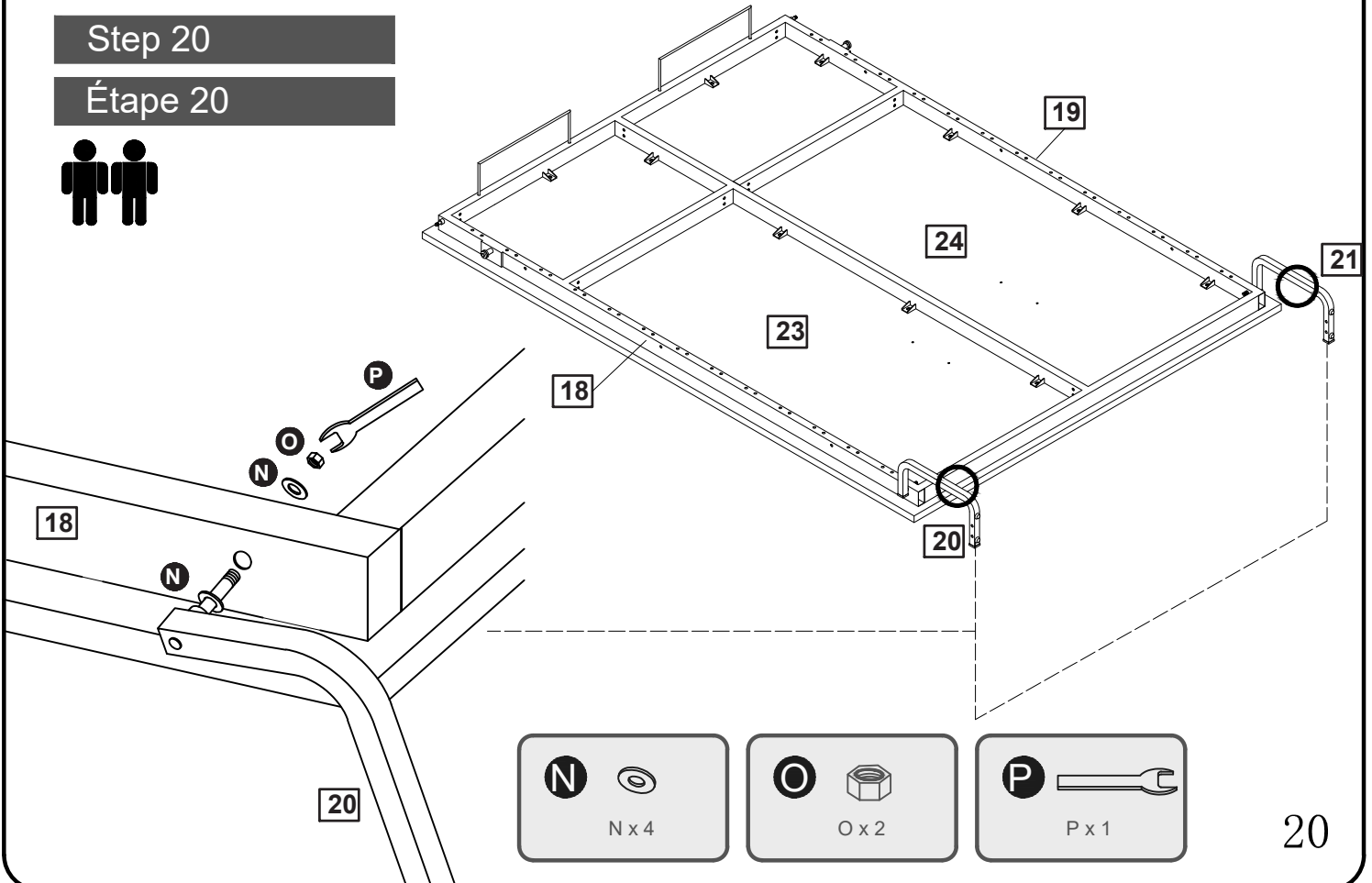

Assembly Instructions / Instructions de montage

Step 21

Étape 21

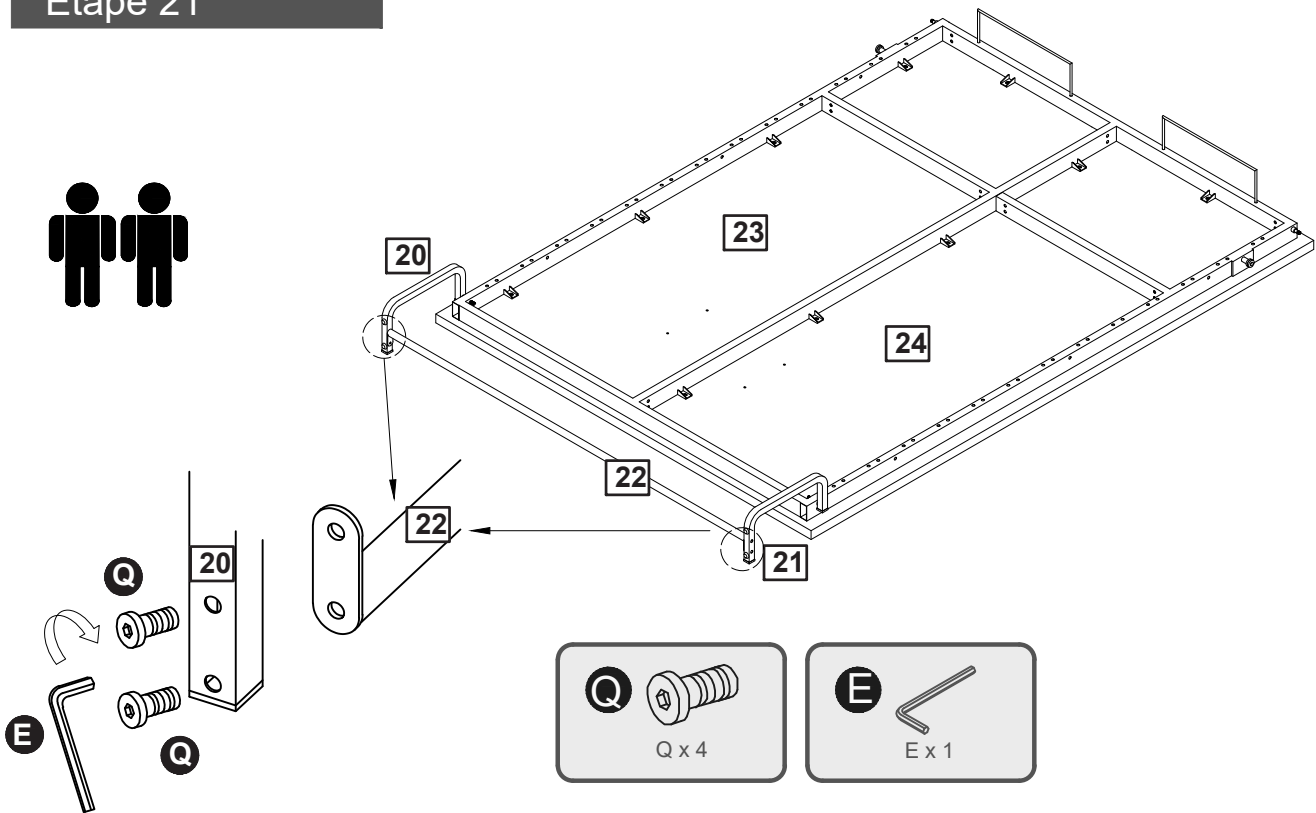
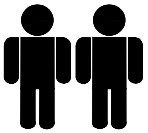

Step 22

Étape 22

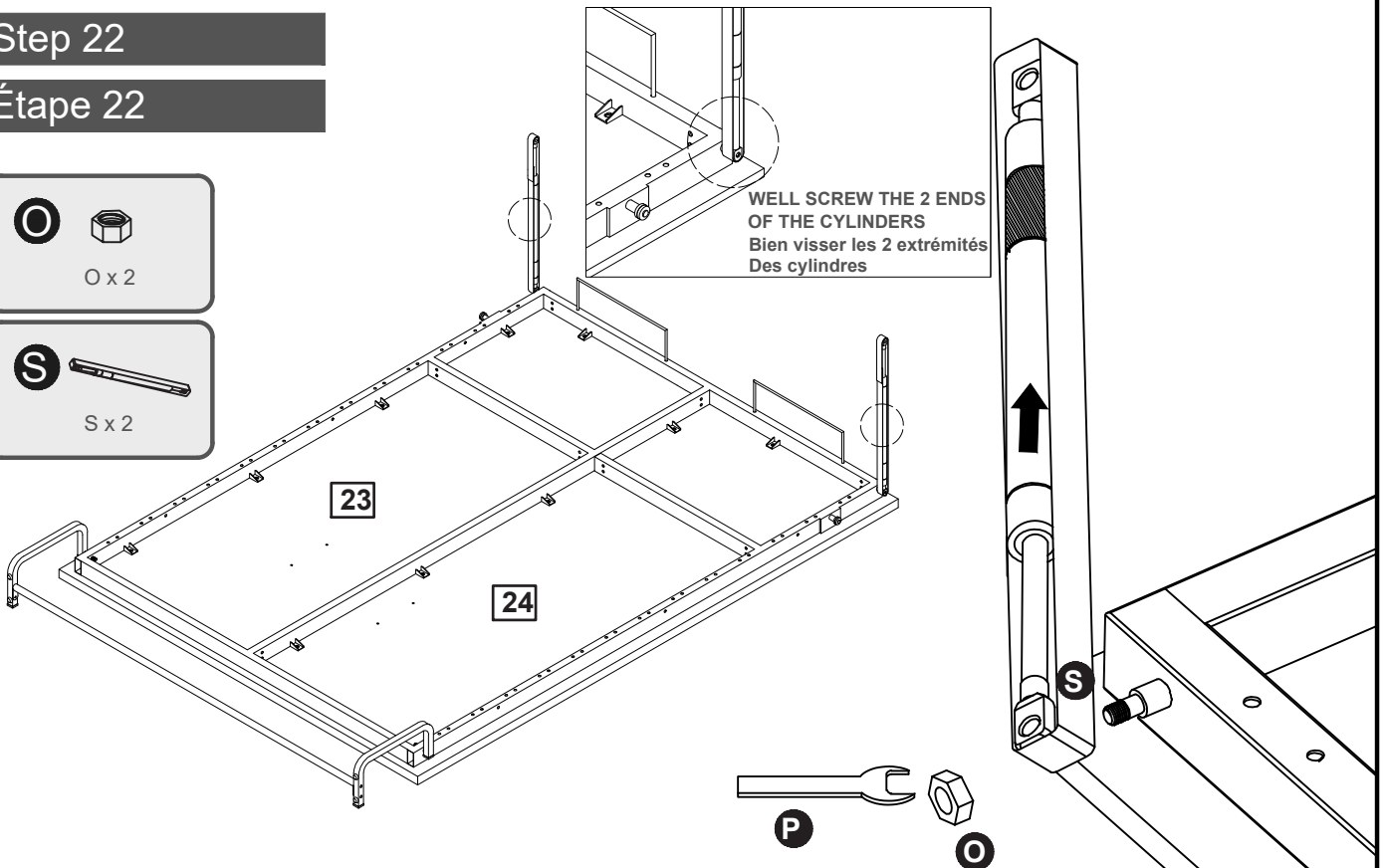
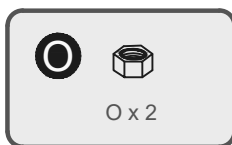

Do not release the cylinders until finished the installation
Ne relâchez pas les cylindres jusqu'à ce que l'implantation soit terminée

21

Assembly Instructions / Instructions de montage

Step 23

Étape 23

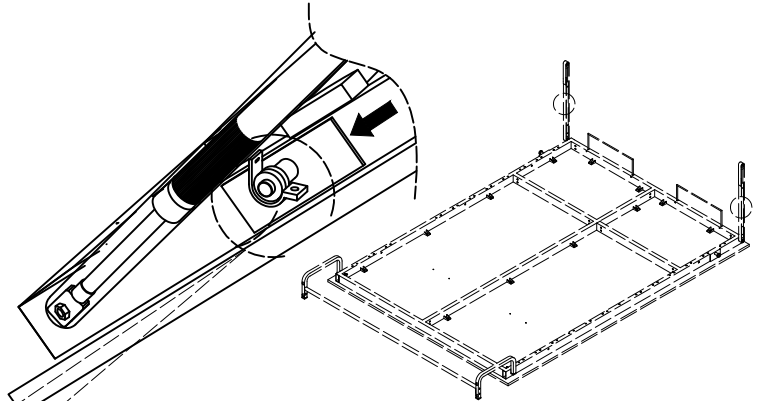
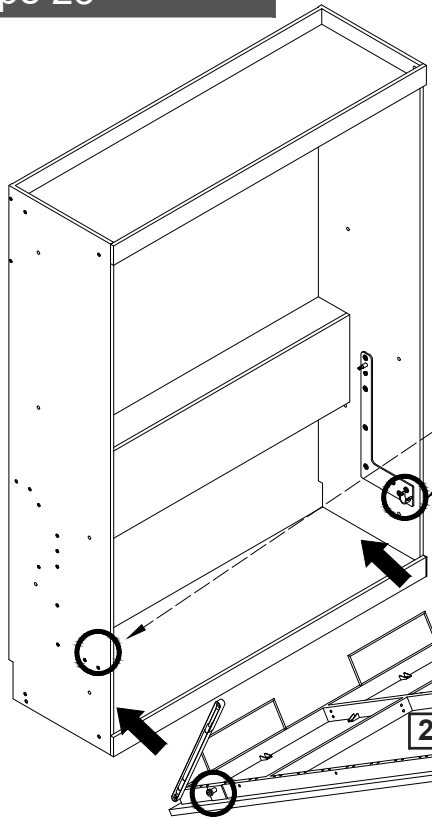

Three people are required to assemble and move this model.
Trois personnes sont nécessaires pour Assembler et déplacer ce modèle.

Important

1. Place the bearings equal on each side before fixing them up.
2. Well positioning the bearing support in such a way as to lock.
3. Tighten strongly the bearing support.

1. Placez les roulements égaux de chaque côté avant de les fixer.
2. Bien positionner le support du roulement de manière à se verrouiller.
3. Serrez fortement le support d'incidence.

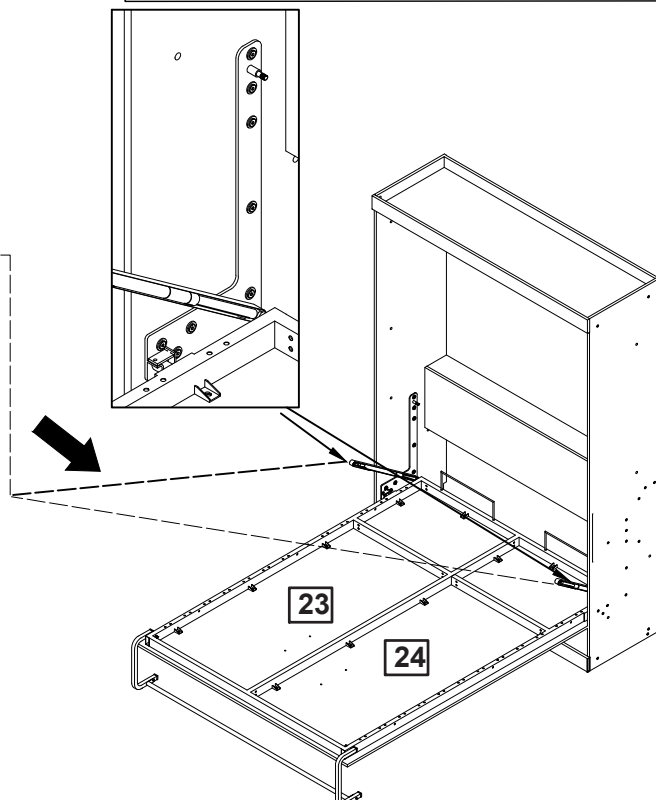
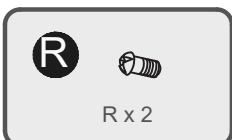
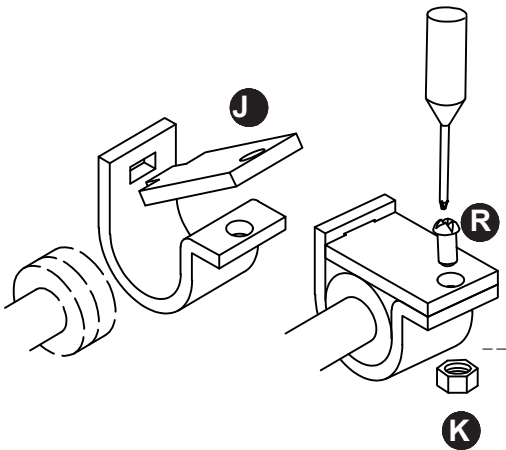

Assembly Instructions / Instructions de montage

Step 24

Étape 24



Three people are required to assemble and move this model.
Trois personnes sont nécessaires pour Assembler et déplacer ce modèle.

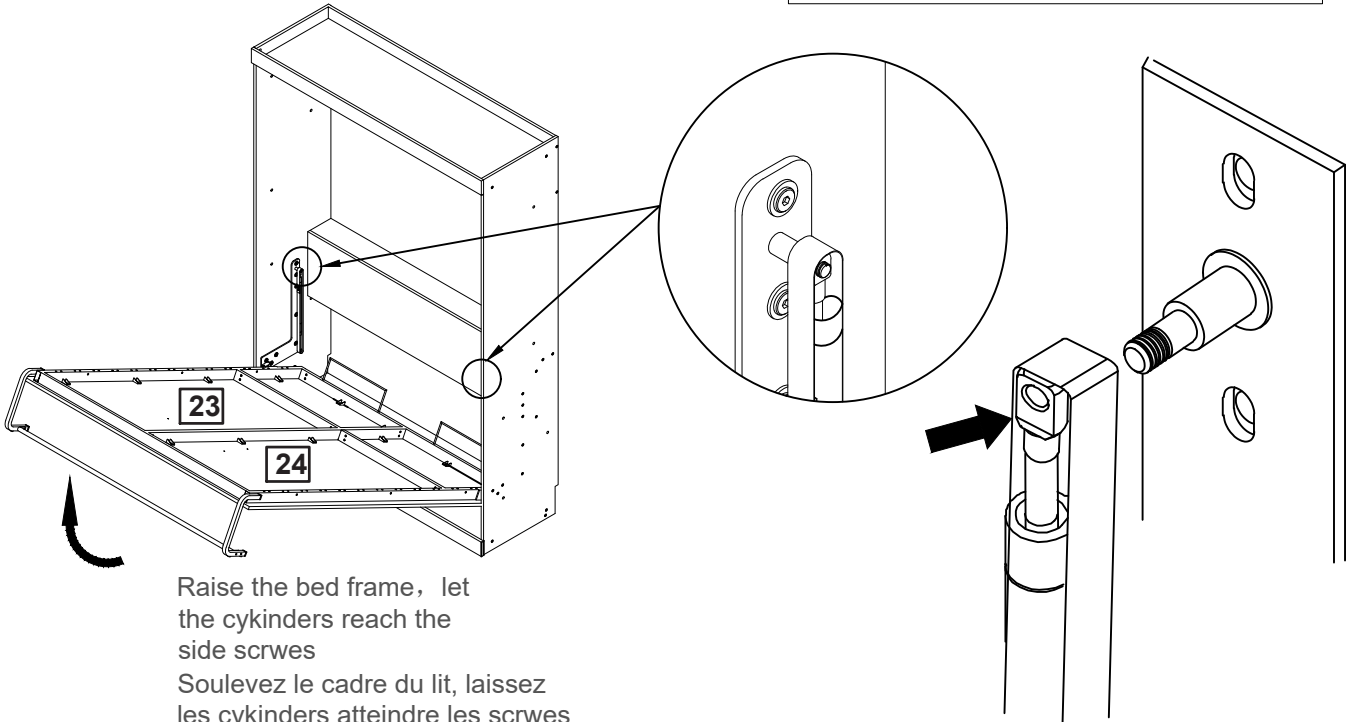

Raise the bed frame, let the rollers reach the side screws
Soulevez le cadre du lit, laissez les cylindres atteindre les vis latérales

Step 25

Étape 25



INSERT CYLINDER ON ITS STEM
Insérez le cylindre sur sa tige

S must be completely tightened
Doit être complètement serré

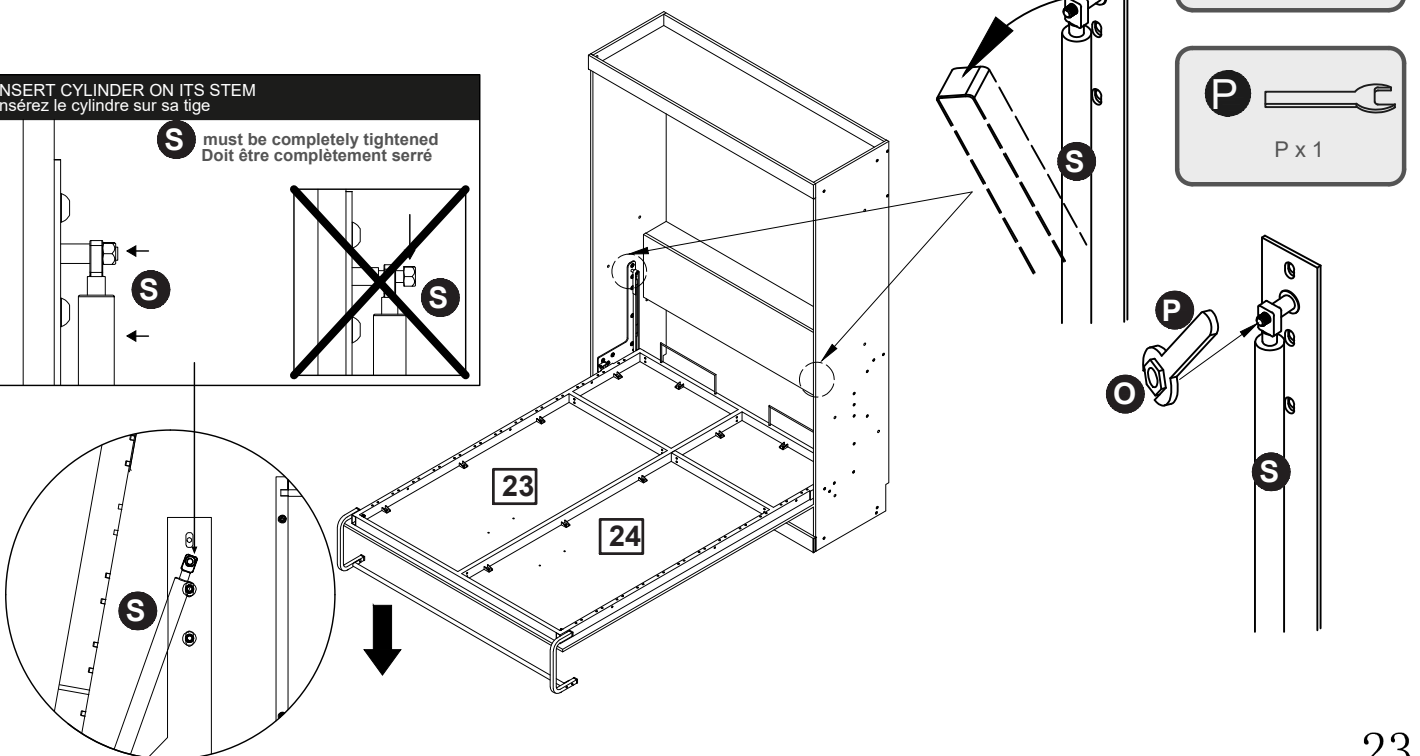
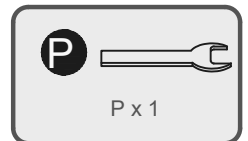
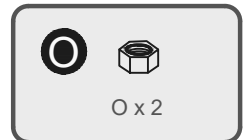
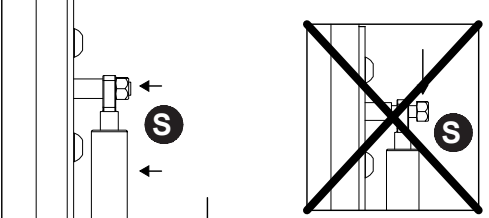

Assembly Instructions / Instructions de montage

Step 26

Étape 26

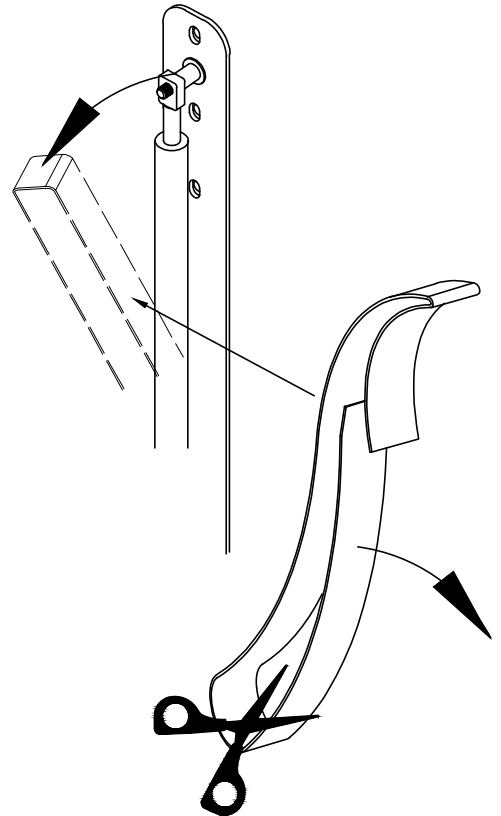
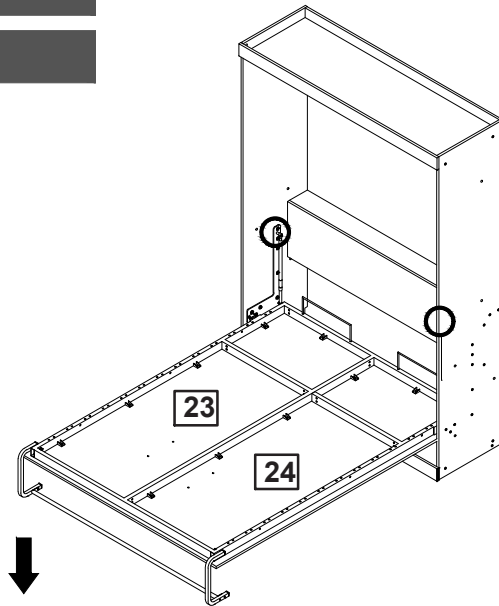

Important

The fixed cykinder metal could cut off with scissors

Take note that after the installation of the pistons, it will be very difficult to open the bed. Continue the steps until the end, put the mattress on, and the bed will open without effort.

Le métal cykinder fixe pourrait couper avec des ciseaux

Prenez note qu'après l'installation des pistons, il sera très difficile d'ouvrir le lit, continuer les marches jusqu'à la fin, mettre le matelas. Et le lit s'ouvrira sans effort.

Step 27

Étape 27

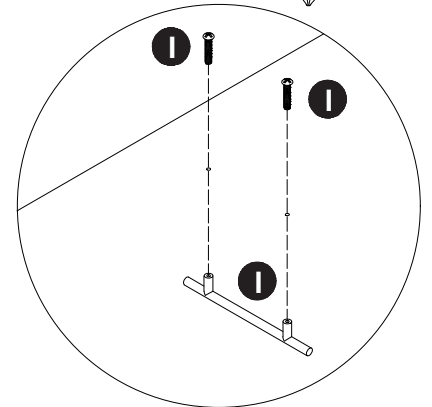
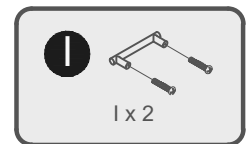
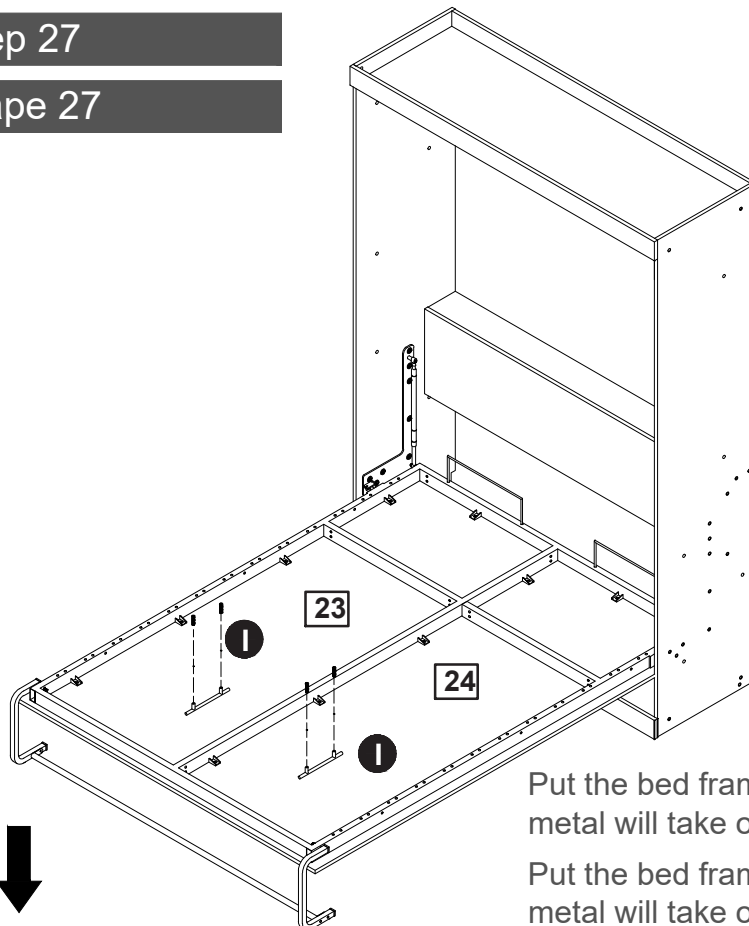

Put the bed frame down ,the fixed cykinder metal will take off automatically

Put the bed frame down ,the fixed cykinder metal will take off automatically

Assembly Instructions / Instructions de montage

Step 28

Étape 26

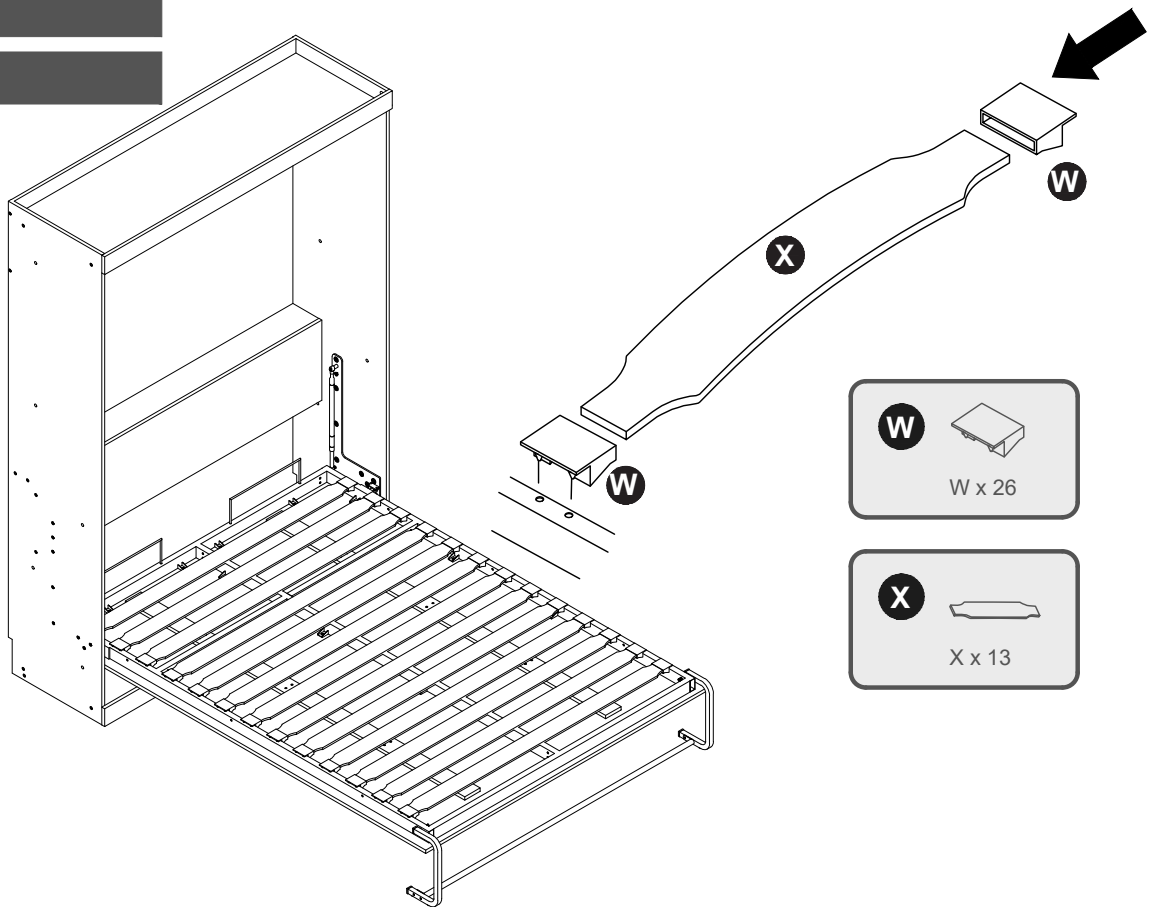

Step 29

Étape 29

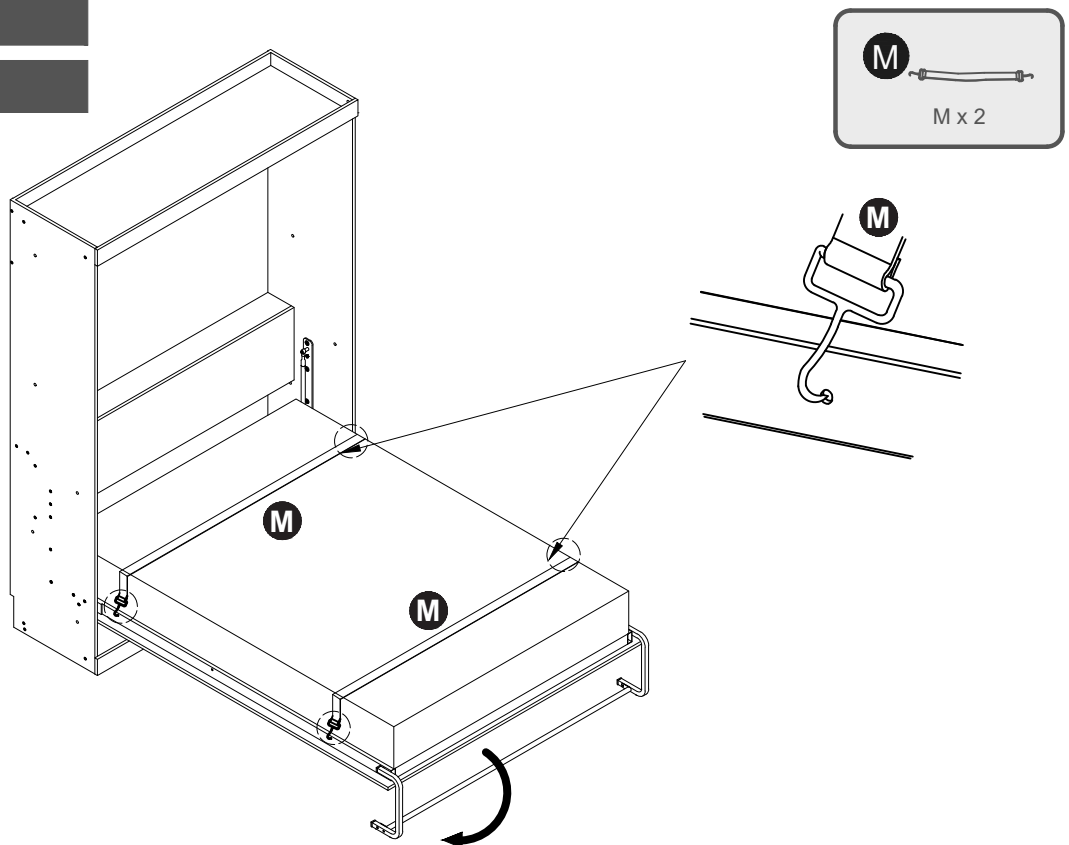

Please open the leg before completely lower the bed.
Veuillez ouvrir la jambe avant d'abaisser complètement le lit.

Assembly Instructions / Instructions de montage

Step 30

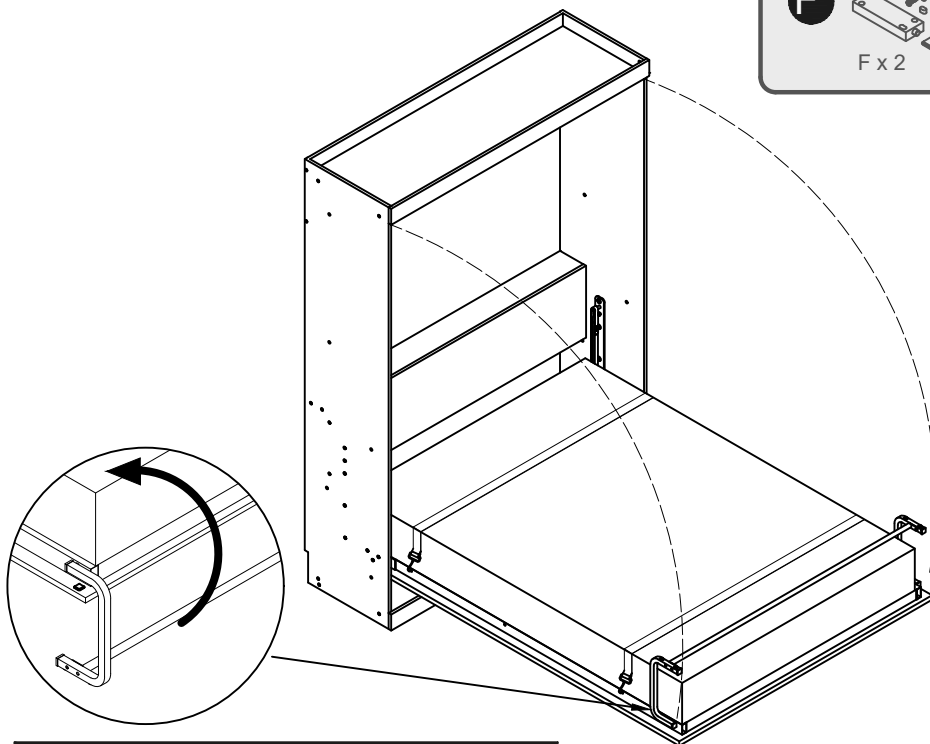
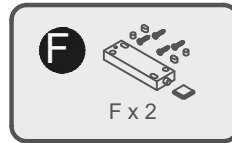

1.

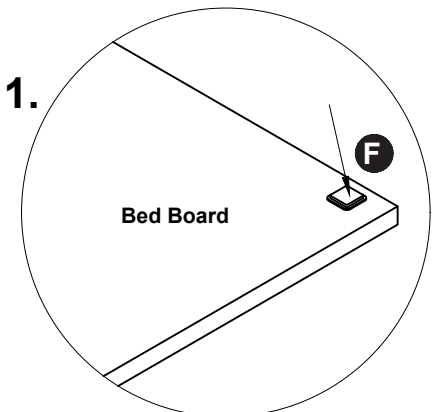

2.

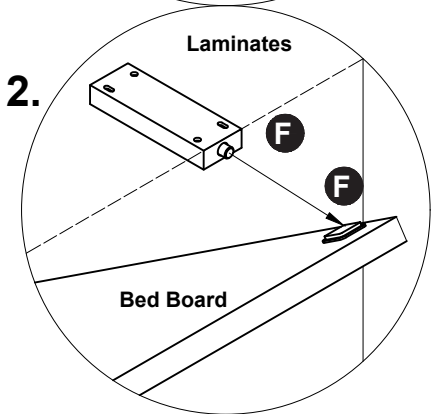

Important

Rotate the leg towards the interior when close the door
Tourner la jambe vers l'intérieur quand fermer la porte

Step 31

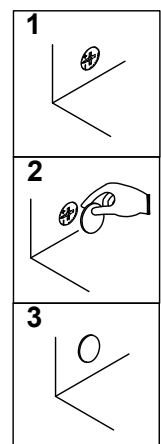
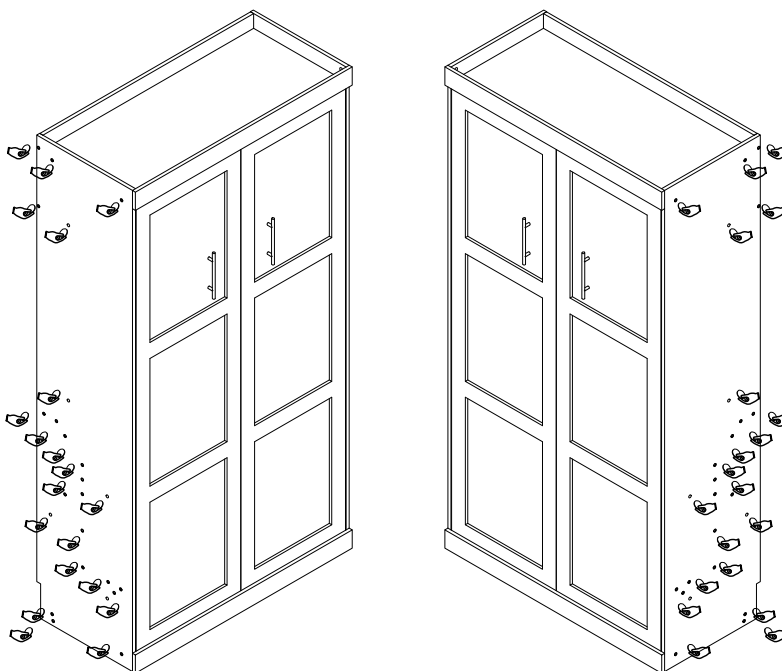
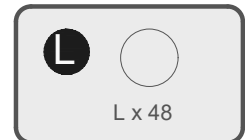

Assembly is complete.
L'assemblage est terminé.

Use cykinder metal(Y) to remove cykinders

Utilisez cykinder metal(Y) pour supprimer les cykinders

Step 1

Étape 1

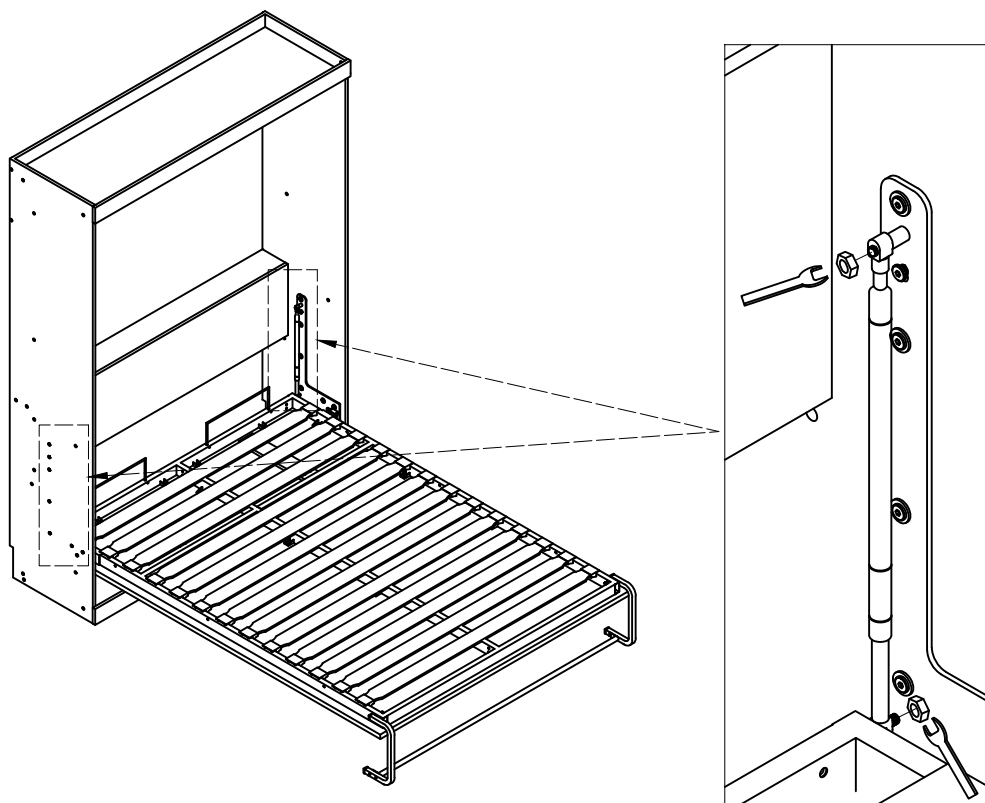

1. Customer could use Y to remove cykinders when the bed need to be moved or uninstalled

2. Loosen the screw of the cykinders

1. Le client pourrait employer Y pour enlever des cykinders quand le lit doit être déplacé ou désinstallé

2. Desserrer la vis des cykinders

Step 2

Étape 2

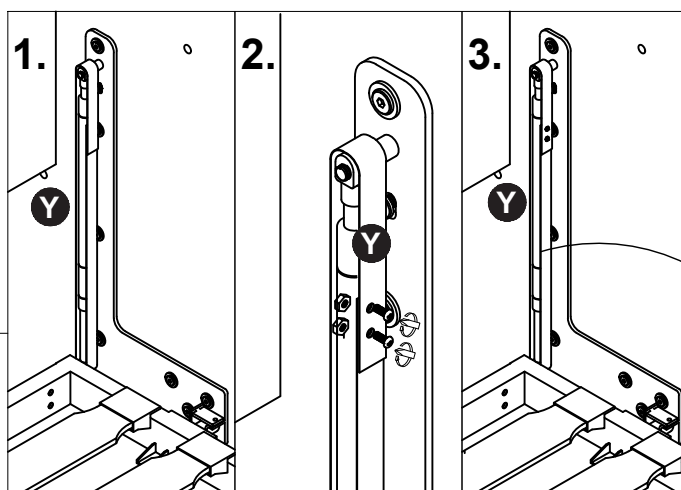
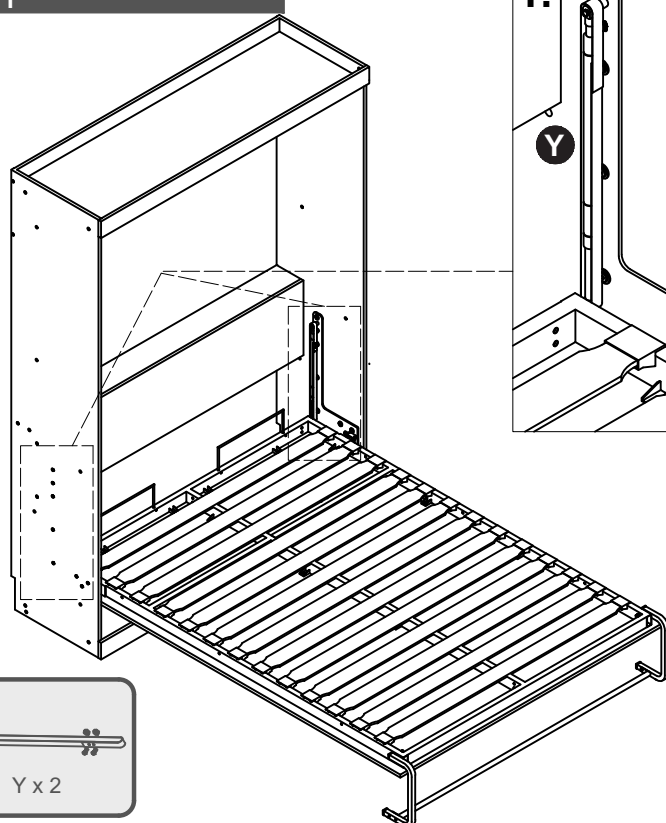

Attention! The cykinders can not be removed until (Y) has been installed

Attention! Les cykinders ne peuvent pas être Retiré jusqu'à ce que (Y) ait été installé

