



**INSTRUCTIONS D'ASSEMBLAGE  
ASSEMBLY INSTRUCTIONS**

---

---

**BUREAU -  
48"L / HAUTEUR ADJUSTABLE NOYER / METAL NOIR**

**COMPUTER DESK -  
48"L / WALNUT / ADJ.HEIGHT/ BLACK METAL**







**POUR DE L'ASSISTANCE OU POUR COMMANDER  
DES PIÈCES CONTACTEZ NOTRE DÉPARTEMENT  
DE SERVICE À LA CLIENTÈLE.**

**FOR ASSISTANCE OR TO ORDER PARTS  
CONTACT OUR CUSTOMER SERVICE DEPARTMENT**

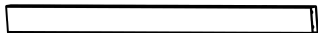
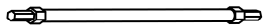

## LISTE DES PIÈCES PARTS LIST

| PIÈCE / PART # | IMAGE   | DESCRIPTION   | QTY / QTÉ |
|----------------|---|---|-----------|
| <b>1</b>       |    | <b>FRONT FACING RIGHT LEG<br/>PATTE AVANT DROITE</b>  | <b>1</b>  |
| <b>2</b>       |    | <b>BACK FACING RIGHT LEG<br/>PATTE ARRIÈRE DROITE</b> | <b>1</b>  |
| <b>3</b>       |  | <b>BACK FACING LEFT LEG<br/>PATTE ARRIÈRE GAUCHE</b>  | <b>1</b>  |
| <b>4</b>       |  | <b>FRONT FACING LEFT LEG<br/>PATTE AVANT GAUCHE</b>   | <b>1</b>  |
| <b>5</b>       |  | <b>CROSSBAR (TOP)<br/>BARRE TRANSVERSALE (HAUT)</b>   | <b>2</b>  |

**LISTE DES PIÈCES**  
**PARTS LIST**

| PIÈCE / PART # | IMAGE   | DESCRIPTION   | QTY / QTÉ |
|----------------|---|---|-----------|
| 6              |    | <b>SUPPORT BAR</b><br><b>BARRE DE SOUTIEN</b>               | 2         |
| 7              |    | <b>CROSSBAR (BOTTOM)</b><br><b>BARRE TRANSVERSALE (BAS)</b> | 2         |
| 8              |  | <b>BACK STRETCHER</b><br><b>DOSSIER</b>                     | 1         |
| 9              |  | <b>CONNECTOR</b><br><b>CONNECTEUR</b>                       | 1         |
| 10             |  | <b>CONNECTOR</b><br><b>CONNECTEUR</b>                       | 1         |

**LISTE DES PIÈCES**  
**PARTS LIST**

| PIÈCE / PART # | IMAGE   | DESCRIPTION                              | QTY / QTÉ |
|----------------|---|--|-----------|
| 11             |  | CONNECTING BRACKET<br>FIXATION D'ATTACHE | 1         |
| 12             |  | DESK TOP<br>SURFACE DU BUREAU            | 1         |

## LISTE DES PIÈCES DE MONTAGE HARDWARE LIST

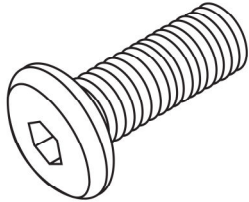
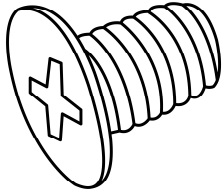
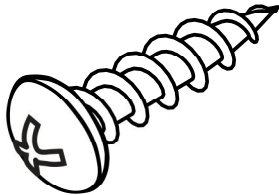
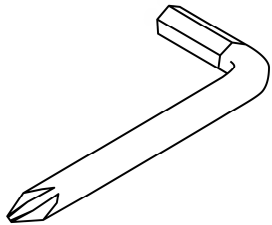
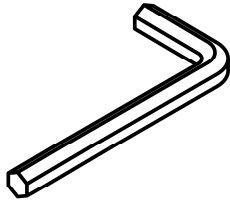
| PIÈCE / PART # | IMAGE   | DESCRIPTION  | QTY / QTÉ |
|----------------|---|--|-----------|
| <b>A</b>       |    | <b>ASSEMBLING BOLT -</b><br><b>1/4" X 3/8"</b><br><br><b>BOULON D'ASSEMBLAGE -</b><br><b>1/4" X 3/8"</b> | <b>28</b> |
| <b>B</b>       |    | <b>ASSEMBLING BOLT -</b><br><b>1/4" X 3/8"</b><br><br><b>BOULON D'ASSEMBLAGE -</b><br><b>1/4" X 3/8"</b> | <b>8</b>  |
| <b>C</b>       |  | <b>ASSEMBLING SCREW -</b><br><b>1/4" X 3/4"</b><br><br><b>VIS D'ASSEMBLAGE -</b><br><b>1/4" X 3/4"</b>   | <b>12</b> |
| <b>D</b>       |  | <b>HEX KEY</b><br><br><b>CLÉ HEXAGONALE</b>  | <b>1</b>  |
| <b>E</b>       |  | <b>HEX KEY</b><br><br><b>CLÉ HEXAGONALE</b>  | <b>1</b>  |



**OUTIL DE VÉRIFICATION DE DIMENSIONS DES PIÈCES  
HARDWARE DIMENSIONS VERIFICATION TOOL**



ÉTAPE / STEP 1

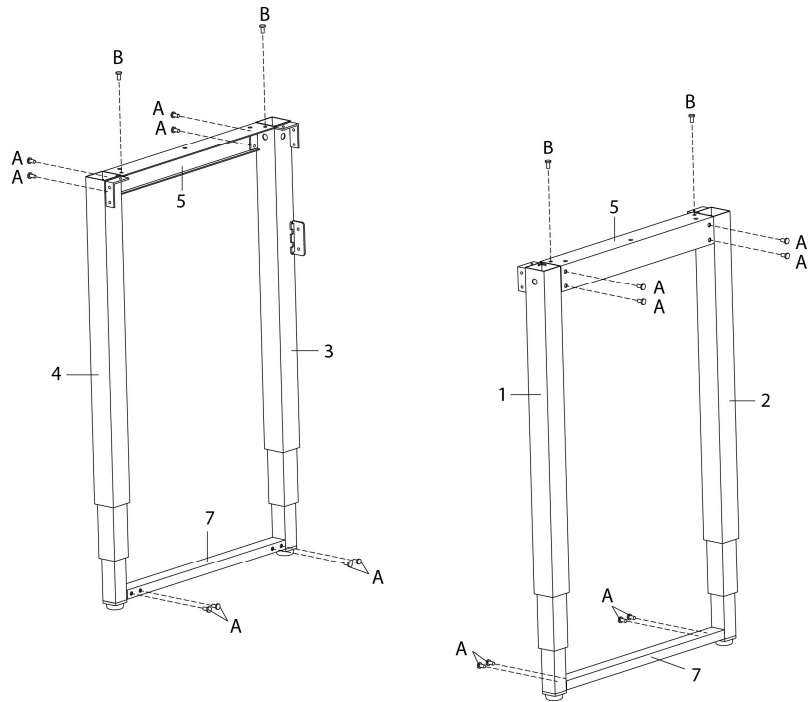

ÉTAPE / STEP 2

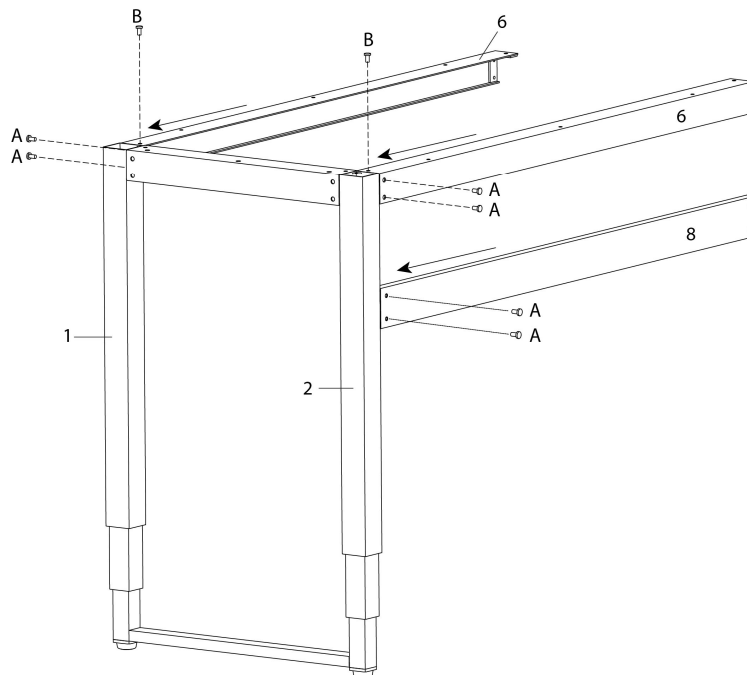

ÉTAPE / STEP 3

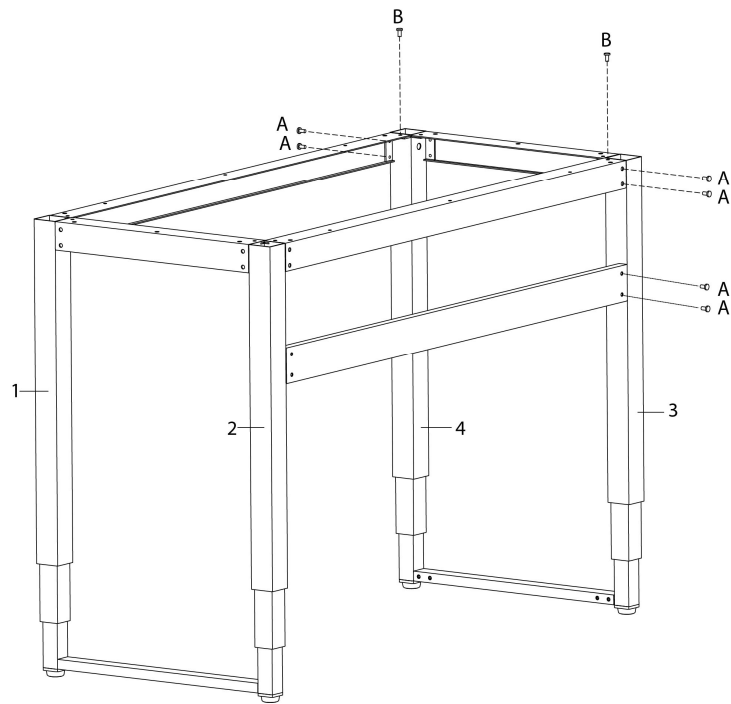

ÉTAPE / STEP 4

INSERT THE CONNECTOR INTO THE HOLE AND TIGHTEN  
INSERER LE CONNECTEUR DANS LE TROU ET SERRER

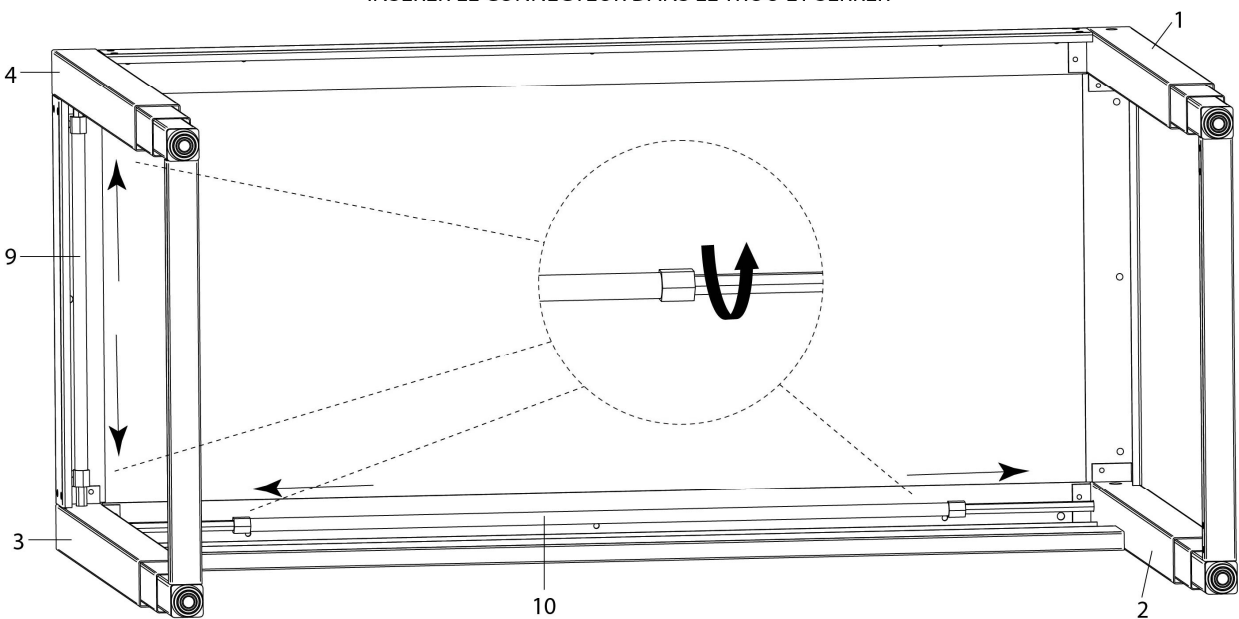

ÉTAPE / STEP 5

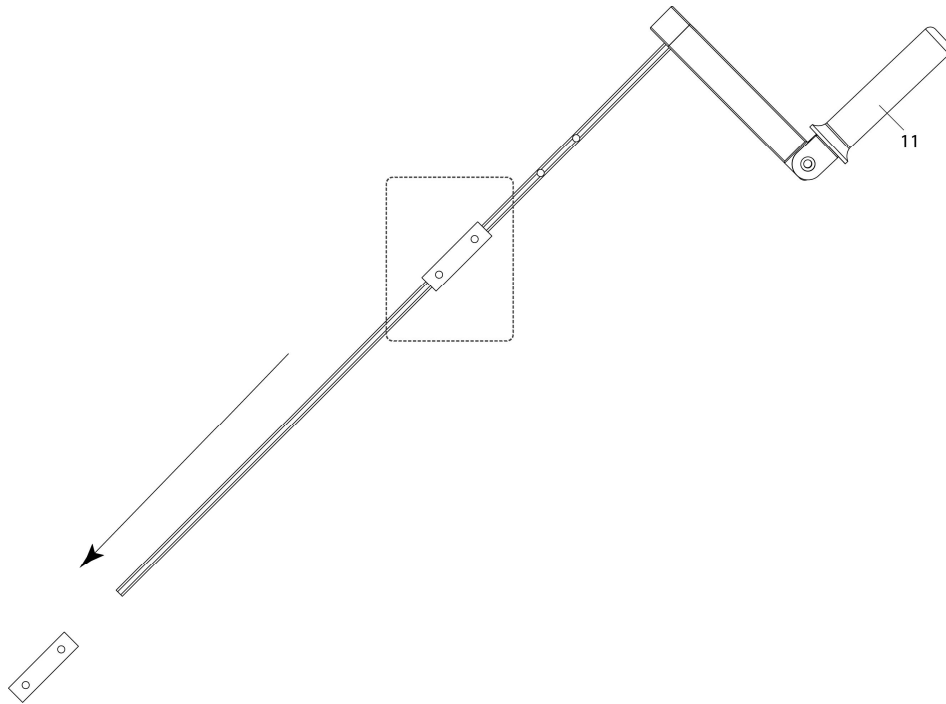

ÉTAPE / STEP 6

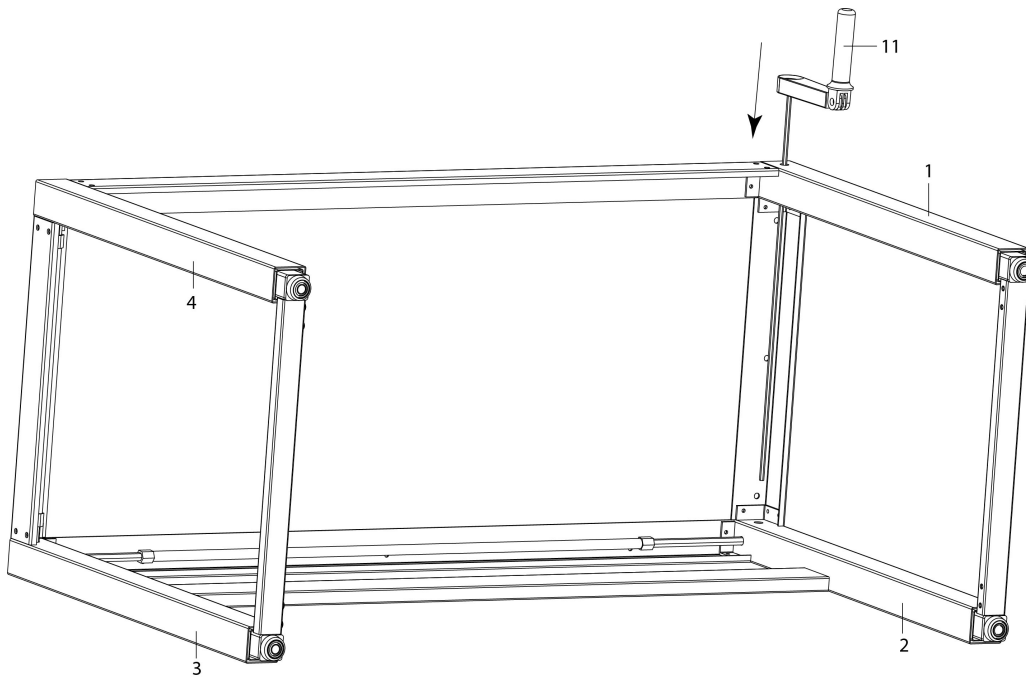

**ÉTAPE / STEP 7**

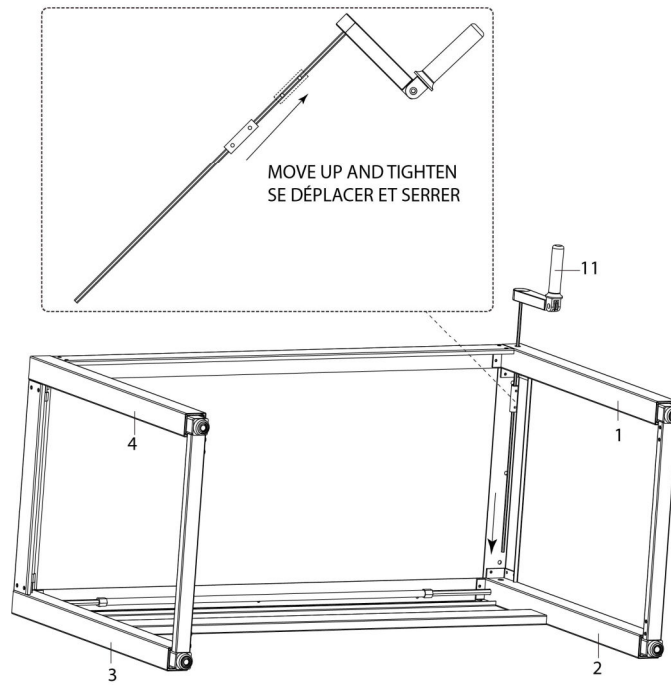

**ÉTAPE / STEP 8**

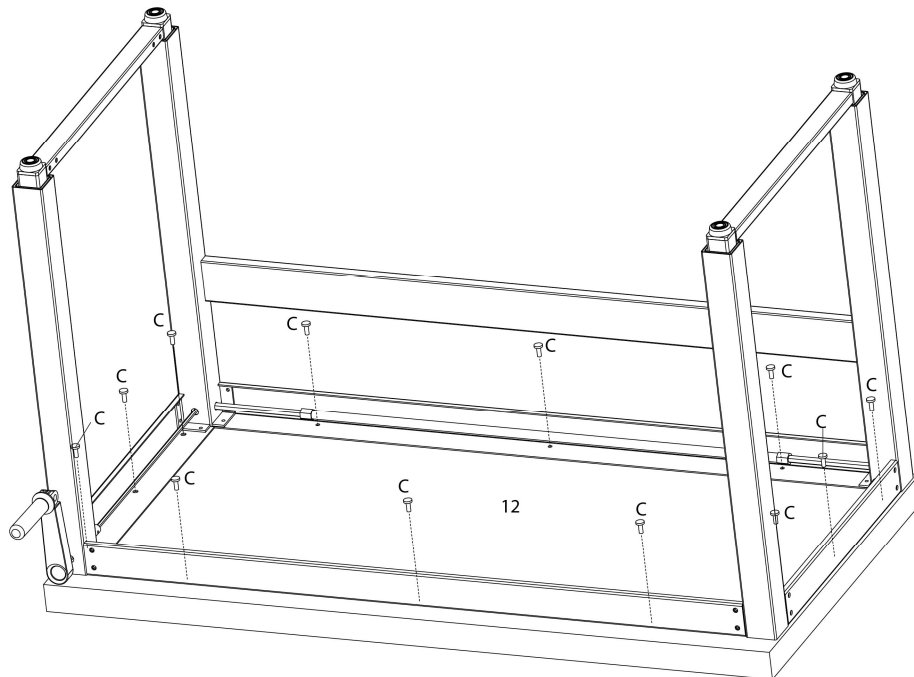

ÉTAPE / STEP 9

