

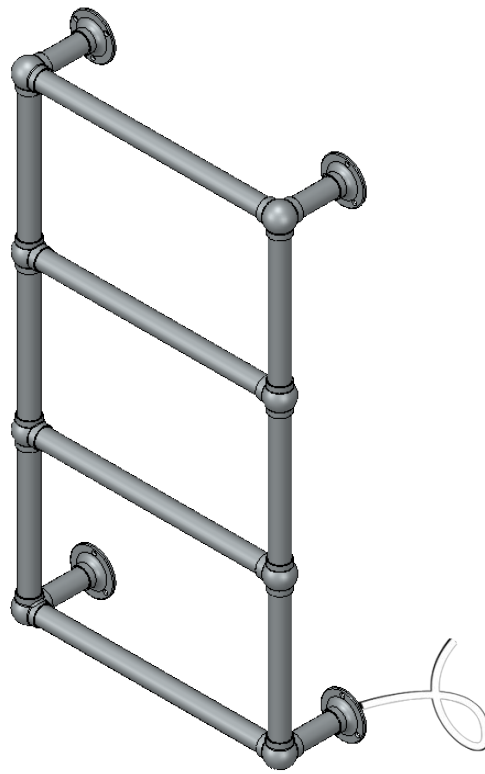

Handmade
in the heart of
BRITAIN



Stourton Electric 4 Rail

950 x 550 x 145

V1

02 August 2017

STOU-4-E-950-550-XX

UB - UNLACQUERED BRASS	CP - POLISHED CHROME
BB - BRUSHED BRASS	NP - POLISHED NICKEL
BN - BRUSHED NICKEL	LB - LIGHT BRONZE
LAB - LIGHT ANTIQUE BRONZE	MB - MEDIUM BRONZE
MAB - MEDIUM ANTIQUE BRONZE	DB - DARK BRONZE
DAB - DARK ANTIQUE BRONZE	GP - GOLD PLATED
AG - ANTIQUE GOLD	GM - GUN METAL
MWP - MATT WHITE P.COAT	MBP - MATT BLACK P.COAT

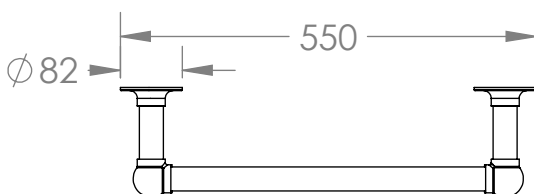
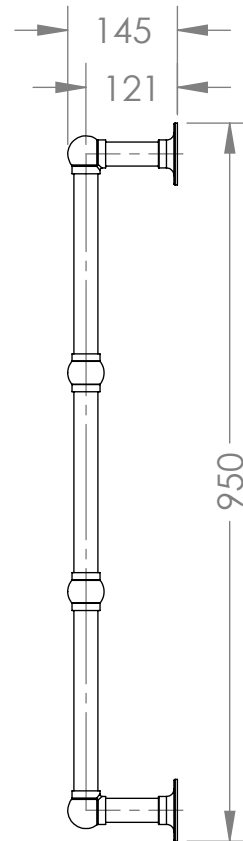
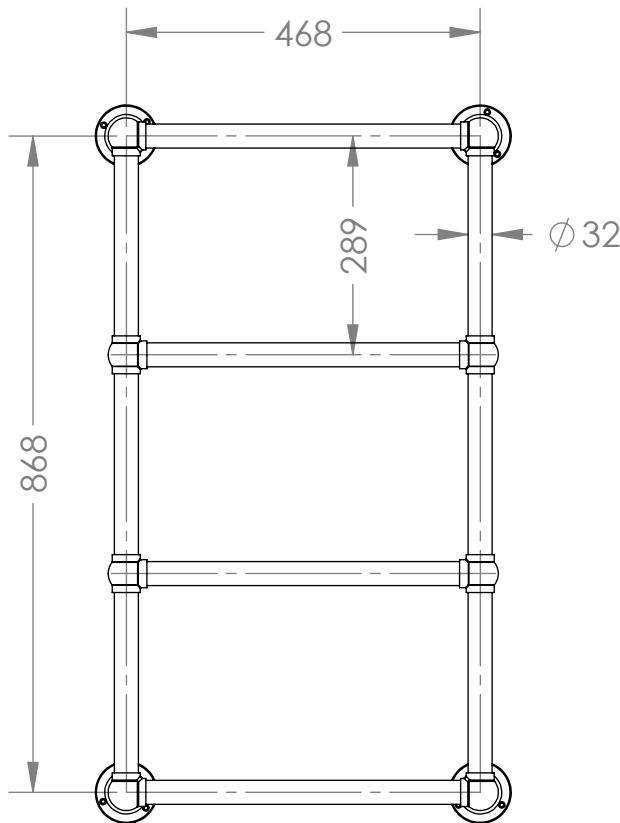

THE STERLINGHAM CO. LTD.

SCALE: 1:8

APPROX WEIGHT 6.51KG

MANUFACTURED FROM BRASS

Units 2 & 2A Stamford Street
Amblecote, Stourbridge,
Worcestershire
England, DY8 4HR

Telephone : 01384 370901
Fax : 01384 880159
sales@sterlingham.co.uk
www.sterlingham.co.uk

For Electric Towel Warmers:

Default cable exit is bottom right, 3m cable length - this can be modified, please state your requirements upon placing your order.