

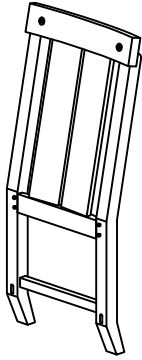





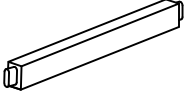
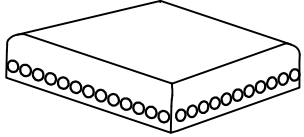
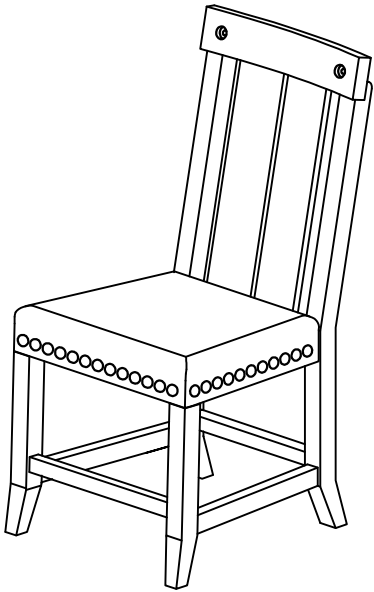

ASSEMBLY INSTRUCTIONS

<p>A. BACK FRAME 1 PC</p> 	<p>F. LEFT STRETCHER 1 PC</p> 	<p>G. RIGHT STRETCHER 1 PC</p> 
<p>B. SEAT FRAME 1 PC</p> 	<p>STOOL ASSEMBLED</p> 	
<p>C. FRONT STRETCHER 1 PC</p> 		
<p>D. LEFT LEG 1 PC</p> 		

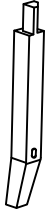
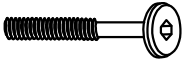
HARDWARE ENCLOSED IN BOX

<p>1 ALLEN BOLT M6 x 50 MM 04 PCS</p>	<p>2 ALLEN BOLT M6 x 70 MM 04 PCS</p>	<p>3 SPRING WASHER M9/11 8 PCS</p>	<p>4 WASHERS M9/22 8 PCS</p>	<p>5 ALLEN KEY N4 01 PC</p>
				
<p>6 SCREW M4 x 40 MM 6 PCS</p>				
				

TOOL REQUIRED

PHILLIPS HEAD SCREW
DRIVER NOT PROVIDED

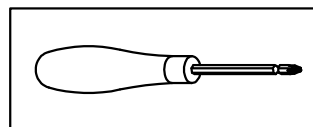

STEP 1:

Insert 2 legs (D),(E) and front stretcher (C) to seat frame (B). Connect with bolt (1) flat washer (3) and spring washer (4).

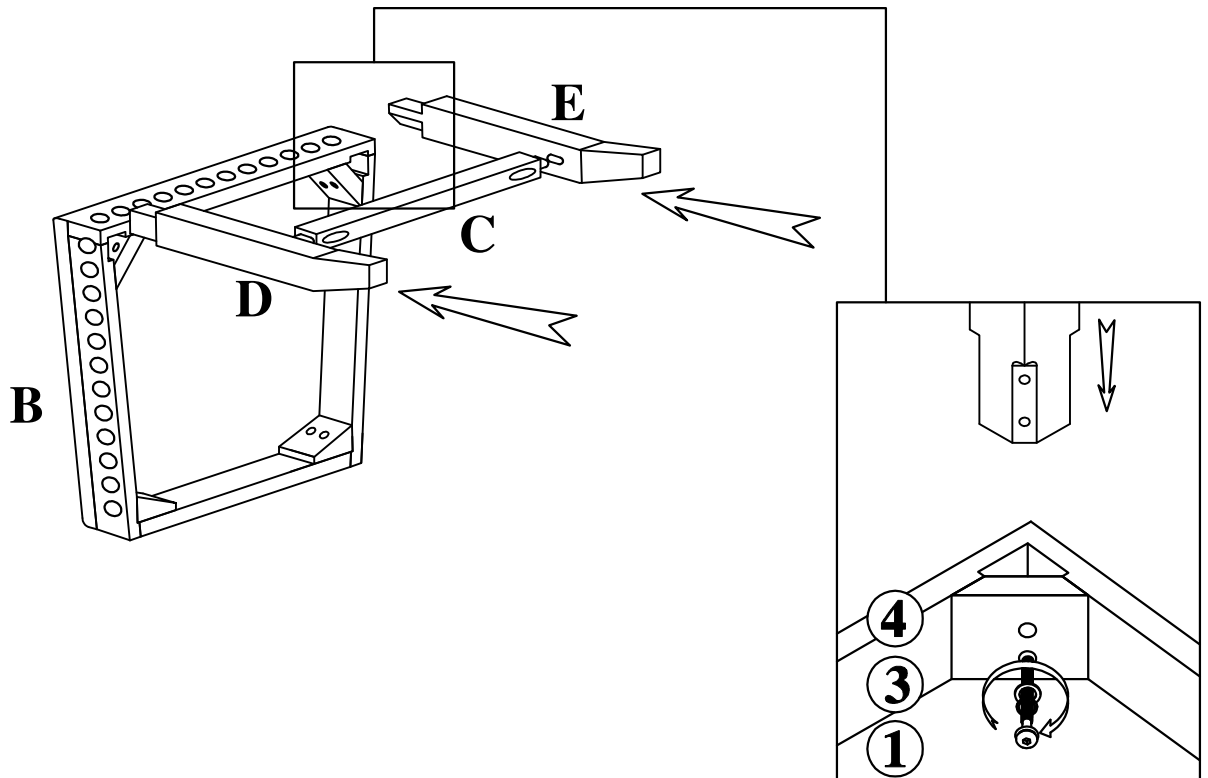

STEP 2:

Attach the stretchers (F)&(G) to the back frame (A).

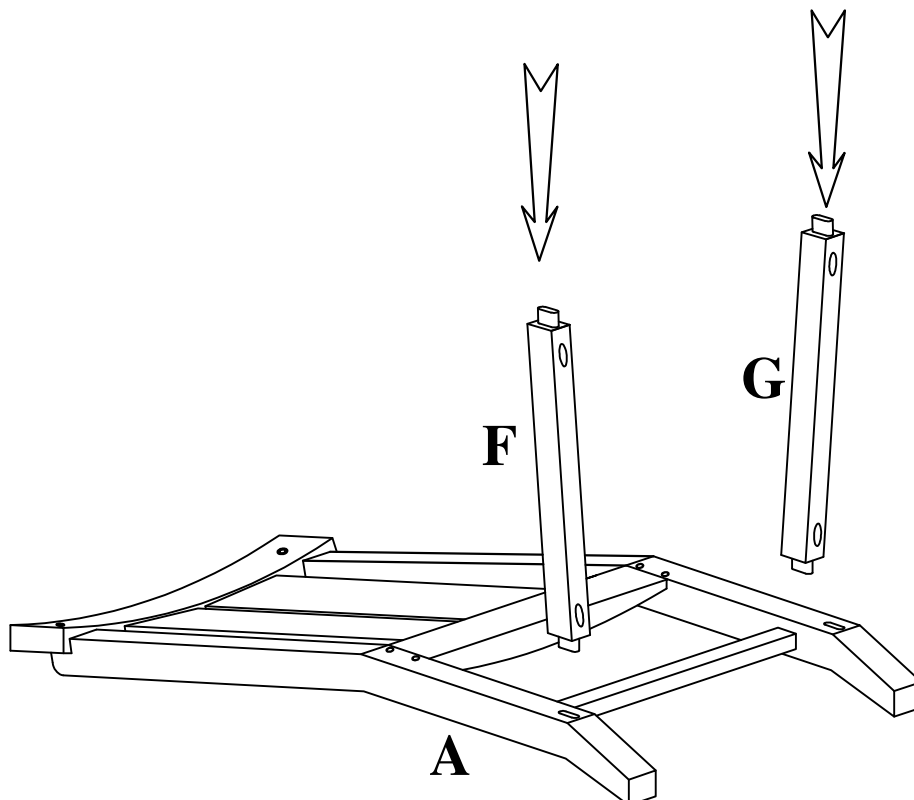

STEP 3:

Connect seat frame with bolt (2), washer (3) and spring washer (4).

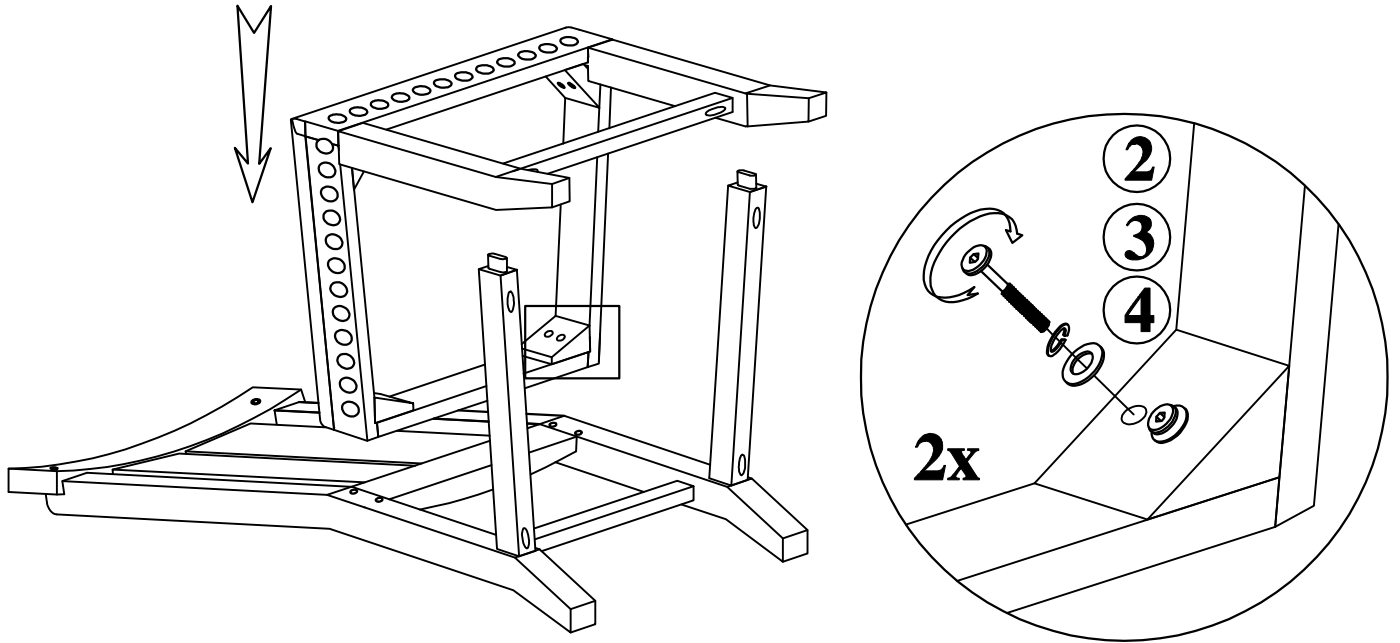

STEP 4:

Connect stretchers with screws (6).
Assembly complete.

