

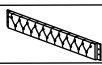









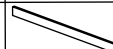
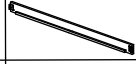

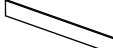
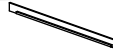





ASSEMBLY INSTRUCTION

ITEM : 50005

NO	PART LIST		QTY
1		BACK REST	1PC
2		SIDE PANEL (L)	1PC
3		SIDE PANEL (R)	1PC
4		FRONT SIDE RAIL	1PC
5		BACK SIDE RAIL	1PC
6		LEG	4PCS
7		SLAT	2 SET
8		TRUNDLE FRONT RAIL	1PC
9		TRUNDLE BACK RAIL	1PC
10		TRUNDLE SIDE RAIL	2PCS
11		SLAT	2 SET
12		SLAT	3PCS
13		CASTOR	6PCS
ITEM	HARDWARE		QTY
A		JCBB SCREW M8 x 20MM	16PCS
B		JCBC SCREW M6 x 50MM	20PCS
C		SPRING WASHER M6 x 13MM	16PCS
D		FLAT WASHER M6 x 19MM	4PCS
E		FLAT WASHER M6 x 13MM	12PCS
F		SCREW M4 x 16MM	24PCS
G		SCREW M4 x 32MM	16PCS
H		L - KEY M4 x 65MM	1PC
I		L - KEY M5 x 65MM	1PC

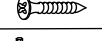
STEP 1

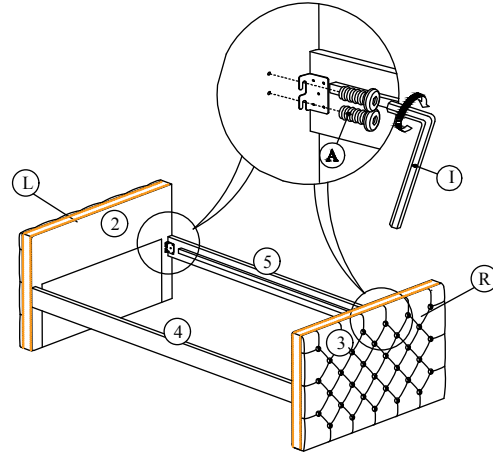

STEP 2

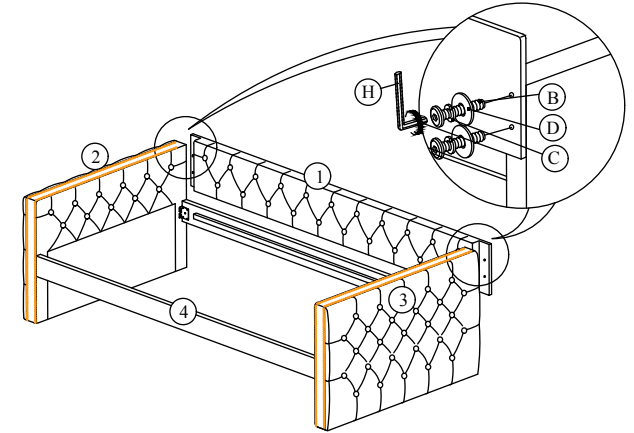

STEP 3

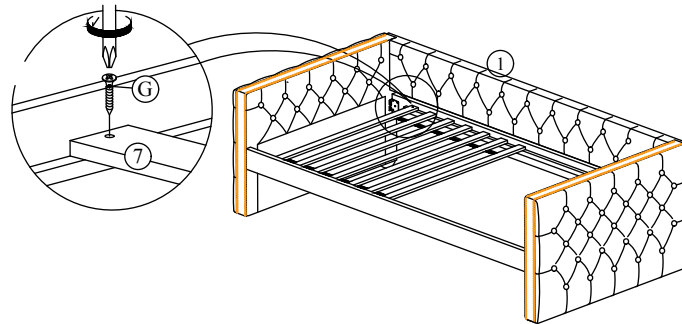

STEP 4

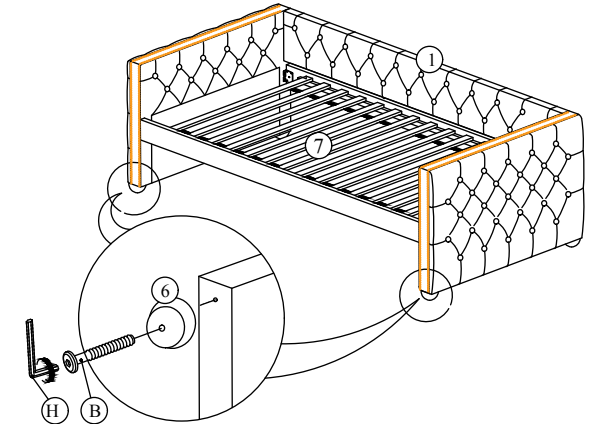

STEP 5

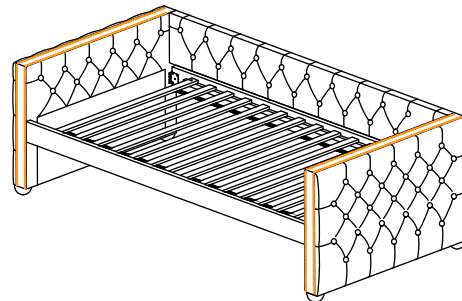

STEP 6

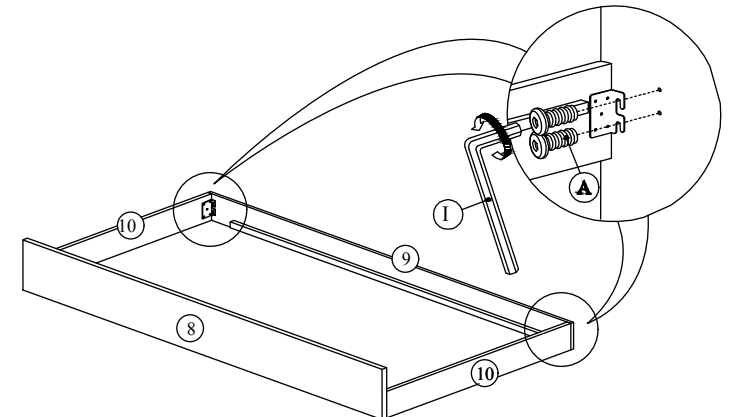

ASSEMBLY INSTRUCTION

STEP 7

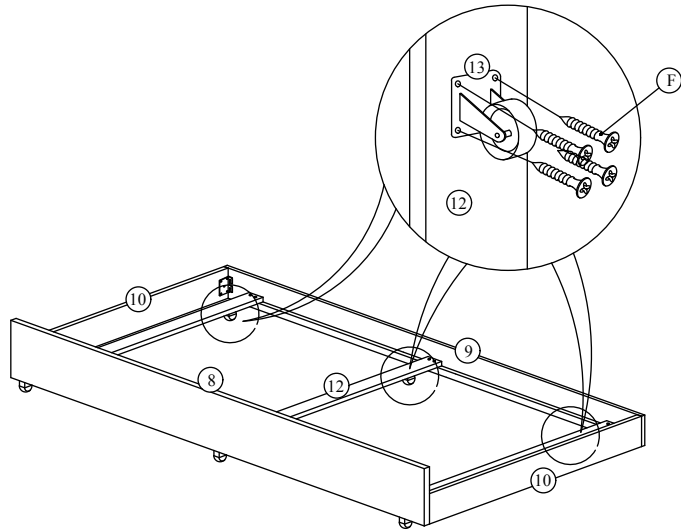

STEP 8

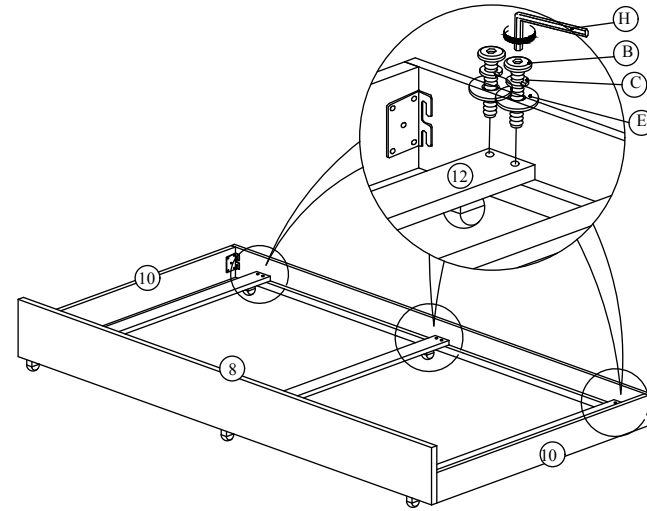

STEP 9

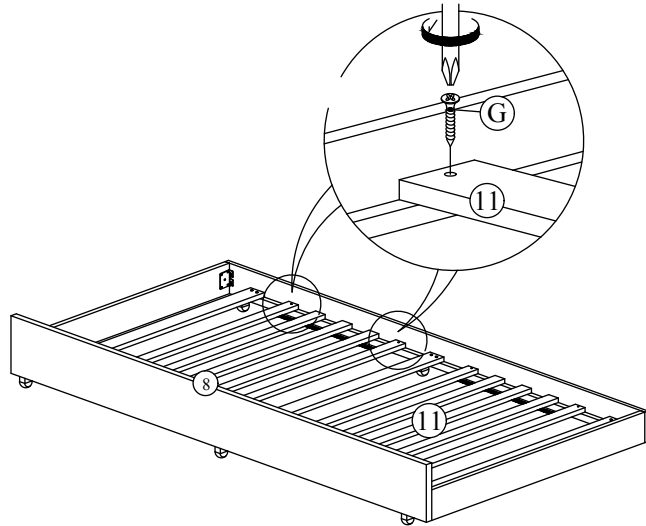

STEP 10

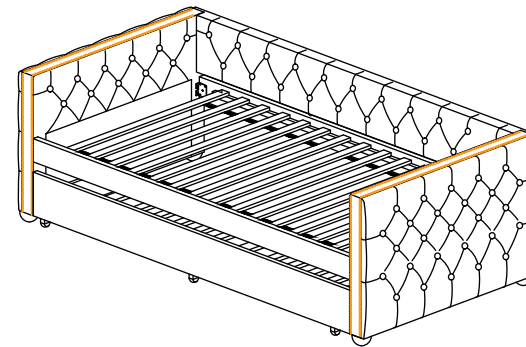

ASSEMBLY
COMPLETE

Please do not tighten the hardware until the entire assembly is completed.