

Please check contents **before** assembly. If any items are missing or damaged, **do not take the unit back to the store.**

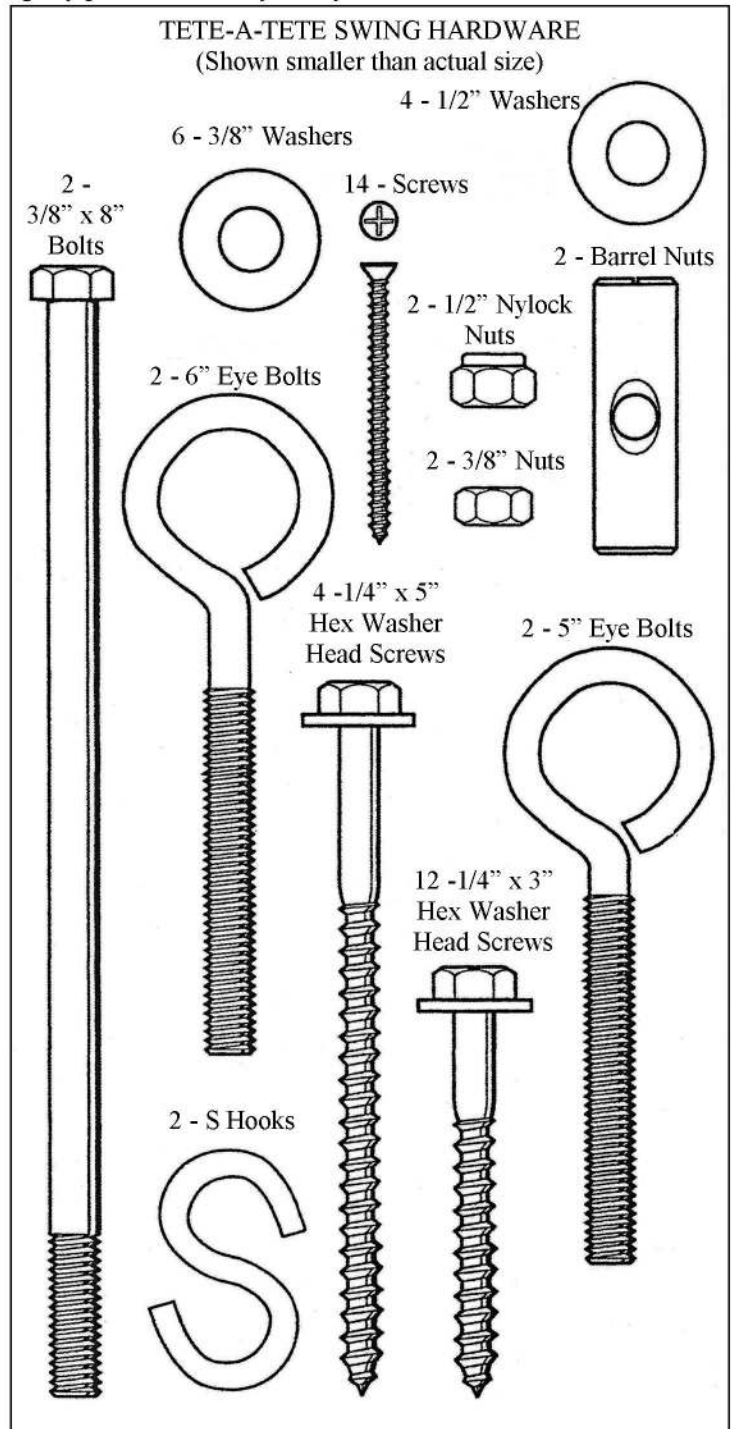

NOTE:

- Read all instructions before starting.
- Helpful Tips:**
- To start hex washer head screws, hammer into wood about 1/2" then use wrench or socket to tighten.
- Do not completely tighten any screws until the unit is fully assembled and setting on a level surface.
- If you have hardware left over after completing your unit, it most likely has been assembled incorrectly, and may not be safe to use. Please call
- **Check all nuts and bolts for tightness before and during each usage season.**

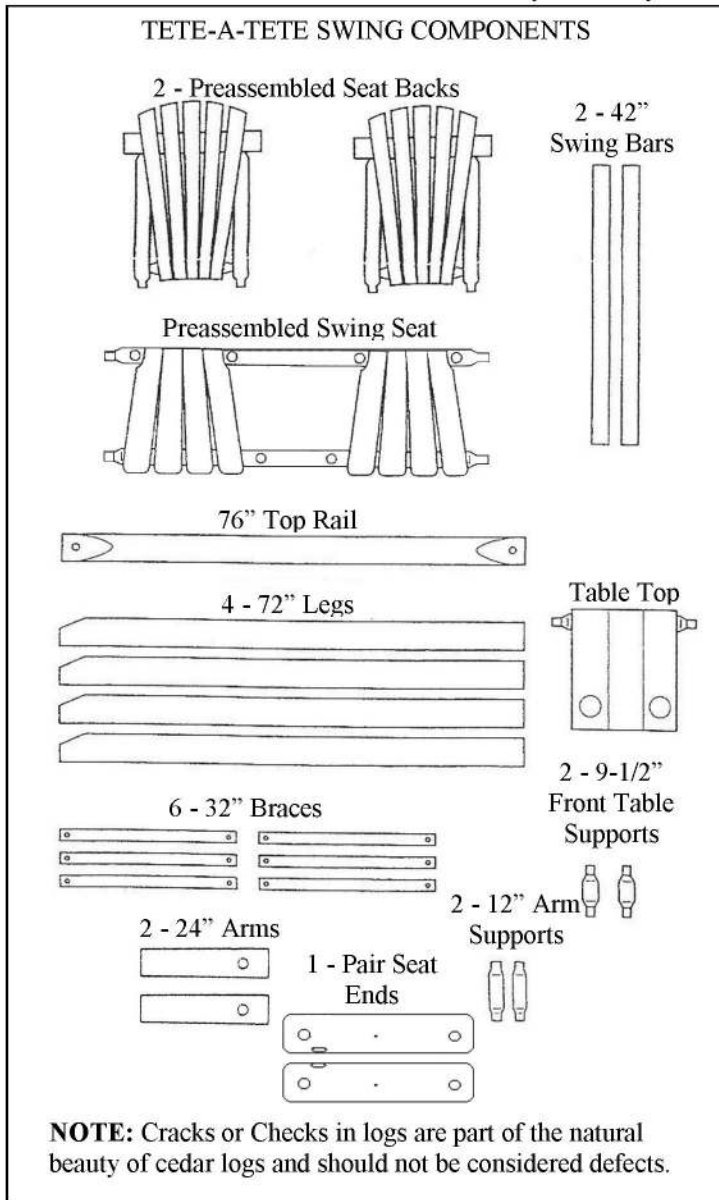
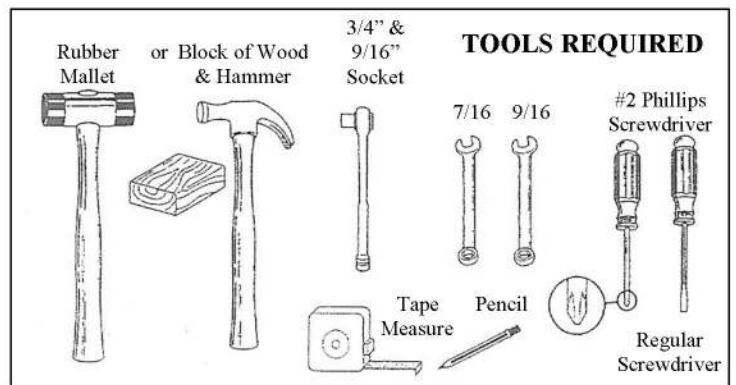

FRAME ASSEMBLY

STEP 1 See figure 1A. Place a 1/2" washer on the 6" eye bolt. Drive the eye bolt through the hole in top rail, on the opposite side from the counterbore. Place 1/2" washer on the 6" eye bolt in the counterbore, then place nylock nut on the eye bolt in the counterbore. Tighten with 3/4" socket. Repeat this process on the other side. See figure 1B Lay top rail on the ground with eye bolts down. Lay top of legs parallel to top rail as shown in figure 1B and attach all legs with 8" bolts, 3/8" washers, and nuts, using a washer on both ends of the bolt. Repeat process on opposite side. **DO NOT TIGHTEN YET.**

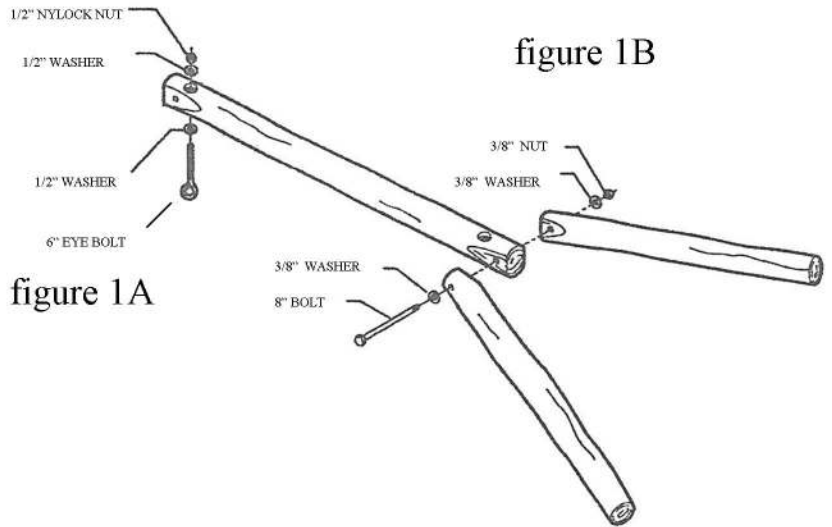

STEP 2 Pre-measure and mark rail and legs for braces. Mark position of leg braces 30" from the top of the legs as illustrated in figure 2. Mark position of rail to leg brace 19" from the end of top rail and 24" from the top of legs as shown in figure 2.

This will set your swing seat at an average height from the ground. If you wish to raise the seat higher, attach leg braces more than 30" from the top of the legs. To lower the seat height, attach them at a point less than 30" from the top of the legs.

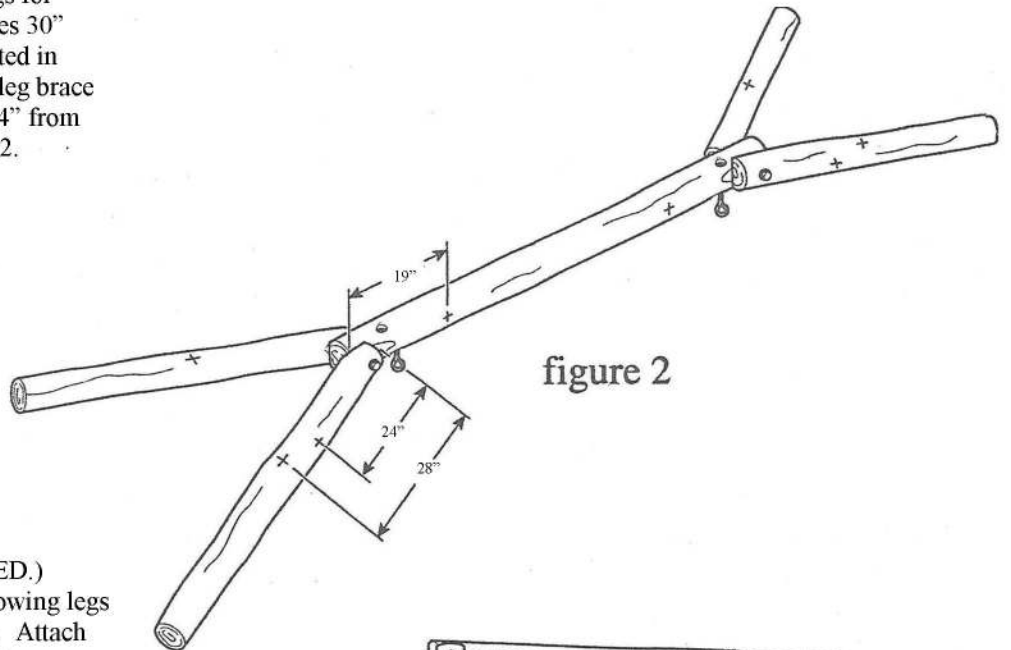

STEP 3 (TWO PEOPLE RECOMMENDED.) Lift top rail with legs attached allowing legs to swing into position underneath. Attach braces (as illustrated in figure 3) to pre-marked positions tapping 3" hex washer head screws with a hammer to start them into legs and tightening them with a 7/16" wrench. After all 6 braces are attached and frame is setting on firm level surface, tighten them securely. Now tighten the nuts and bolts that attach the legs to the top rail with 9/16" wrench, making sure bolts are **TIGHT**.

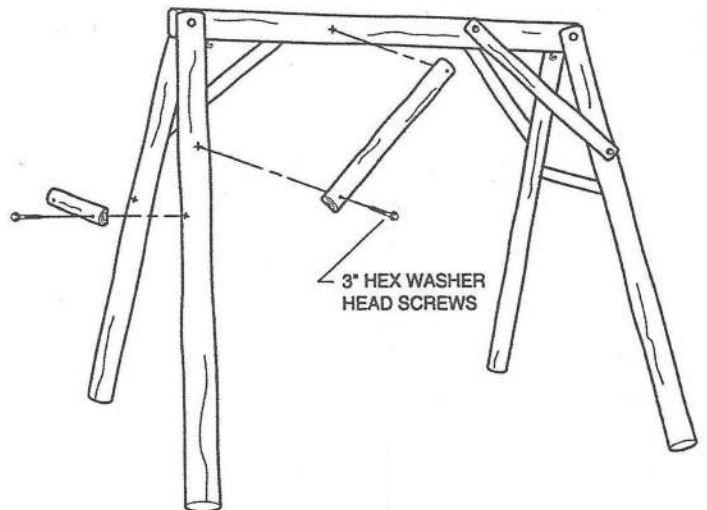

figure 3

STEP 4a Install seat end onto seat. Align holes in seat end with dowels on seat as shown in picture right. Repeat on other side. Secure with screws perpendicular to dowel. **IMPORTANT:** The single hole should be placed toward the front for the seat. (See below).

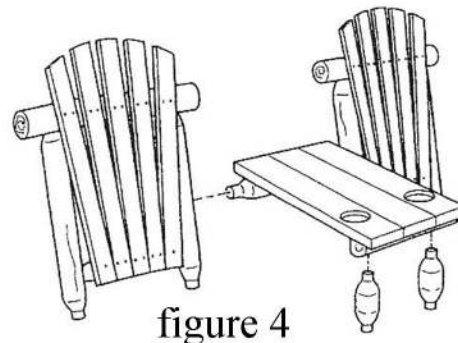
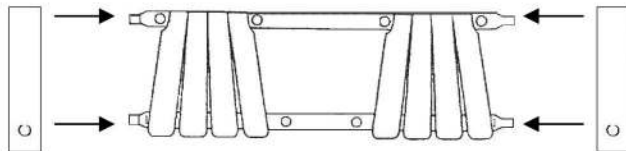

figure 4

STEP 4 Assemble front table supports into table top and back table support into seat backs as shown in figure 4.

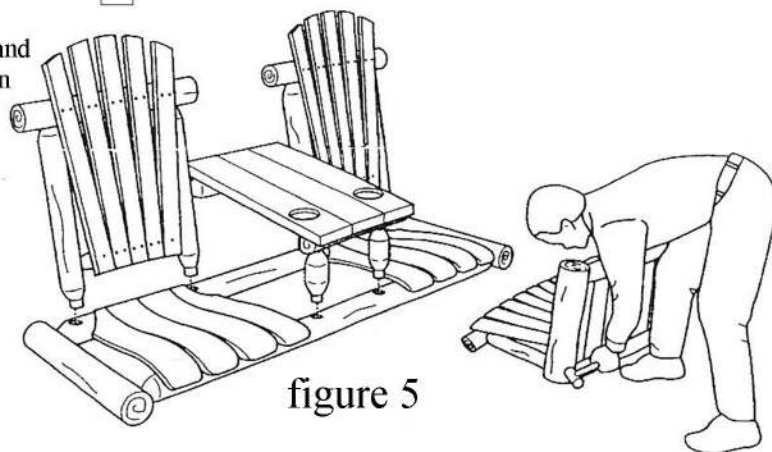

figure 5

STEP 5 Lay assembled seat on ground. Insert dowel end of uprights on assembled seat back into 1-1/4" holes on the back seat rail, adjusting uprights in or out as needed to align properly. Align front table supports into holes on front of seat rail. Do not tap on seat back with hammer.

To keep the SEAT RAIL from splitting, lay the back on the ground and drive the seat on by hitting on the bottom of the seat assembly.

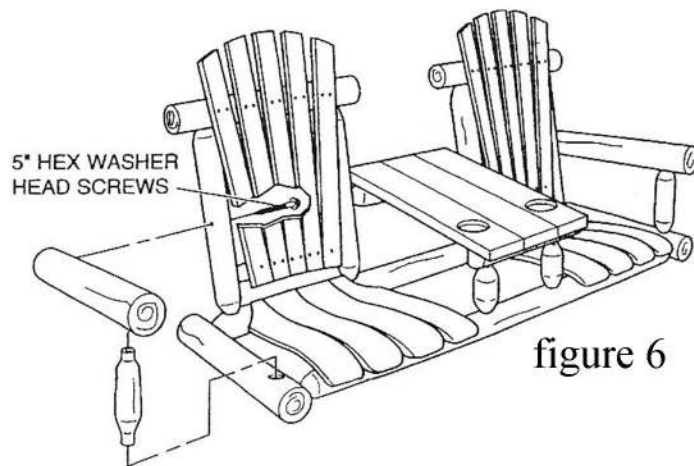

figure 6

STEP 6 Insert 12" arm support into hole in arm, then into hole in the top of the seat end. Drive the dowels in as far as possible.

Fasten arm to frame **from the back** by tightening the preinstalled lag screw into the pilot hole in the arm with a 7/16" wrench. Repeat the process for the other arm.

STEP 7 Secure all **dowel joints that you have assembled** in place with screws perpendicular to the doweled end as shown in figure 7.

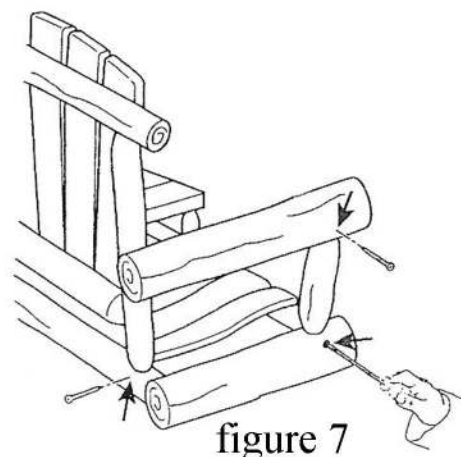
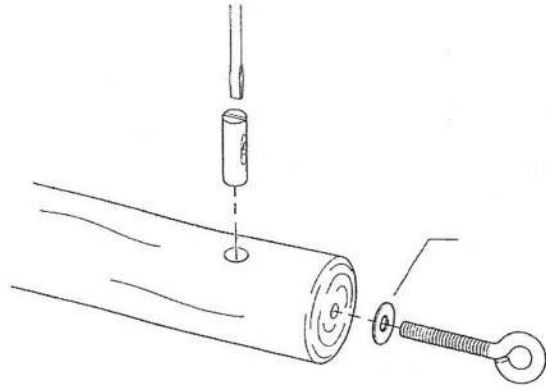
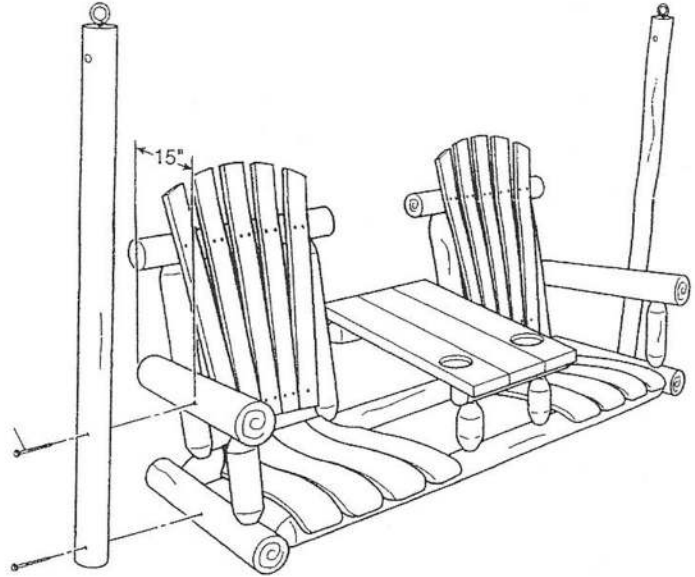

figure 7

- STEP 8 Put barrel nut into horizontally drilled hole in end of swing bar. Position barrel nut with screwdriver and screw in 5" eyebolt with 3/8" washer as shown in figure 8. **TIGHTEN DOWN SECURELY!** Repeat process for other swing bar.



- STEP 9 Fasten swing bars to side of unit as shown in figure 9. With hammer tap a 5" hex washer head screw through the bottom hole in swing bar and into pilot hole on seat end. Tap a 5" hex washer head screw through the upper hole in the swing bar and into the arm about 1.2" deep at the point of 15" from the back of the arm. (This gives a suggested pitch of the seat. You may change the pitch by altering the location of the lag screw in the arm. Tighten down lag screws.



SEAT TO FRAME ASSEMBLY

- STEP 10 Place the 'S' hooks onto the eye bolts on the top rail of the swing frame. Place eye bolts of the swing bars onto the 'S' hook in the top rail.

- STEP 11 Tighten all lag screws firmly. Your unit is now ready for finishing or immediate use. Relax and enjoy.

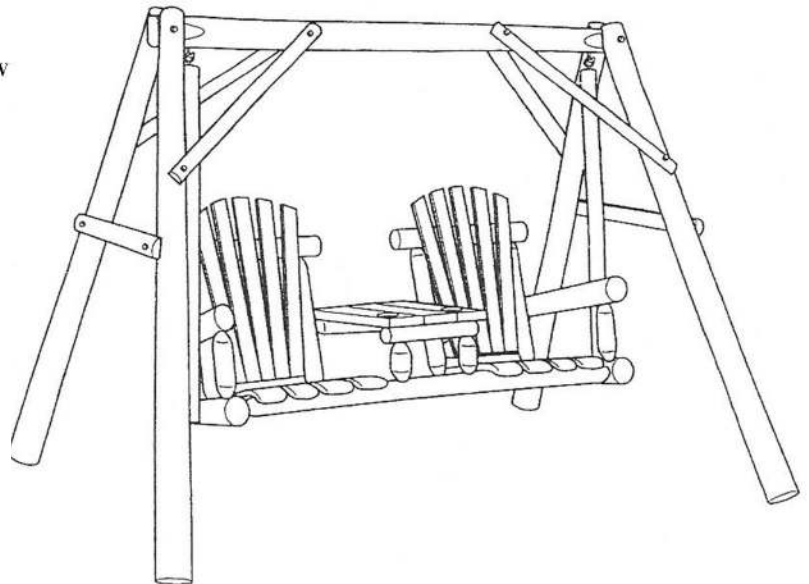

NOTE: Check all nuts and bolts for tightness before and during each usage season.