

SHELF RELIANCE

ASSEMBLY INSTRUCTIONS

Pantry Organizer

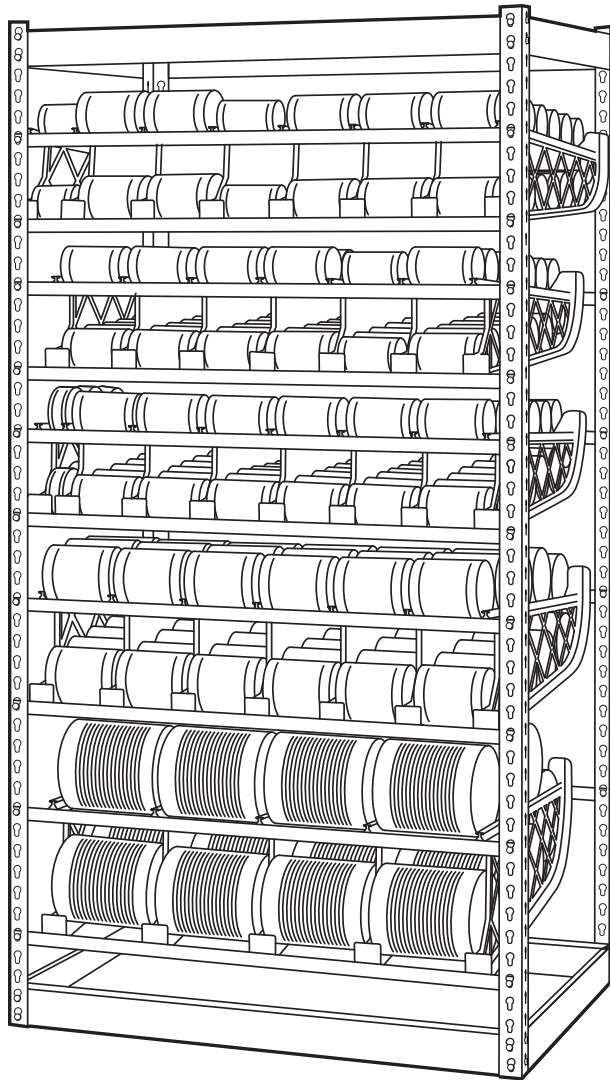

Note: The picture used in the assembly instructions is a general picture of a Pantry Organizer. Although your system may vary in size and dimension, these instructions are suited for all Pantry Organizers.

For assembly video and support visit shelfreliance.com

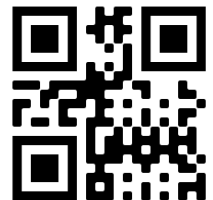

PANTRY ORGANIZER

Assembly Instructions



For assembly video,
visit shelfreliance.com

Tools needed

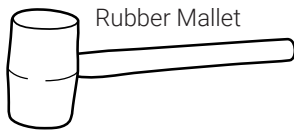

Rubber Mallet

Use a hard rubber mallet to pound metal pieces together. We do not recommend using a hammer. It may leave dents and chips in the paint.

Parts See the parts list on page 6 for the exact number of each part that comes with your unit.

Large Can Track

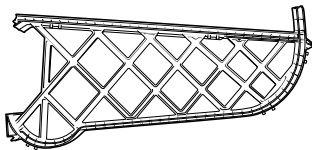

Medium Can Track

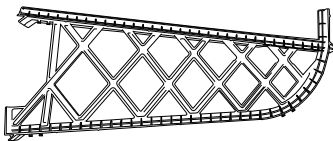

Small Can Track



Double Rivet Beam (DRB) (long 36")

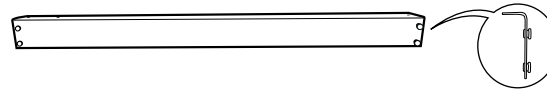

Double Rivet Beam (DRB) (short 24")



Single Rivet Beam (SRB) or Crossbar (36")

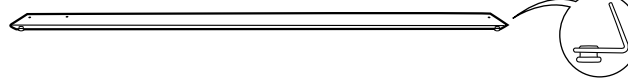

Strap

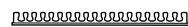

Angle Post (75")

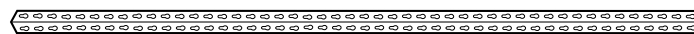

Tips

1. **Storage area.** To optimize food shelf life, set up your Pantry Organizer in a cool area that experiences few temperature fluctuations and remains in the range of 40–70°F.
2. **Assembly.** Assemble the unit on a sturdy, level surface. Safe assembly requires at least two people.
3. **Connecting metal pieces.** Pound SRB's and DRB's into angle posts with a mallet until the rivets have firmly set into the bottom of the notches. This is important to ensure maximum stability of the frame and proper fit of Can Tracks.



4. **Notches** are the cutout keyhole segments of an angle post.



5. **Rivets** are the 1/4" protruding round buttons that insert into the notches.



6. **Lips** are the horizontal edges of SRB's and DRB's. The DRB's on the top of the unit should have the lips on the bottom (as shown in this image). The DRB's on the bottom of the unit should have the lips on the top.



Caution: Failure to pound down all DRB's and SRB's so the rivets are set firmly into the bottom of the notches may cause the unit to tip over and could result in serious injury.

PANTRY ORGANIZER

Assembly Instructions



For assembly video,
visit shelfreliance.com

Building your frame

Caution: Your Pantry Organizer must stand on a level, solid surface.

Your Pantry Organizer may scratch or damage tile, linoleum, wood, and other fine surfaces. To help avoid floor surface damage, we recommend using furniture sliders, which you can purchase at home improvement stores or on amazon.

Leave enough room behind your Pantry Organizer during setup to walk behind it and attach straps. After assembly, your Pantry Organizer can be backed up against a wall before loading with cans.



IMPORTANT:
For maximum stability,
pound down on DRB's until
rivets are secure in bottom
of notches.

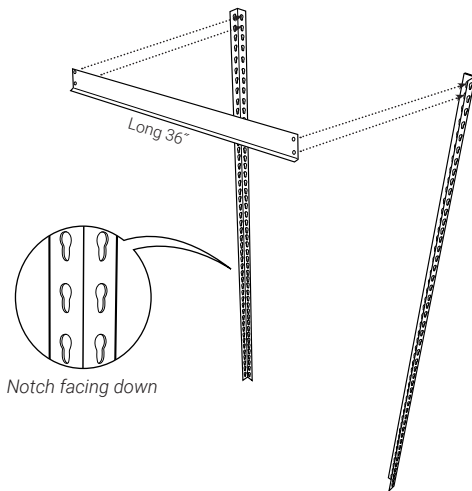

Step 1

Stand 2 angle posts upright. Attach a long DRB to the top two notches of angle posts with the lip on bottom facing inward.

Note: Depending on the system you ordered, you may have 3 extra SRB's. These can be discarded.

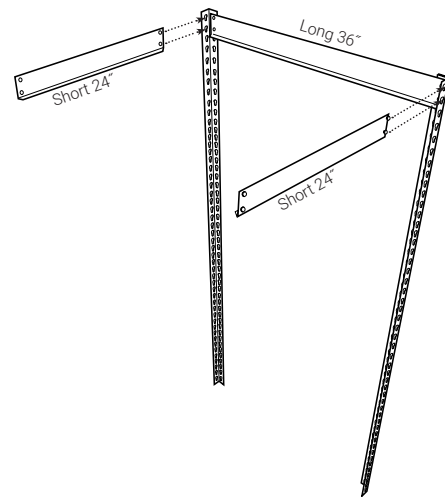

Step 2

Attach a short DRB to the top notches of each angle post.

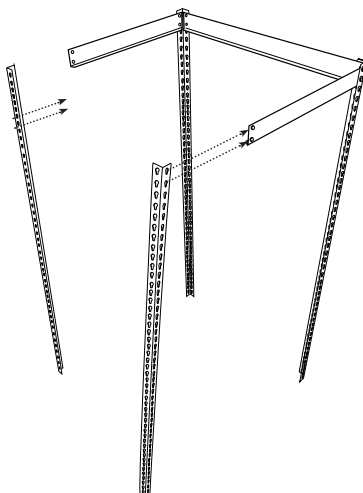

Step 3

Attach remaining angle posts.

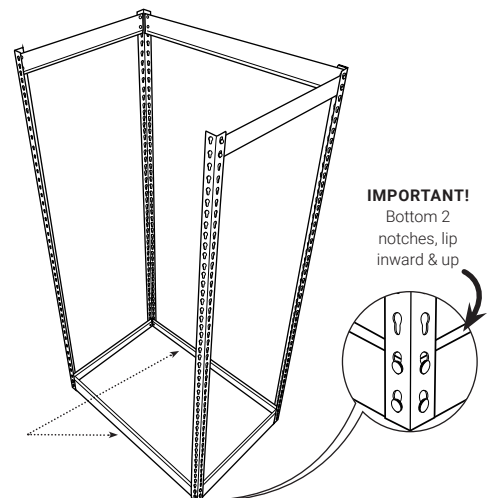

Step 4

Attach short & long DRB's to angle posts in the bottom 2 notches. This time, the lip should be on top, facing inward.



Attaching your Single Rivet Beams (Crossbars)

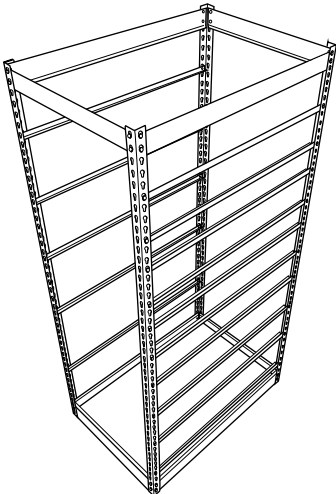

Step 5

Attach the crossbar SRB's (lip on bottom facing inward) to the front and rear side of the frame in the following notches (**counting from the bottom up**).

Model	Rows	Height x Width x Depth	Front SRB's	Rear SRB's
Family Size Can System	4 Large	75" x 36.5" x 24.5"	4, 10, 15, 21, 26, 32, 37, 43	9, 20, 31, 42
Pantry Can System	5 Medium	75" x 36.5" x 24.5"	4, 9, 13, 18, 22, 27, 31, 36, 40, 45	8, 17, 26, 35, 44
Variety Can System	2 L / 1 M / 2 S	75" x 36.5" x 24.5"	4, 10, 15, 21, 26, 31, 35, 39, 42, 46	9, 20, 30, 38, 45

Step 6

Attach the remaining DRB to the front side of the frame in the top two notches on the angle posts.

Putting in your Can Tracks

Step 7

Attach Can Tracks to the frame. Depending on which configuration you purchased, you may have one, two, or all three sizes of Can Tracks.

If your unit has different sizes of Can Tracks, put the large Can Tracks on the bottom, medium Can Tracks in the middle, and small Can Tracks on the top.

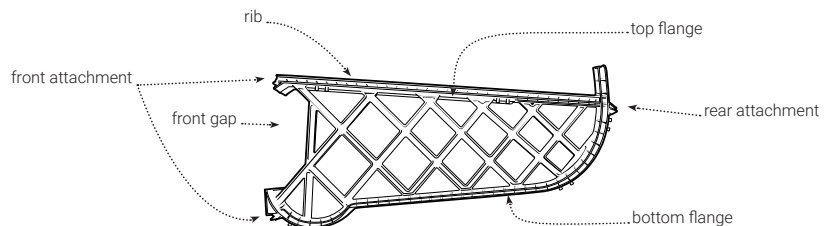

Each Can Track will attach to 3 SRB's—2 on the front and 1 on the rear.

Attach all Can Tracks using these steps:

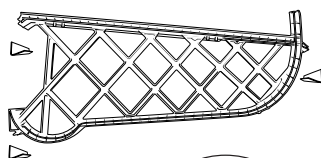

1. Start on the bottom 2 front SRB's and hold the front attachment of the Can Track so that it straddles the upper SRB.

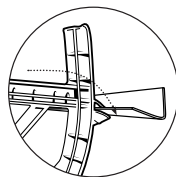

2. Insert the rear attachment into the rear SRB.

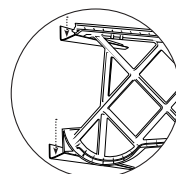

3. Press the front attachment of the Can Track downward into the front SRB



Putting in your Can Tracks (continued)

Step 8

Adjust Can Tracks to the desired width using the following steps:

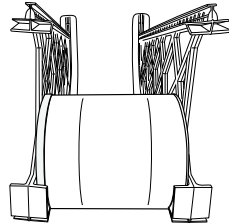

1. Place a can on the bottom flanges of two Can Tracks.

Note: Small, medium, and large Can Tracks each store different sizes of cans. It is important that cans are rotated in the correct Can Tracks to prevent them from binding (getting stuck) in the back. The can sizing diagram on page 8 will help you determine the appropriate can size.

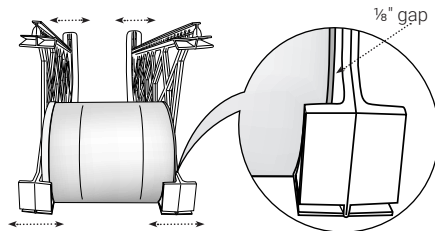

2. Adjust the width of the Can Tracks so that the can rests about $\frac{1}{8}$ " away from the center rib of the Can Track on each side.

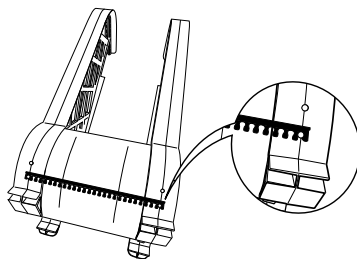

3. Secure the width by attaching a strap to the buttons on the bottom of the Can Tracks. Position the strap so that the lip is perpendicular to the Can Tracks, allowing you to push the lip of the strap forward until the strap snaps into place. Flat side of the strap goes against can track.

Large Can Track button sets

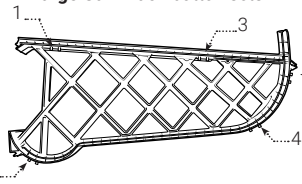

Medium Can Track button sets

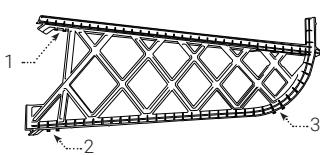

4. Attach additional straps to the remaining button sets (shown at the left) at the same increment as the first strap.

Small Can Track button sets

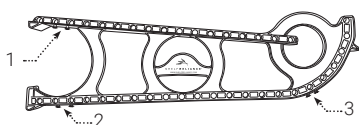

5. Connect adjacent Can Tracks by alternating straps between the top and bottom sets of buttons, as shown here.

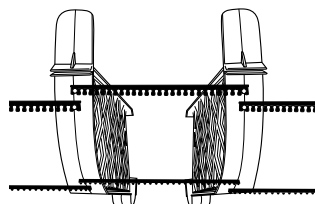

PANTRY ORGANIZER

Assembly Instructions



For assembly video,
visit shelfreliance.com

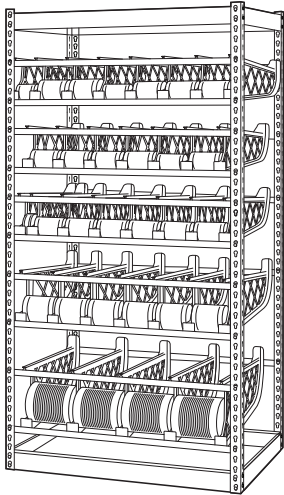

Finished Pantry Organizer

Congratulations!

You've finished assembling your Pantry Organizer and are ready to easily store and automatically rotate your canned goods.

For support visit shelfreliance.com

Troubleshooting

Can rolling

Cans should roll smoothly. If they don't, or if a can falls in between two Can Tracks, check to see that all straps on the track are attached to the buttons at the same increment to create equal spacing in front and back. Dirty or dusty tracks may also prevent cans from rolling smoothly. Cleaning the "flange" or surface on which cans roll can help.

Can binding

If a can binds (gets stuck) in the back, double-check the Can Sizing Diagram to see if the can is in the right size Can Track. Then check the straps to ensure they are attached at the same increment in the front and back. Finally, give the can a gentle push to engage the rolling process.

Defective or missing parts

If there are defective or missing parts when you receive your Pantry Organizer, visit shelvingsupport.com.

Parts List

	Dimensions (H x W x D)	Row Configuration	Angle Post	Double Rivet Beams (DRB)		Single Rivet Beam (SRB)	Can Tracks			Straps
				36"	24"	36"	L	M	S	
Pantry Organizers										
Pantry Can	75"x36.5"x24.5"	5 Medium	4	4	4	15		30		100
Family Can	75"x36.5"x24.5"	4 Large	4	4	4	12	20			
Variety Can	75"x36.5"x24.5"	2L / 1M / 2S	4	4	4	15	10	6	14	

PANTRY ORGANIZER

Assembly Instructions



For assembly video,
visit shelfreliance.com

Can sizing diagram

The circles below represent various can sizes. To determine which Can Track to use, place can right side up in the center of the chart. The closest visible line to the edge of the can indicates which Can Track to use.

