

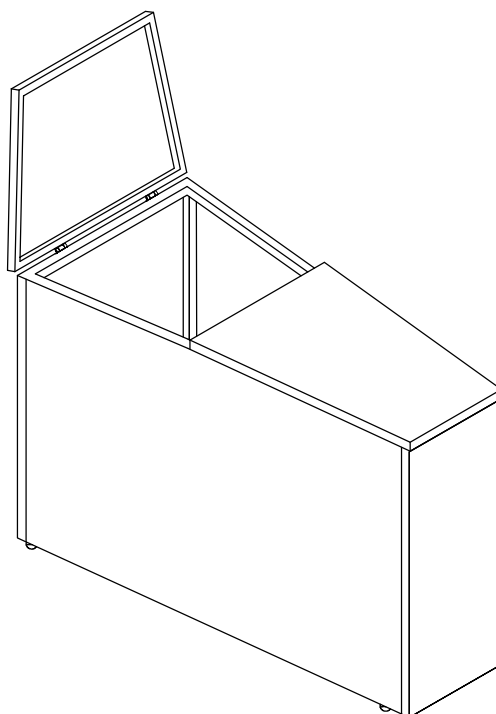

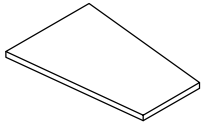

Catalina Outdoor Wicker Round Sectional Arm Table

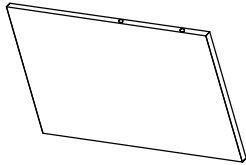

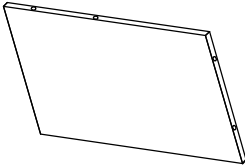

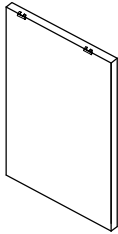
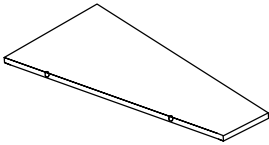
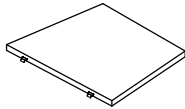
PART LIST

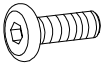
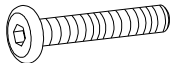
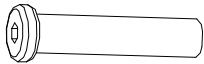
 Long Wicker Top		 Right Side Panel			
A	1PC	B	1PC		
 Left Side Panel		 Front Panel			
C	1PC	D	1PC		
 Back Panel		 Bottom Panel		 Short Wicker Top	
E	1PC	F	1PC	G	1PC

HARDWARE LIST

 Short Bolt(M6*10mm)		 Long Bolt(M6*35mm)		 Inner Thread Bolt(M6*40mm)	
H	2PCS	I	16PCS	J	2PCS
 Washer(M6mm)		 Allen Key(M6mm)			
K	16PCS	L	2PCS		

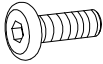
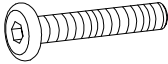
EXTRA HARDWARE LIST

 H X1PC	 I X3PCS	 J X1PC	 K X3PCS
---	--	--	--

Step 1. Attach Side Panels(B&C) to Long Wicker Top(A) using Long Bolts(I), Washers(K) and Allen Key (L).
NOTE: Thread down but do not tighten bolts until unit is fully assembled.

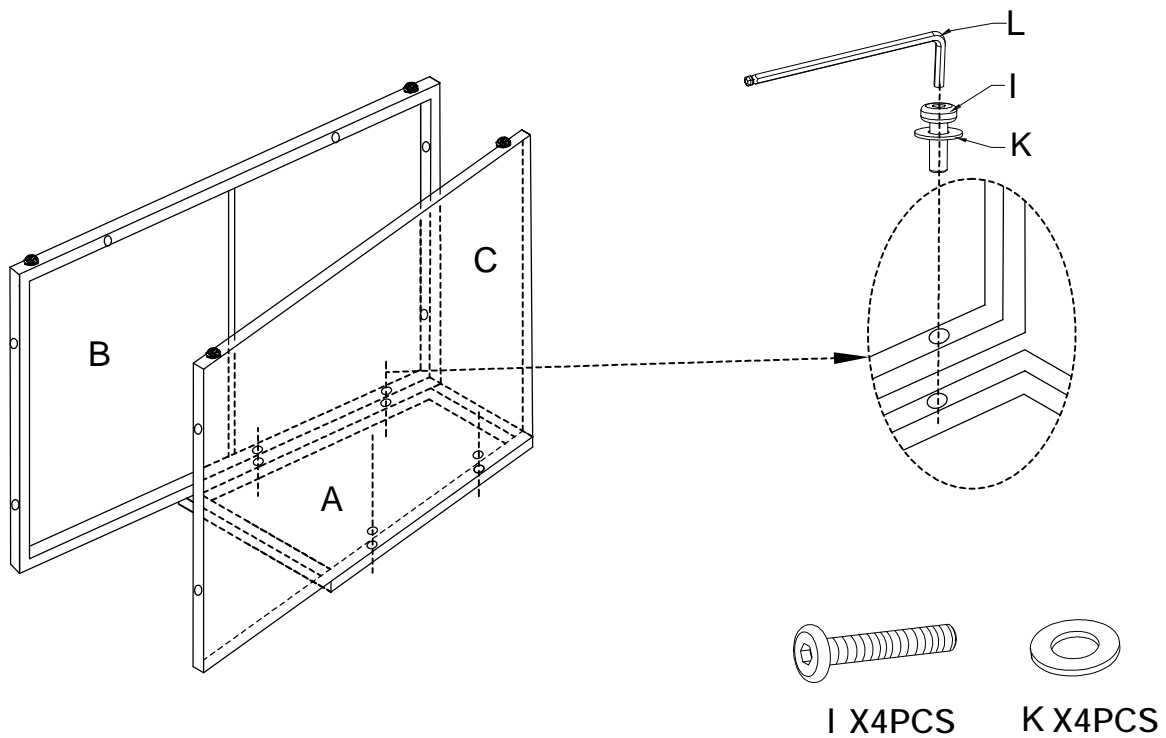

Step 2. Attach Front Panel(D) to assembled parts(A,B&C) using Long Bolts(I), Washers(K) and Allen Key (L).

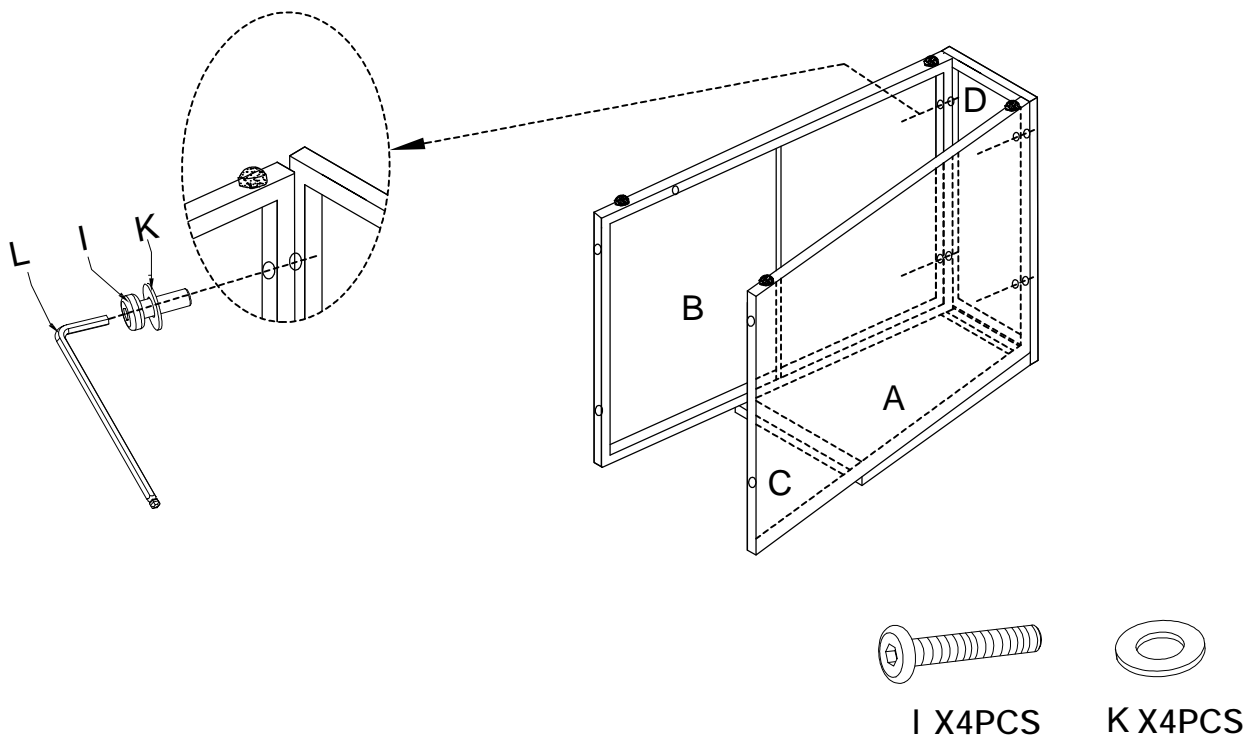

Step 3. Attach Back Panel(E) to assembled parts(A,B,C&D) using Long Bolts(I), Washers(K) and Allen Key (L).

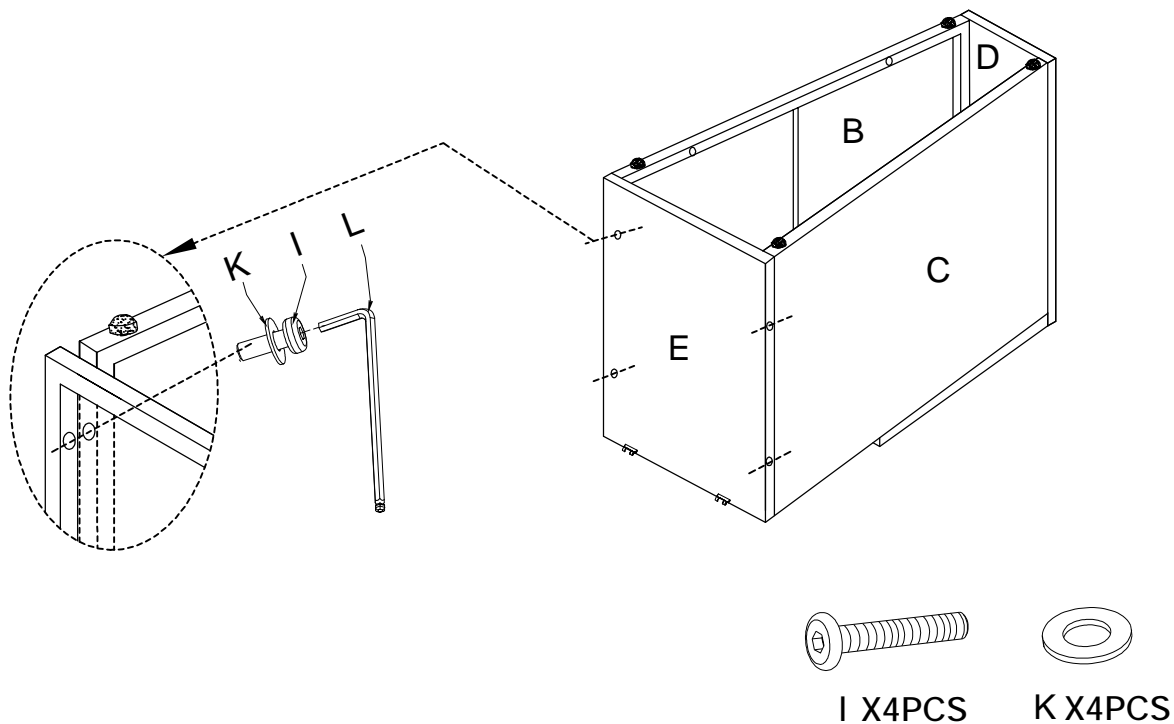

Step 4. Attach Bottom Panel(F) to assembled parts(A,B,C,D&E) using Long Bolts(I), Washers(K) and Allen Key (L).

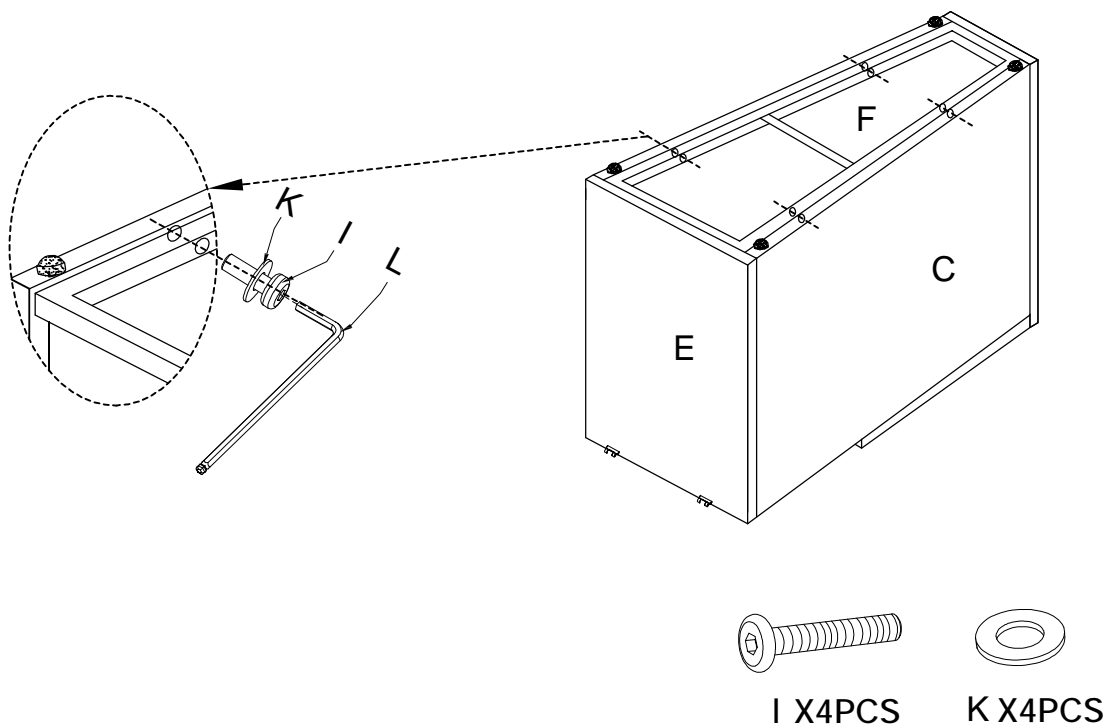

Step 5. Carefully turn the table upright. Attach Short Wicker Top(G) to Back Panel(E) using Inner Thread Bolts(J), Short Bolts(H) and Allen Key(L).

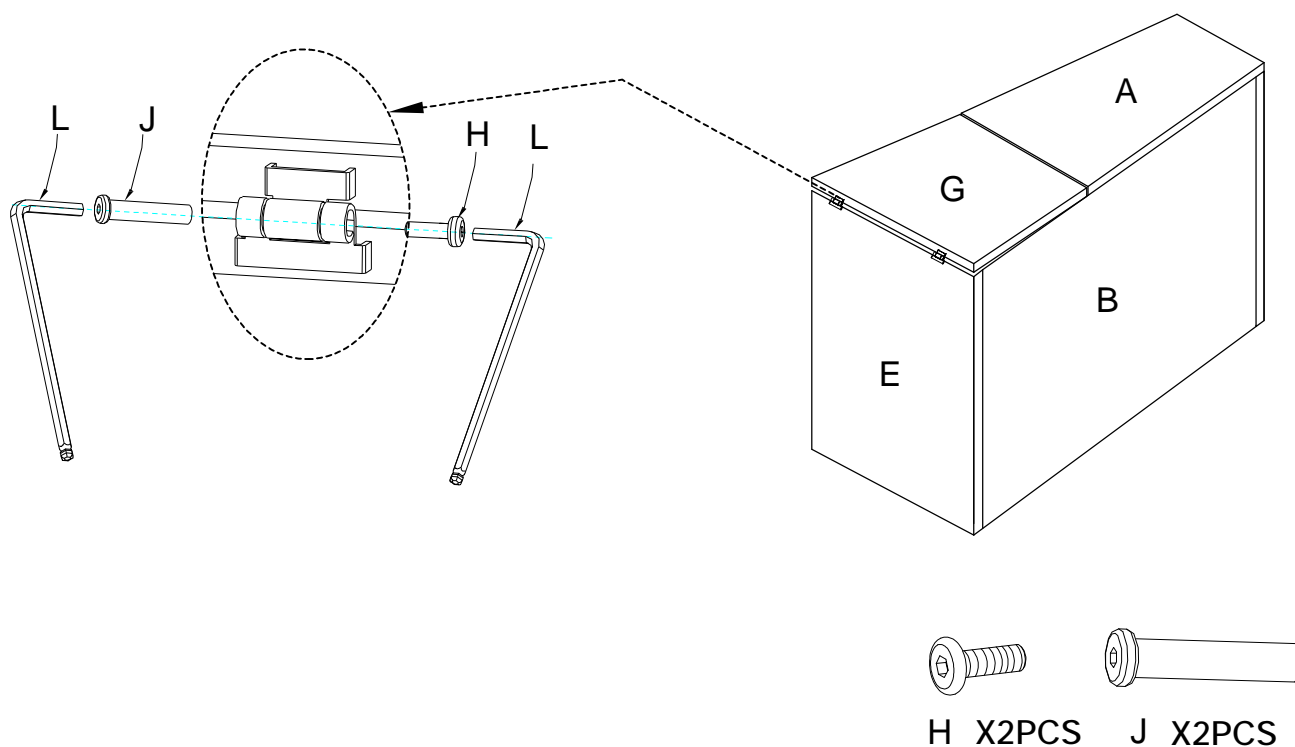

Step 6. Top Panel (G) can be opened and closed.

