

STEP 3

Attach Panel (C) and tighten Leg (3), as shown.

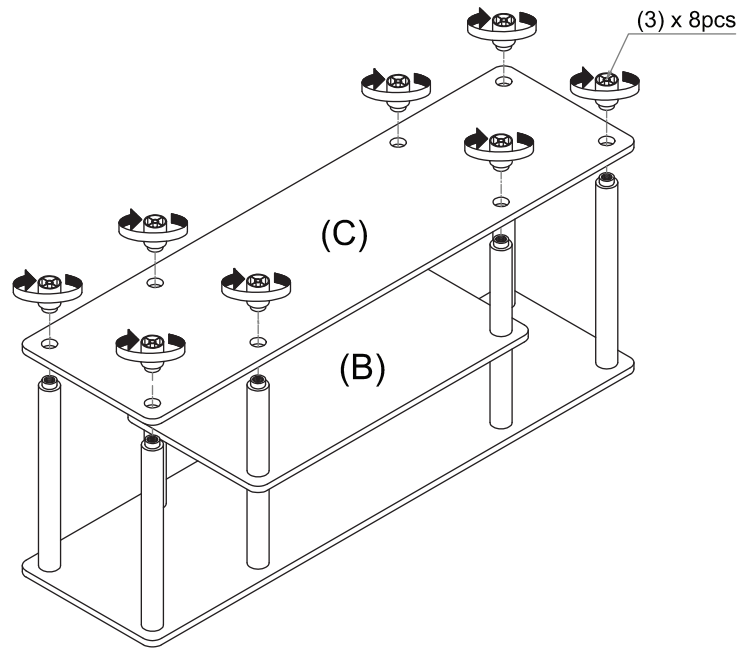

Recommended Maximum Weight

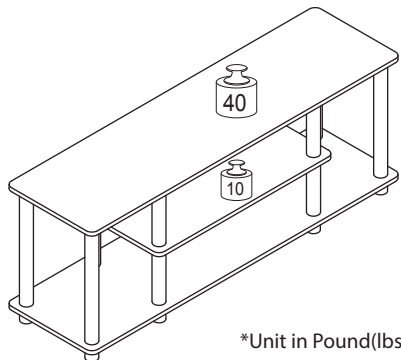

WARNING:

>This unit has been designed to support the maximum loads shown. Exceeding these load limits could cause sagging, instability, product collapse, and/or serious injury.

>DO NOT allow children to climb on unit.

>Put heavier items on lower shelves.

Assembly Instruction

Entertainment TV Stands

00:20

Approx. 20 minutes



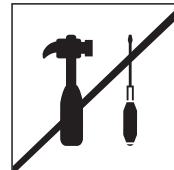

Recomm. 1 Person

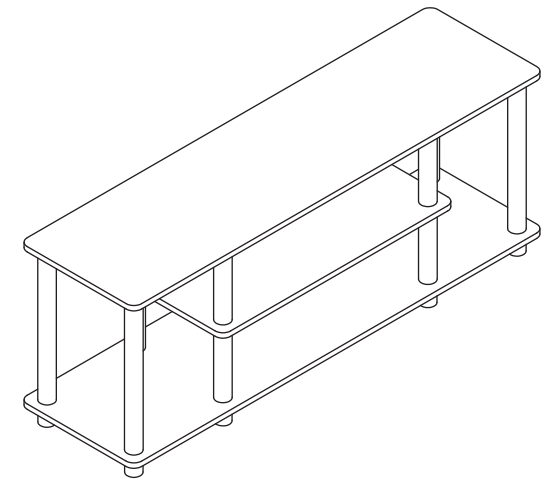

No Tools Required



No	Hardware List	Qty
1	Long Pole 	4pcs
2	Short Pole 	8pcs
3	Round Leg 	8pcs

No	Parts List	Qty
A	Top Panel	1pc
B	Shelf Panel	1pc
C	Bottom Panel	1pc

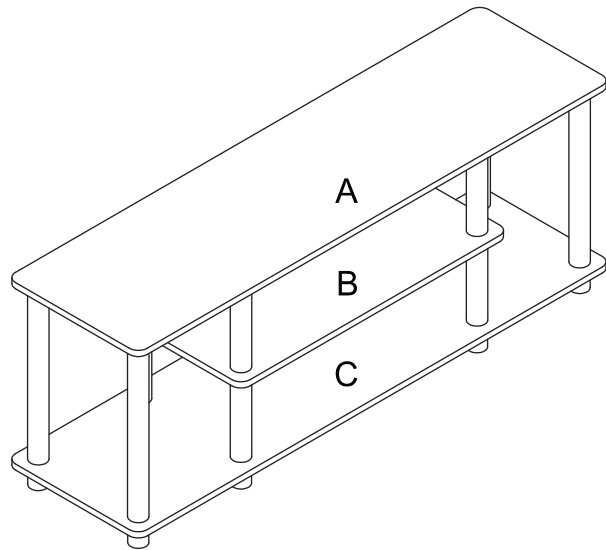

USEFUL HINTS BEFORE YOU START:

1. Read each step carefully before starting.
2. It is important that each step is performed in correct order to avoid difficulties.
3. Identify, sort and count the parts before assembly.
4. Assemble your furniture on packaging cardboard to prevent scratch or damage.
5. Clean the product with mild cleanser using soft damped cloth. Do not use harsh or abrasive cleanser.
6. Using incompatible hardware might cause damage to product.

STEP 1

Attach Pole (1) & (2) to Panel (A) and tighten it, as shown.

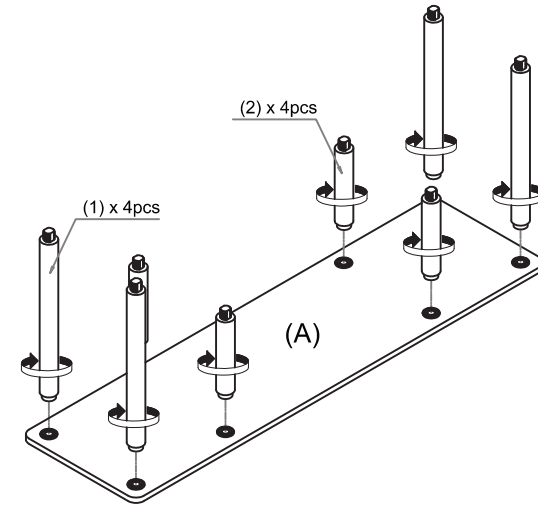

STEP 2

Attach Shelf Panel (B) and tighten Pole (2), as shown.

