

# **ASSEMBLY INSTRUCTIONS**

### ASSEMBLY TIPS:





1. Remove hardware from box and sort by size
2. Please check to see that all hardware and parts are present prior to start of assembly.
3. Please follow attached instruction in the same sequence as numbered to assure fast & easy assembly.





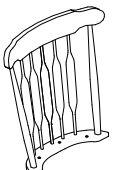

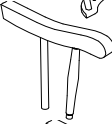
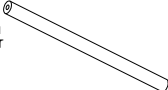

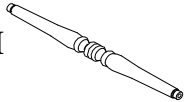
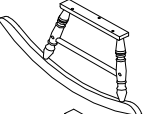
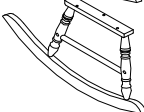
#### Warning!

1. Don't attempt to repair or modify parts that are broken or defective. Please contact the store immediately.
2. This product is for home use only and not intended for commercial establishment.

## PARTS IDENTIFICATION

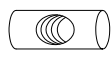
<b>A</b>		CHAIR BACK	1PC	<b>F</b>		WOODEN SEAT	1PC
<b>B</b>		LEFT ARM REST	1PC	<b>G</b>		BACK STRETCHER	1PC
<b>C</b>		RIGHT ARM REST	1PC	<b>H</b>		FRONT STRETCHER	1PC
<b>D</b>		LEFT LEG FRAME	1PC				
<b>E</b>		RIGHT LEG FRAME	1PC				

## HARDWARE IDENTIFICATION

<b>1</b>		LONG BOLT	8PCS	<b>6</b>		ALLEN WRENCH	1PC
<b>2</b>		SHORT BOLT	9PCS	<b>7</b>		BARREL NUT	6PCS
<b>3</b>		LOCK WASHER	17PCS	<b>8</b>		WOOD PLUG	9PCS
<b>4</b>		BIG FLAT WASHER	2PCS				
<b>5</b>		SMALL FLAT WASHER	15PCS				

### STEP 1

Align and fasten front and back stretchers to left and right leg frame using barrel nut, long bolt, lock washer and small flat washer and tighten with Allen wrench. Insert wood plug into the open holes of leg frame.

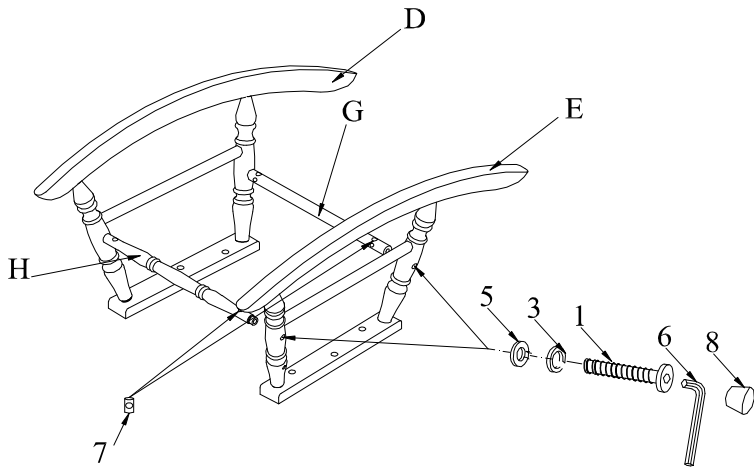

### STEP 2

Place wooden seat upside down on soft surface. Align and fasten left and right leg frame to wooden seat using short bolt, lock washer and small flat washer and tighten with Allen wrench.

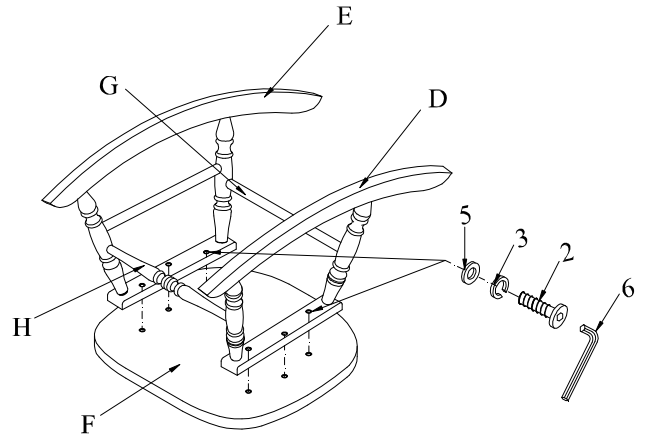

### STEP 3

Align and fasten chair back to wooden seat using short bolt, lock washer and small flat washer and tighten with Allen wrench. Insert wood plug into the open holes of chair back brace.

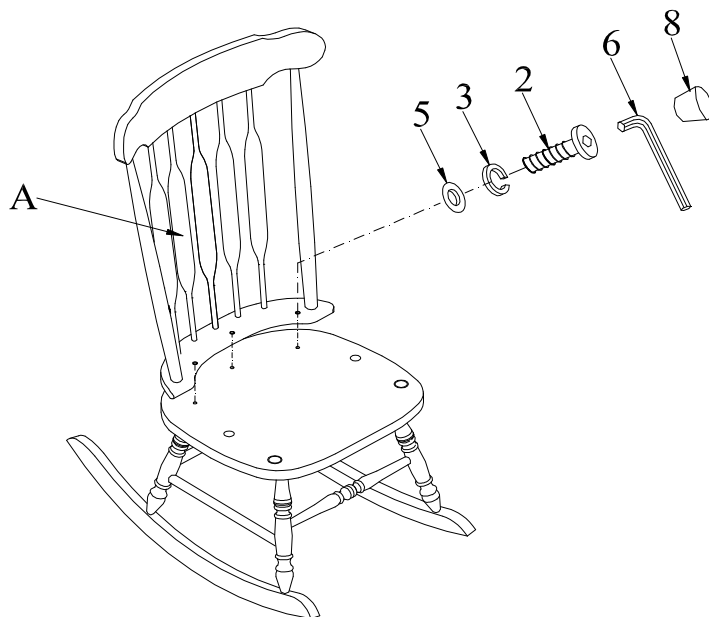

**STEP 4**

4.1) Align and fasten left and right arm rest to wooden seat using long bolt, lock washer and big flat washer. DO NOT FULLY TIGHTEN AT THIS STEP.

4.2) Align and fasten left and right arm rest to chair back using long bolt, lock washer and small flat washer. THEN FULLY TIGHTEN ALL THE BOLTS AT STEP 4.1 & 4.2 WITH ALLEN WRENCH. Insert wood plug into the open holes of chair back.

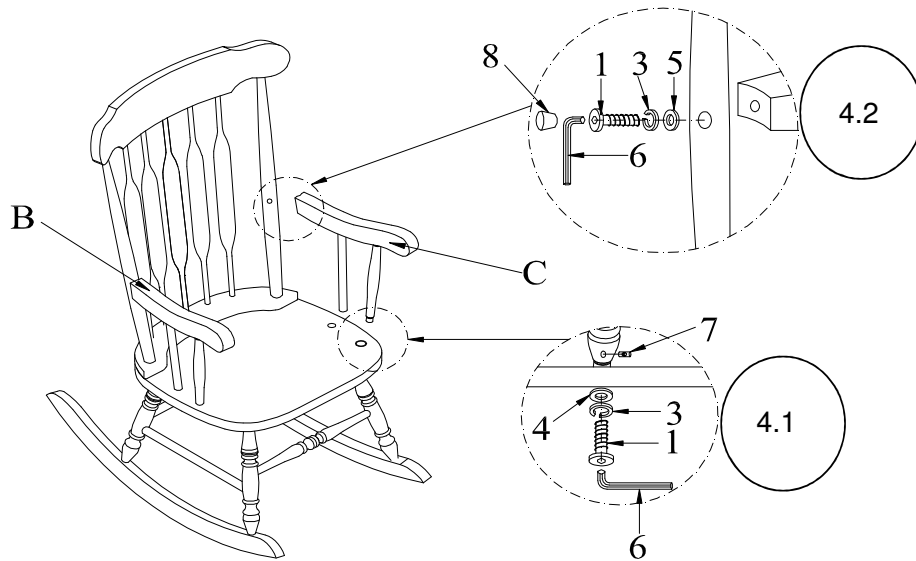

**STEP 5**

Complete.

