

L-shaped computer desk
USER'S MANUAL

SKU:HO005601

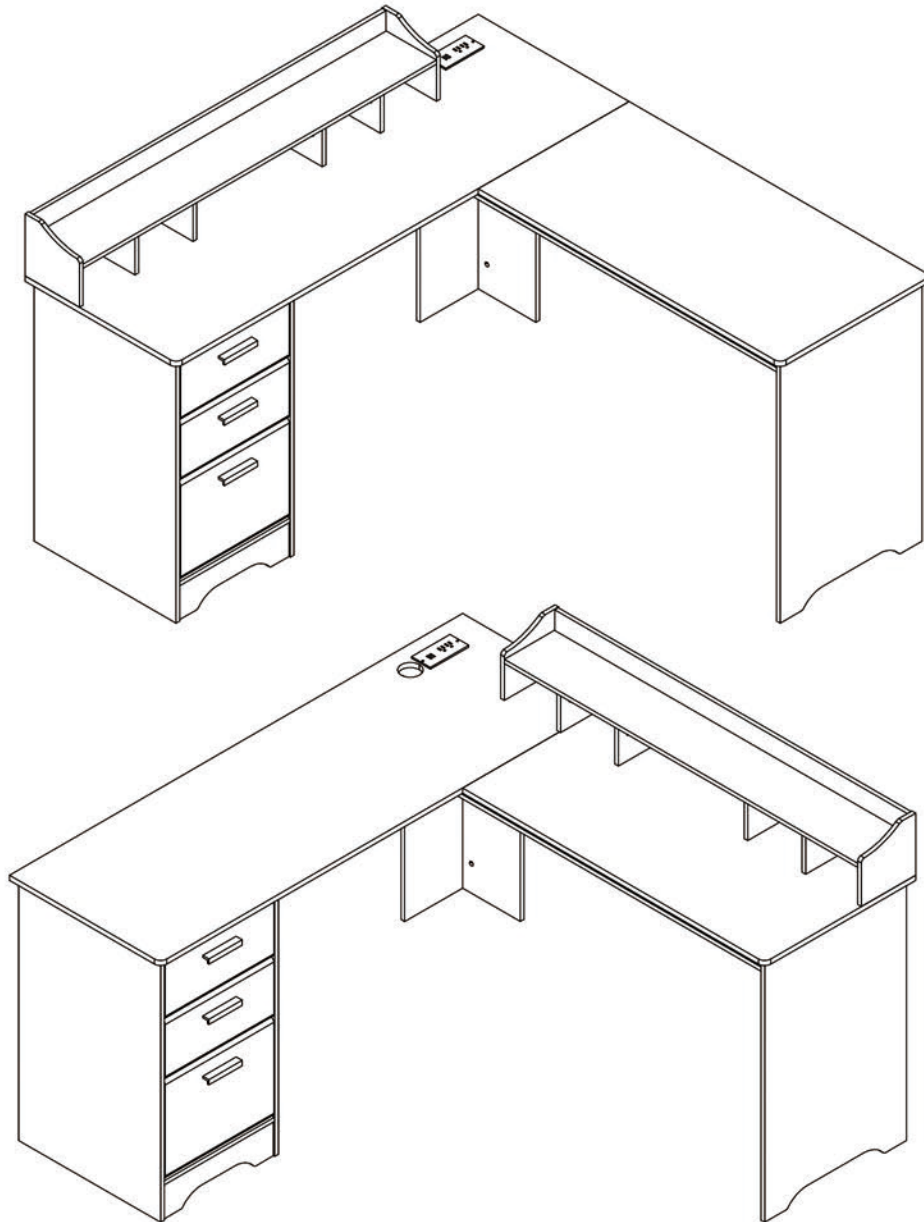

ASSEMBLY INSTRUCTION

ADULT ASSEMBLY REQUIRED

**THE PRODUCT MAY RECOMMENDED
ASSEMBLING BY MORE THAN ONE
PERSON.**

**PLEASE ASK FOR ASSISTANCE AT YOUR
CONVENIENCE BEFORE ASSEMBLING.**

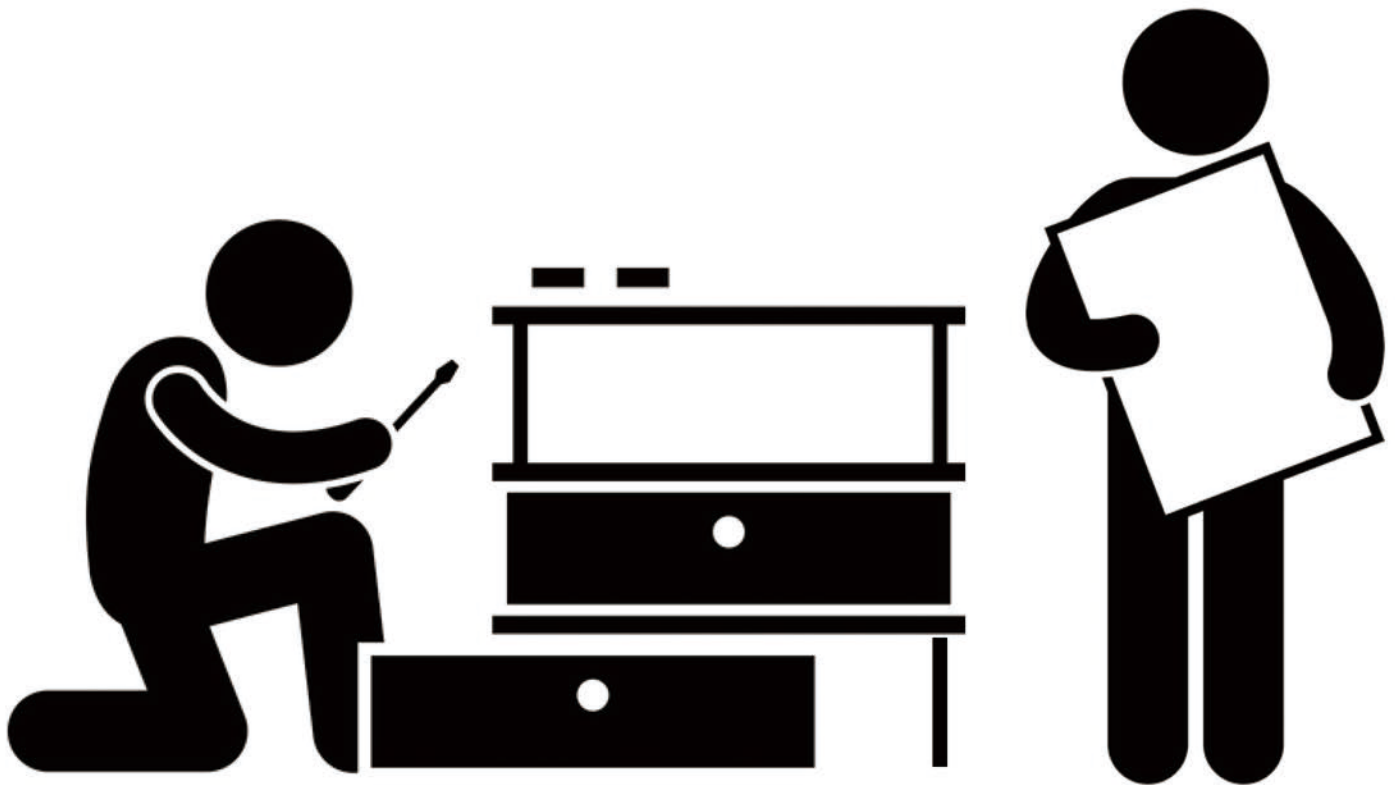

Before You Start

1. Read through each step carefully and follow the proper order
2. Separate and count all your parts and hardware
3. Give yourself enough room for the assembly process
4. Caution: If using a power drill or power screwdriver for screwing, please be aware to slow down and stop when screw is tight. Failure to do so may result in stripping the screw.

Cam Lock Fastening System



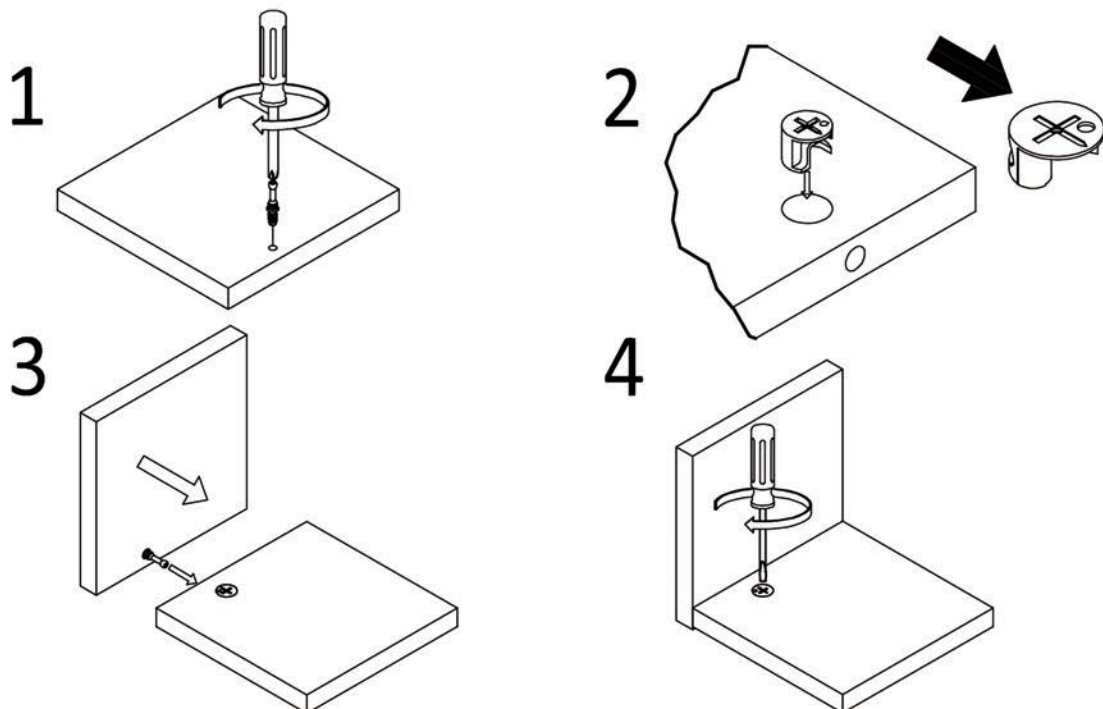



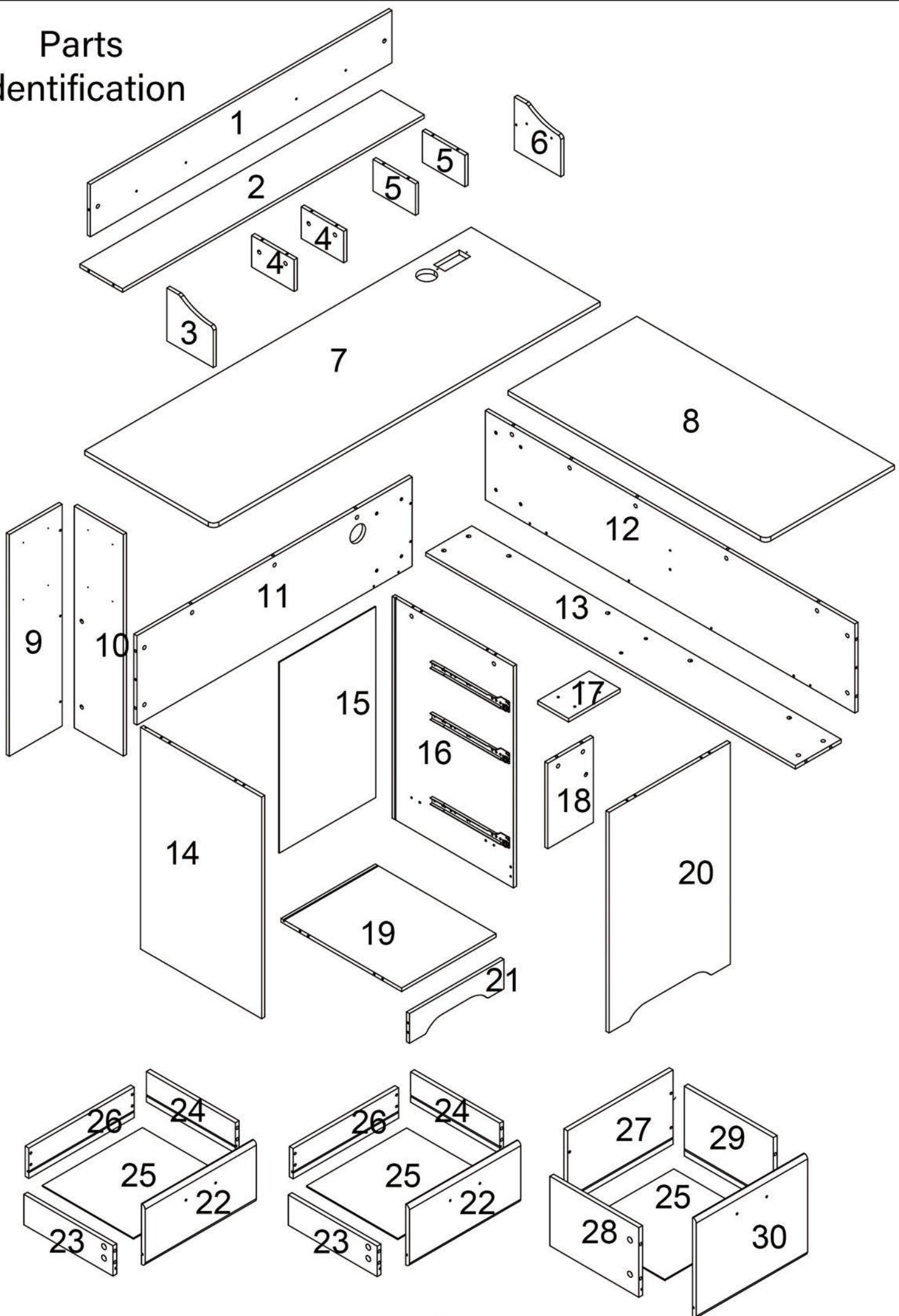

This Cam Lock Fastening System will be used throughout the assembly process.

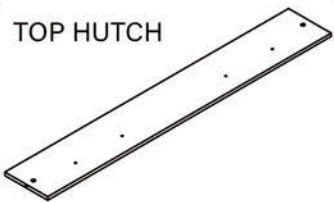
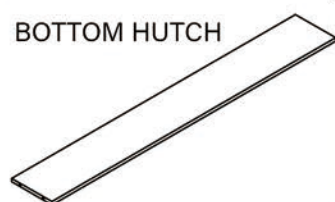
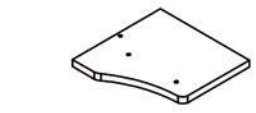

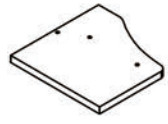
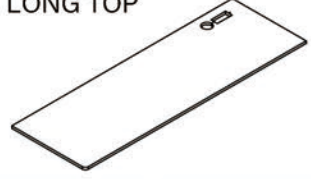
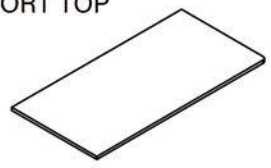
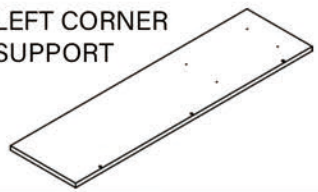
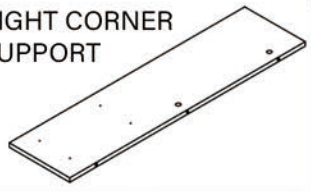
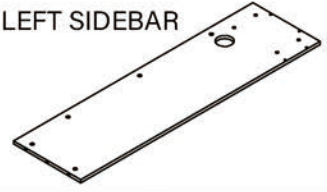
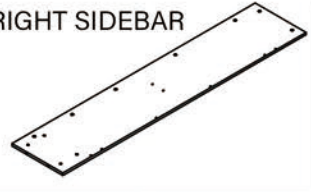
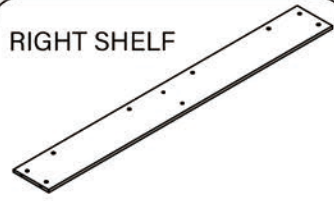
Parts Identification

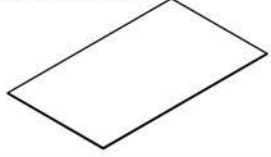

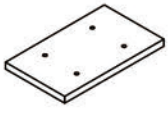
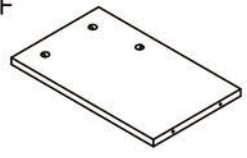
Parts List

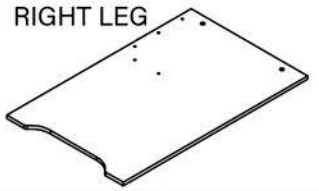
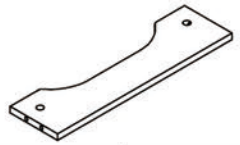
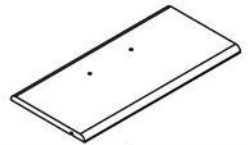
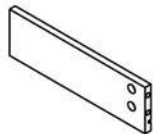
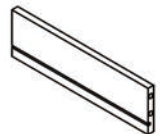
TOP HUTCH 	BOTTOM HUTCH 	LEFT HUTCH 	LEFT HUTCH SUPPORTx2 
1 1PC	2 1PC	3 1PC	4 2PC
RIGHT HUTCH SUPPORT x2 	RIGHT HUTCH 	LONG TOP 	SHORT TOP 
5 2PC	6 1PC	7 1PC	8 1PC
LEFT CORNER SUPPORT 	RIGHT CORNER SUPPORT 	LEFT SIDEBAR 	RIGHT SIDEBAR 
9 1PC	10 1PC	11 1PC	12 1PC
RIGHT SHELF 	LEFT CABINET 	BEHIND CABINET 	RIGHT CABINET 
13 1PC	14 1PC	15 1PC	16 1PC
CONNECTION PALTE 	SHELF 	BOTTOM CABINET 	RIGHT LEG 
17 1PC	18 1PC	19 1PC	20 1PC
CABINET FRONT BOTTOM 	FRONT SMALL DRAWERx2 	LEFT SMALL DRAWERx2 	RIGHT SMALL DRAWERx2 
21 1PC	22 2PC	23 2PC	24 2PC

Parts List

BOTTOM DRAWERx3

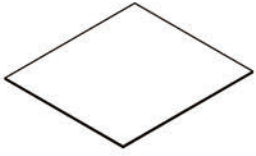

25

3PC

BEHIND SMALL DRAWERx2

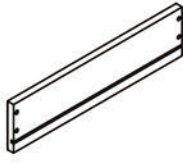

26

2PC

BEHIND BIG DRAWER

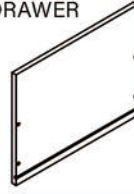

27

1PC

LEFT BIG DRAWER

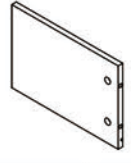

28

1PC

RIGHT BIG DRAWER

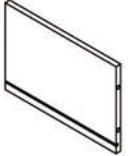

29

1PC

FRONT BIG DRAWER

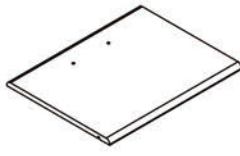

30

1PC

Hardware Identification

CAM BOLTx65



A 65PC

CAM LOCKx65



$\phi 12$

B 65PC

WOOD DAWELx22



$\phi 6 \times 30 \text{mm}$

C 22PC

SCREWx14



$\phi 4 \times 40 \text{mm}$

D 14PC

HANDLEx3

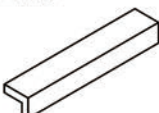

E 3PC

BOLTx6



M4*15mm

F 6PC

SCREWx24



$\phi 3 \times 12 \text{mm}$

G 24PC

SCREWx12



$\phi 4 \times 22 \text{mm}$

H 12PC

LEFT SLIDEx3



I 3PC

RIGHT SLIDEx3

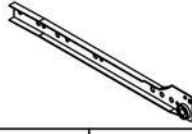

J 3PC

DRAWER LEFT SLIDEx3



K 3PC

DRAWER RIGHT SLIDEx3

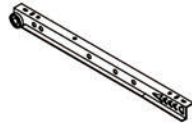

L 3PC

SOCKETx1



M 1PC

SOCKET SCREWx2



$\phi 3 \times 12 \text{mm}$



N 2PC

COIL COVERx1





O 1PC

STEP 1

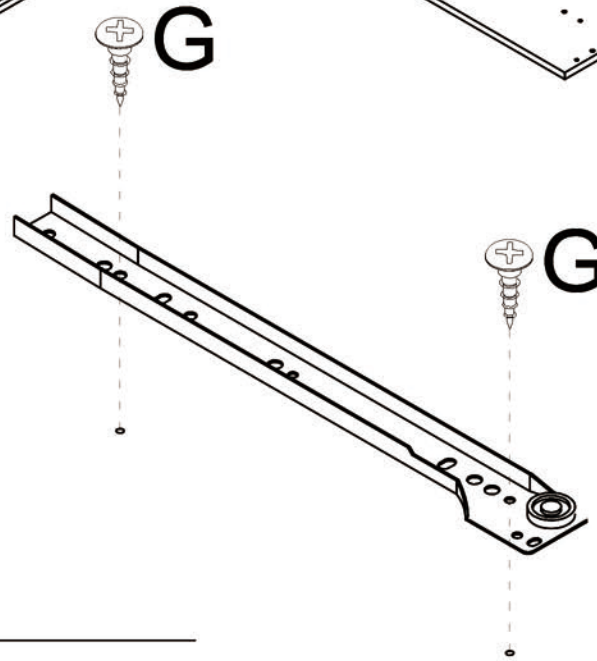
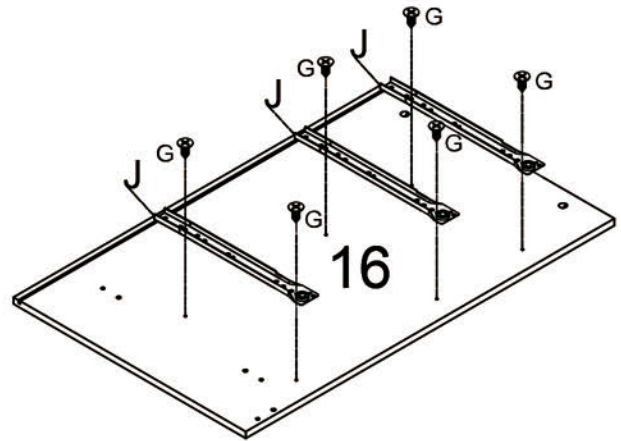
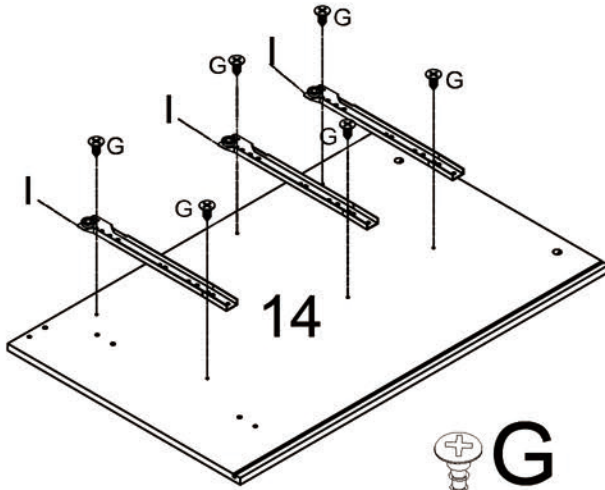
		 ø3*12mm
I 3PC	J 3PC	G 12PC



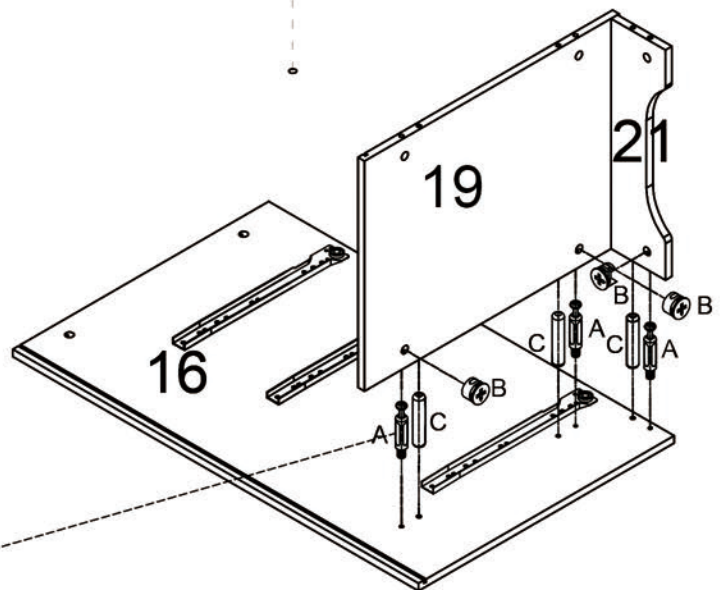
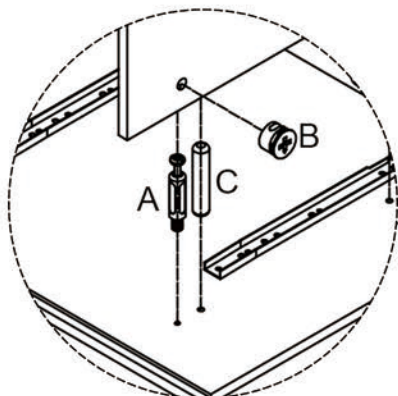

STEP 2

	 ø12	 Ø6*30mm
A 3PC	B 3PC	C 3PC



STEP 3

					
A	3PC	B	3PC	C	3PC
		Ø12		Ø6*30mm	

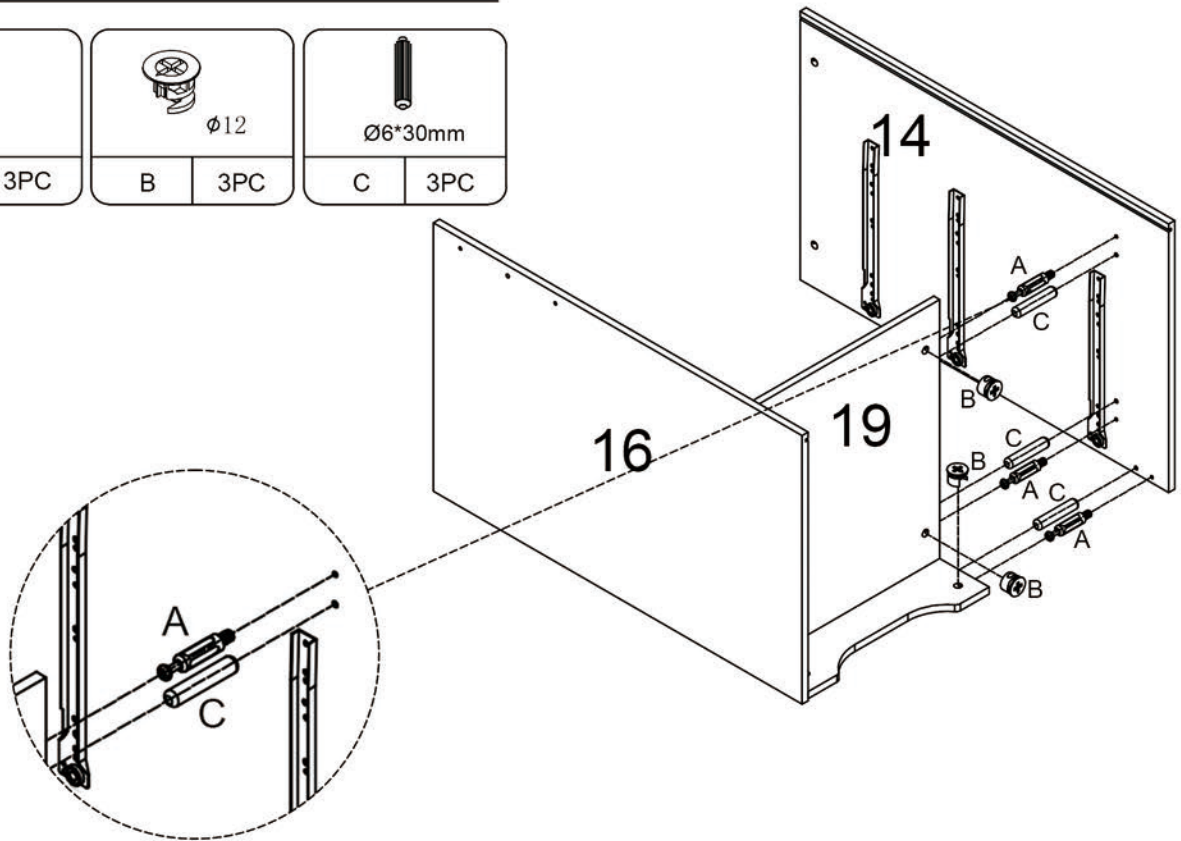

STEP 4

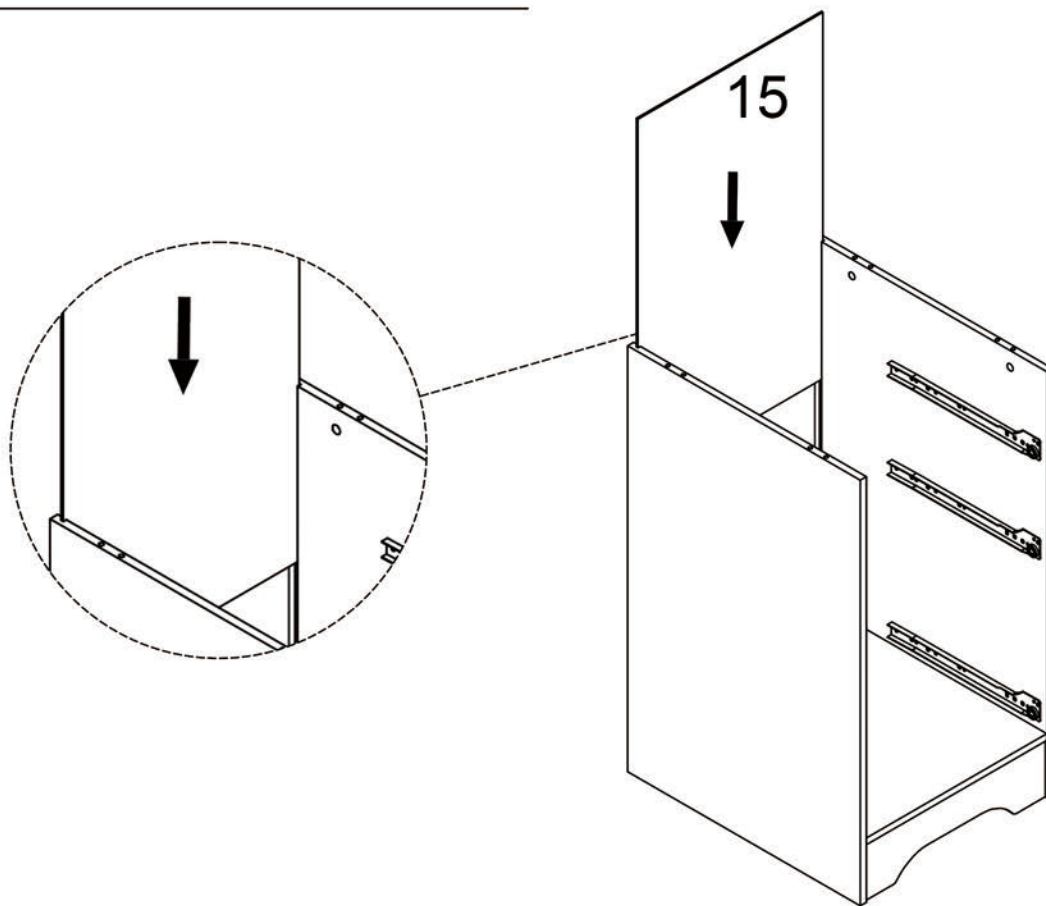

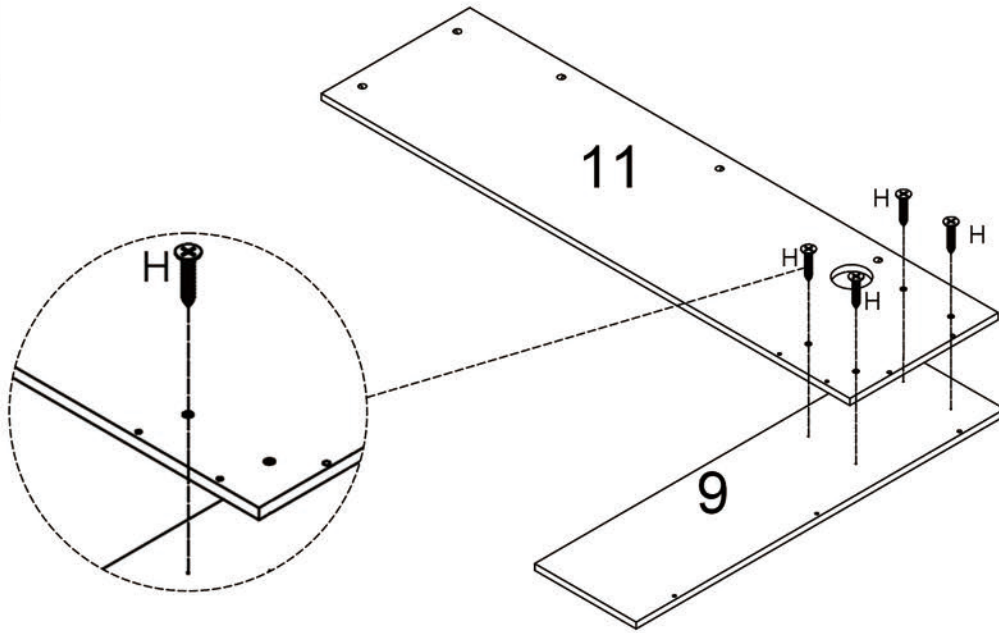

STEP 5

	
Ø4*22mm	
H	4PC



STEP 6

		
A	Ø12	Ø6*30mm
2PC	2PC	1PC

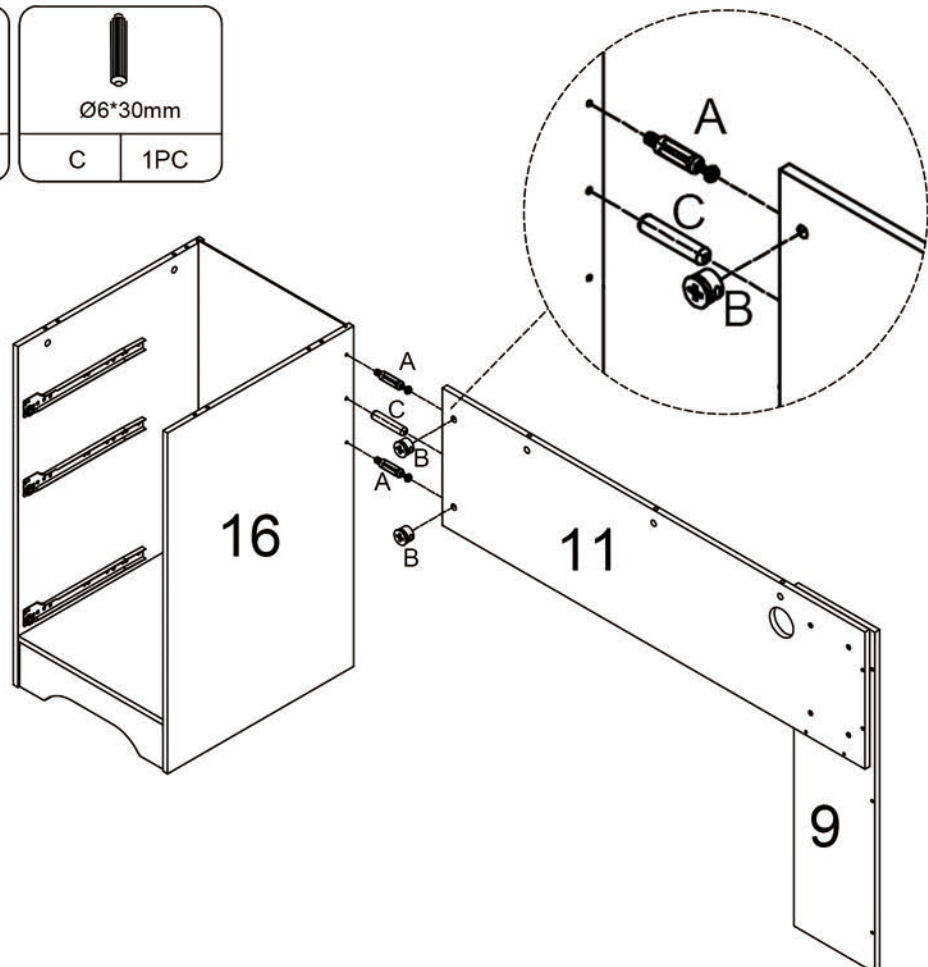

Important

2 people required
2 personnes requises
2 personas requeridas

STEP 7

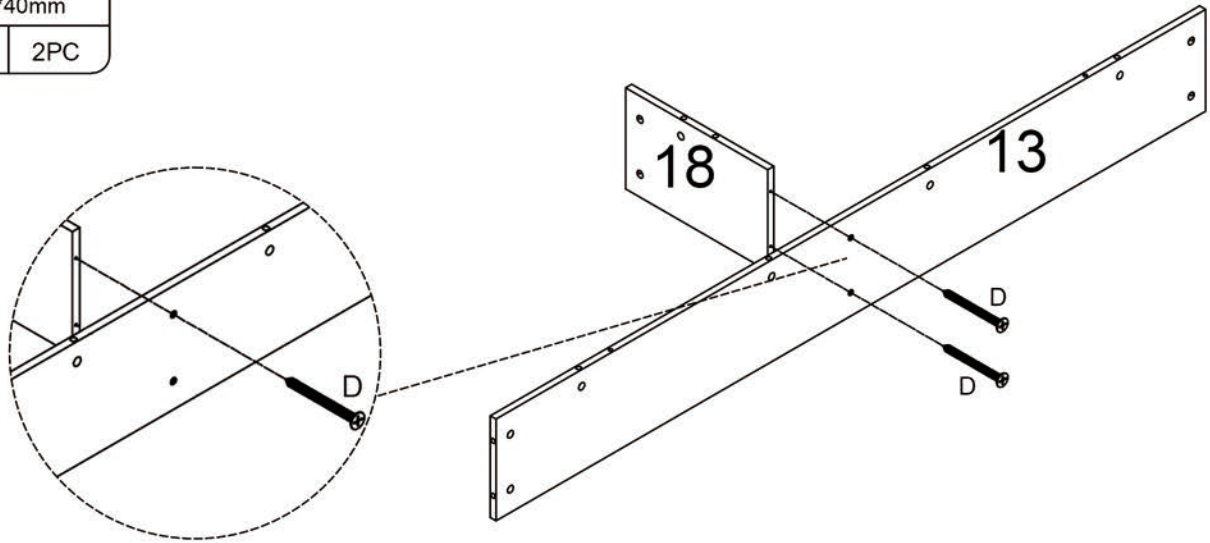
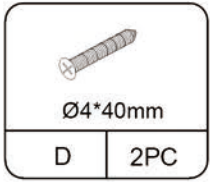

STEP 8

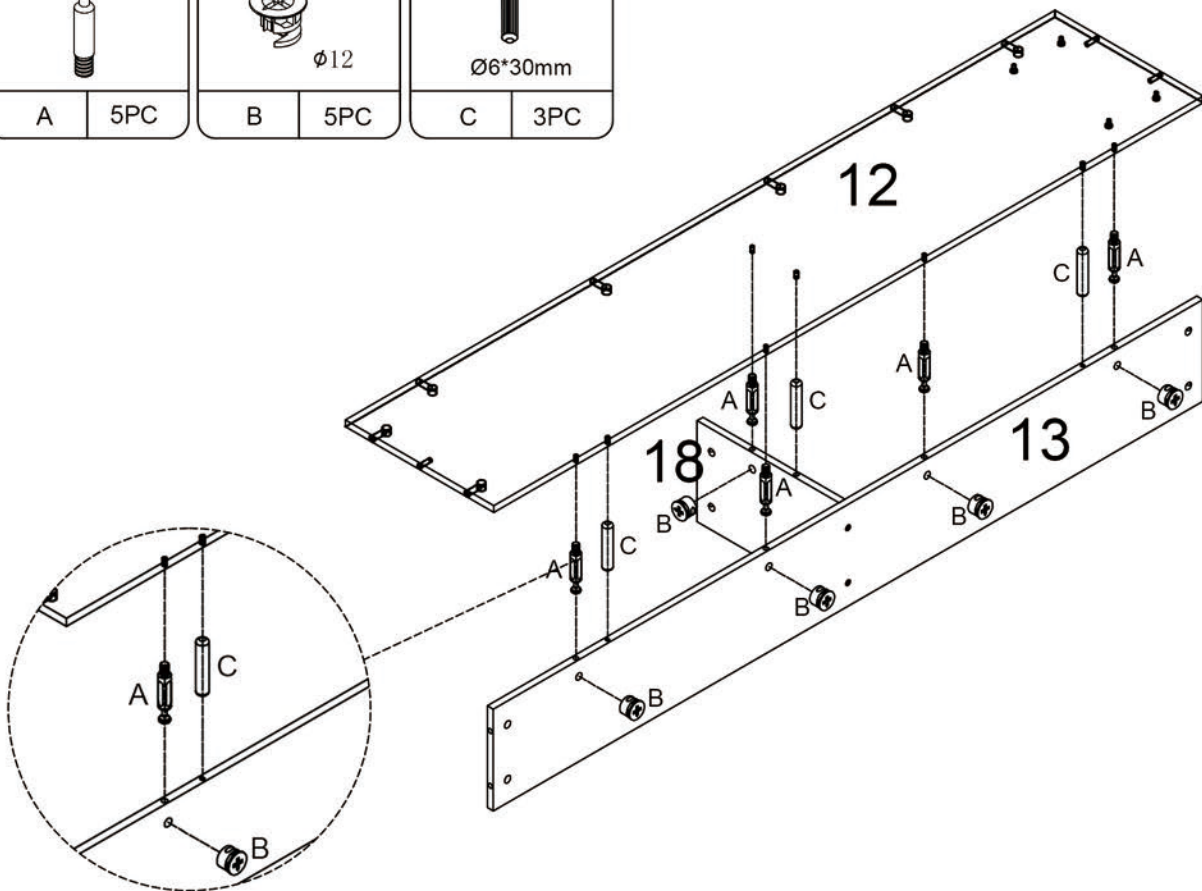
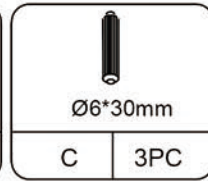
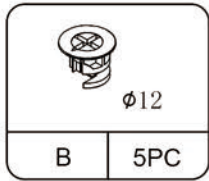
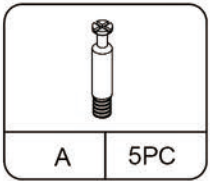

STEP 9

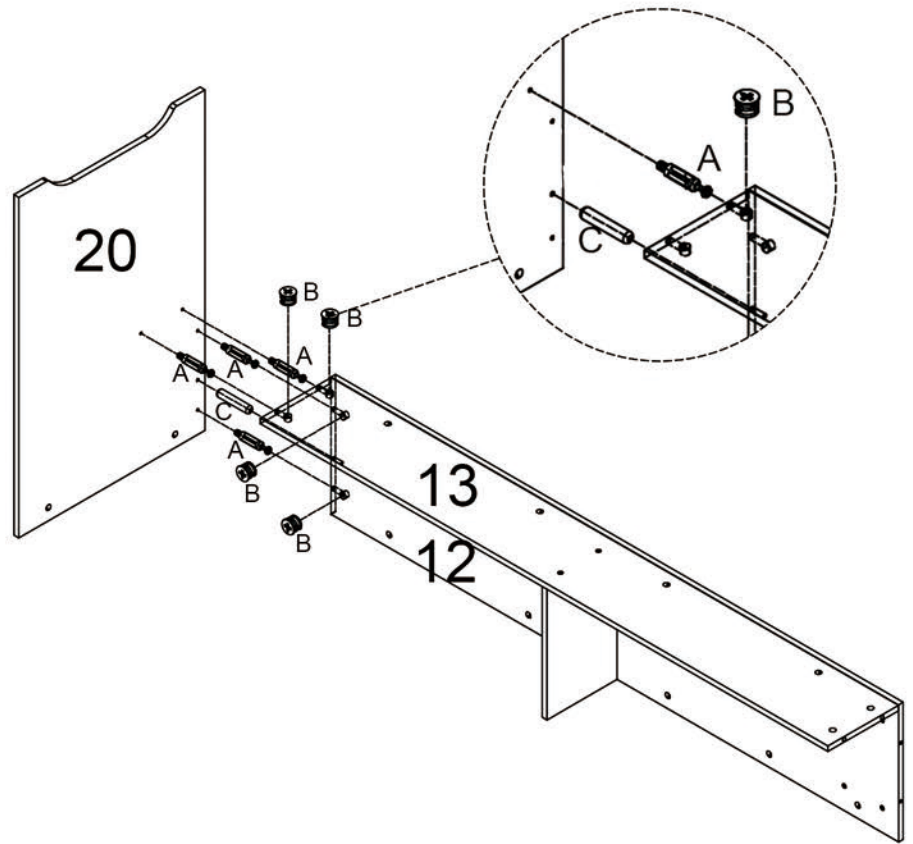
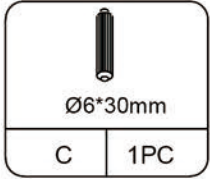
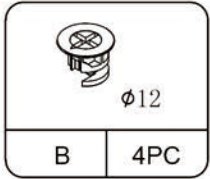
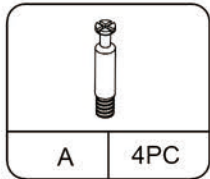

STEP 10

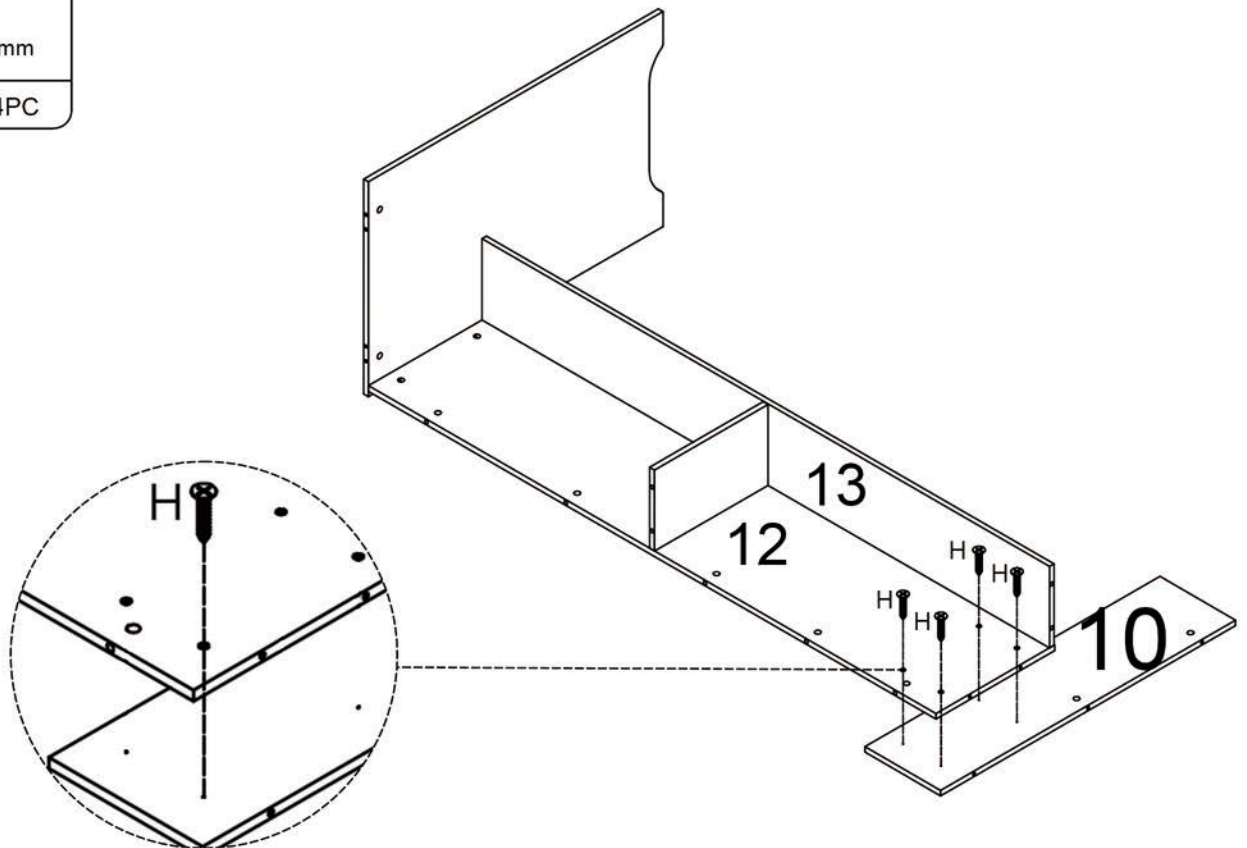
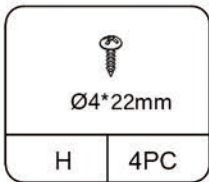

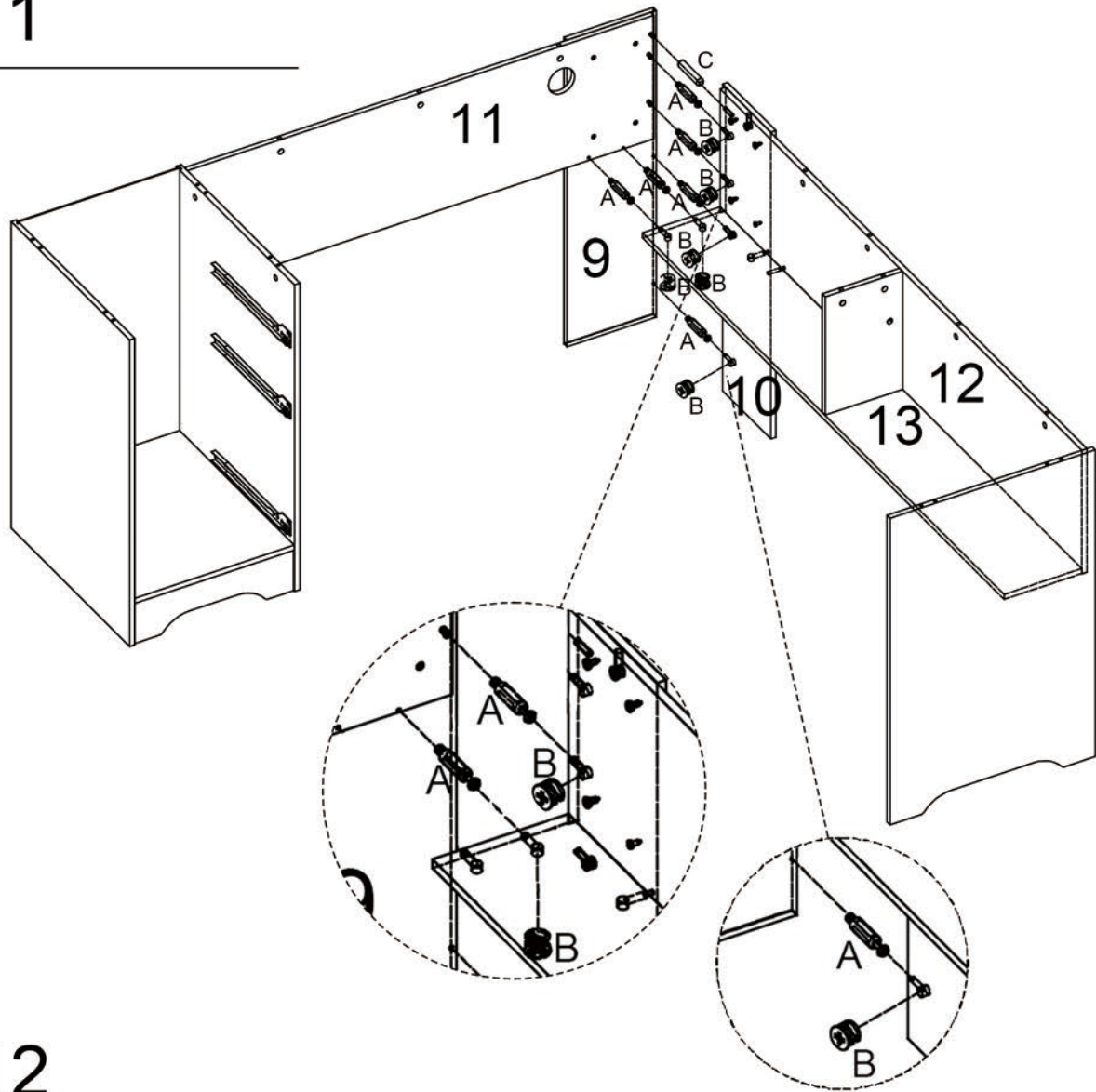
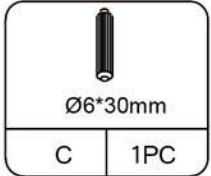
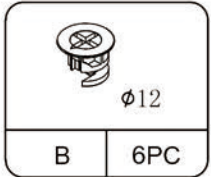
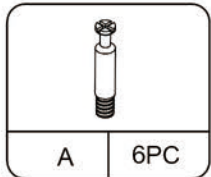

STEP 11

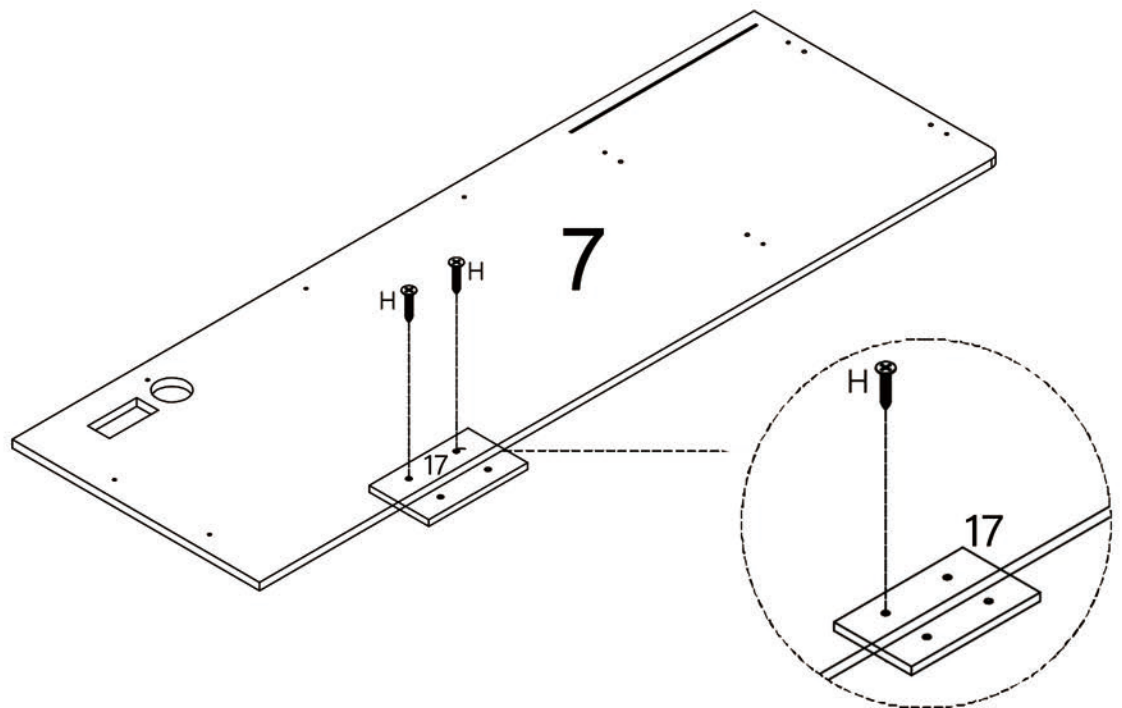
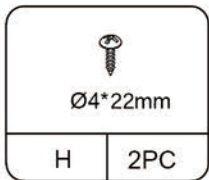

STEP 12



STEP 13

		
A	Ø12	Ø6*30mm
9PC	9PC	4PC

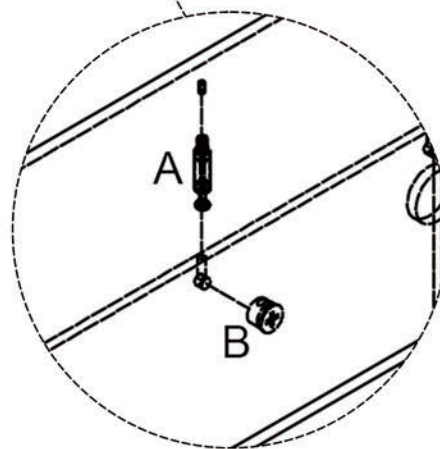
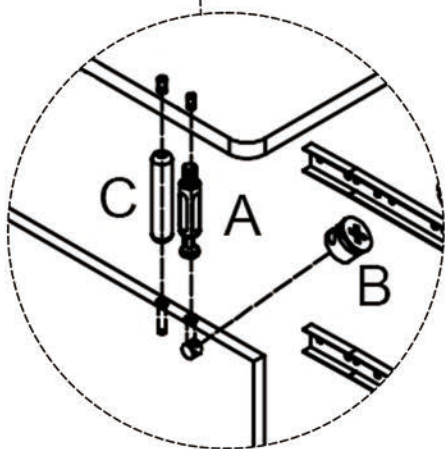
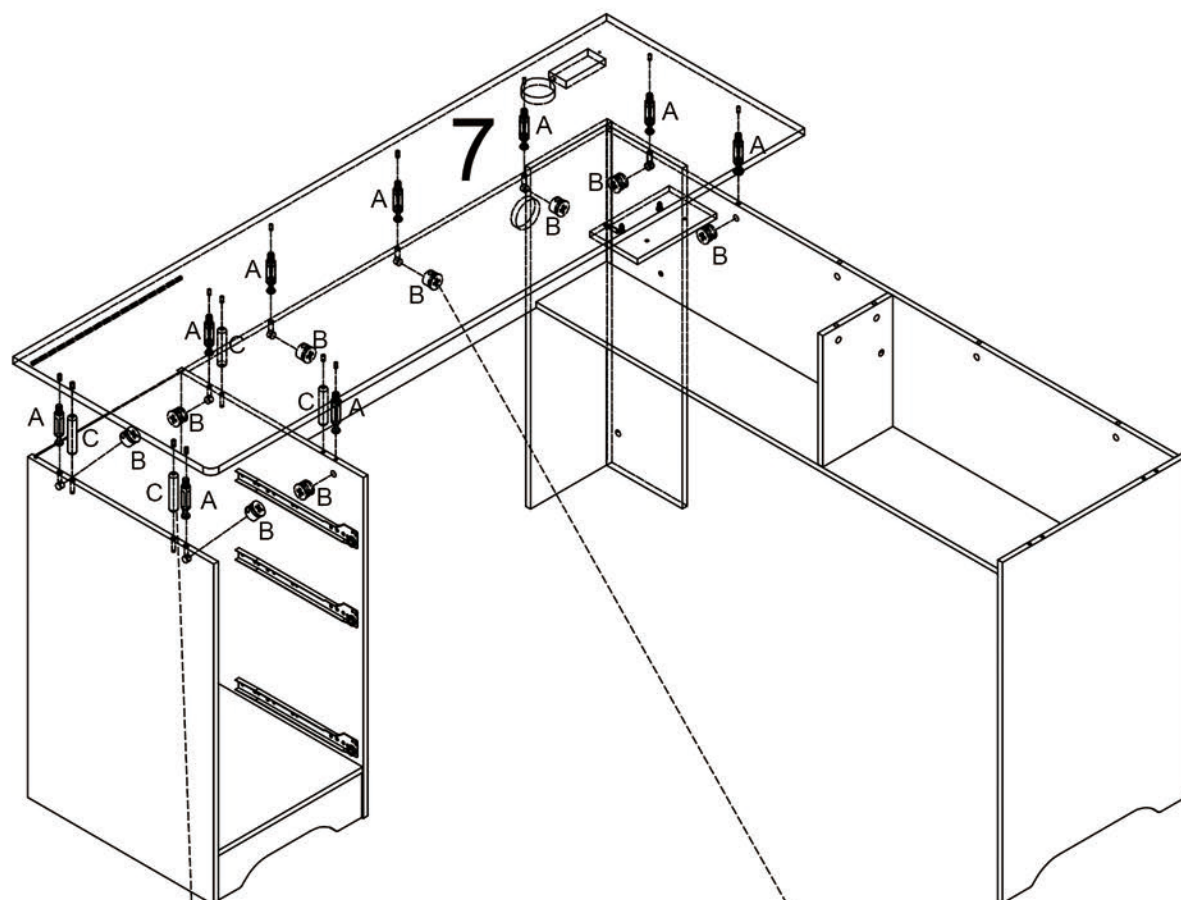

STEP 15

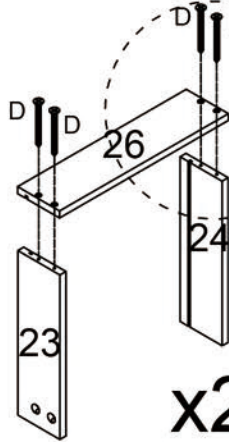
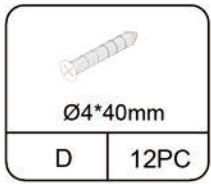

x2PC

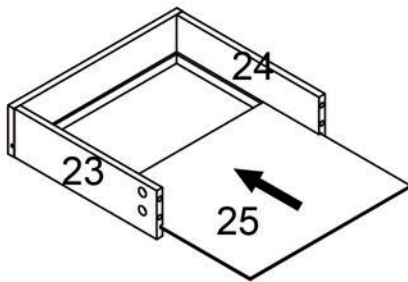
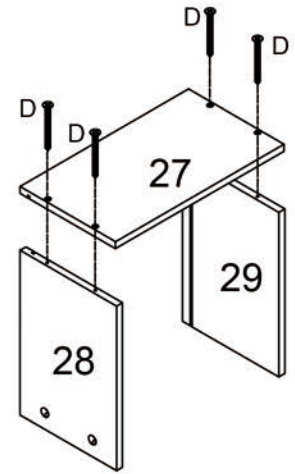

x2PC

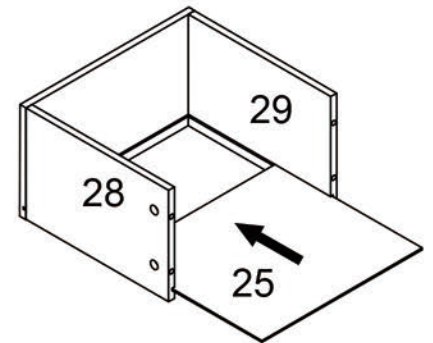

STEP 16

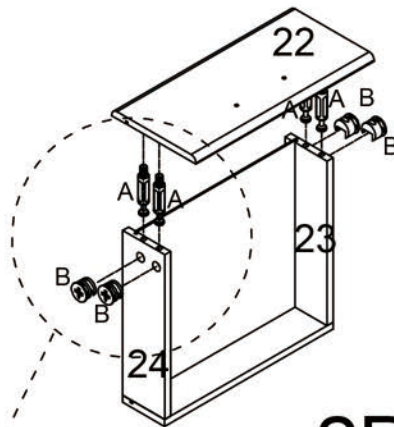
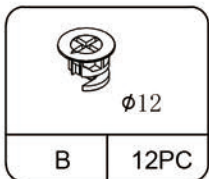
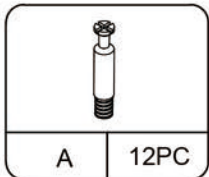

x2PC

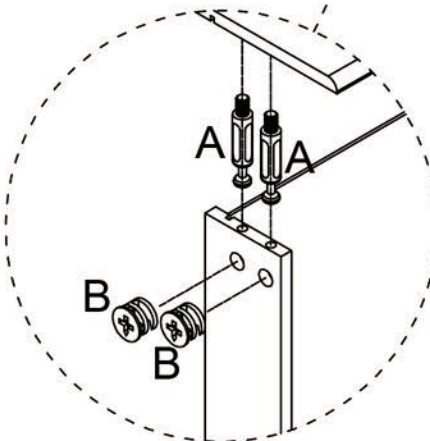
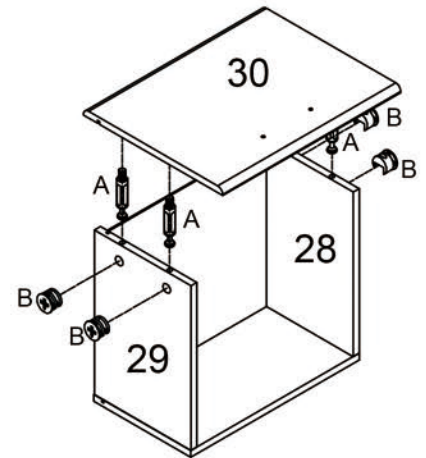

STEP 17

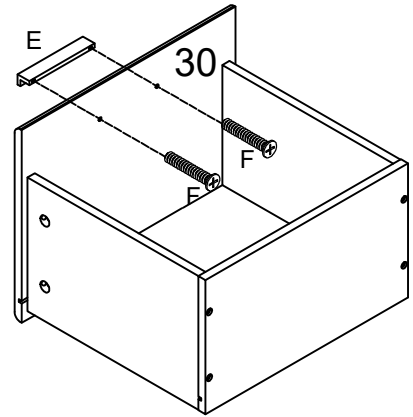
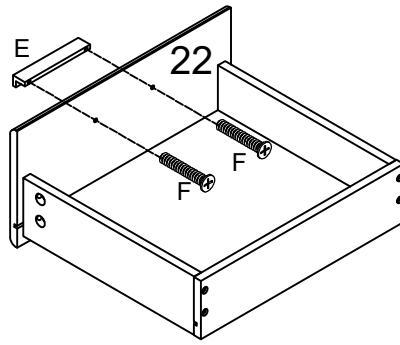
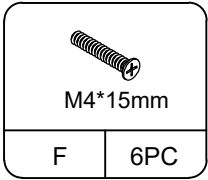
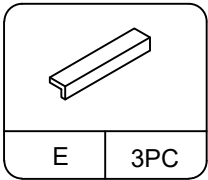

x2PC

STEP 18

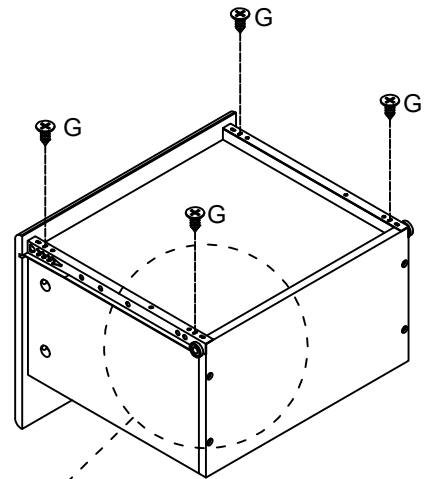
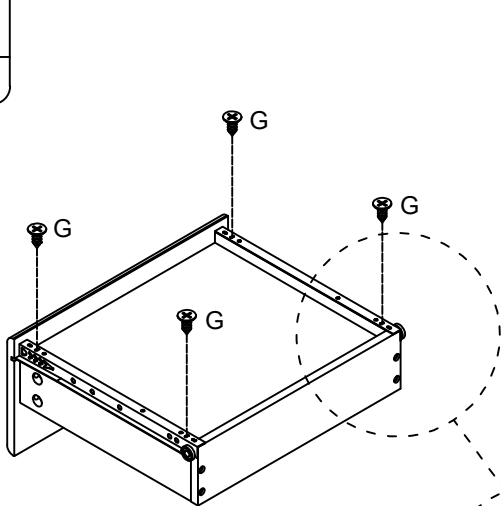
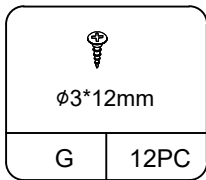

x2PC

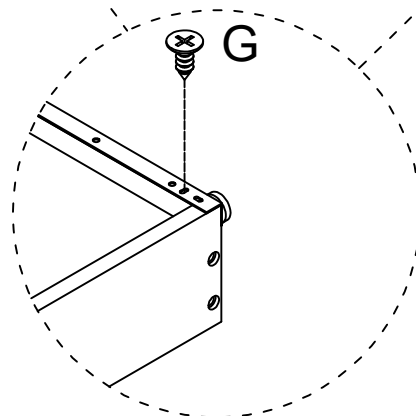

STEP 19

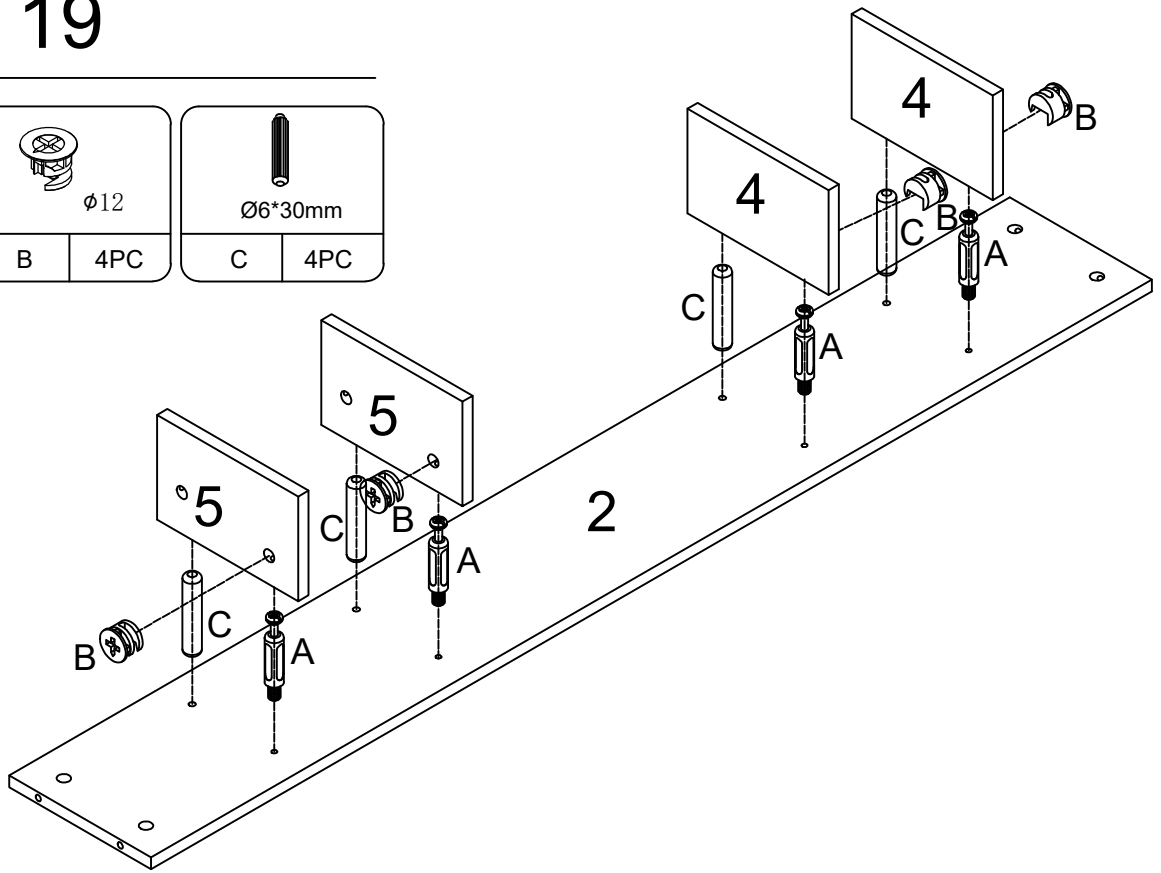
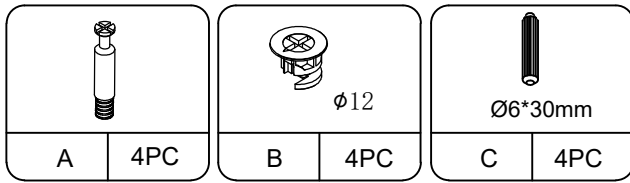

STEP 20

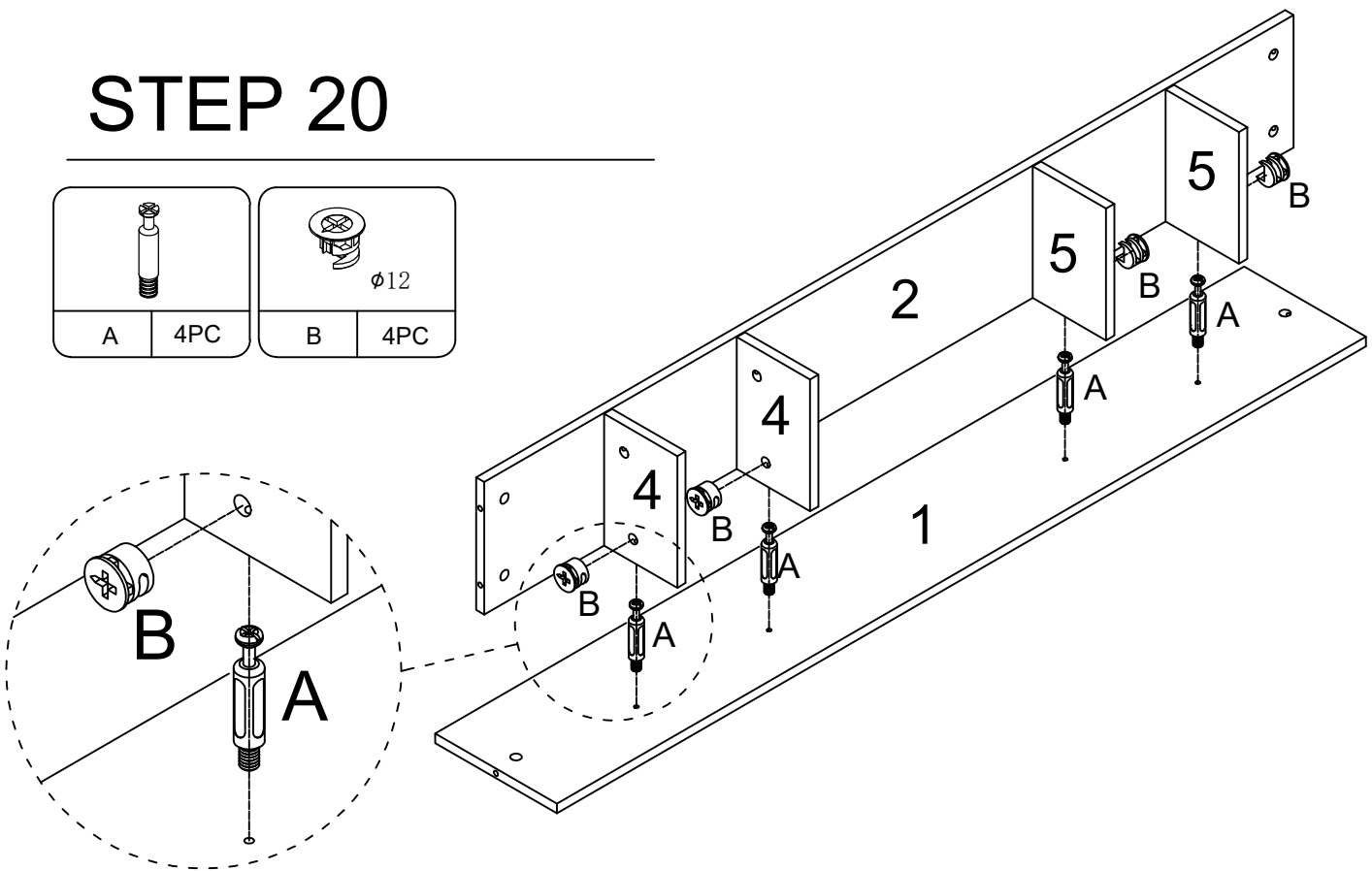
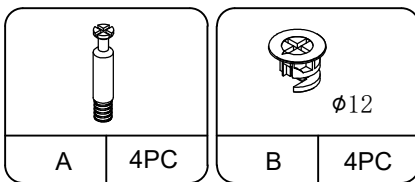

STEP 21

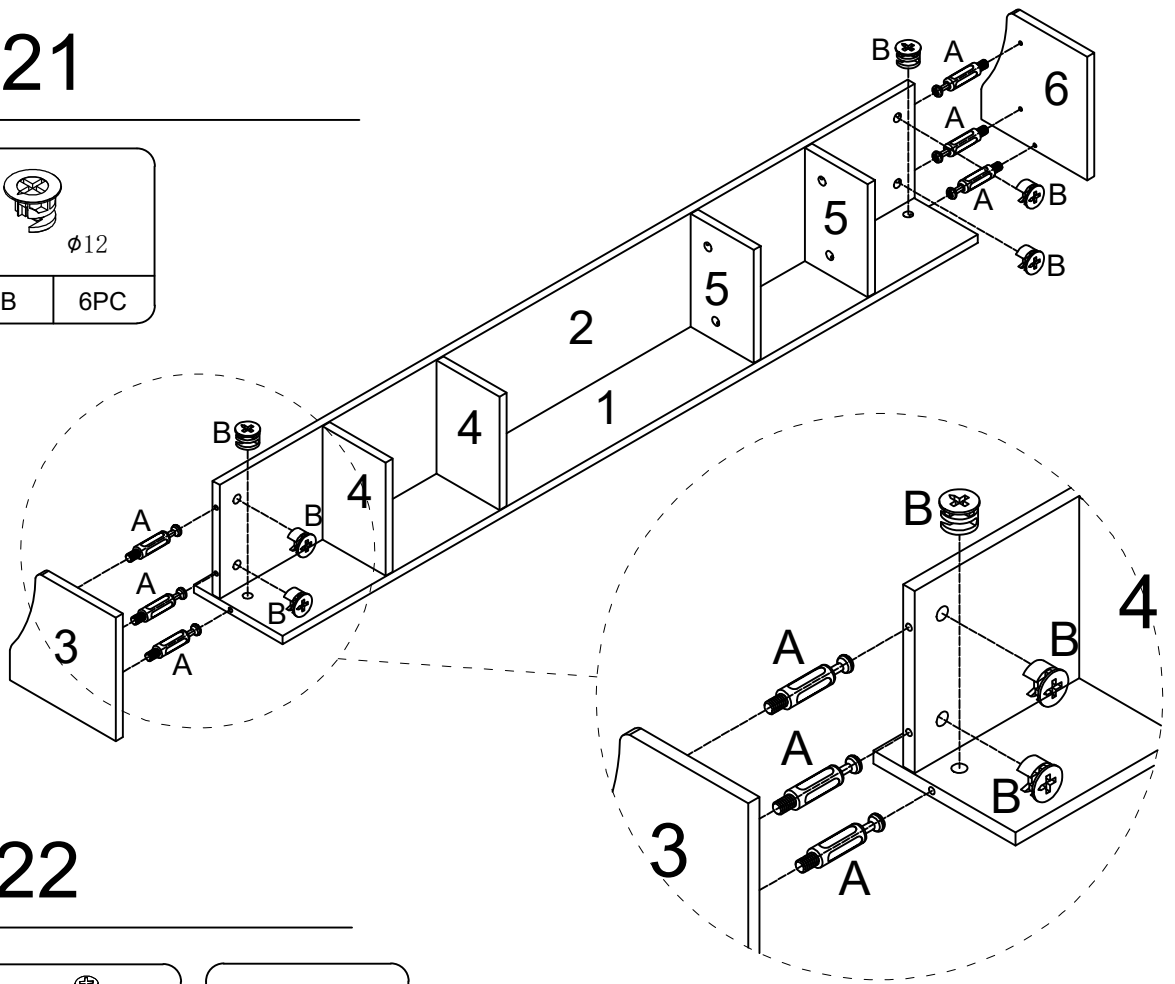
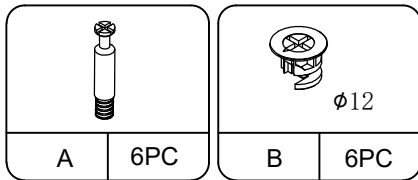

STEP 22

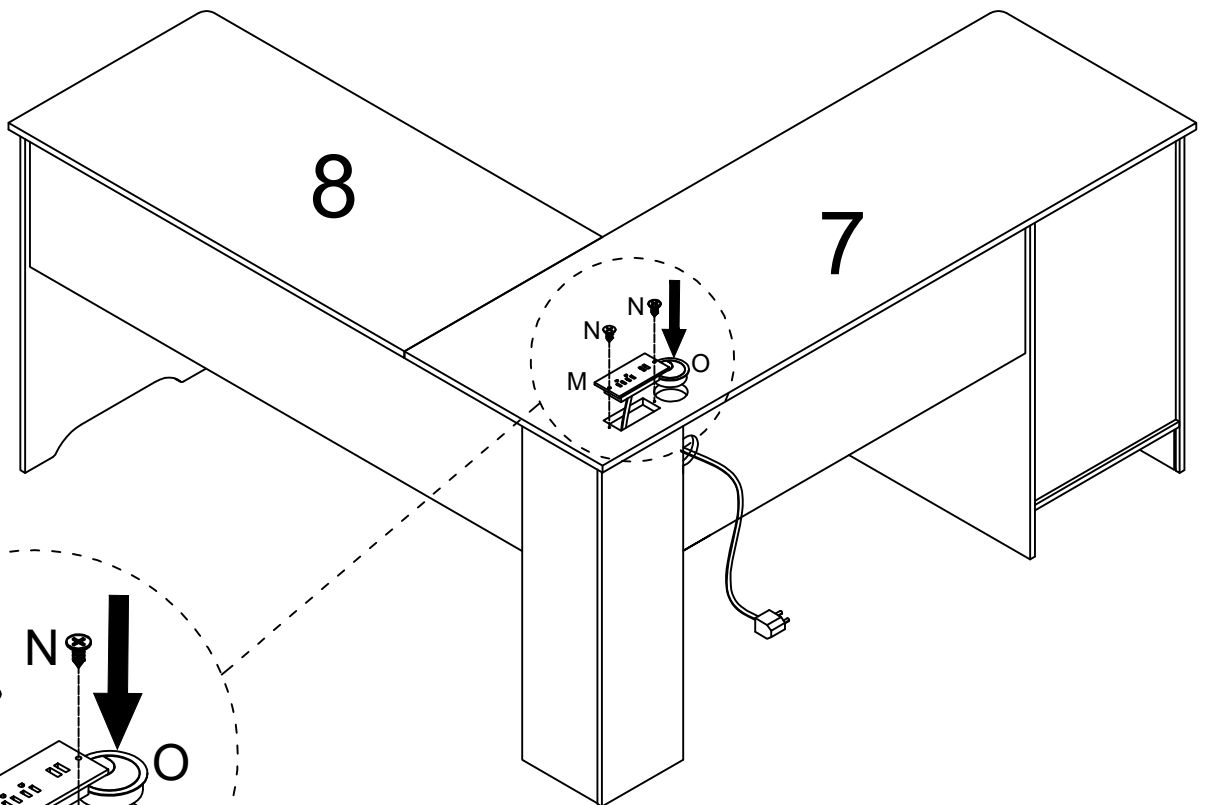
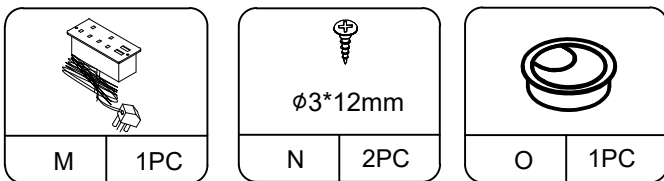

STEP 23

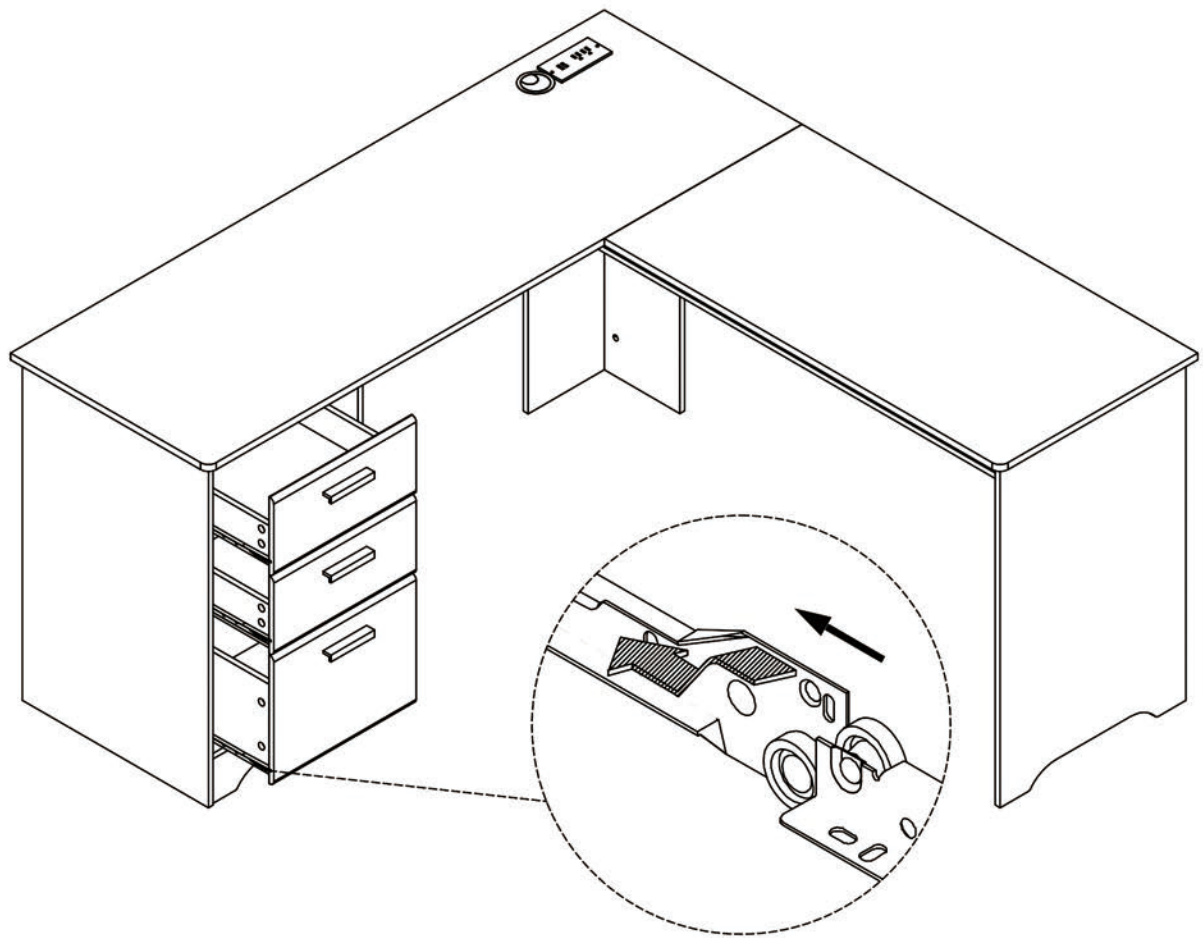

STEP 24

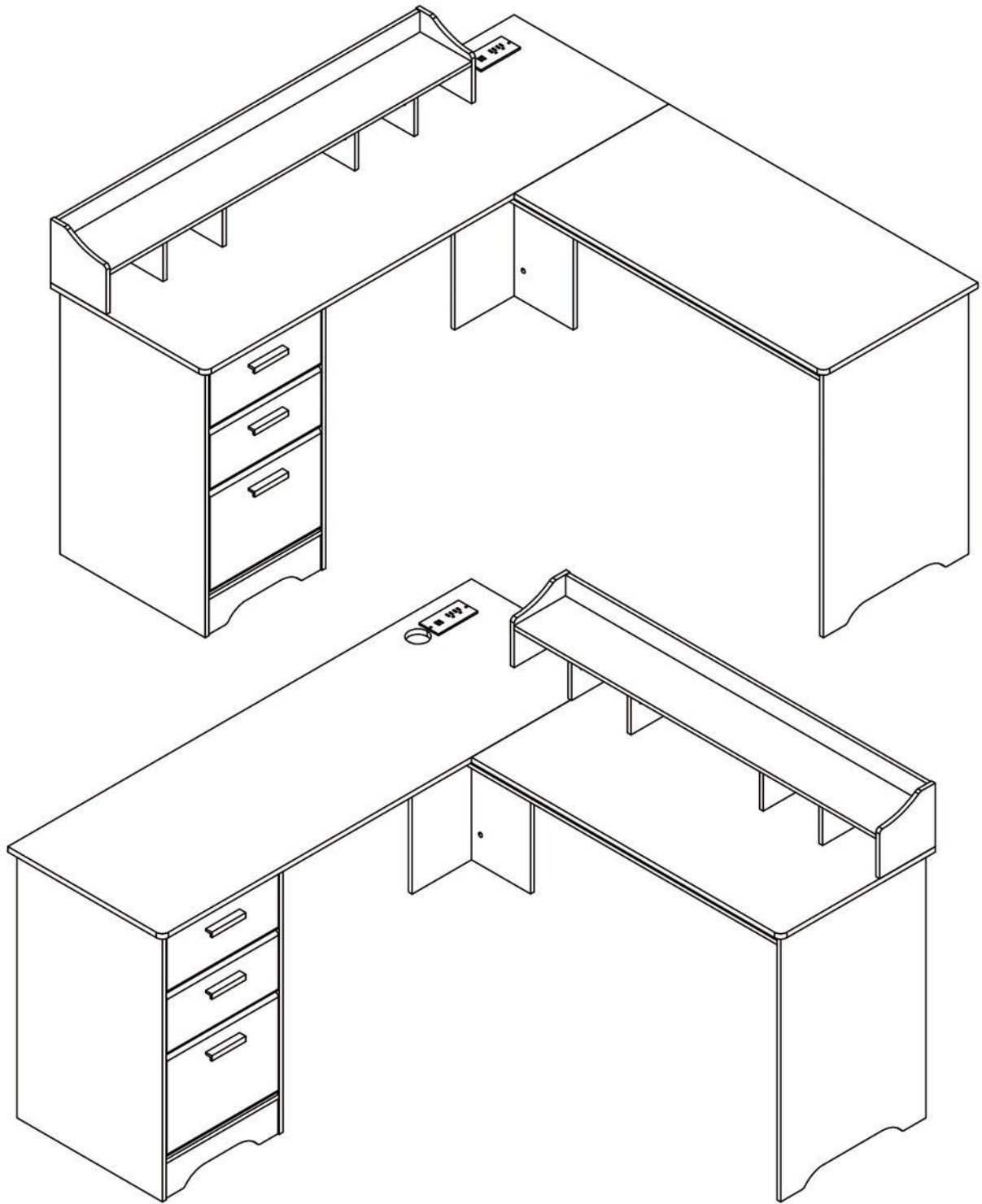

WARNING

Please make sure that all objects are removed before moving the assembled unit. The unit must be team lifted, not dragged or pushed. Failure to do so could cause instability, product collapse, and/or serious injury.