

ASSEMBLY INSTRUCTIONS



**TV
CONSOLE**

ASSEMBLY INSTRUCTIONS

ASSEMBLY TIPS:

1. Remove hardware from box and sort by size.
2. Please check to see that all hardware and parts are present prior to start of assembly.
3. Please follow attached instructions in the same sequence as numbered to assure fast & easy assembly.



WARNING!

1. Don't attempt to repair or modify parts that are broken or defective. Please contact the store immediately.
2. This product is for home use only and not intended for commercial establishments.





ASSEMBLY TIME

40 MINUTES

MAX TV SIZE: 65"

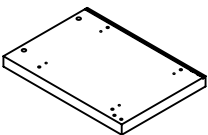
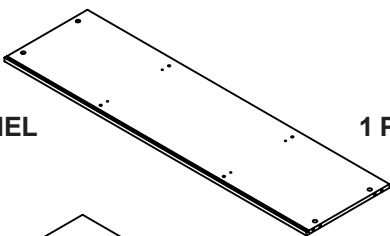
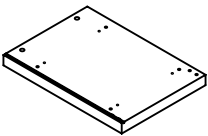
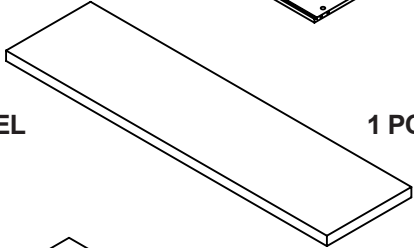
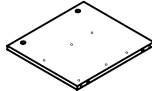
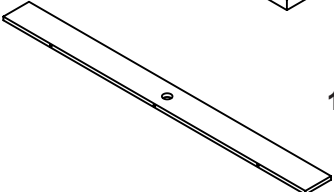
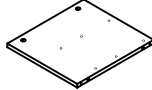
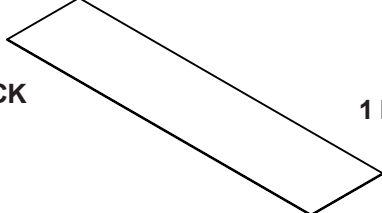
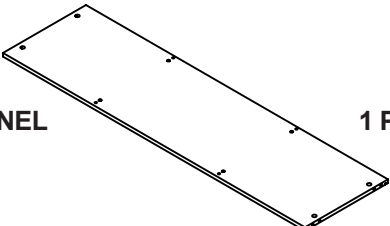
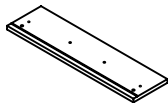
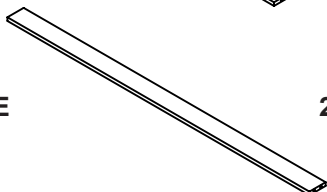
PARTS IDENTIFICATION

A	LEFT SIDE PANEL		1 PC	G	CROSS PANEL		1 PC
B	RIGHT SIDE PANEL		1 PC	H	TOP PANEL		1 PC
C	LEFT DIVIDE PANEL		1 PC	I	UPPER BACK PANEL		1 PC
D	RIGHT DIVIDE PANEL		1 PC	J	DOWN BACK PANEL		1 PC
E	BOTTOM PANEL		1 PC	K	DRAWER FRONT PANEL		2 PCS
F	CROSS BRACE		2 PCS	L	DRAWER BACK PANEL		2 PCS

NOTE:











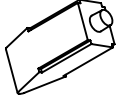

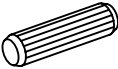
Phillips head screw driver is required in the assembly process; however, manufacturer does not provide this item.

M LEFT DRAWER SIDE PANEL  2 PCS

O DRAWER BOTTOM PANEL  2 PCS

N RIGHT DRAWER SIDE PANEL  2 PCS

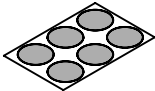
Z HARDWARE IDENTIFICATION

NO	DESCRIPTION	FIGURE	Q'TY	NO	DESCRIPTION	FIGURE	Q'TY
1	GLUE 40g		1 PC	8	GLIDES L = 350mm		2 SET
2	WOODEN DOWEL Ø 8x30mm		42 PCS	9	GLIDES SCREW Ø 3x12mm		24 PCS
3	CAM BOLT Ø 7x35.5mm		20 PCS	10	HANDLE		2 PCS
4	CAM LOCK Ø15x12mm		20 PCS	11	HANDLE BOLT M5x25mm		4 PCS
5	SCREW Ø 4.5x42mm		4 PCS	12	NUT M5		4 PCS
6	DRAWER SCREW Ø 4.3x35mm		8 PCS	13	STICKER Ø 20mm		4 PCS
7	PLASTIC FEET Ø 15mm		6 PCS				

Z8,Z10,Z11,Z12 not included in blister packaging.

NOTE:

Phillips head screw driver is required in the assembly process; however, manufacturer does not provide this item.

STEP 2

Apply glue on all wooden dowels to ensure integrity of the structure.

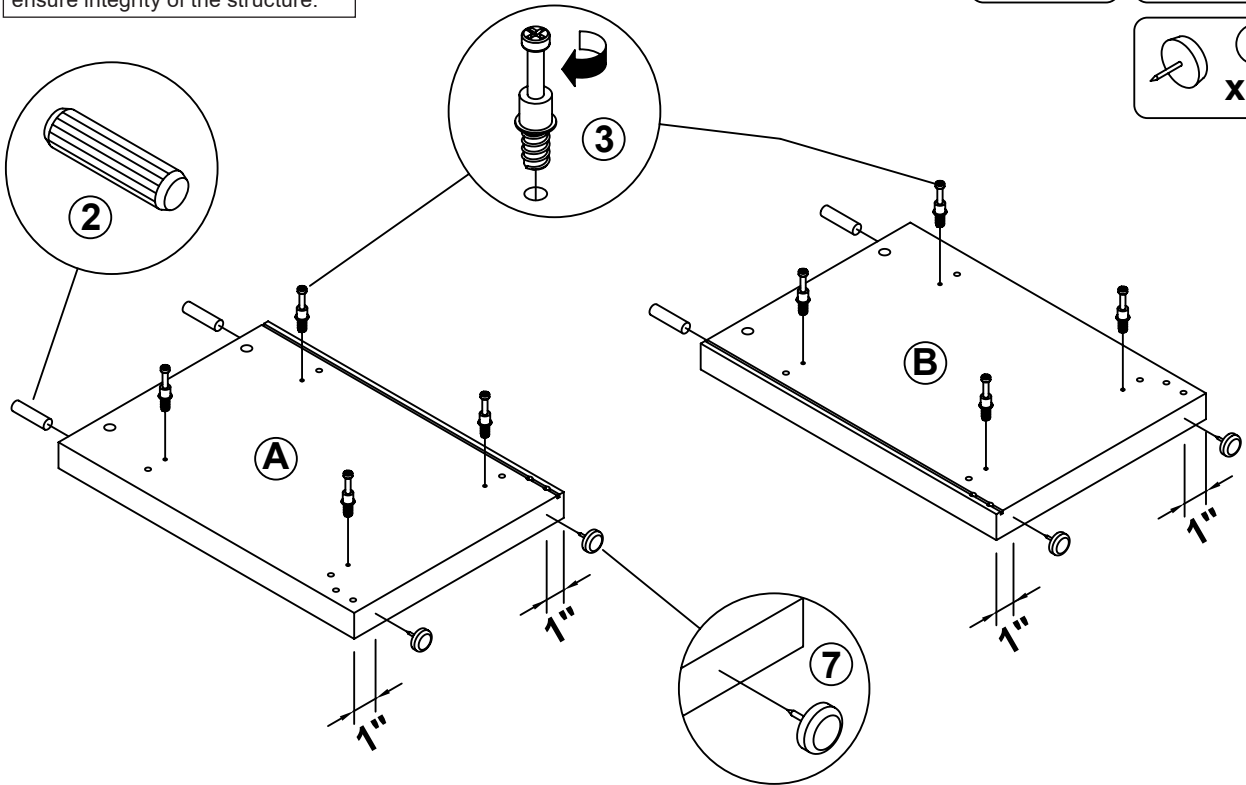
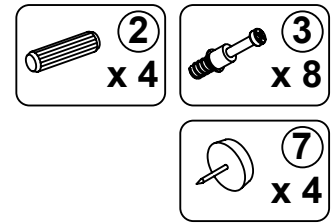

STEP 3

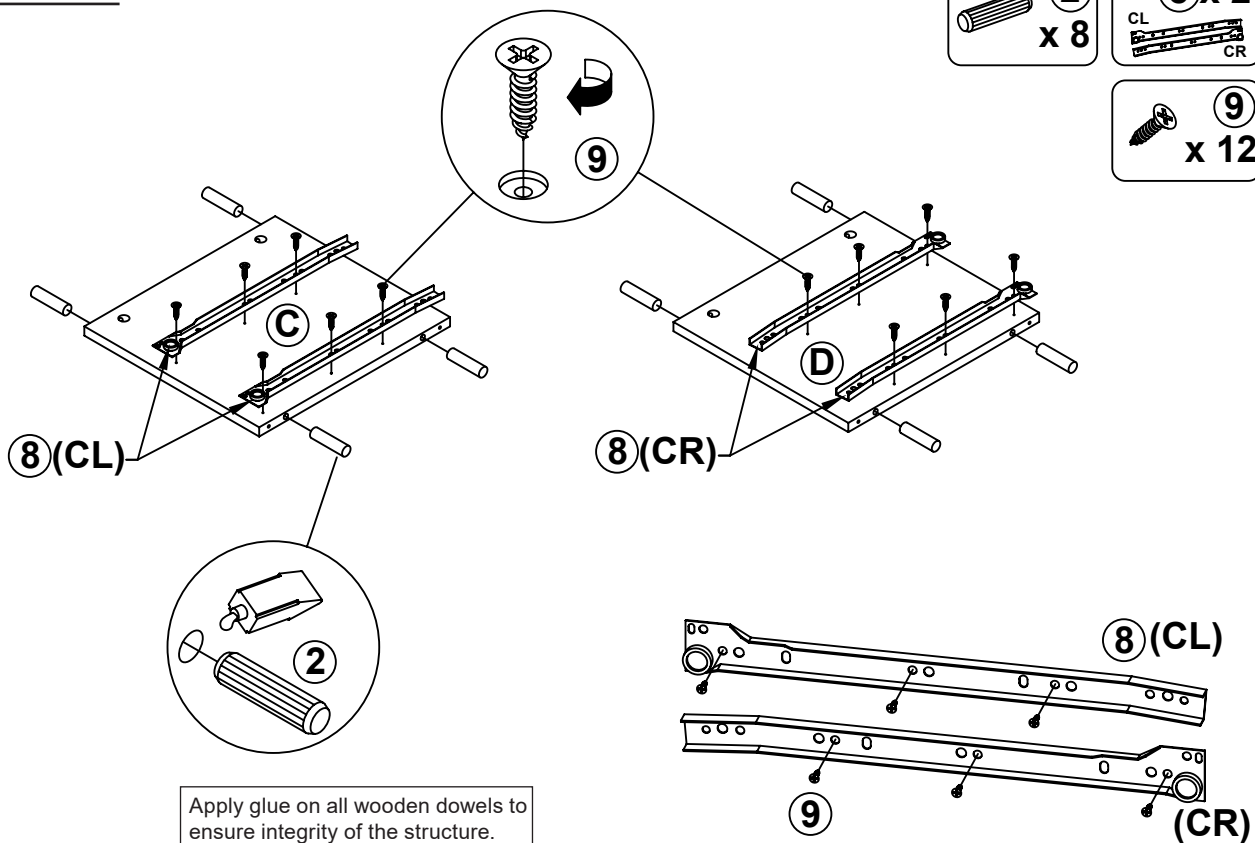
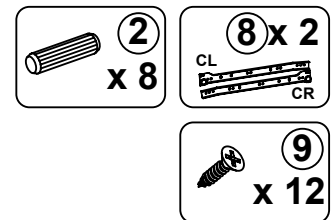

Apply glue on all wooden dowels to ensure integrity of the structure.

STEP 4

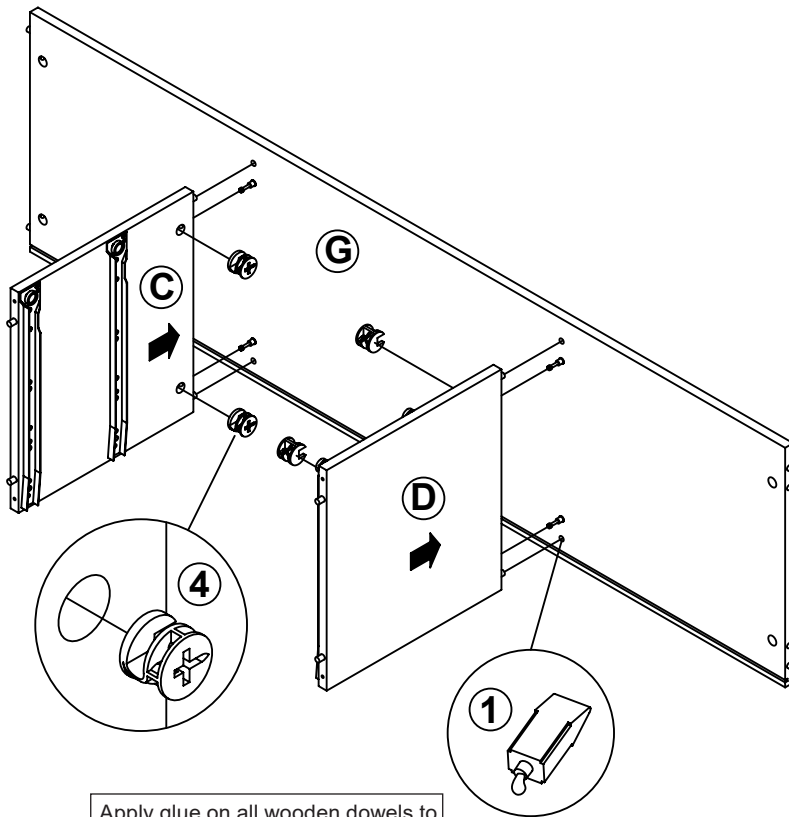
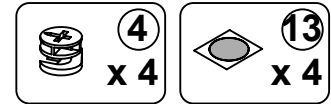

Apply glue on all wooden dowels to ensure integrity of the structure.

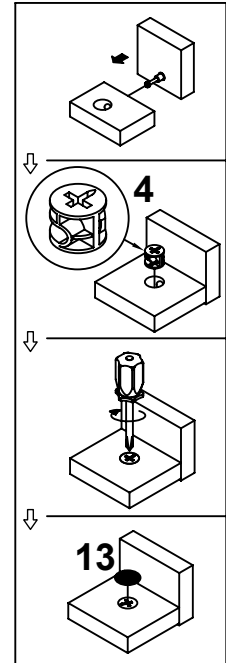

STEP 5

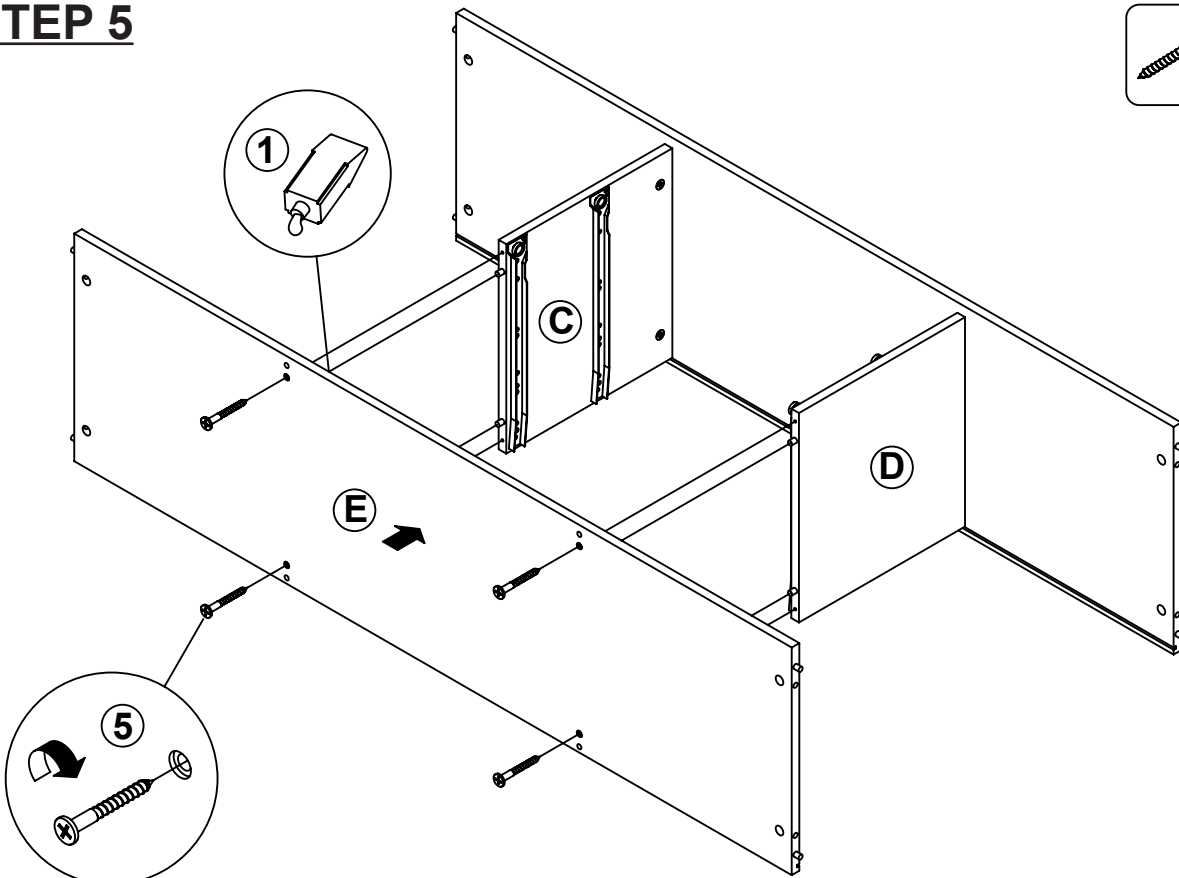
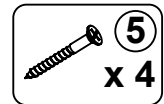

STEP 6

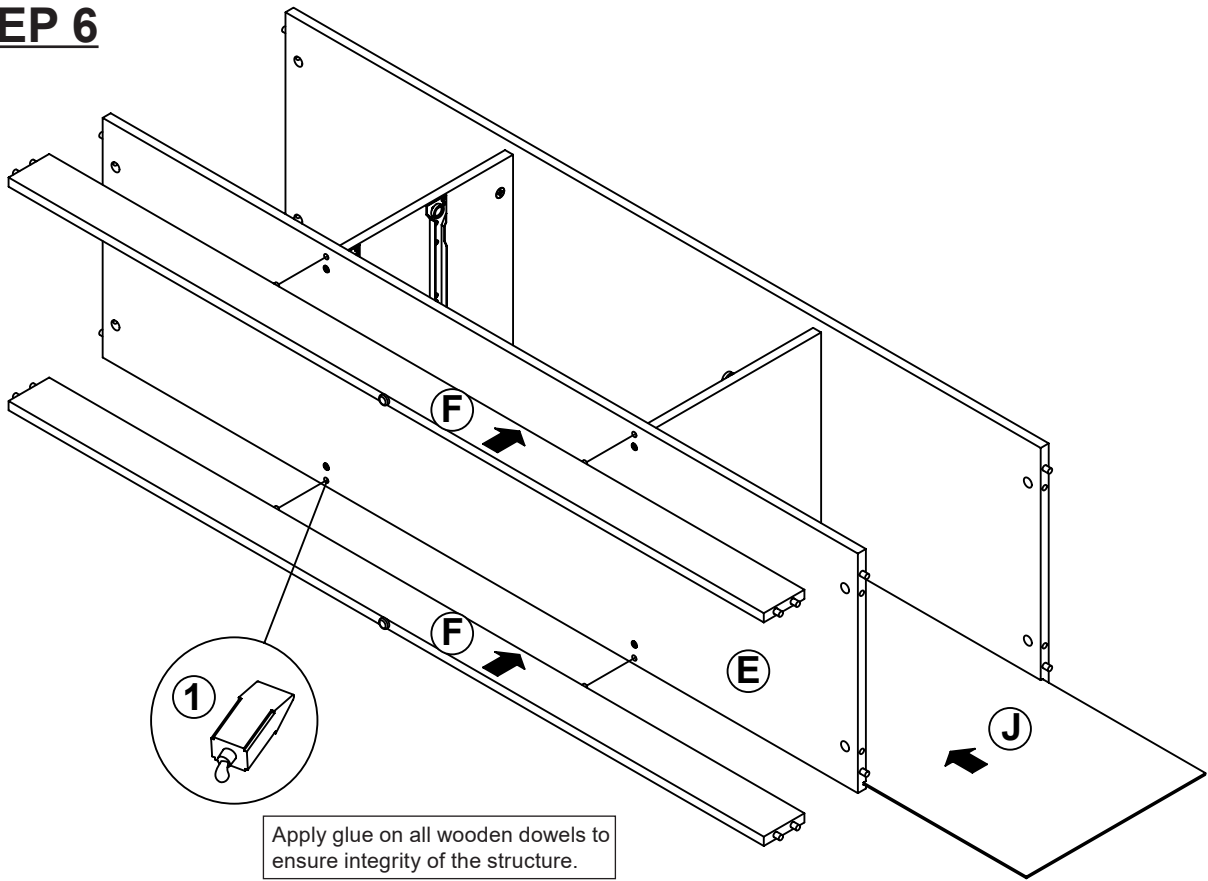

STEP 7

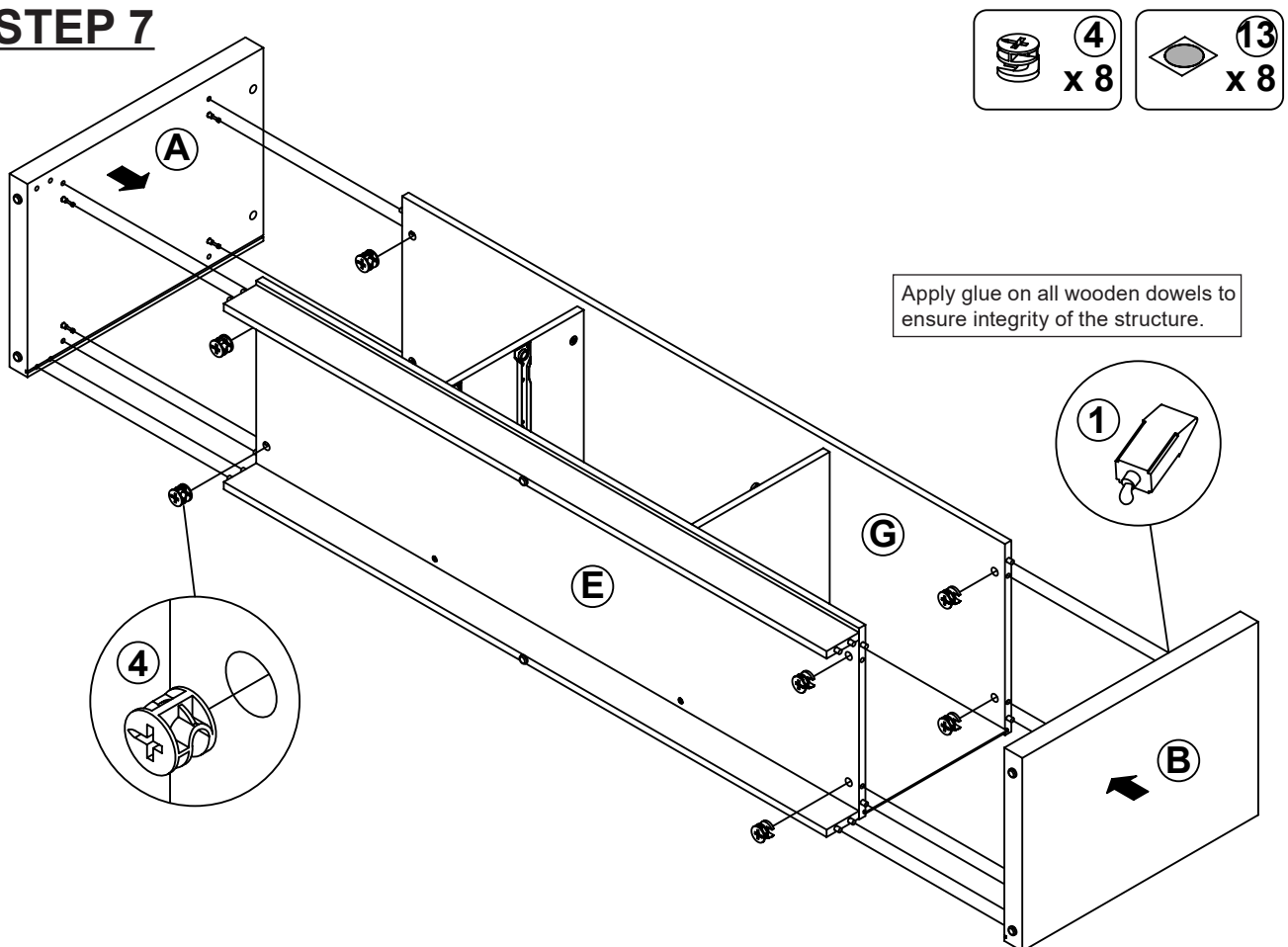

STEP 8

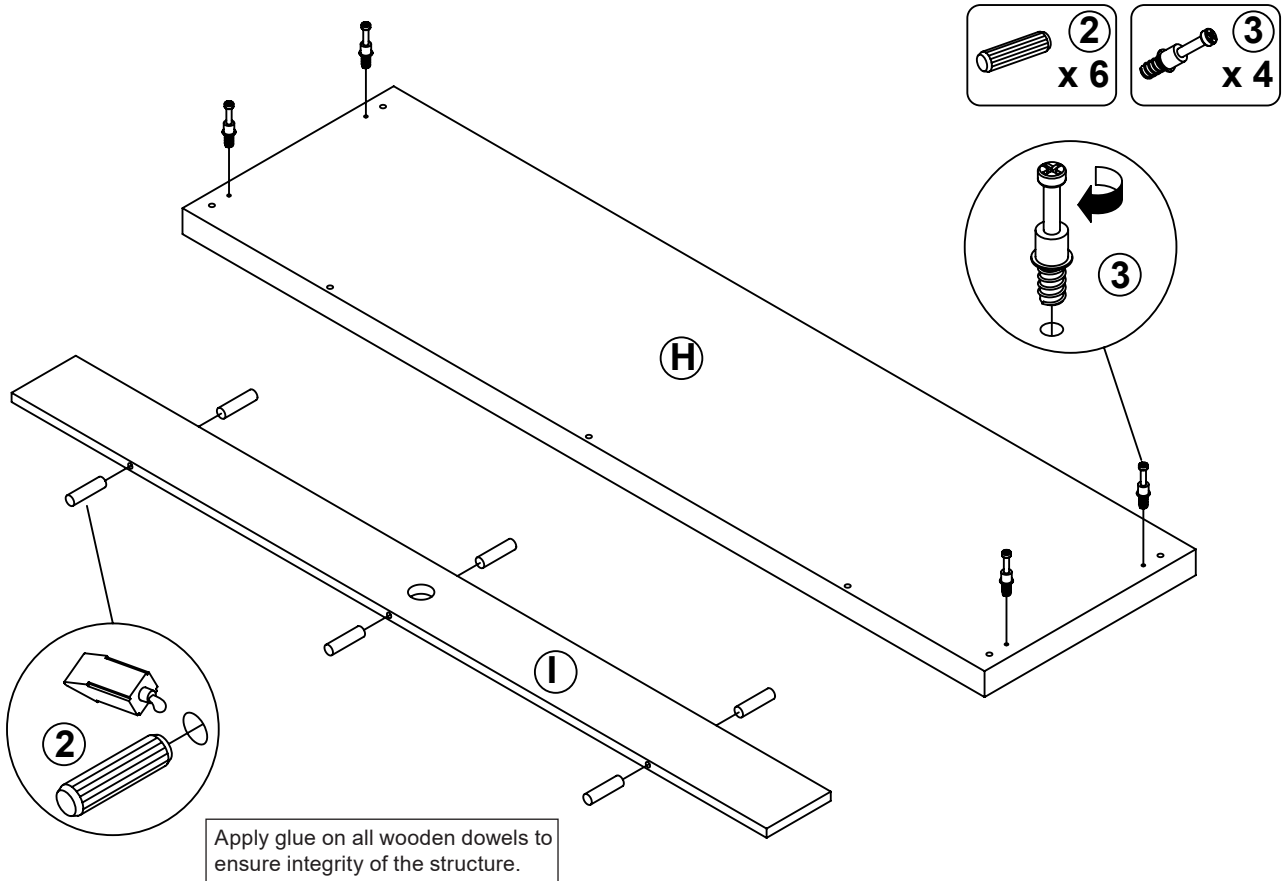

STEP 9

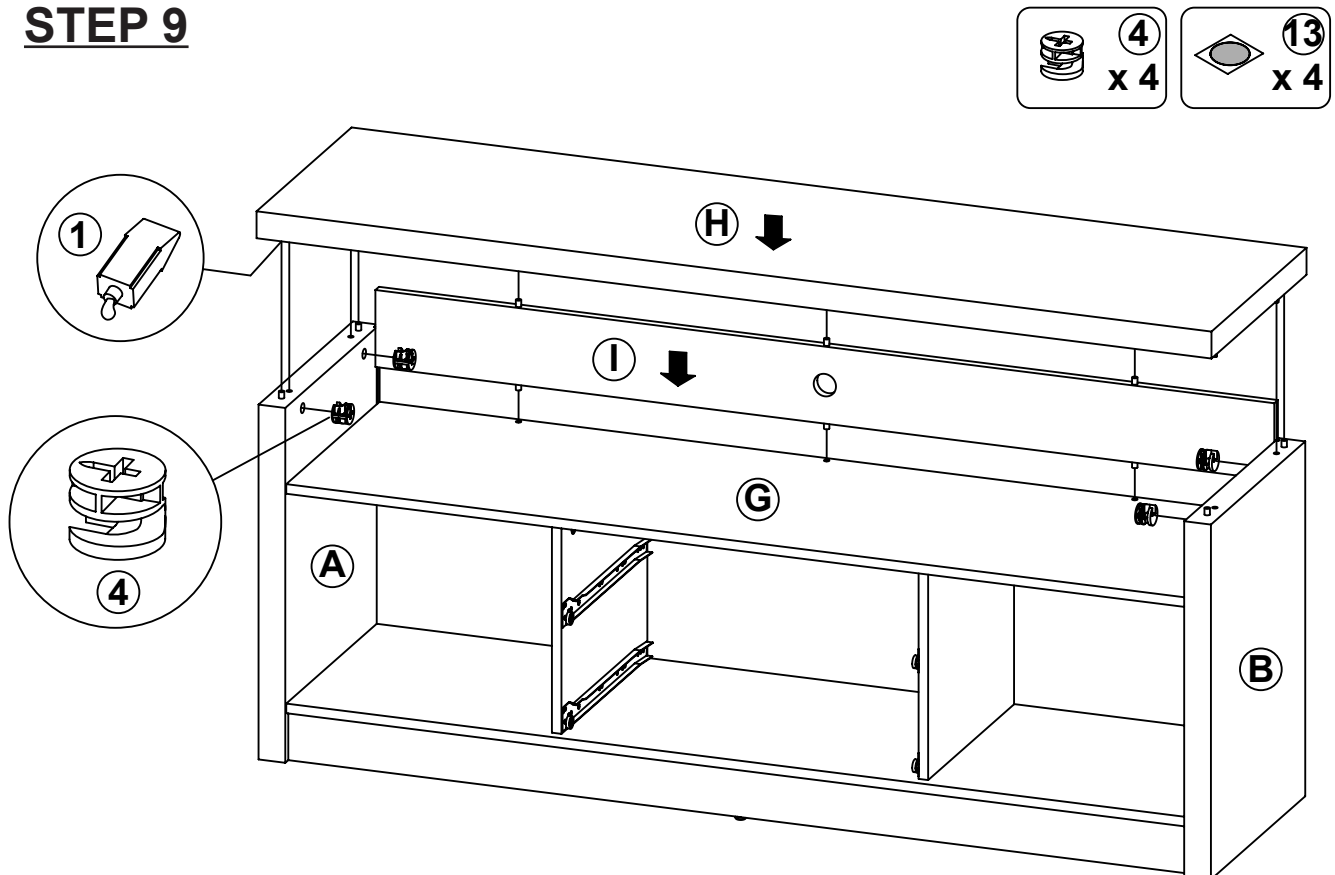

STEP 10-1

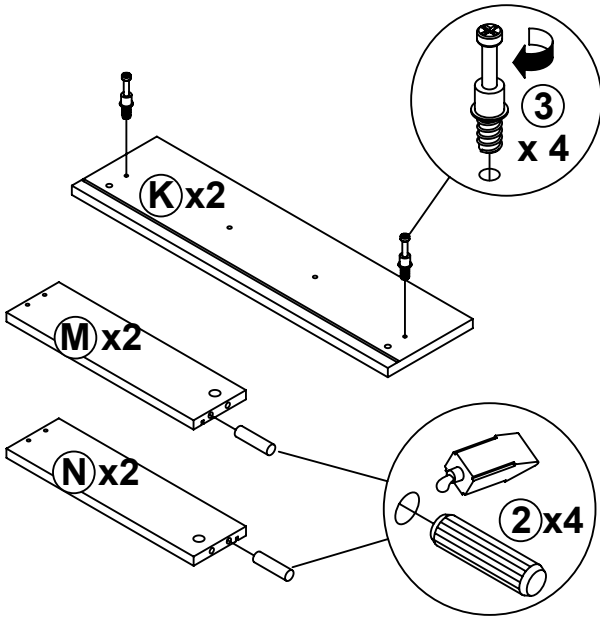

STEP 10-2

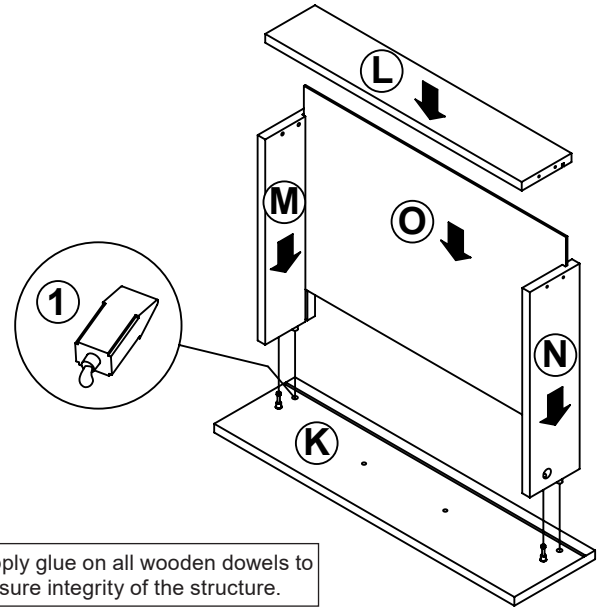

Apply glue on all wooden dowels to ensure integrity of the structure.

STEP 10-3

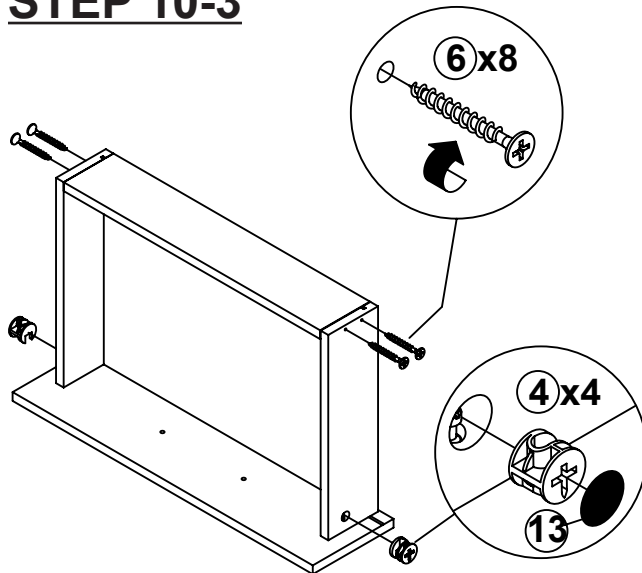

STEP 10-4

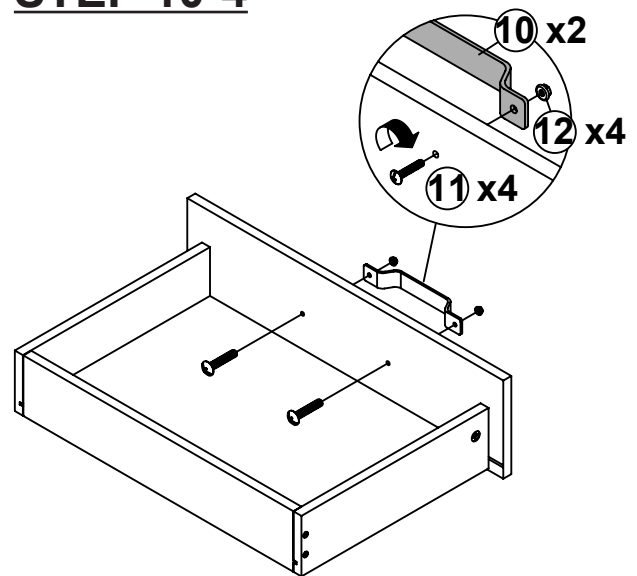

STEP 10-5

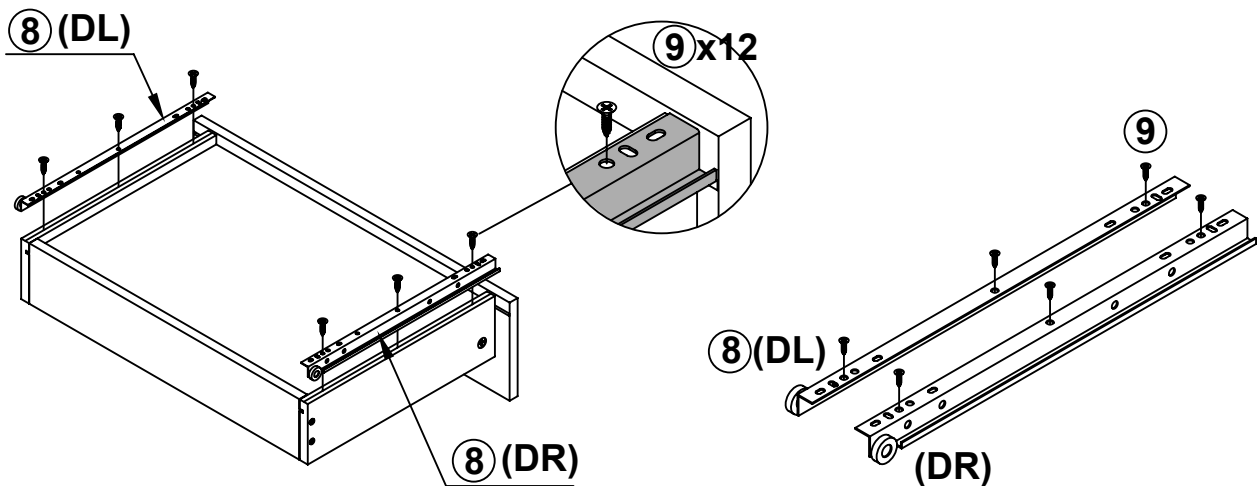

STEP 11

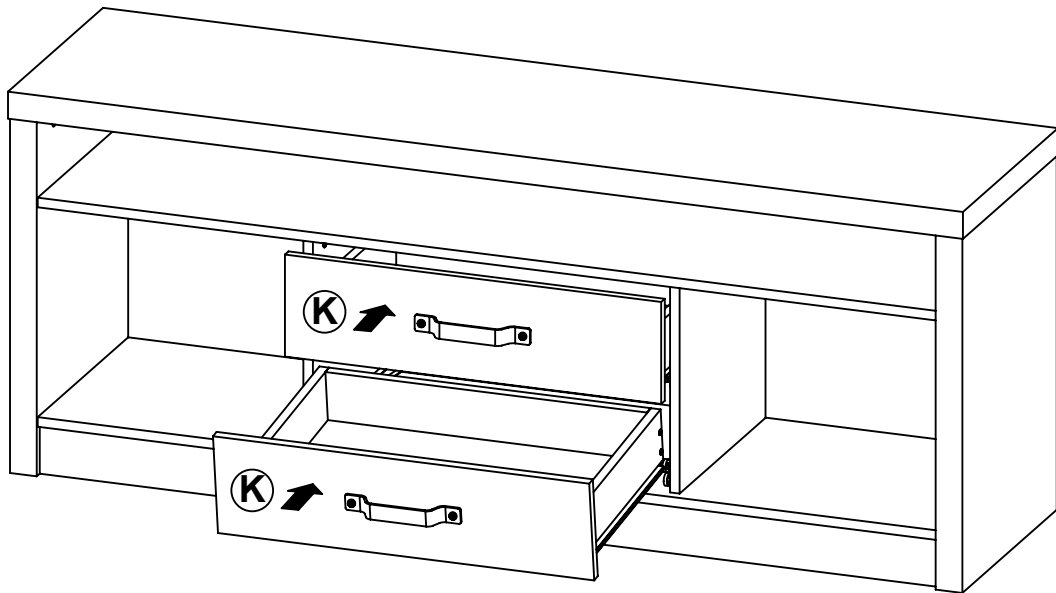

STEP 12

COMPLETE

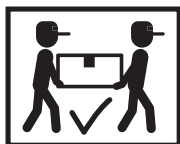
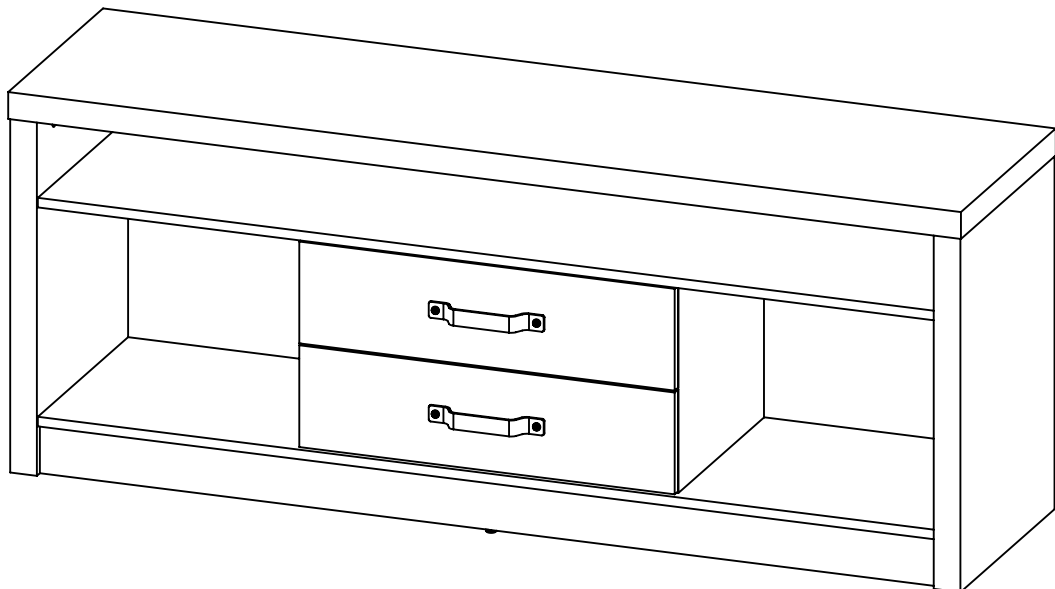

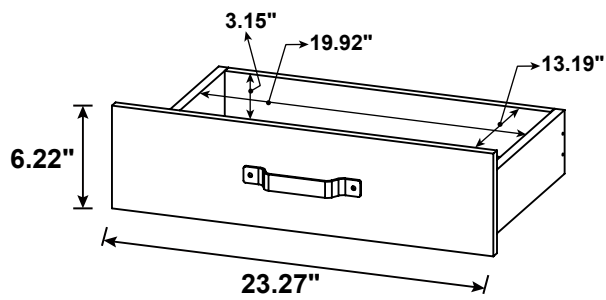
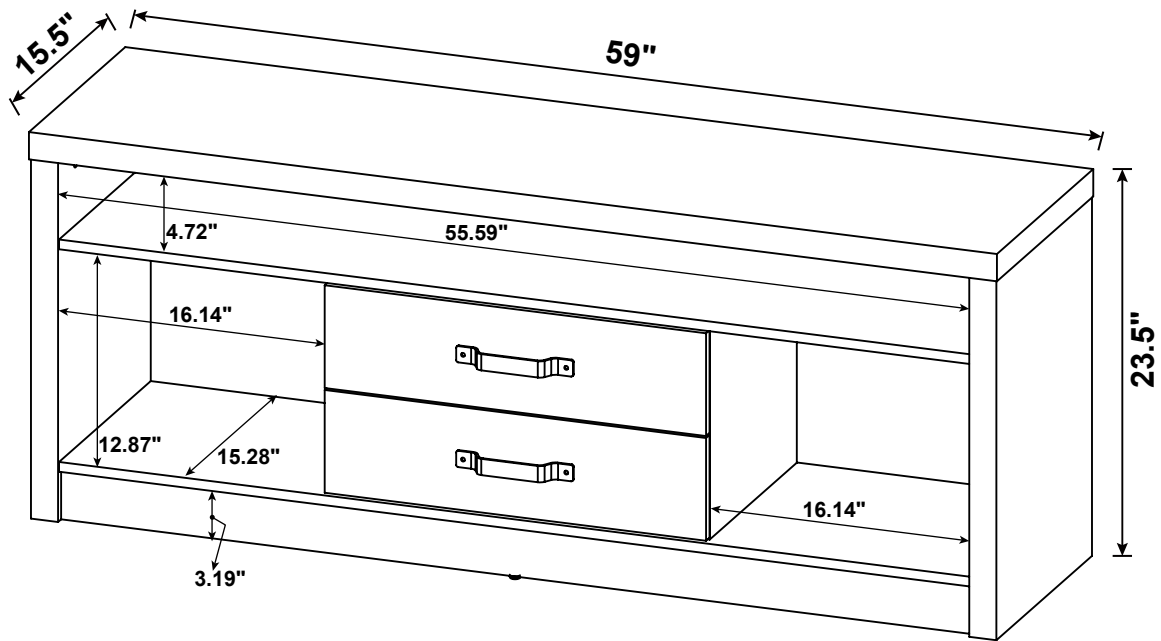

Note : Dimension tolerance $\pm 5\%$