

Wood Platform Bed

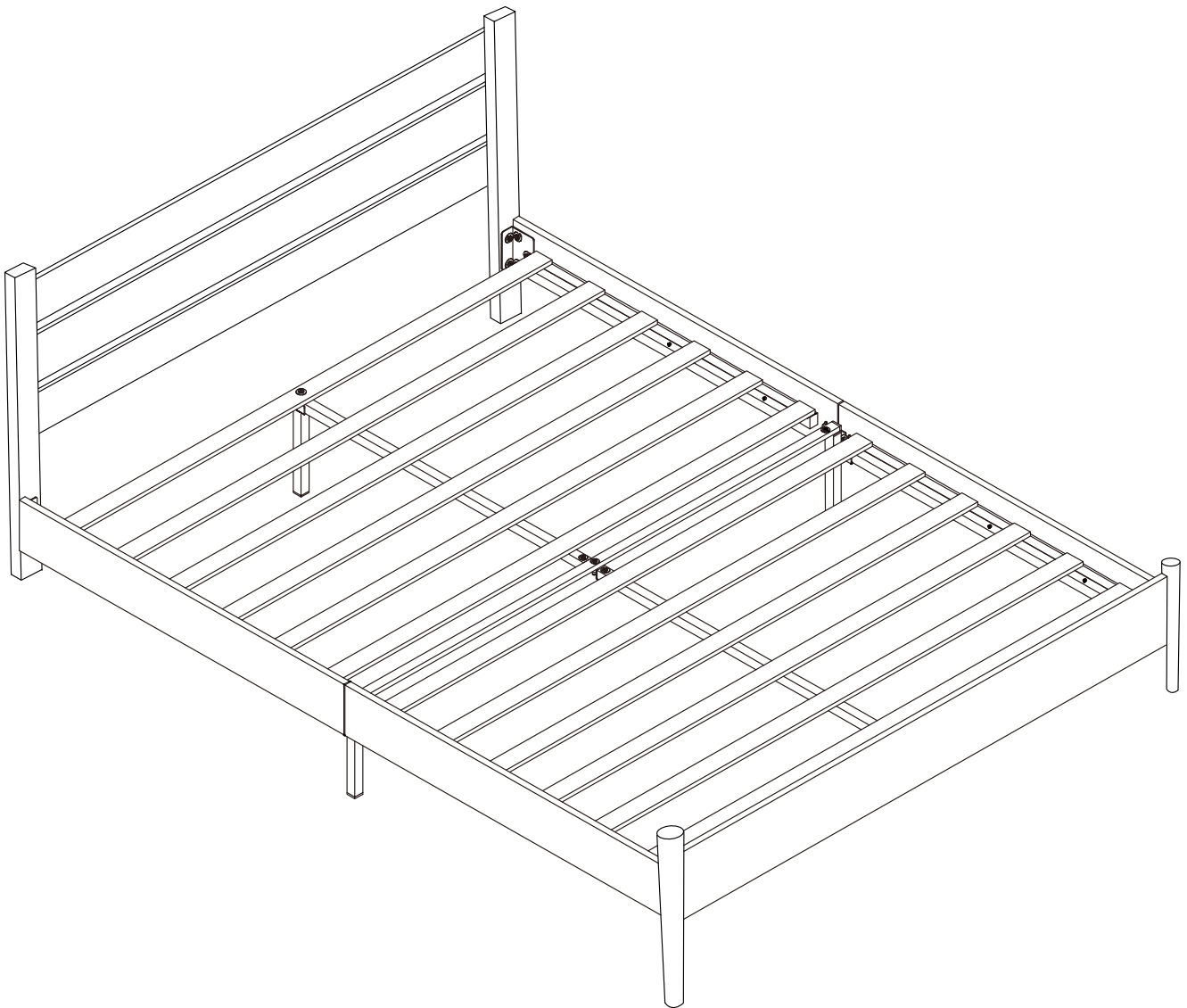

Dear Customers,

Thank you for purchasing our product. Please read this instruction manual carefully after receiving this product. It will help you assemble this product quickly, safely and correctly. You can keep this manual for future reference.

! IMPORTANT

Please follow the instruction manuals and use a pad to protect the product during your assembly.

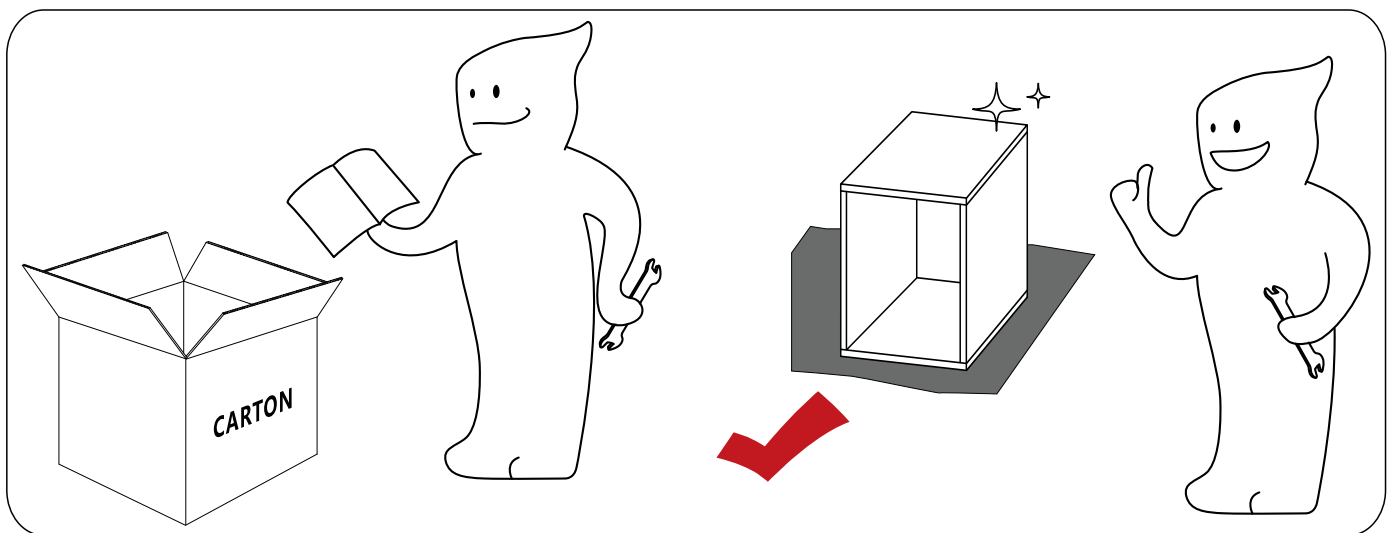
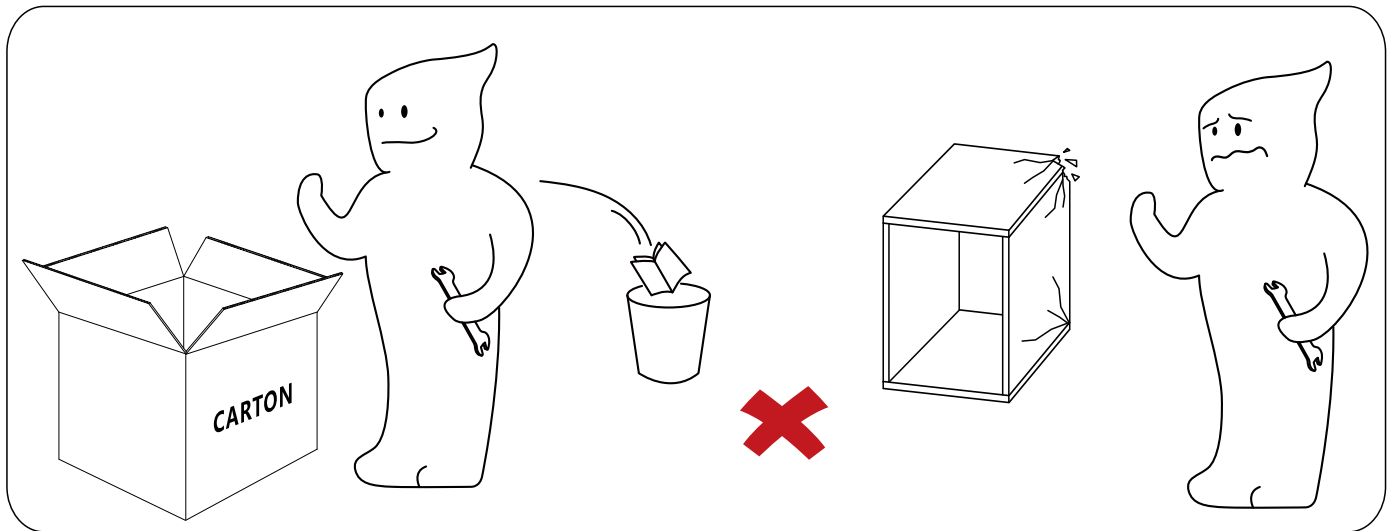















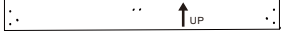
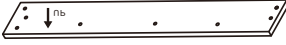

Note:

1. Should be assembled on flat ground to keep balance.
2. Before completing the installation, do not tighten the screws.
3. **Finally, tighten all the screws manually.**

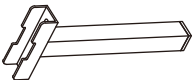

For easier and better assembly, **2** or more adults are required.

ASSEMBLY INSTRUCTIONS

ALPHABETICAL NUMBERING	DESCRIBE	ILLUSTRATION	NUMBER
A	Slat		1pc
B	Slat		1pc
C	Down headboard		2pcs
C1	Connector wood		2pcs
C2	Connector wood		2pcs
C3	Up headboard		1pc
D	Headboard leg		1pc
D1	Headboard leg		1pc
E	Footboard		1pc
F	Side panel		2pcs
F1	Side panel		2pcs
G	Support bar		1pc
H	Support bar		1pc
I	Support bar		1pc
J	Support wood		4pcs
K	Support leg		2pcs
L	Support leg		2pcs
M	Wood leg		2pcs

ASSEMBLY INSTRUCTIONS

Ruler-Use this ruler to help correctly identify the screws.

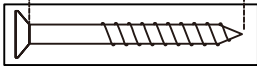

The length of the screw is measured from the rod part excluding the screw cap (30mm screw shown).

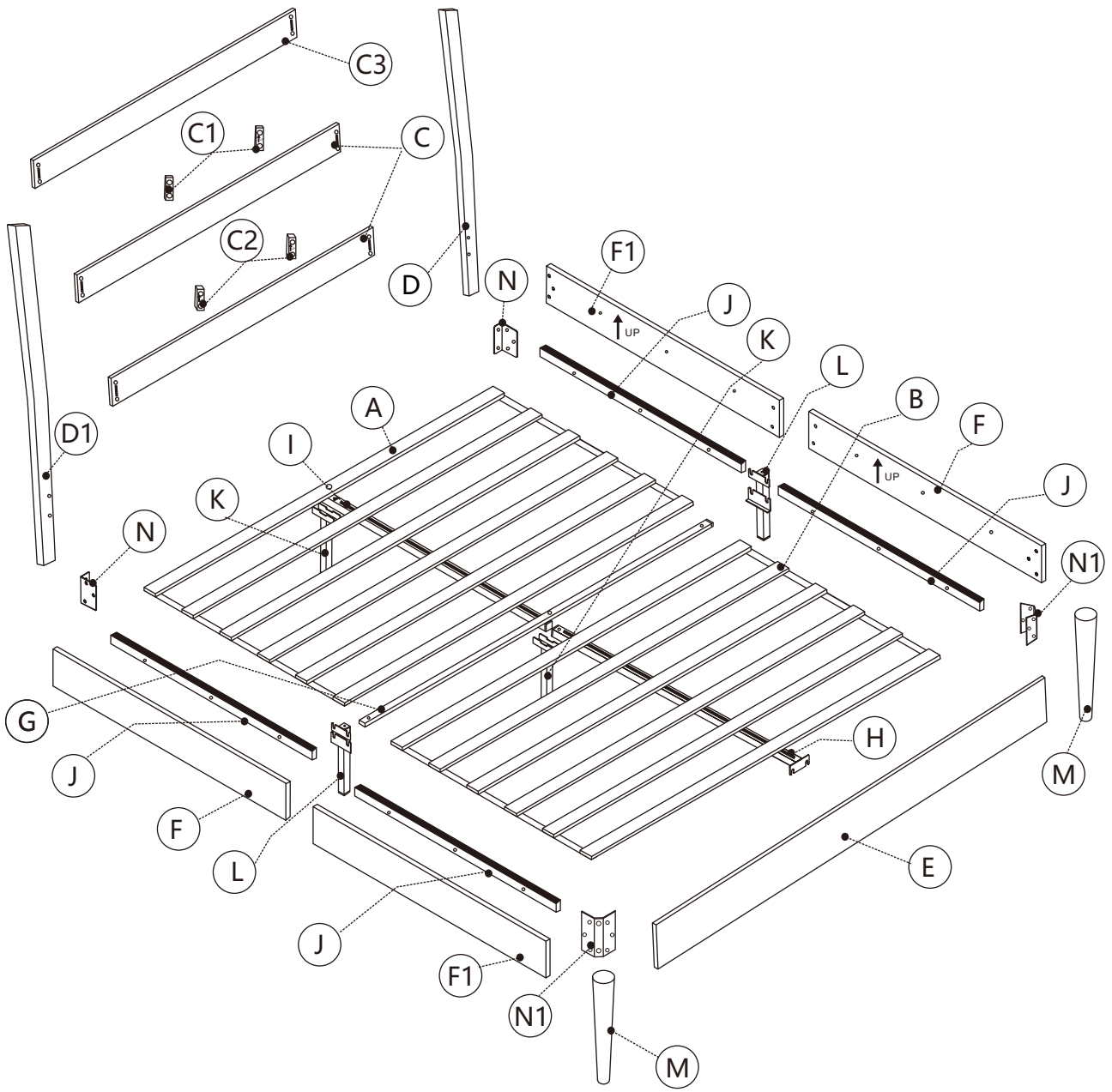

ALPHABETICAL NUMBERING	DESCRIBE	ILLUSTRATION	NUMBER
N	Connector plate 100x2 mm		2pcs
N1	Connector plate 100x2 mm		2pcs
O	Sponge-cushion		4pcs
P	Washer φ8x18x1.5 mm		74pcs+1pc
Q	Wrench M6		1pc
R	Screw M8x50 mm		1pc
R1	Screw M8x35 mm		25pcs+1pc
R2	Screw M8x30mm		12pcs
R3	Screw M8x25 mm		8pcs
R4	Screw M8x16 mm		28pcs+1pc

ASSEMBLY INSTRUCTIONS



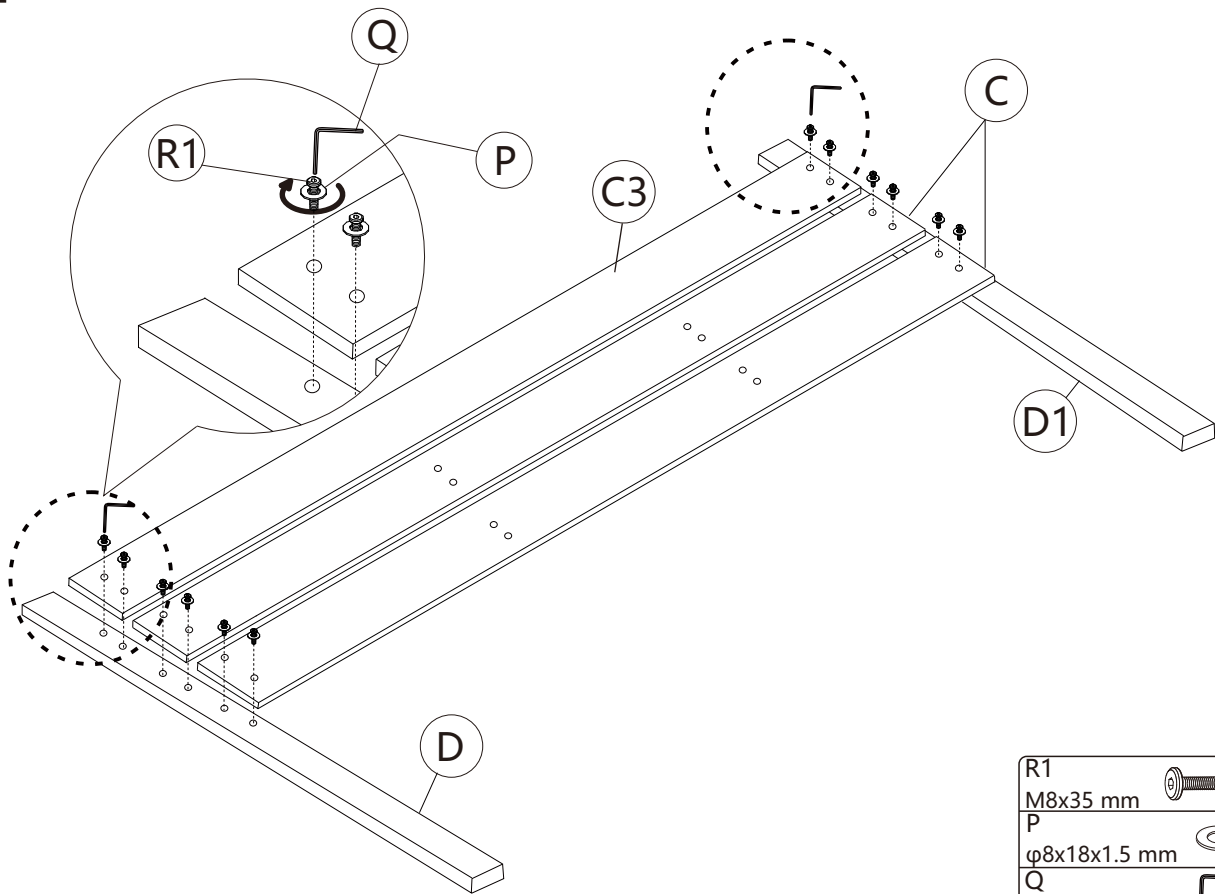



1 Tight all the inner screw after all holes are aligned.

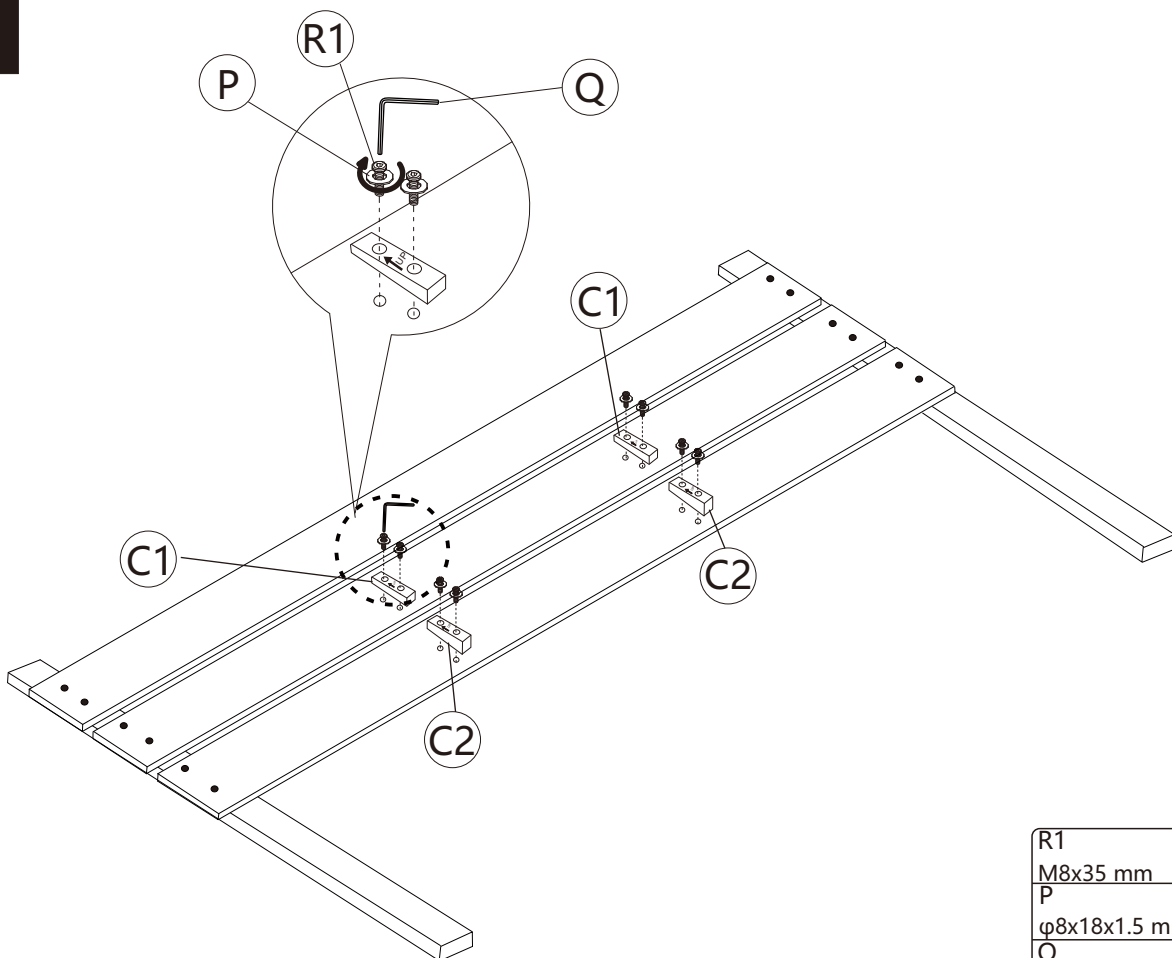

R1		12pcs
M8x35 mm		
P		12pcs
φ8x18x1.5 mm		
Q		1pc
M6		

2



R1		8pcs
M8x35 mm		
P		8pcs
φ8x18x1.5 mm		
Q		1pc
M6		

ASSEMBLY INSTRUCTIONS

3

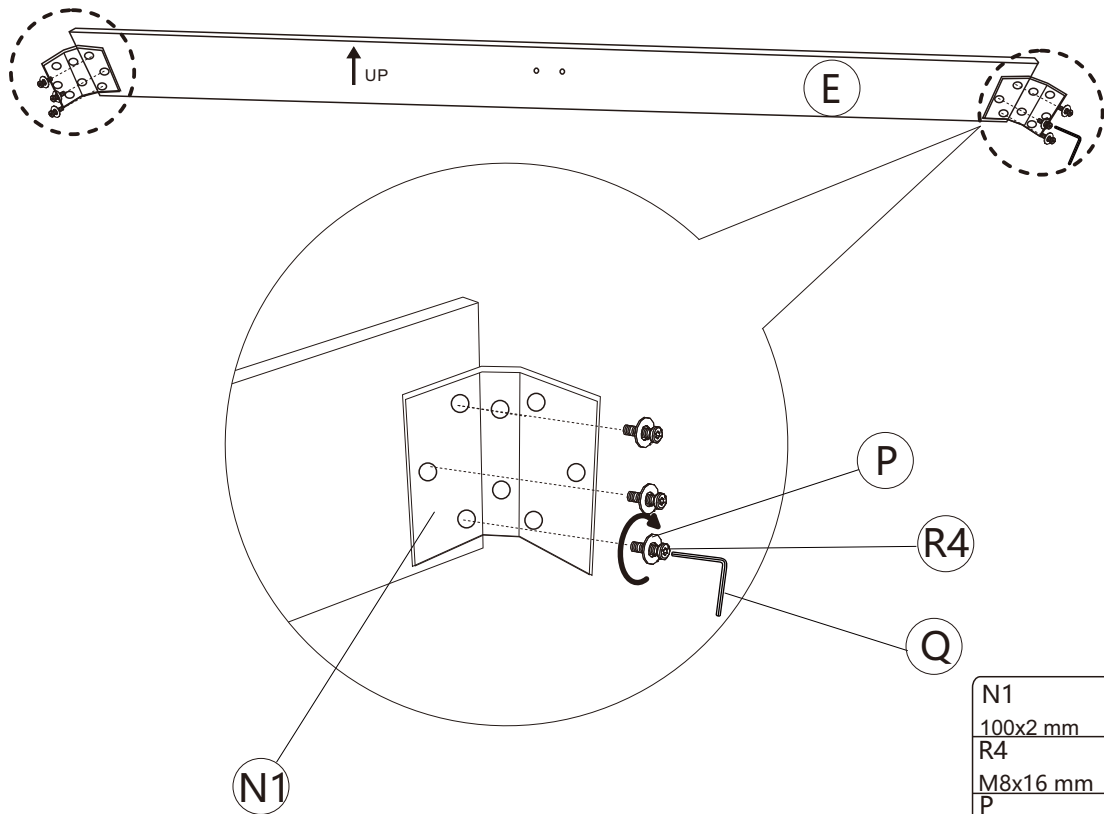

N1		2pcs
100x2 mm		
R4		6pcs
M8x16 mm		
P		6pcs
φ8x18x1.5 mm		
Q		1pc
M6		

4

Take out parts F and F1, and lock the iron frame foot L in the middle according to the figure. Note that there are **2 holes** located on the inner side of the board. Then lock the bed hanging piece N on the front and rear of the board, with **3 holes** on each side.

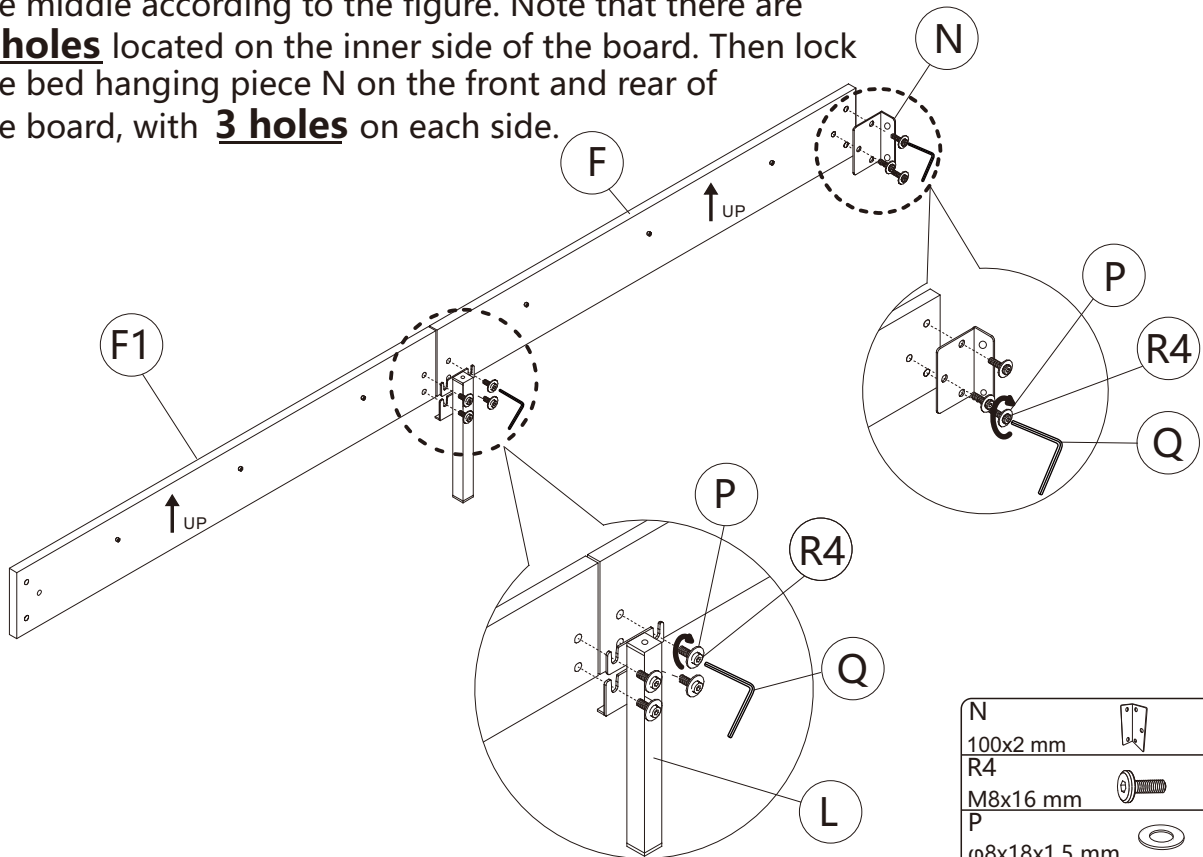

N		1pc
100x2 mm		
R4		7pcs
M8x16 mm		
P		7pcs
φ8x18x1.5 mm		
Q		1pc
M6		

5 Same as Step 4.

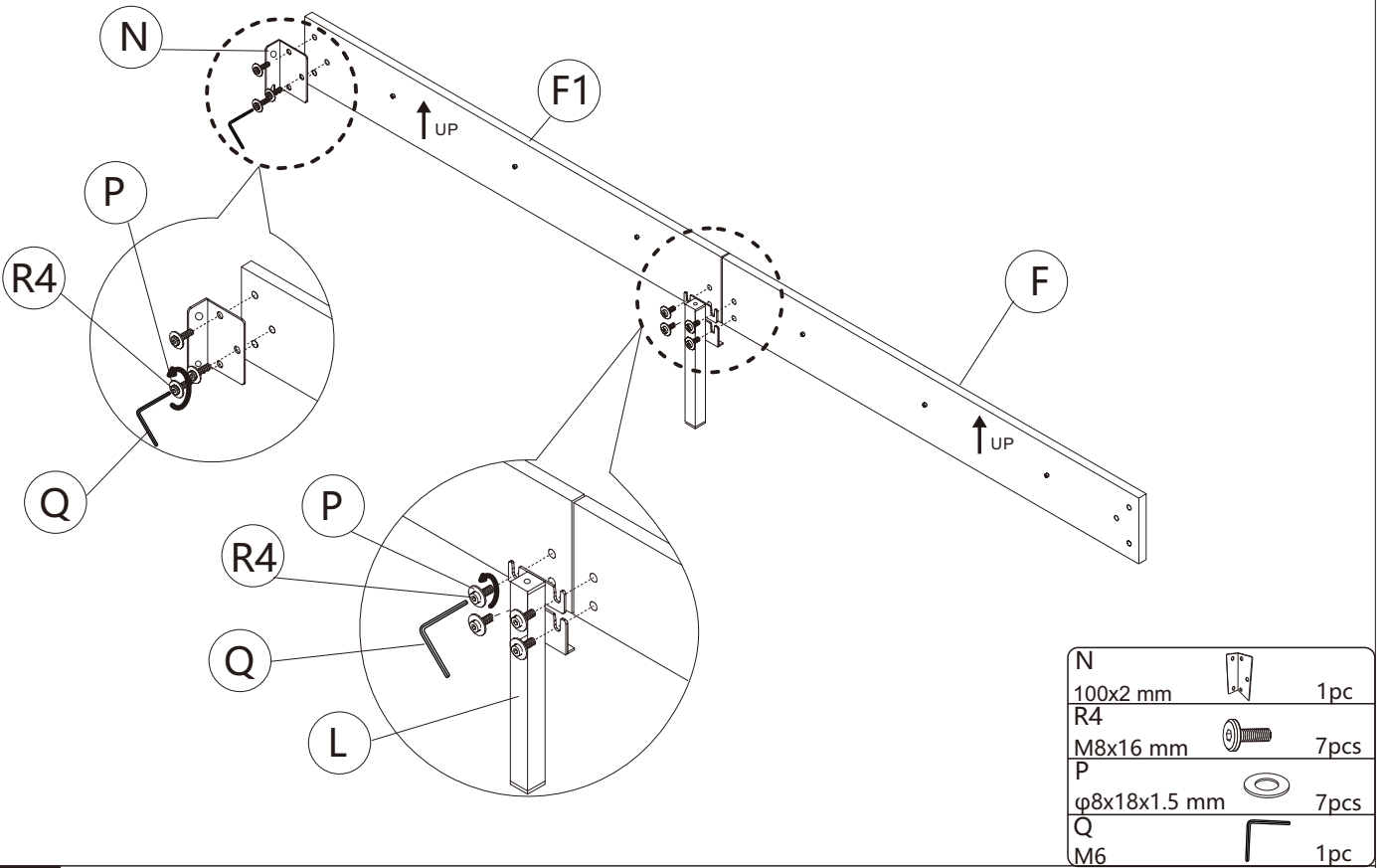



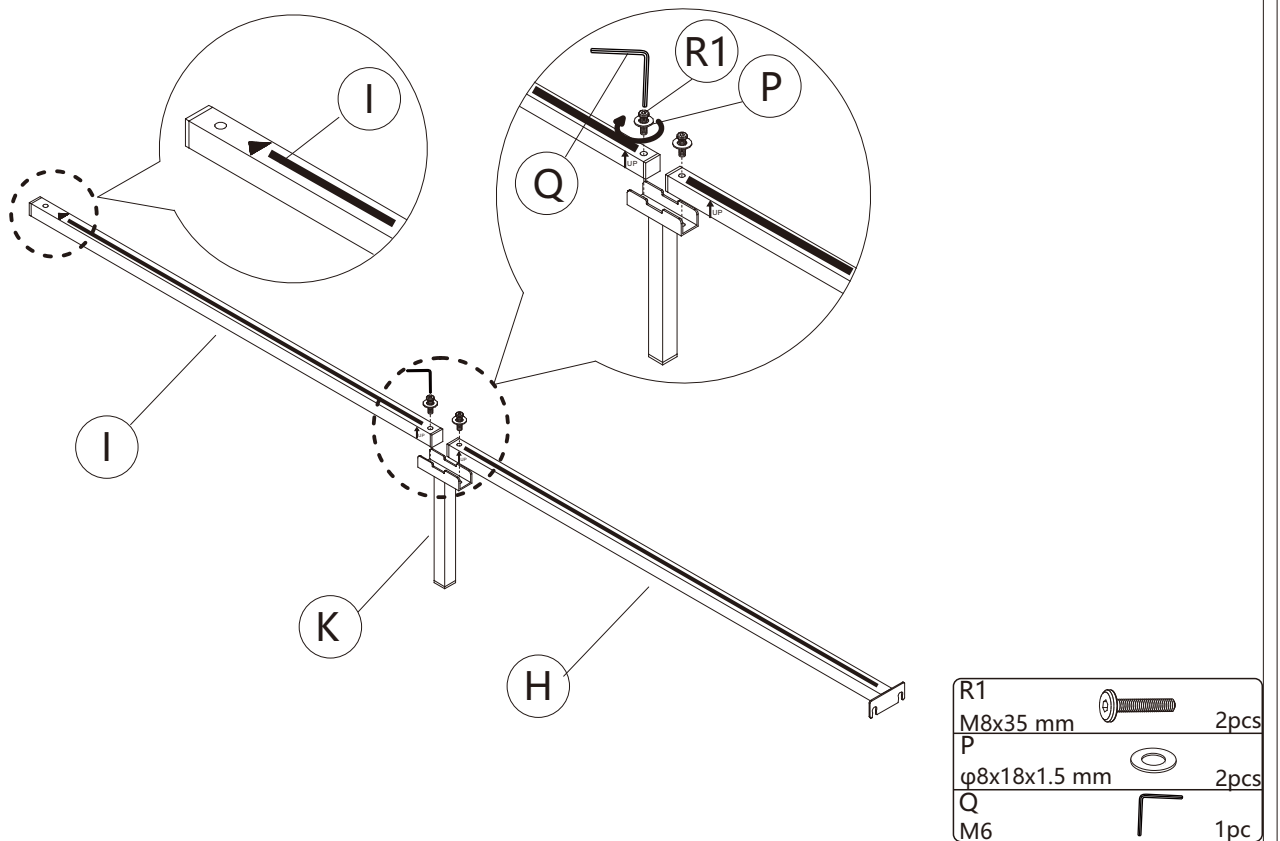

6

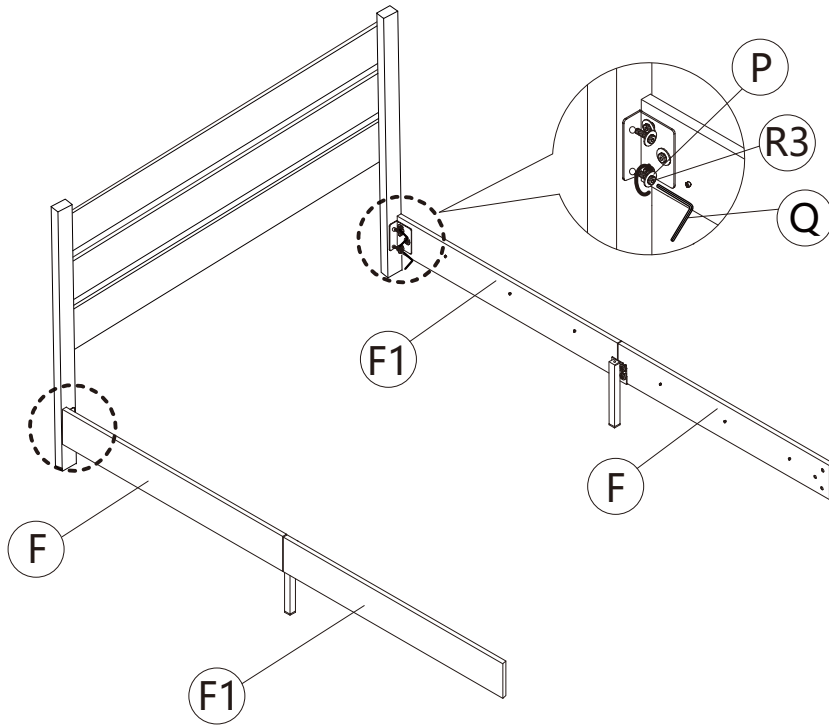

ASSEMBLY INSTRUCTIONS



7



R3		4pcs
M8x25 mm		
P		4pcs
φ8x18x1.5 mm		
Q		1pc
M6		

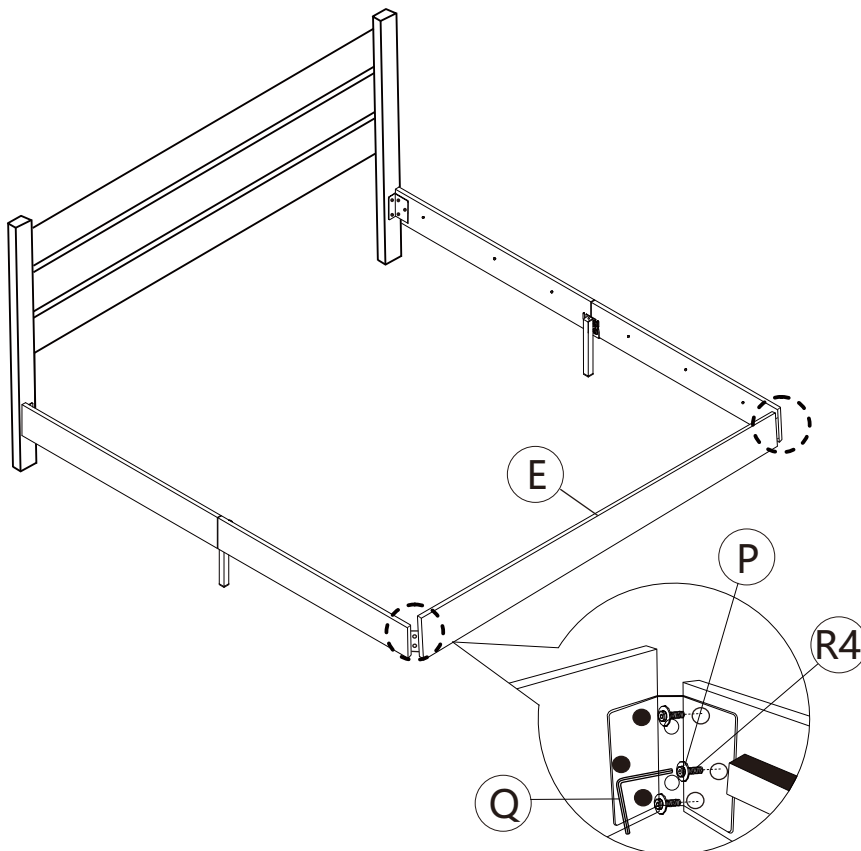

8



R4		6pcs
M8x16 mm		
P		6pcs
φ8x18x1.5 mm		
Q		1pc
M6		

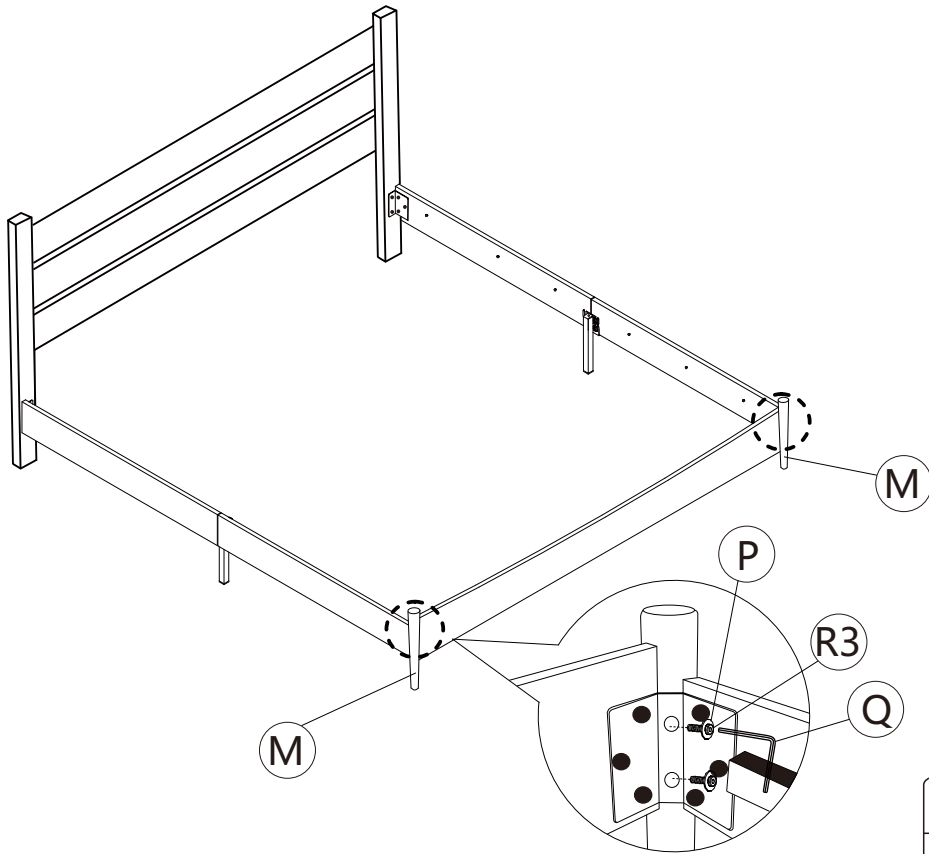

9

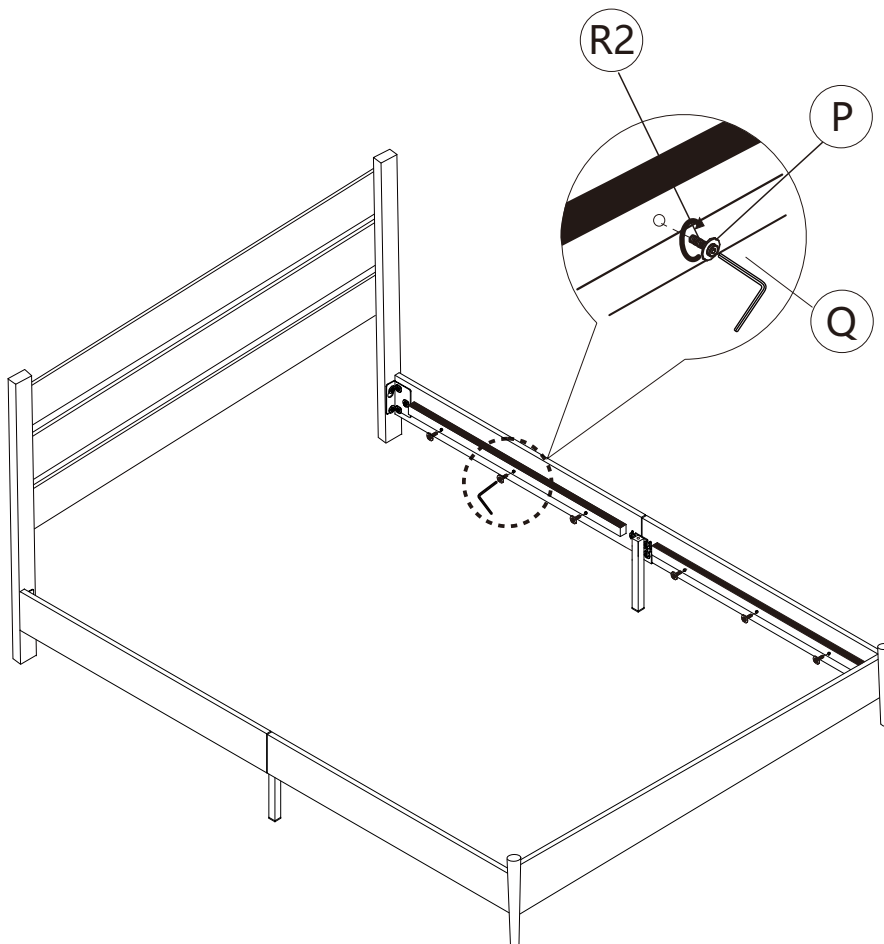

R3		4pcs
M8x25 mm		
P		4pcs
φ8x18x1.5 mm		
Q		1pc
M6		

10





R2		12pcs
M8x30 mm		
P		12pcs
φ8x18x1.5 mm		
Q		1pc
M6		

ASSEMBLY INSTRUCTIONS

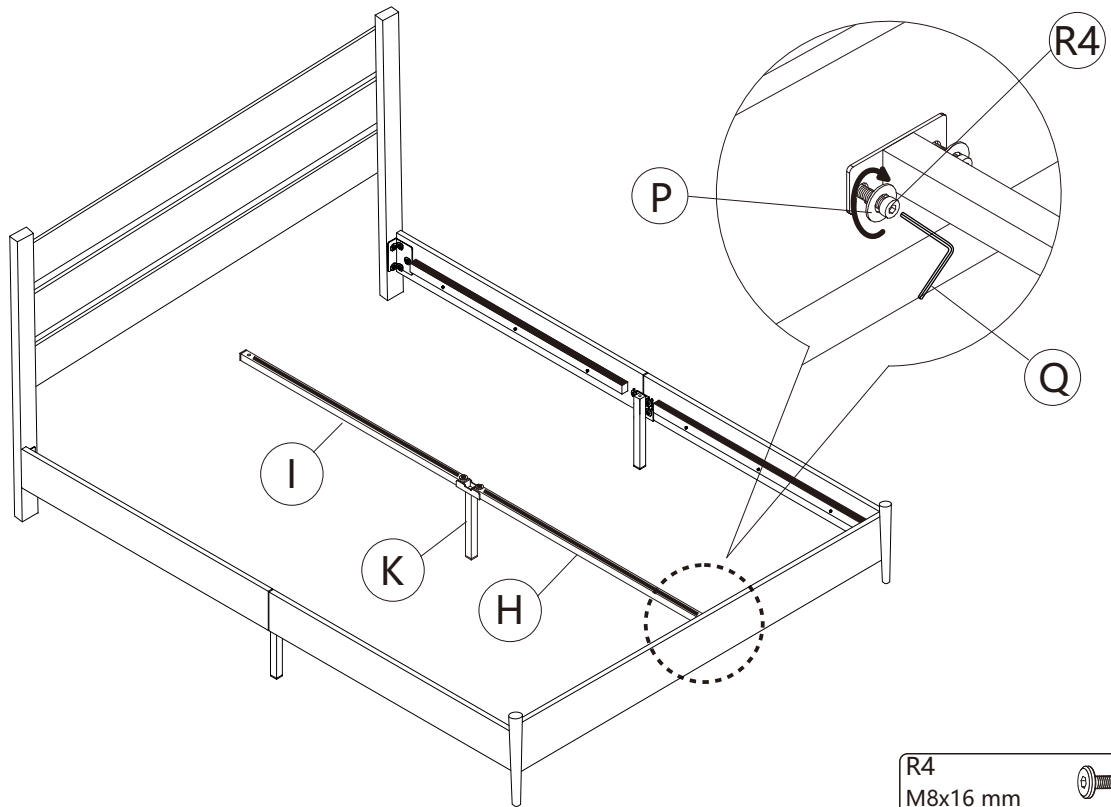

11

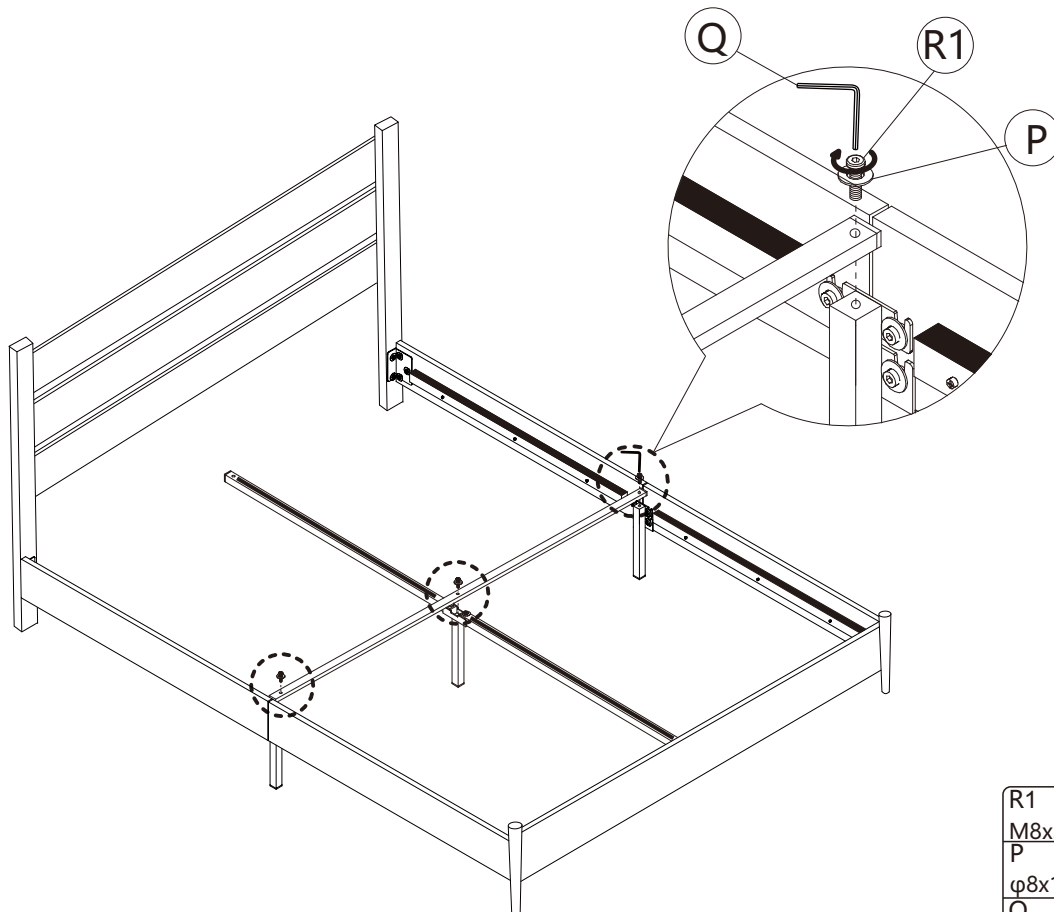

R4		2 pcs
M8x16 mm		
P		2 pcs
φ8x18x1.5 mm		
Q		1 pc
M6		

12



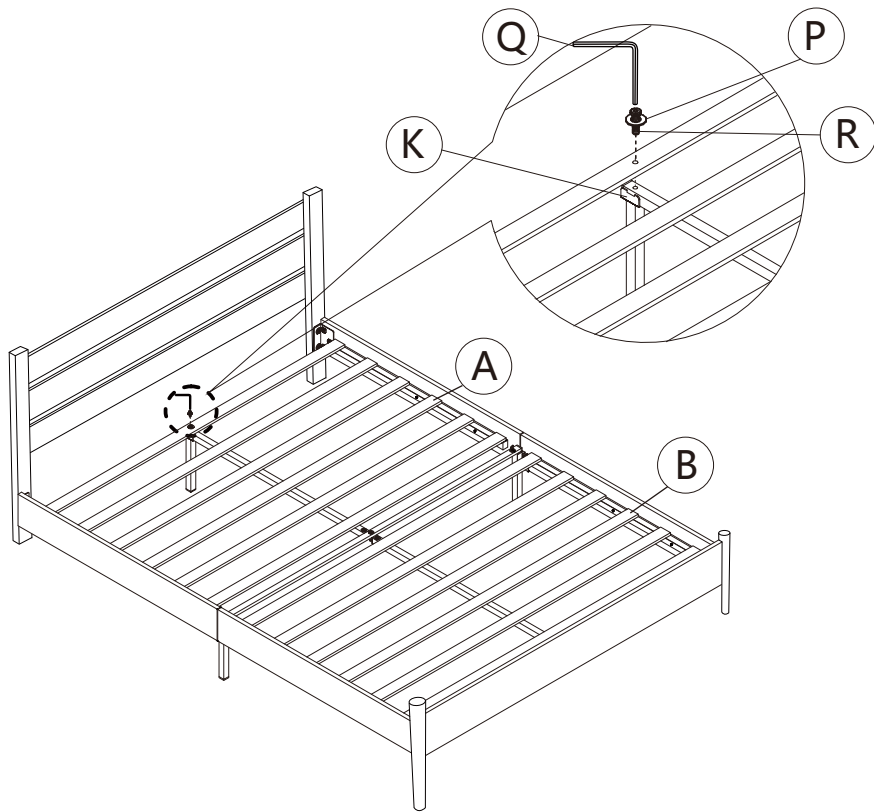

R1		3 pcs
M8x35 mm		
P		3 pcs
φ8x18x1.5 mm		
Q		1 pc
M6		

13 Note that there is a slat with a hole in part A for connecting to part K.



Pls make sure that all screws are 100% tight.

R		1pc
M8x50 mm		
P		1pc
φ8x18x1.5 mm		
Q		1pc
M6		

14 Stick **O** on the back to avoid noise.

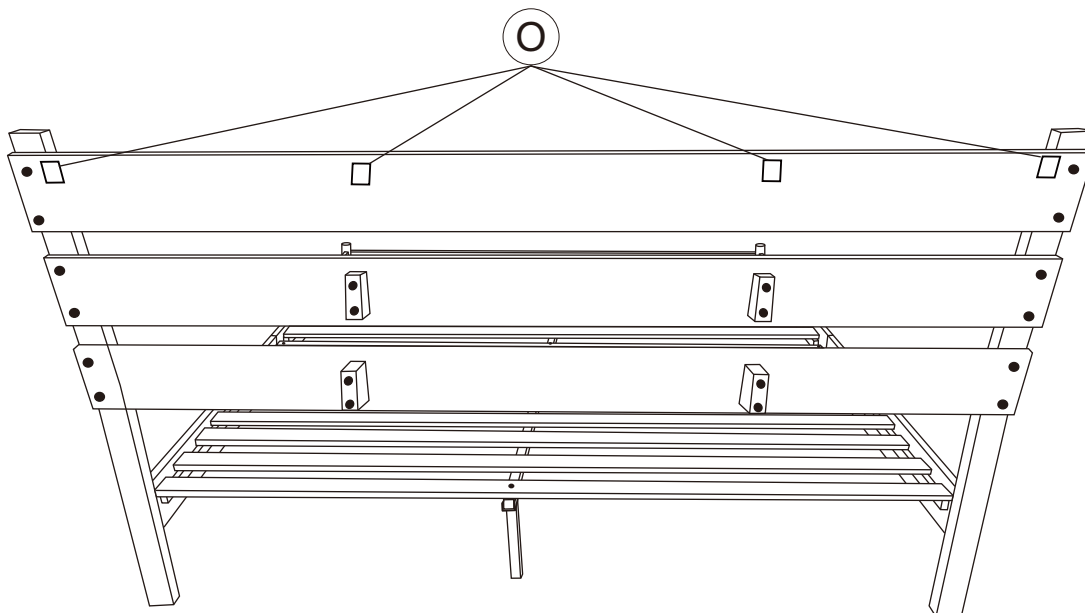

13

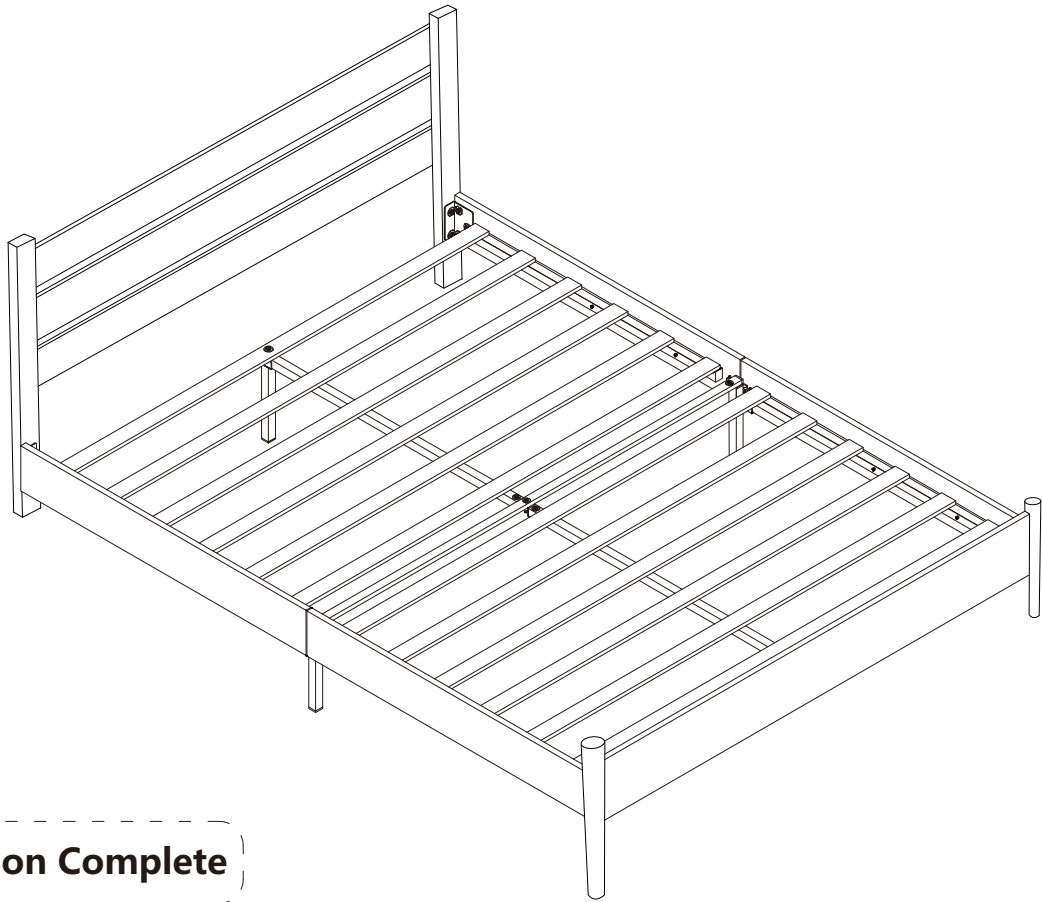

Installation Complete