

**Affordable Dreams
Start Here!**



**Hybrid Mattress
Product Information**

www.eneodirect.com

Thank you for your purchase, and welcome to the beginning of countless nights of great sleep!

Here are the guidelines for unboxing your new mattress:

- ✦ Please remove from all packaging within 3 days of receipt to allow it to reach its full size and comfort
- ✦ After removing all packaging, kindly allow 72 hours for your mattress to fully expand on a flat surface.
- ✦ Your brand new mattress may have a slight odor, which is normal for newly manufactured mattresses. The odor is not hazardous and will completely dissipate over time. For the best experience, we suggest letting your mattress air out in a well-ventilated space for 72 hours.
- ✦ The mattress is in compressed packaging and may expand immediately once opened. Please make sure to secure enough space before unwrapping, and keep small pets or children away while the mattress expands.

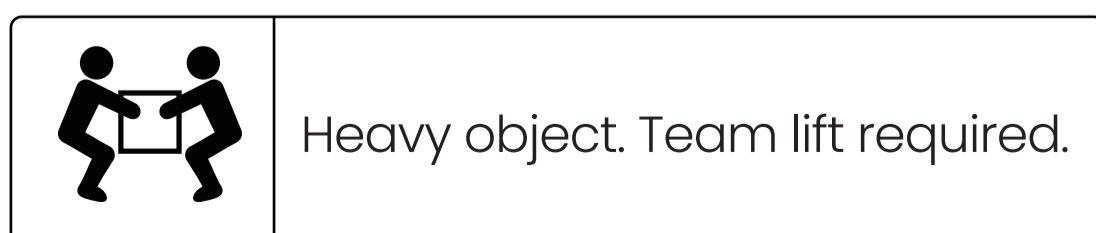

Step 1

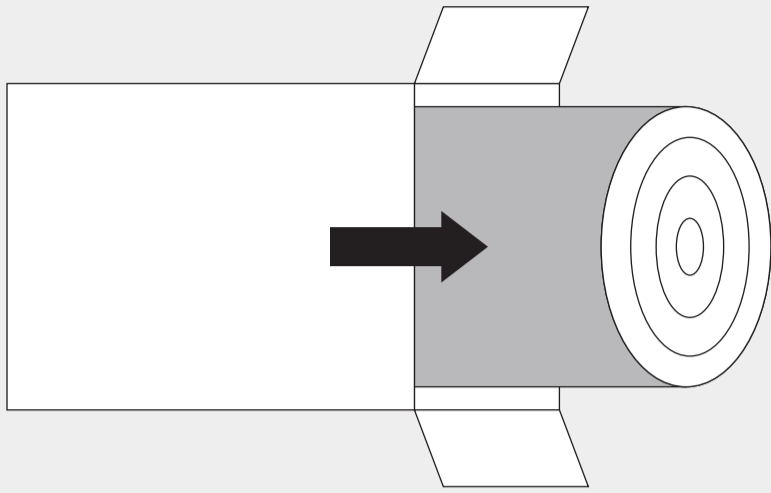

Remove the mattress from the box on its side on a flat, clean surface.

Step 2

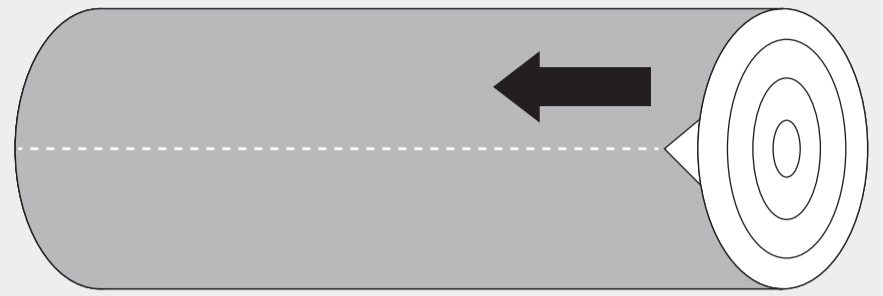

Tear open the outer plastic layer. **Do not use a knife** as it can damage the mattress.

Step 3

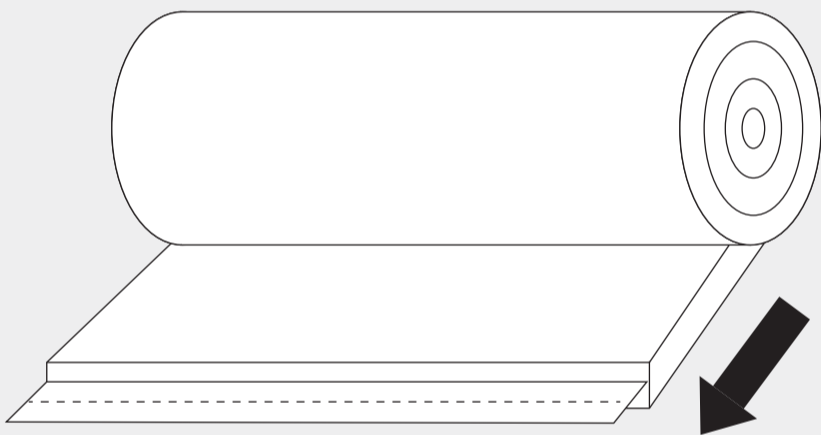

Roll out the compressed mattress, **zipper side down**.

Step 4

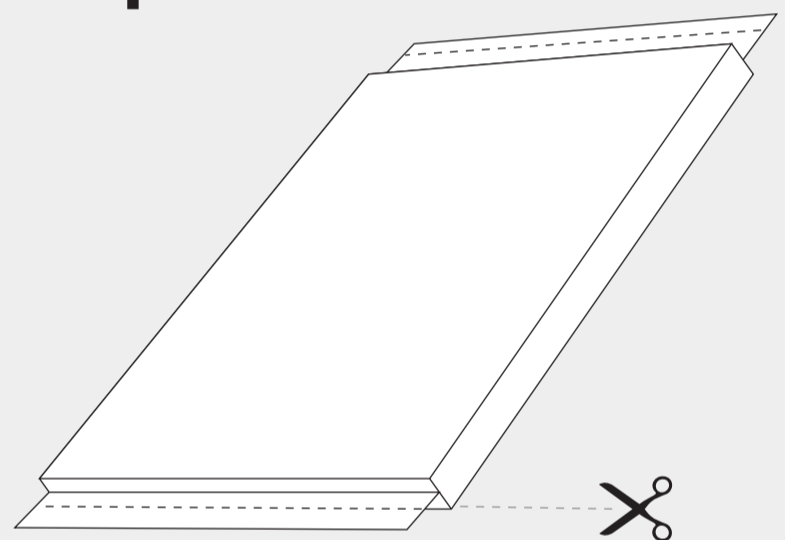

Carefully cut the **plastic bag** along the edges. The mattress will begin to decompress.

Step 5

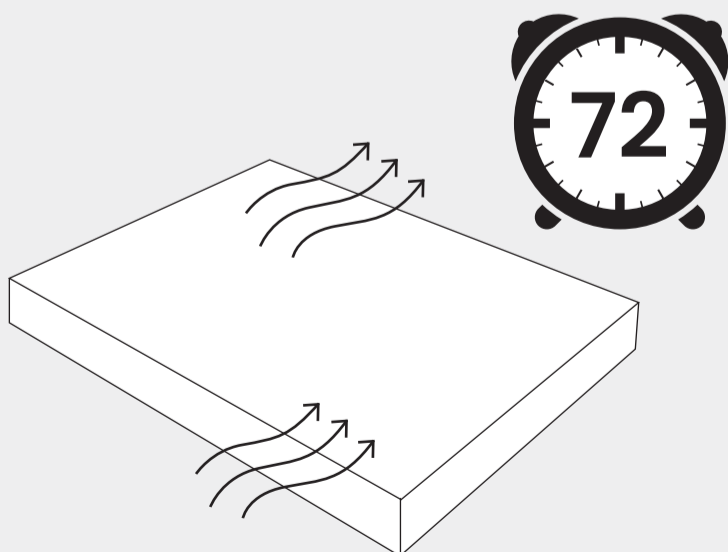

Let the mattress expand for 72 hours on a flat surface in a well-ventilated area.

If you have any questions about your new mattress, please contact our customer service team at **support@eneodirect.com**

We are happy to help if you run into any issues or have any questions about the product.

You can find the up-to-date warranty information at **www.eneodirect.com/pages/warranty**

Frequently Asked Questions

Q Does the mattress contain fiber glass?

A No, this mattress is fiberglass free.

Q Is the mattress waterproof?

A The mattress is not waterproof. To protect your mattress from water or stains, it is recommended to use an additional protective cover.

Q Is there an adjustment period for my new mattress?

A Yes, using a new mattress can require some time for your body to get used to. We recommend allowing yourself a minimum of 15 days to become accustomed to it.

Q What base can I use the mattress with?

A You can use this mattress with any type of foundation designed for beds, including: platform beds, bed frames, and adjustable bases.

Q What should I do if I have any issues with my mattress?

A Should you experience any issues or have any questions, please reach out to our customer support team for further assistance:
support@eneodirect.com