





Non-Swivel Vanity Stool

Examine all packaging material for small parts that may have come loose during shipment. Periodic checks are recommended to insure that all components are in proper position, tight and free from damage. Keep this assembly instruction for future reference. Adult assembly is require

CODE	QTY	HARDWARE	
1	8	Ø1/4"x35mm Allen Bolts	
2	8	Ø1/4" Spring Washers	
3	8	Ø1/4"x16x1.5mm Flat Washers	
4	1	4mm Allen Wrench	
5	4	Bolt Cover	

CODE	QTY	COMPONENTS	CODE	QTY	COMPONENTS
A	1	Cushion	B	1	Crossbar Frame
					
			C	2	Leg Frames
					

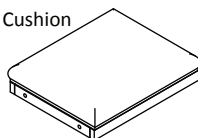
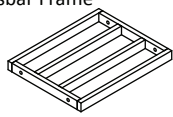
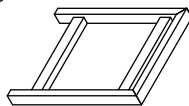
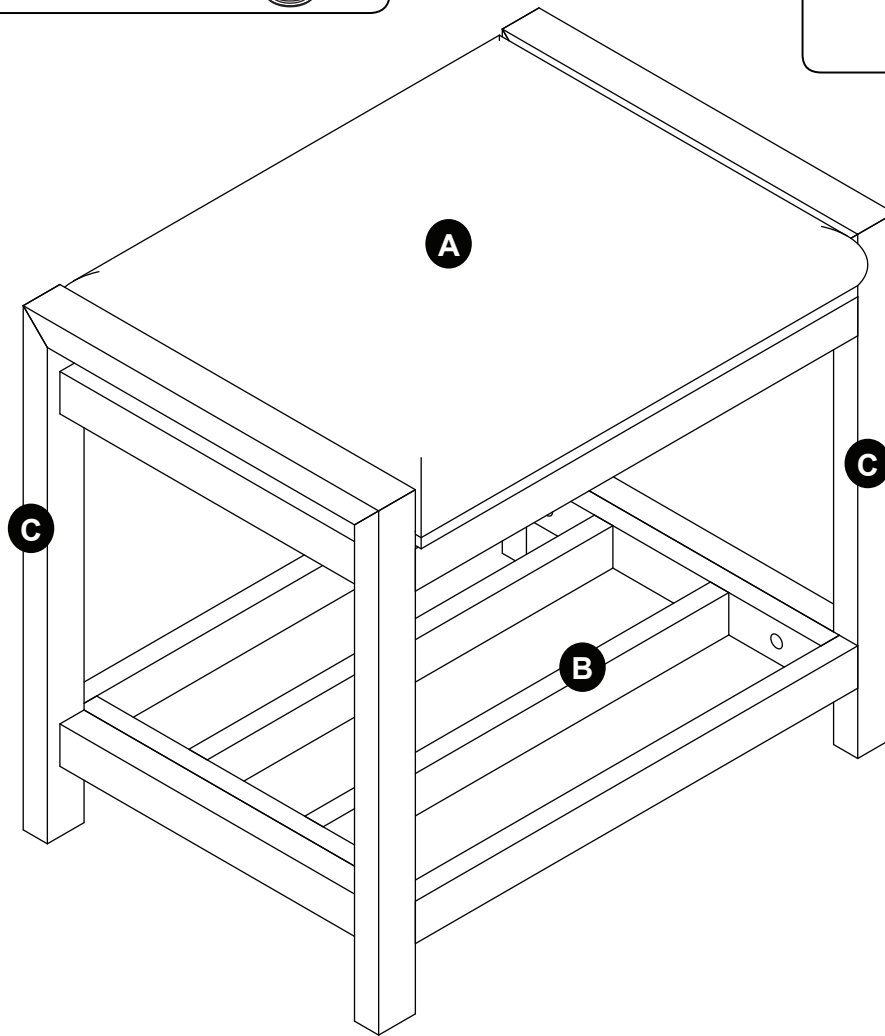

WARNING

- Do not let any sharp objects touch or rub the surface of the product.
- When assembling, do not let children play around the working area.
- Please confirm all parts are correct before starting the assembly process.
- Do not tighten all bolts and screws completely until the entire unit has been assembled and set up.
- Be careful if using power tools as they can over tighten screws and strip threads.

CARE & MAINTENANCE: The touch of a soft cloth is all the maintenance the finish will ever need. Please do not use harsh or abrasive cleaners for polishing, as they may cause damage to the finish. Periodic checks are recommended to make sure that all hardware is securely tightened.

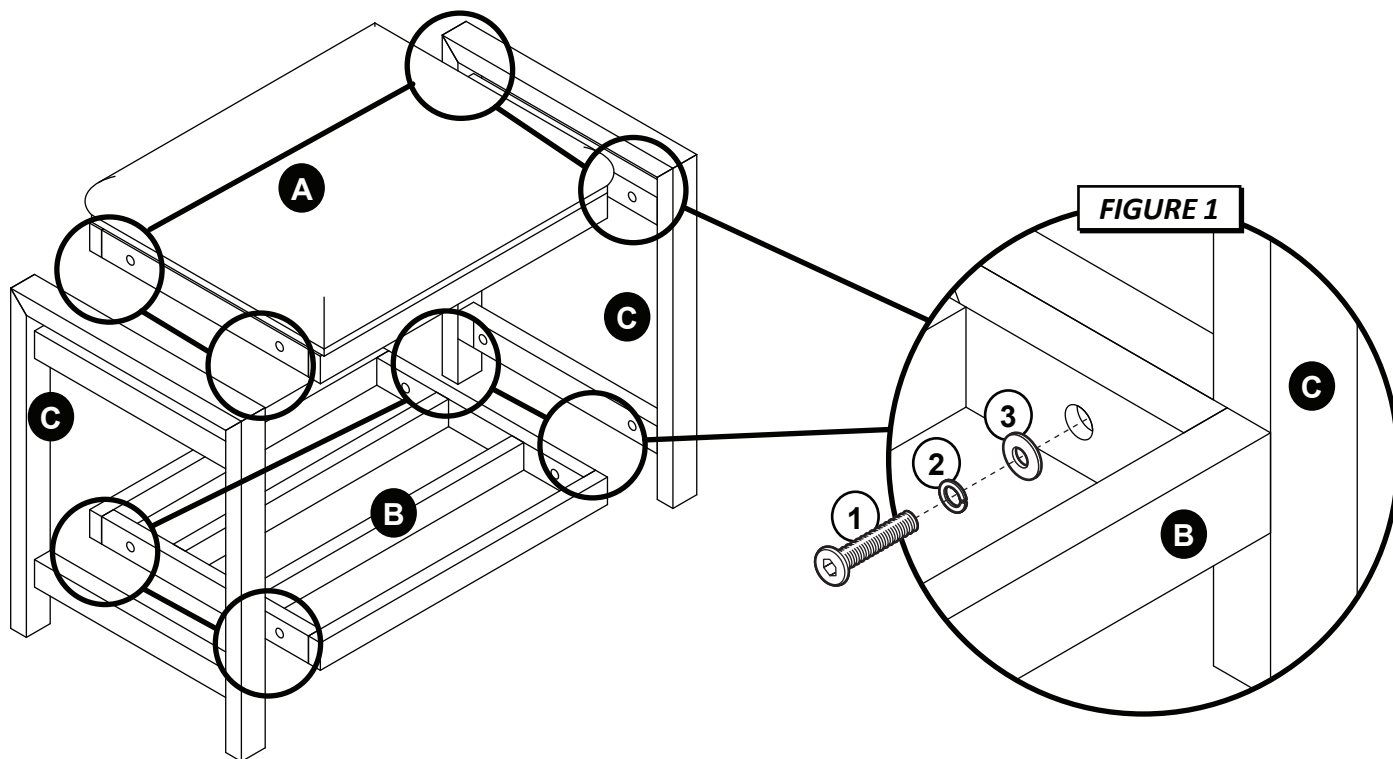

STEP 1 - Figure 1

Begin assembly by attaching Leg Frames (C) to Cushion (A) and Crossbar Frame (B) by using Allen Bolts (1), Spring Washers (2) and Flat Washers (3). Tighten bolts using Allen Wrench (4) provided.

STEP 2 - Figure 2

Cover spaces over bolts on Crossbar Frame (B) with Bolt Covers (5). The assembly is now complete.

