

Assembly Instructions

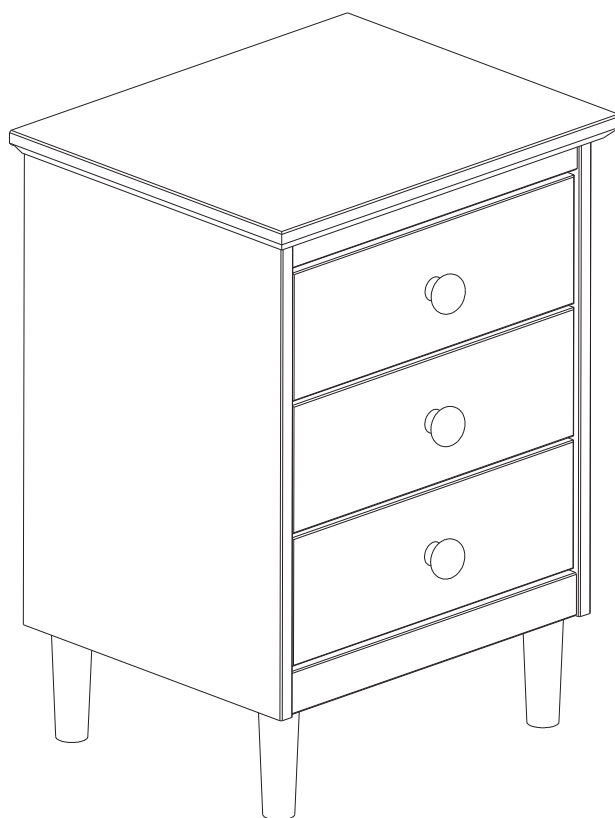

General Assembly Guidelines

- I. Ensure that all parts and hardware are available before beginning assembly.
- II. Follow each step carefully to ensure the proper assembly of this product.
- III. Two people are recommended for ease in the assembly of this product.
- IV. The three main types of hardware used to assemble this product are wood dowels, screws and bolts.
- V. The provided glue is to secure wood dowels in place . When first inserting dowels , locate the appropriate hole for the dowel , place a small amount of glue in the hole and insert the dowel . Wipe away excess glue immediately.

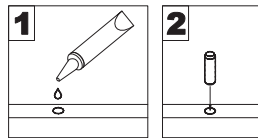

In future assembly steps when dowels are necessary to attach assembly parts together , place a small amount of glue on the end of the dowel before attaching parts together . Wipe away excess glue immediately.

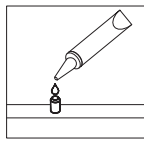

- VI. A Phillips head screwdriver is required for the assembly of this product.

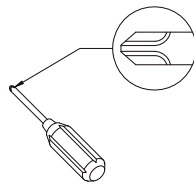

- VII. Power tools should not be used to assemble this product.

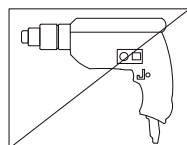



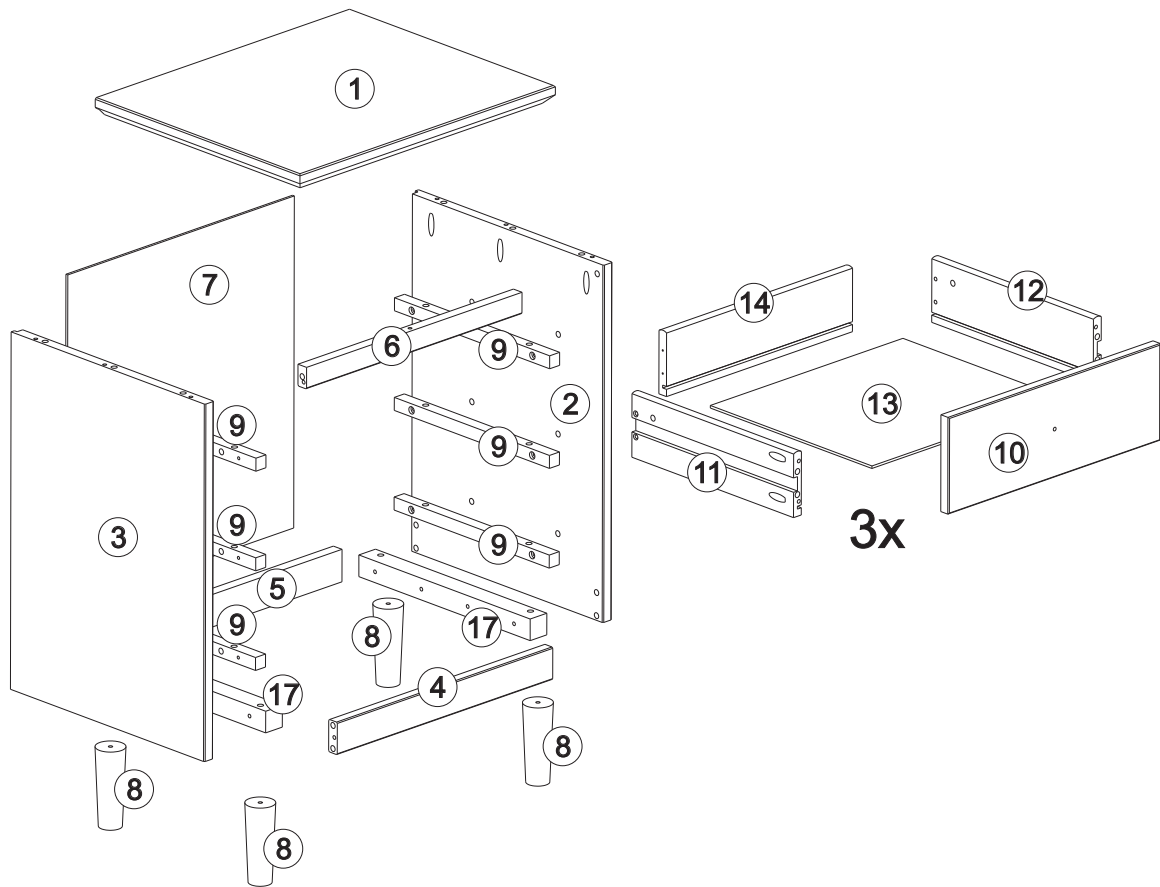





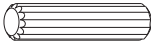

Parts List

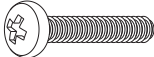

Part#	Description	Qty
1	Top panel	01 pcs
2	Right side panel	01 pcs
3	Left side panel	01 pcs
4	Bottom front crossbeam	01 pcs
5	Back crossbeam	01 pcs
6	Upper front crossbeam	01 pcs
7	Back panel	01 pcs
8	Foot	04 pcs

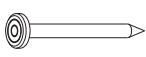
Part#	Description	Qty
9	Drawer runner	06 pcs
10	Front drawer	03 pcs
11	Left side drawer	03 pcs
12	Right side drawer	03 pcs
13	Drawer bottom	03 pcs
14	Drawer back	03 pcs
17	Foot crossbeam	02 pcs

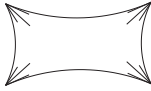
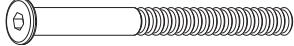
Hardware List

A		Ø8*30mm	Wooden dowel	40 pcs
B		Ø8*20mm	Wooden dowel	12 pcs
C		Ø3,5*25mm	Screw	12 pcs
D		Ø3,5*30mm	Screw	37 pcs
E		M4*22mm	Screw	03 pcs
F		Ø4,5*45mm	Screw	08 pcs
G		Ø10*10	Nail	16 pcs
H			Knob	03 pcs
I			Glue	01 pcs
J		Ø7*80mm	Screw	04 pcs
K			Allen key	01 pcs

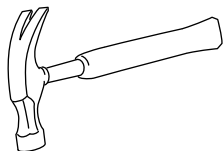

Hammer recommended for assembly
(not included)

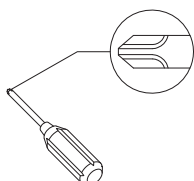



Philips head screwdriver required for assembly
(not included)

*The hardware quantities listed above are required for proper assembly.
Some extra hardware may also have been included.*

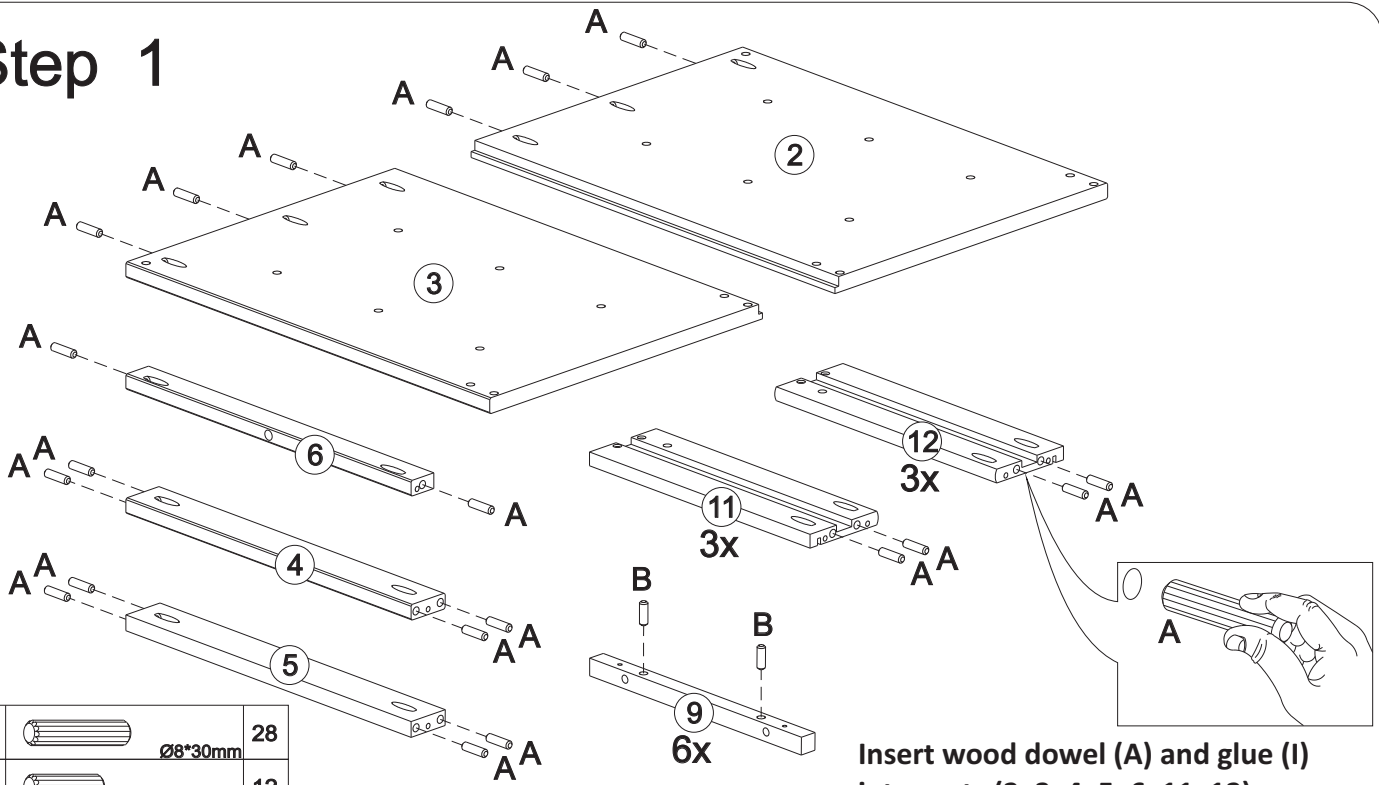
Step 1



A		28
B		12
I		01

Insert wood dowel (A) and glue (I) into parts (2, 3, 4, 5, 6, 11, 12).
Insert wood dowel (B) and glue (I) into part (9).

Step 2

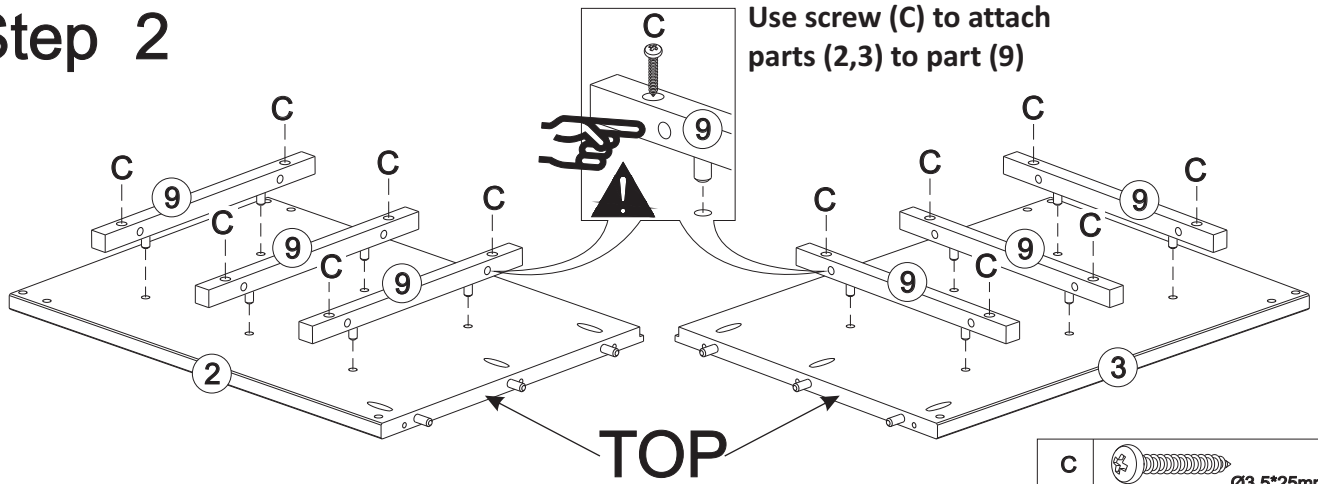

Use screw (C) to attach parts (2,3) to part (9)

c		12
---	---	----

Step 3

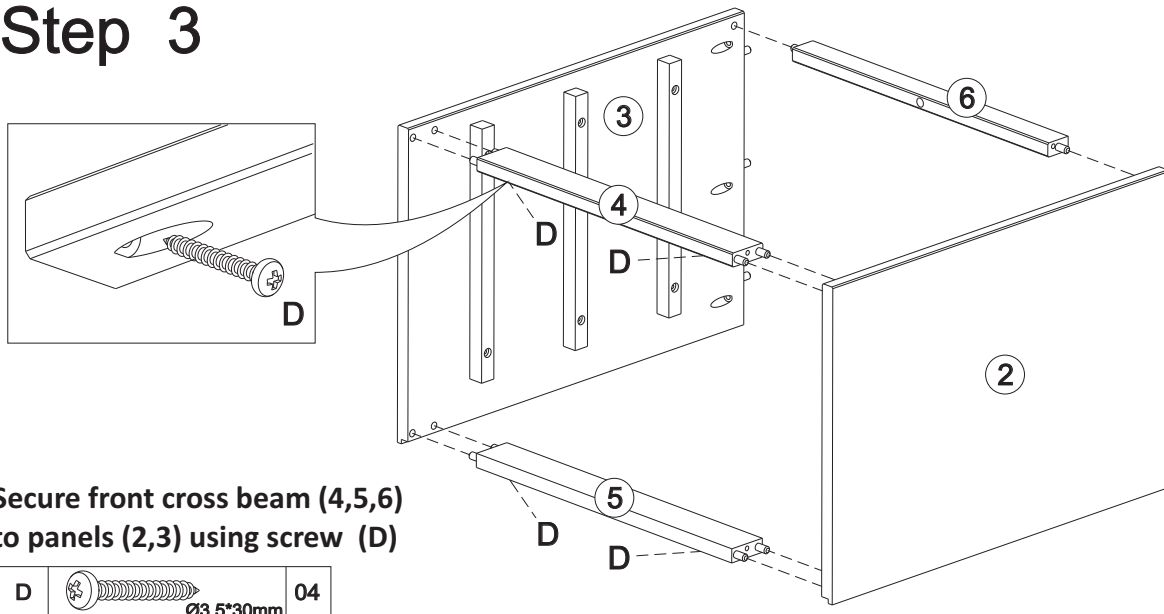

Secure front cross beam (4,5,6) to panels (2,3) using screw (D)

D		04
---	---	----

Step 4

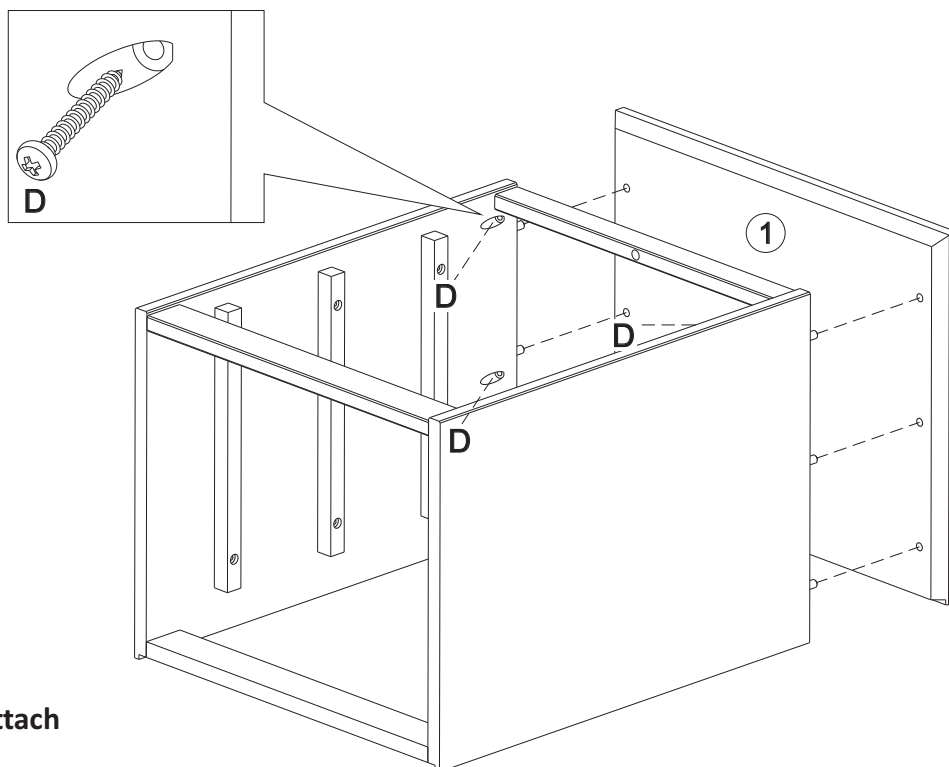

Use screw (D) to attach
part (1) to body

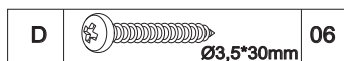

Step 5

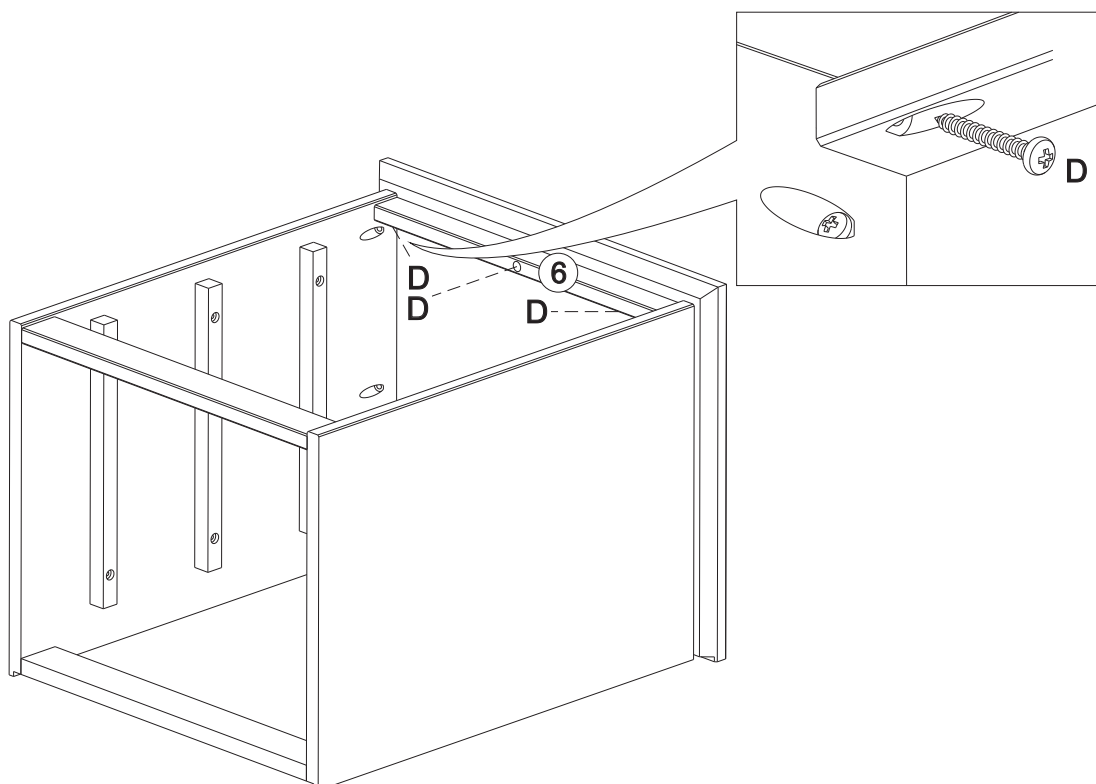

Use screw (D) to attach
part (6) to body

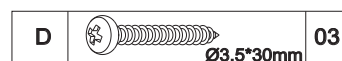

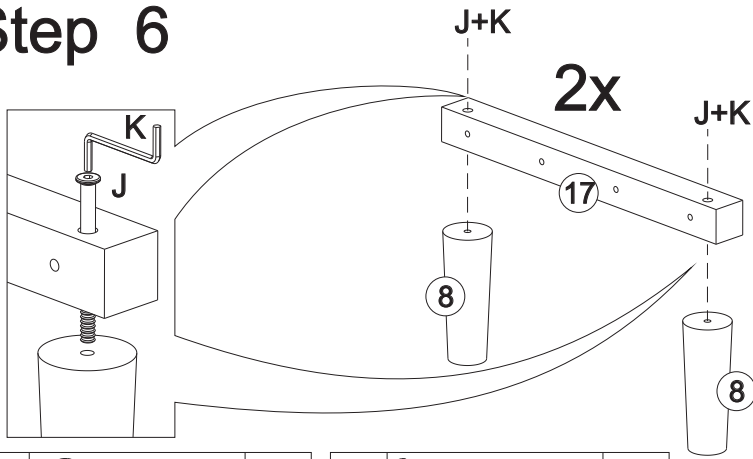

Step 6

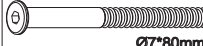

Apply glue to leg contact surfaces

Use screw (J) to attach part (15) to part (8) and key (K).
Attach parts (8) with screws (F) and glue (I).

F		08	J		04
I		01	K		01
		Glue tube			Allen key

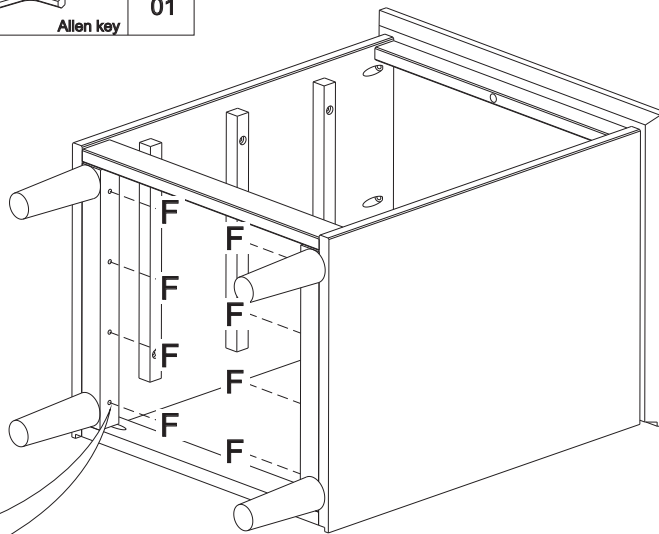
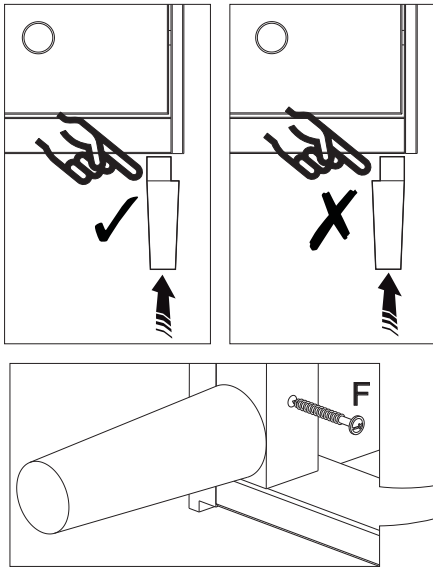

Step 7

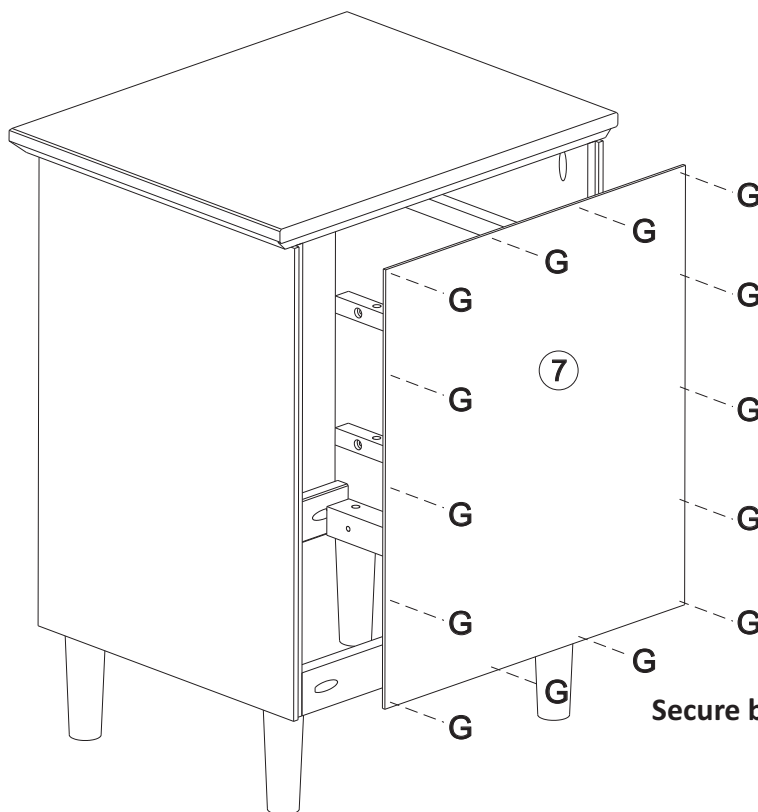

Secure back panel (7) with part (G).

G		16
		Ø10*10

Step 8

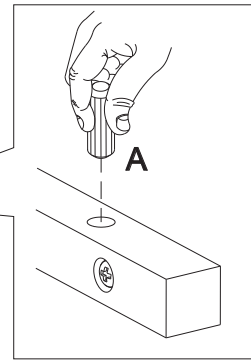
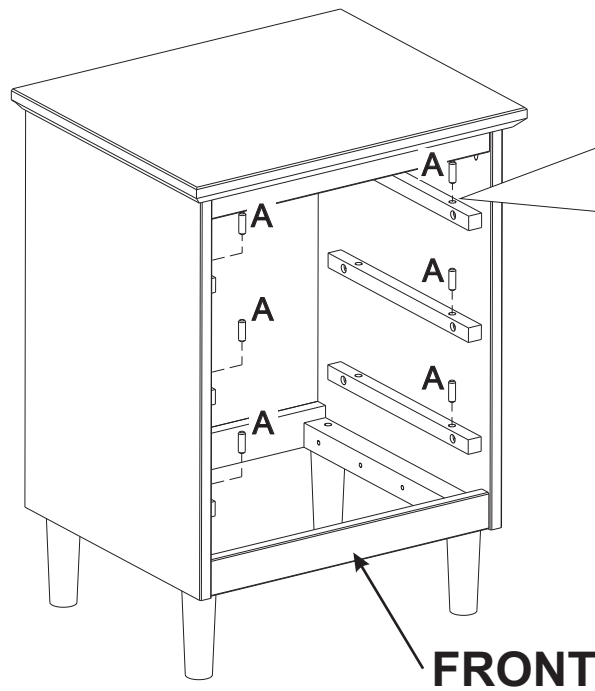

Insert wood dowel (A) into part (9) (Runner small).

A		06 Ø8*30mm
---	--	---------------

Step 9

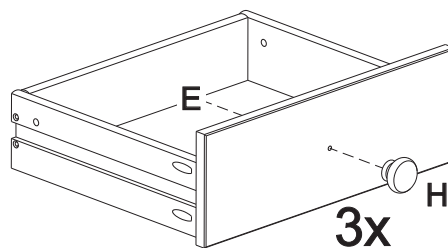
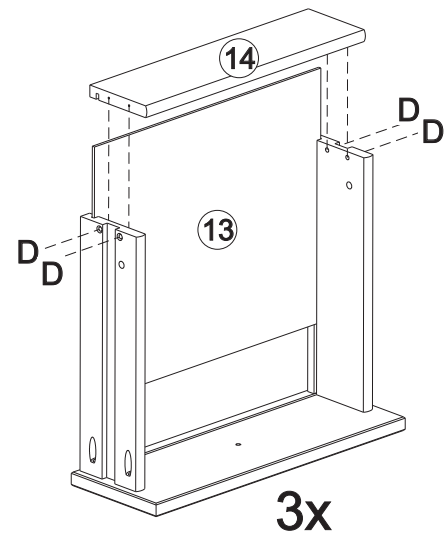
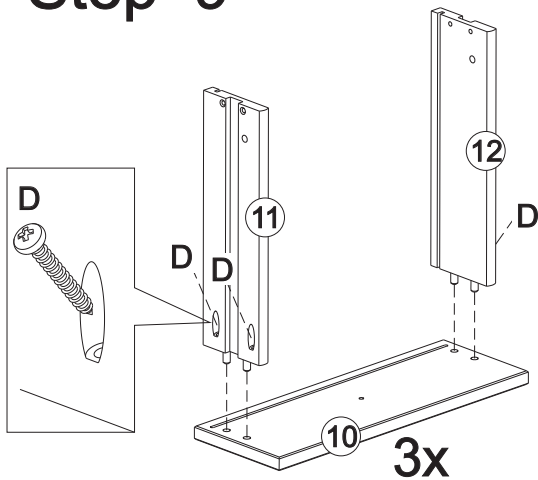

Attach parts (11,12) to part (10), insert panel (13) into grooves and secure part (14) with screws(D) Insert knob (H) with screws(E).

D		24 Ø3,5*30mm
E		03 M4x22mm
H		03

Step 10

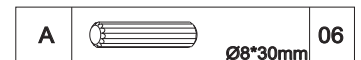
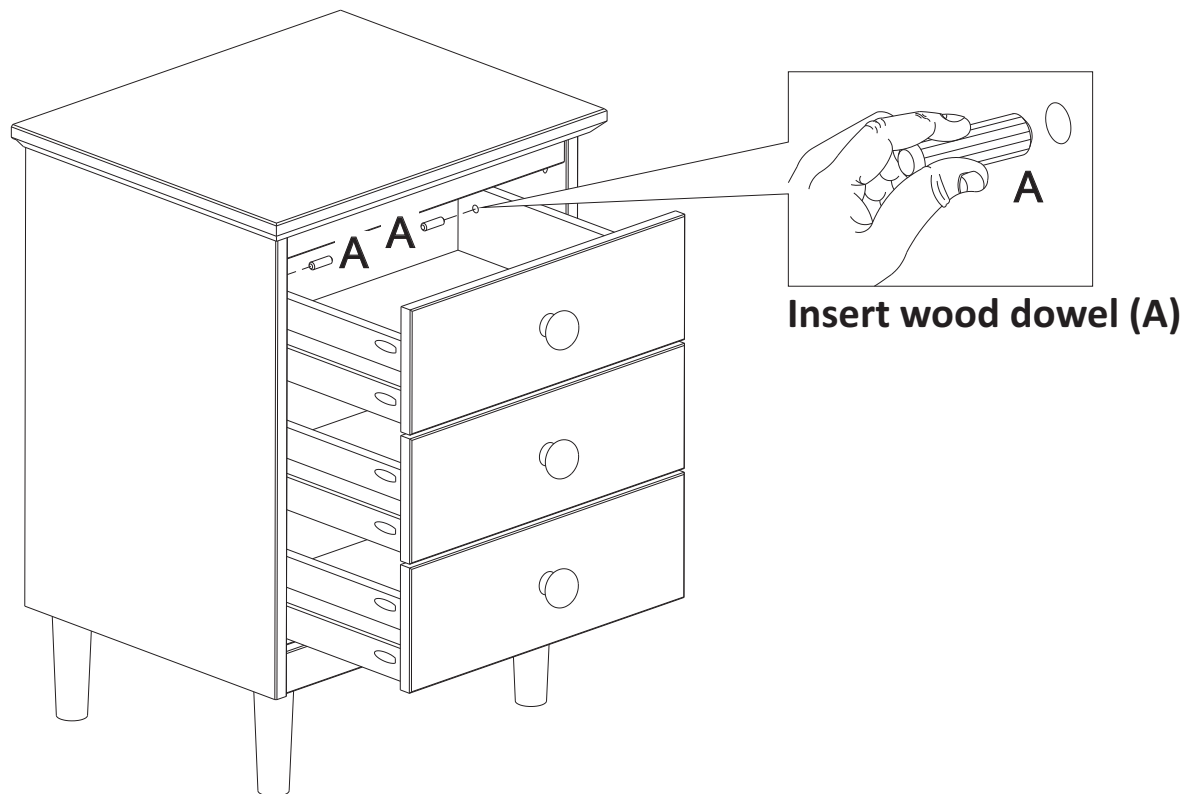

Assembly Complete!

Maintenance Guide

To maintain long term performance and easy gliding of your solid wood drawers, we recommend applying wax to the wooden guide rails.

1. Bee's wax is recommended or Paraffin wax from a standard candle can be used.
2. Apply the wax by rubbing it on the wooden guide rails where there is wood-on-wood contact when opening and closing the drawer. (Wax should be room temperature, do not melt the wax onto the wood)
3. Wax should be applied every few months for the first year and then only when needed after that to keep the drawers sliding smoothly.