

Lifting coffee table

Assembly Instructions - Please keep for future reference

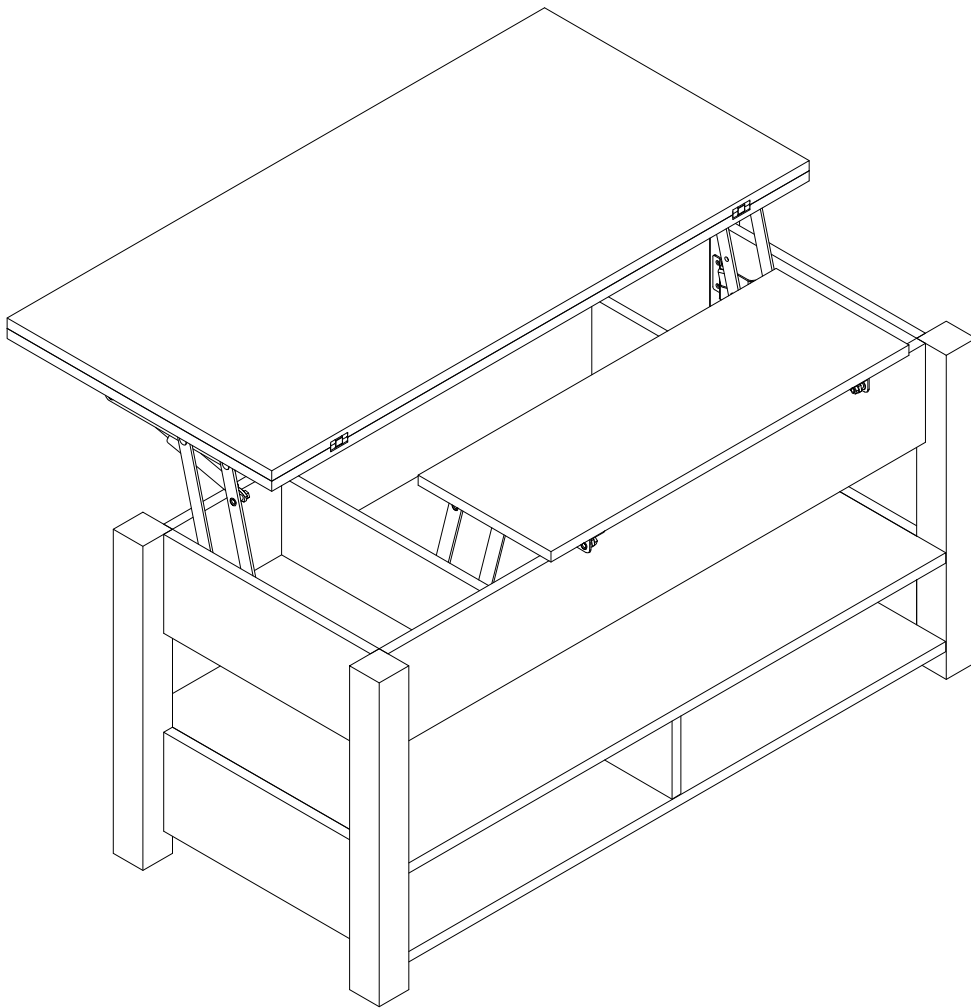

Dimensions

Width-41.7inch

Depth-19.7inch

Height-20inch

Important-Please read these instructions fully before starting assembly



Safety and Care Advice

Important – Please read these instructions fully before starting assembly

- Check you have all the components and tools listed on the following pages.
- Remove all fittings from the plastic bags and separate them into their groups.
- Keep children and animals away from the work area, small parts could choke if swallowed.
- Make sure you have enough space to layout the parts before starting.

- During assembly do not stand or put weight on the product, this could cause damage.
- Assemble the item as close to its final position (in the same room) as possible.
- Assemble on a soft level surface to avoid damaging the unit or your floor.
- Parts of the assembly will be easier with 2 people.



power drill is set on a low torque setting.

- To reduce the likelihood of damaging your product please ensure that your

Care and maintenance

• Only clean using a damp cloth and mild detergent, do not use bleach or abrasive cleaners.

• From time to time check that there are no loose screws on this unit.

• This product should not be discarded with household waste. Take to your local authority waste disposal centre.

Handy Hints

• Assemble all parts and bolts loosely during assembly, only once the product is complete should you fully tighten the bolts

• Regularly check and ensure That all bolts and fittings are tightend properly.

WARNING
In order to help prevent overturning – please follow these instructions

To help prevent product toppling over please follow the below steps:-

- Use the anti tip stap or wall fixing method provided (if applicable)
- Do not allow children to climb or hang on the furniture
- Do not open more than one drawer at a time
- Do not place heavy items in the top drawers
- Do not place heavy items on top of the furniture, unless the furniture has been designed for this purpose

Components - Fittinas

Please check you have all the panels listed below

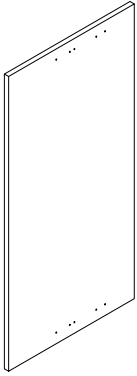
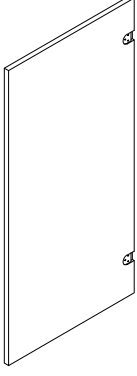
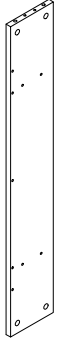
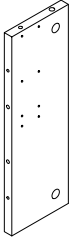
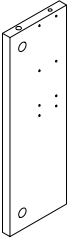
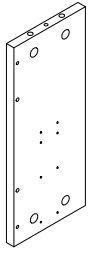
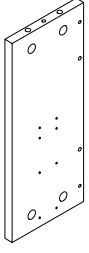
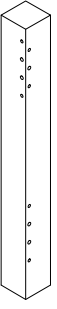
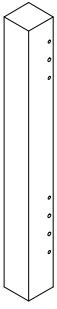
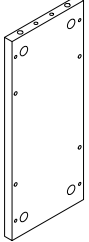
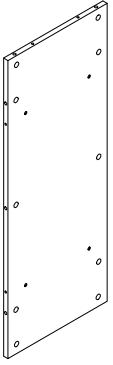
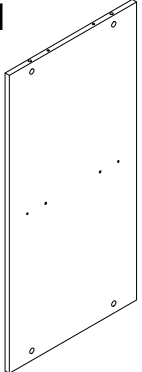
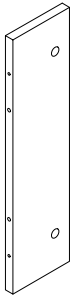
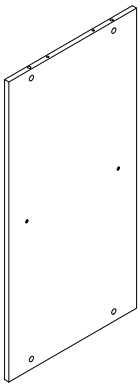
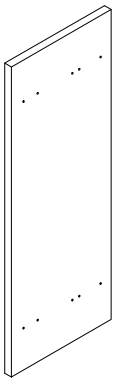
<p>① x1</p>  <p>1060x500x15mm</p>	<p>② x1</p>  <p>1060x500x15mm</p>	<p>③ x2</p>  <p>910x145x15mm</p>	<p>④ x1</p>  <p>350x115x15mm</p>
<p>⑤ x1</p>  <p>350x115x15mm</p>	<p>⑥ x1</p>  <p>350x145x15mm</p>	<p>⑦ x1</p>  <p>350x145x15mm</p>	<p>⑧ x2</p>  <p>475x50x50mm</p>
<p>⑨ x2</p>  <p>475x50x50mm</p>	<p>⑩ x2</p>  <p>350x145x15mm</p>	<p>⑪ x1</p>  <p>910x350x15mm</p>	<p>⑫ x1</p>  <p>910x448x15mm</p>
<p>⑬ x1</p>  <p>447x115x15mm</p>	<p>⑭ x1</p>  <p>910x448x15mm</p>	<p>⑮ x1</p>  <p>600x225x15mm</p>	

Components - Fittinas

Please check you have all the panels listed below

Note : The quantitie below are the correct amount to complete the assembly . In some cases more fittings may be supplied than are required.

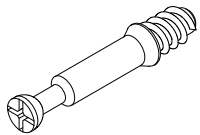
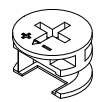
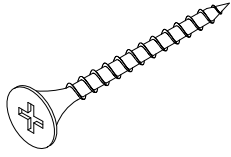
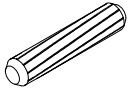
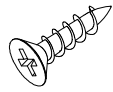
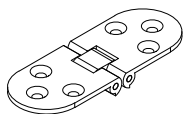
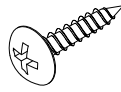
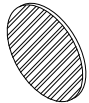
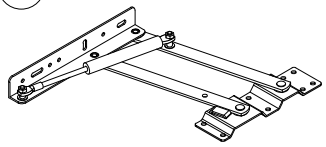
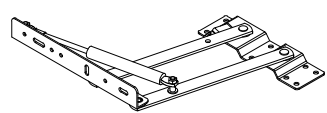
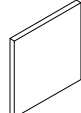
<p>A</p>  <p>Ø6*35mm Cam Bolt x 48</p>	<p>B</p>  <p>Ø15*9mm Cam lock x 48</p>	<p>C</p>  <p>4*40mm Screw x 6</p>	<p>D</p>  <p>6*30mm Dowel x 48</p>
<p>E</p>  <p>3.5*14mm Screw x 12</p>	<p>F</p>  <p>Hinge x 2</p>	<p>G</p>  <p>4*14mm Screw x 52</p>	<p>H</p>  <p>Ø20mm Cap Sticke x 30</p>
<p>I</p>  <p>Lifter x 2</p>	<p>J</p>  <p>Lifter x 2</p>	<p>K</p>  <p>30*30mm Non-Slip mat x 4</p>	

Tools required

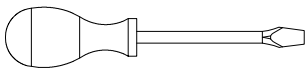

Phillips screwdriver
(medium large)

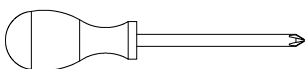

Using Camlocks

Step 1

Connect the male camlock as directed in the assembly instructions using a screwdriver.

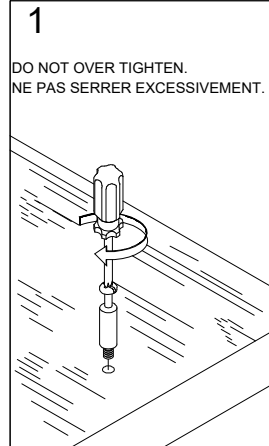

Step 2

Push the male camlock into the entry hole.

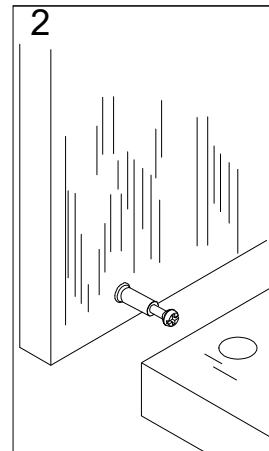

Step 3

Insert the female camlock as shown in the instruction.

Note: ensure that the arrow on the top of the camlock points towards the entry hole for the male camlock.

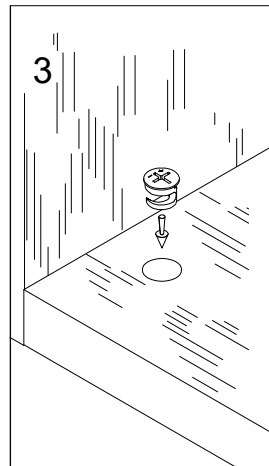

Step 4

Turn the female camlock clockwise with a screwdriver.

You should feel a click when the camlock is locked in place.

The joint is now secure.

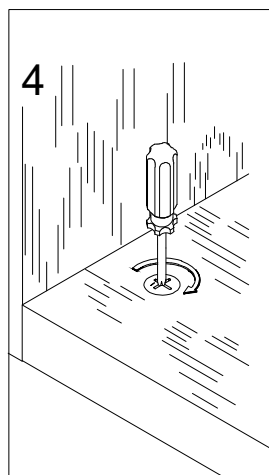

Assembly Instructions

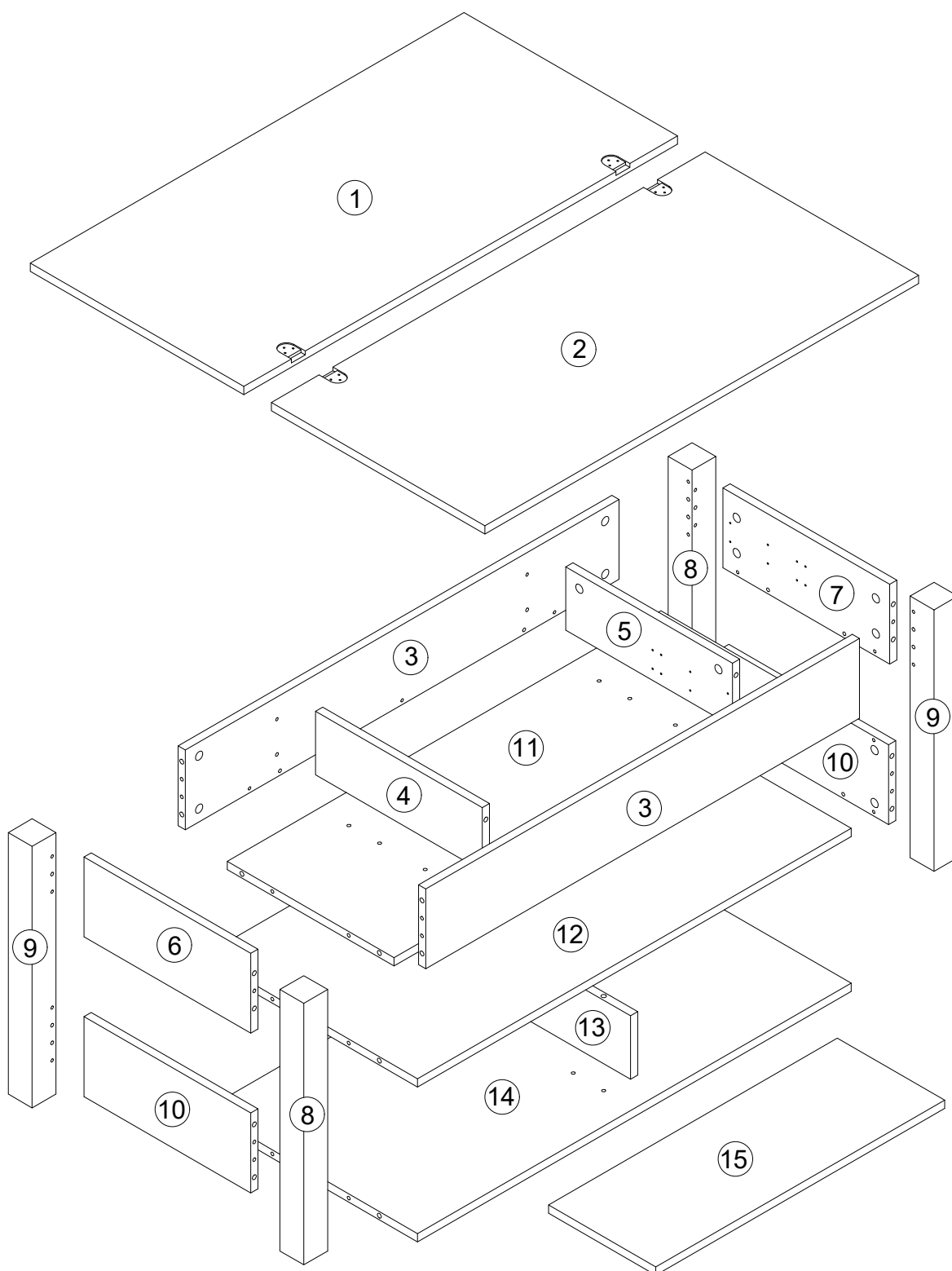

Assembly Instructions

step 1

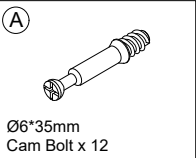
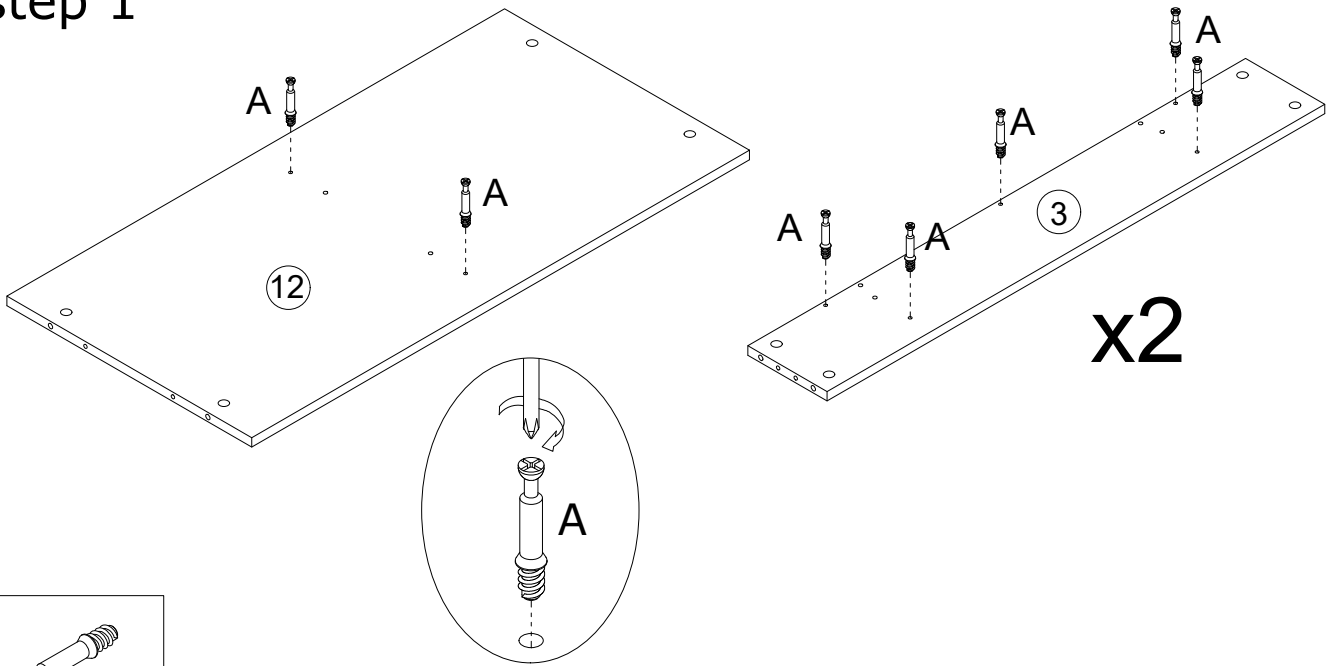

step 2

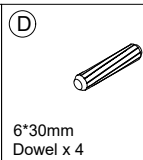
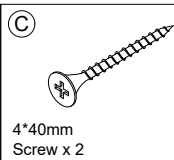
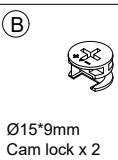
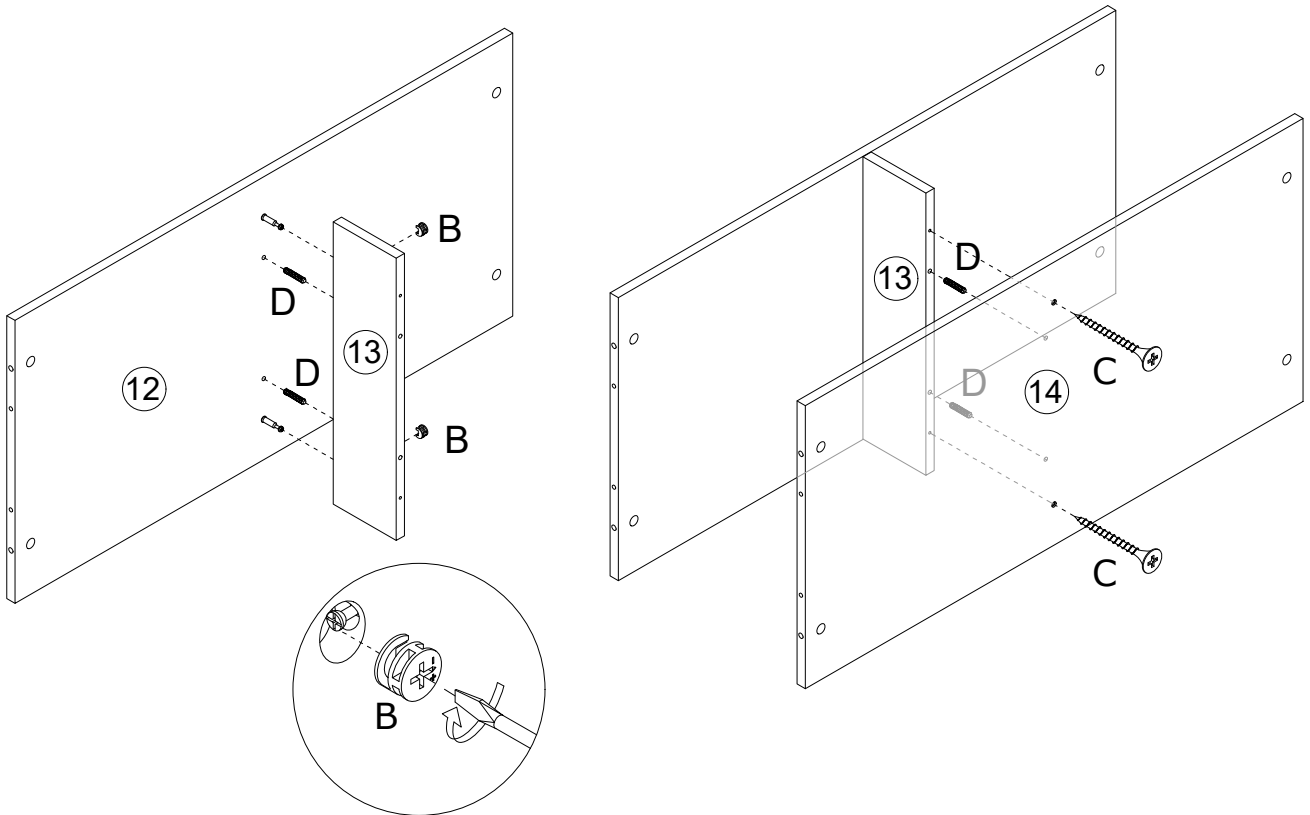

Assembly Instructions

step 3

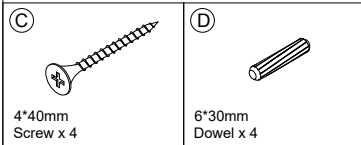
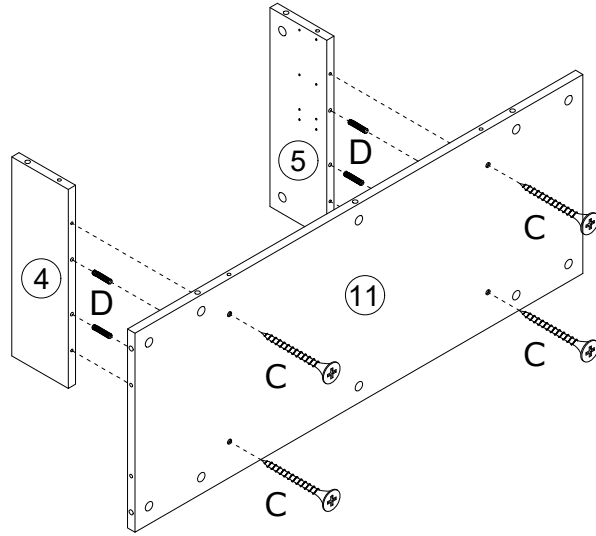

step 4

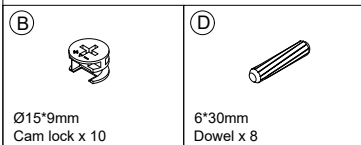
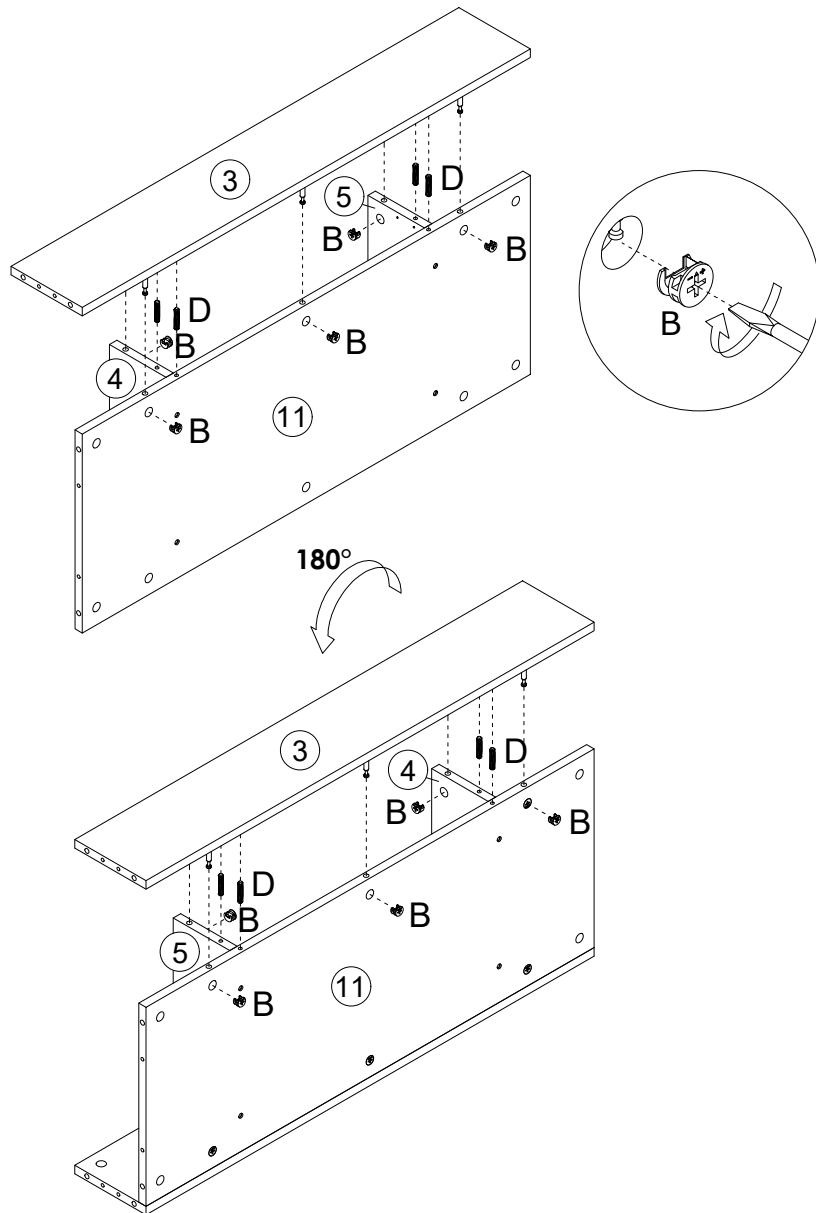

Assembly Instructions

step 5

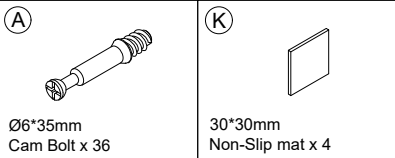
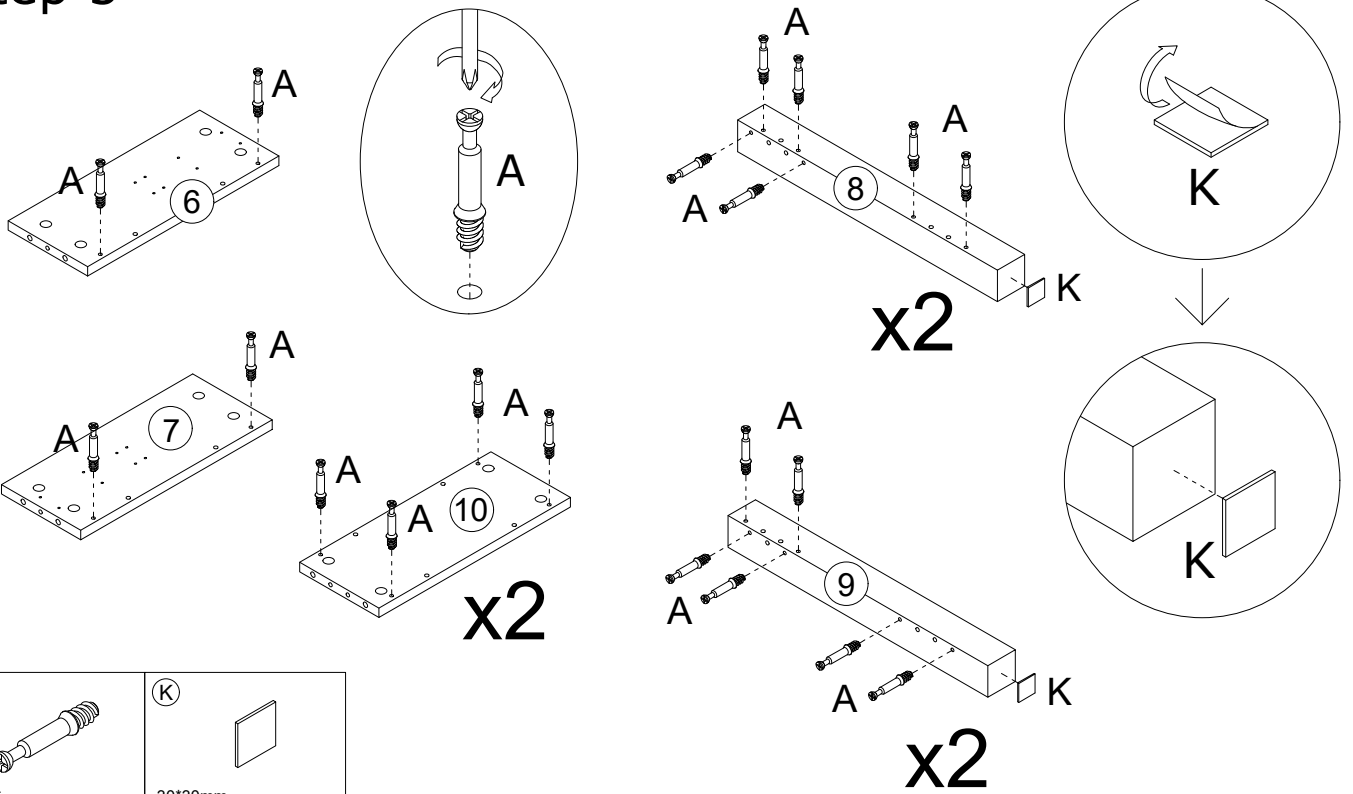

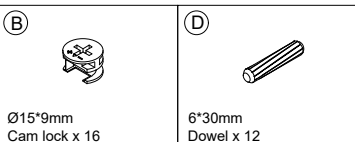
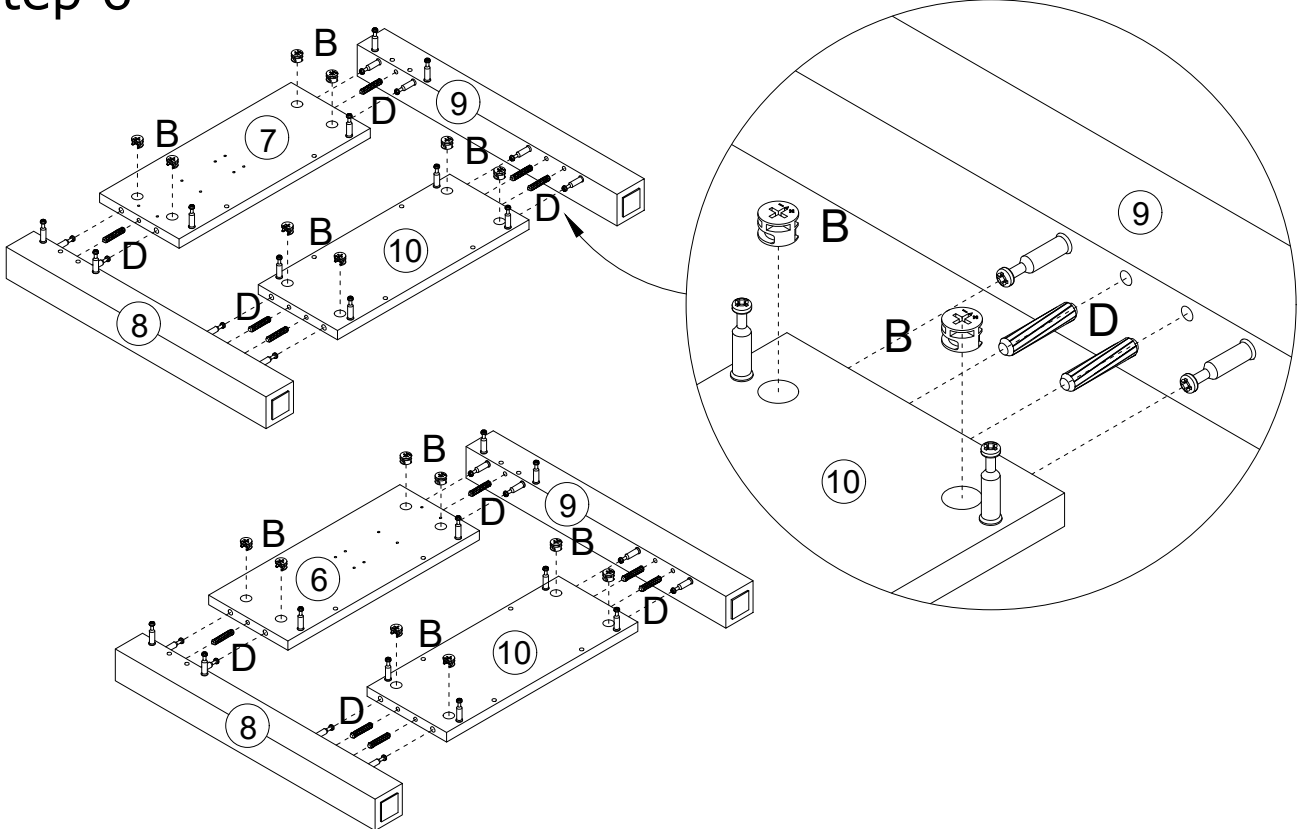

step 6



Assembly Instructions

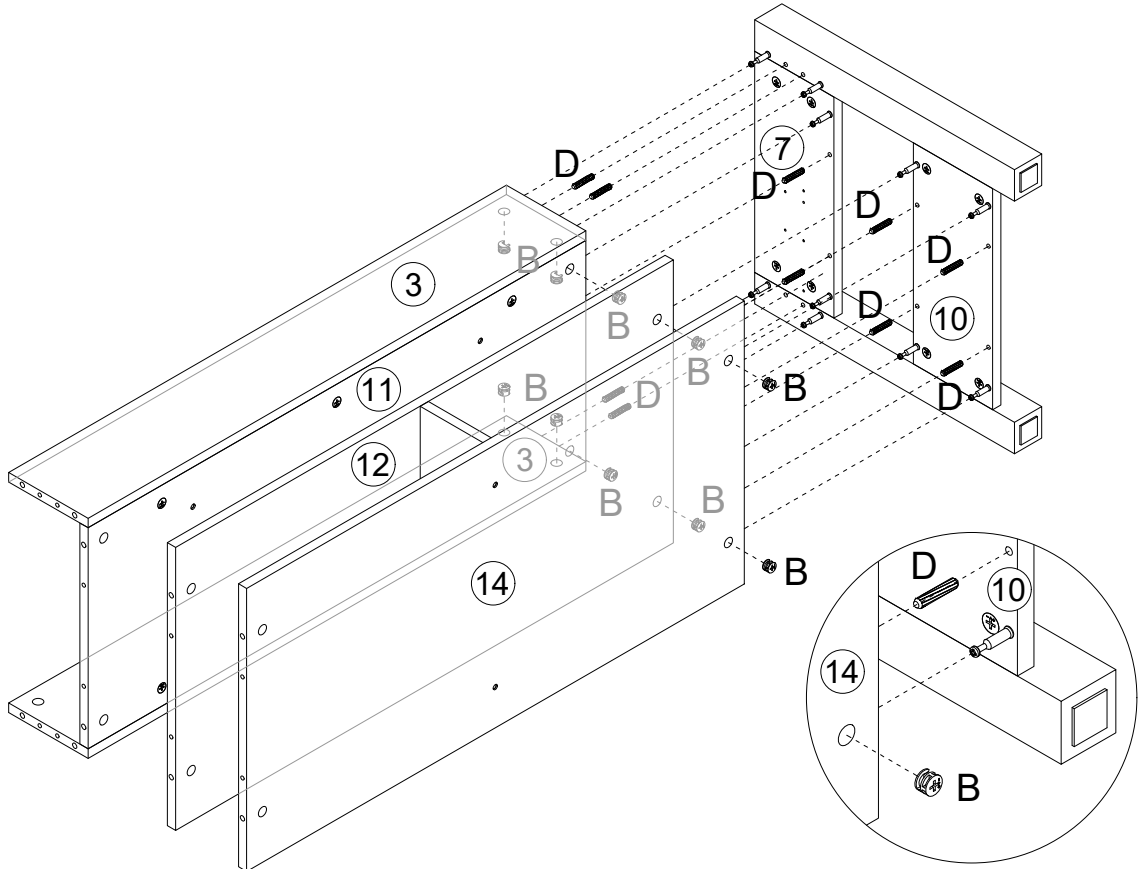

step 7

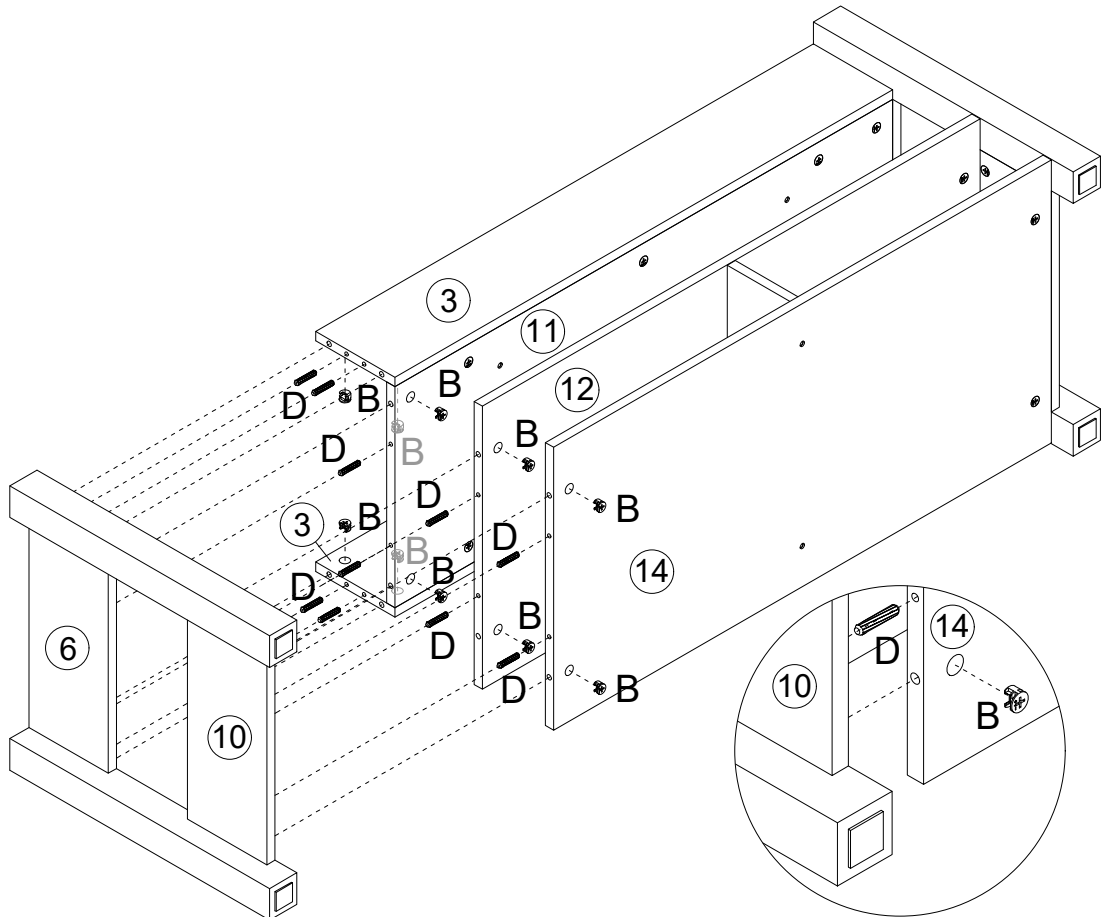

- (B)** 
Ø15*9mm
Cam lock x 10
- (D)** 
6*30mm
Dowel x 10

step 8



- (B)** 
Ø15*9mm
Cam lock x 10
- (D)** 
6*30mm
Dowel x 10

Assembly Instructions

step 9

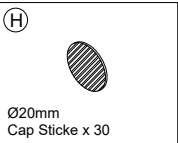
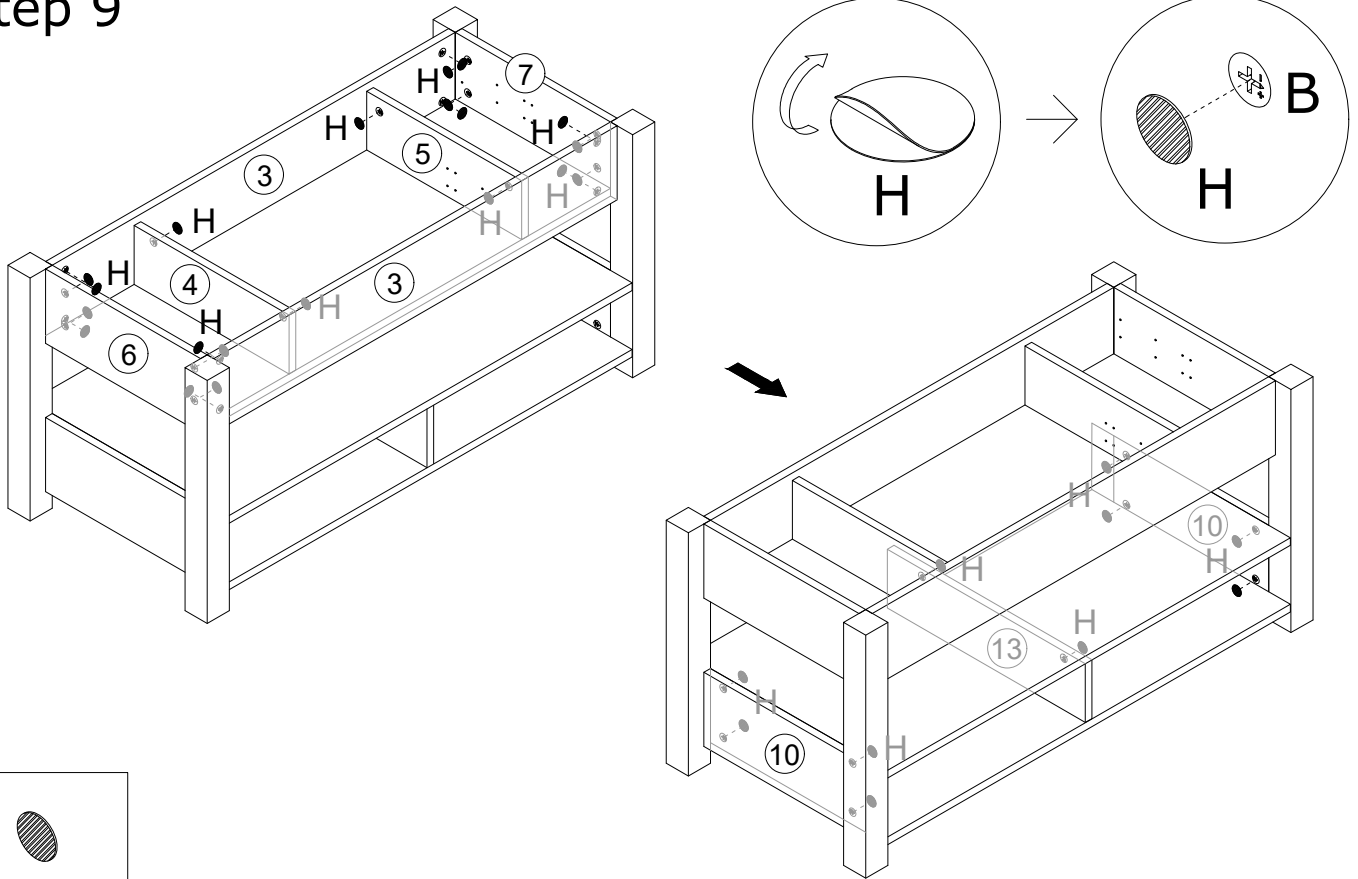

step 10

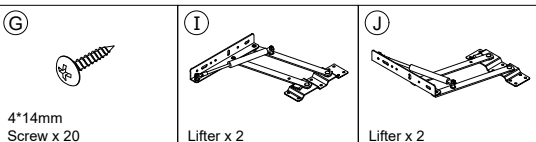
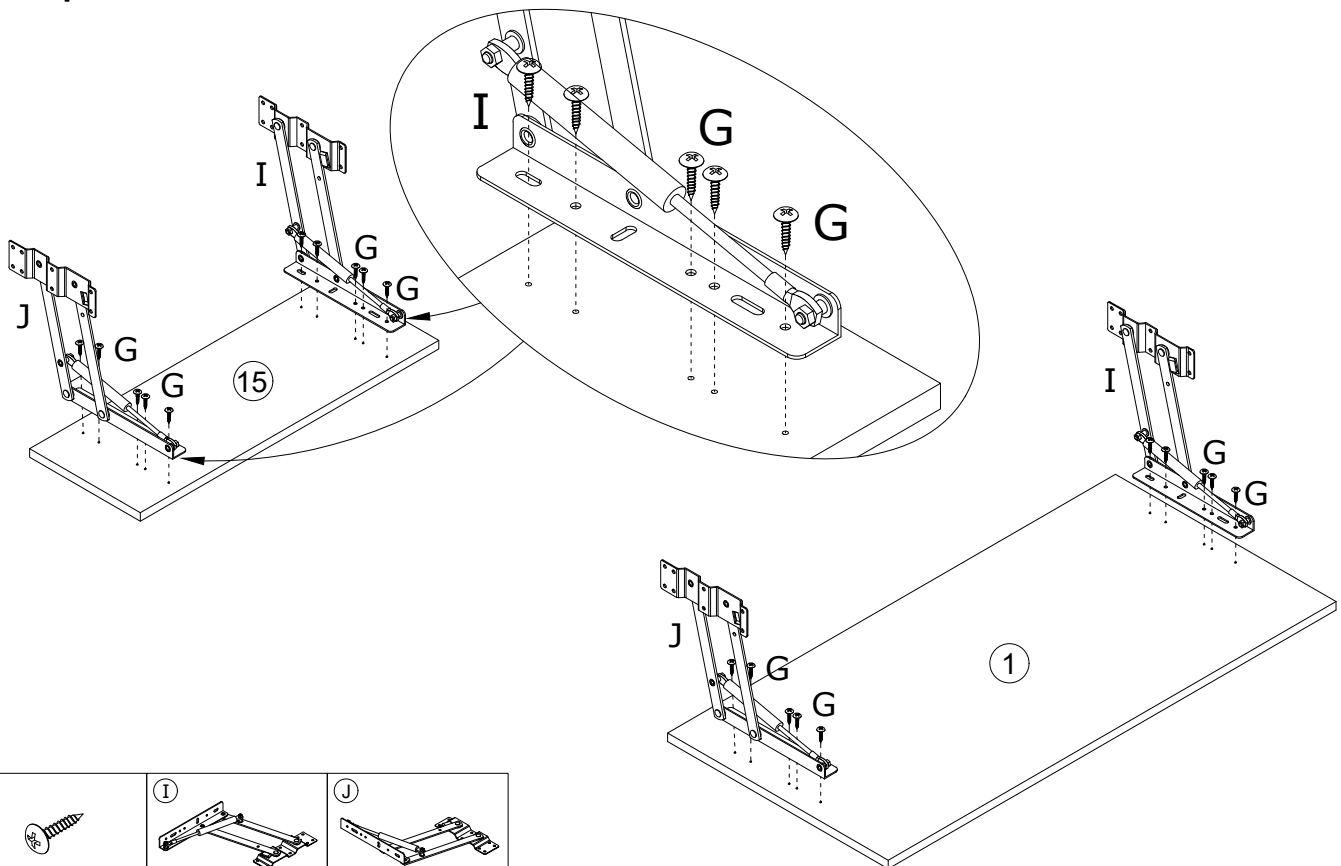

Assembly Instructions

step 11

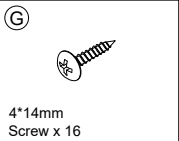
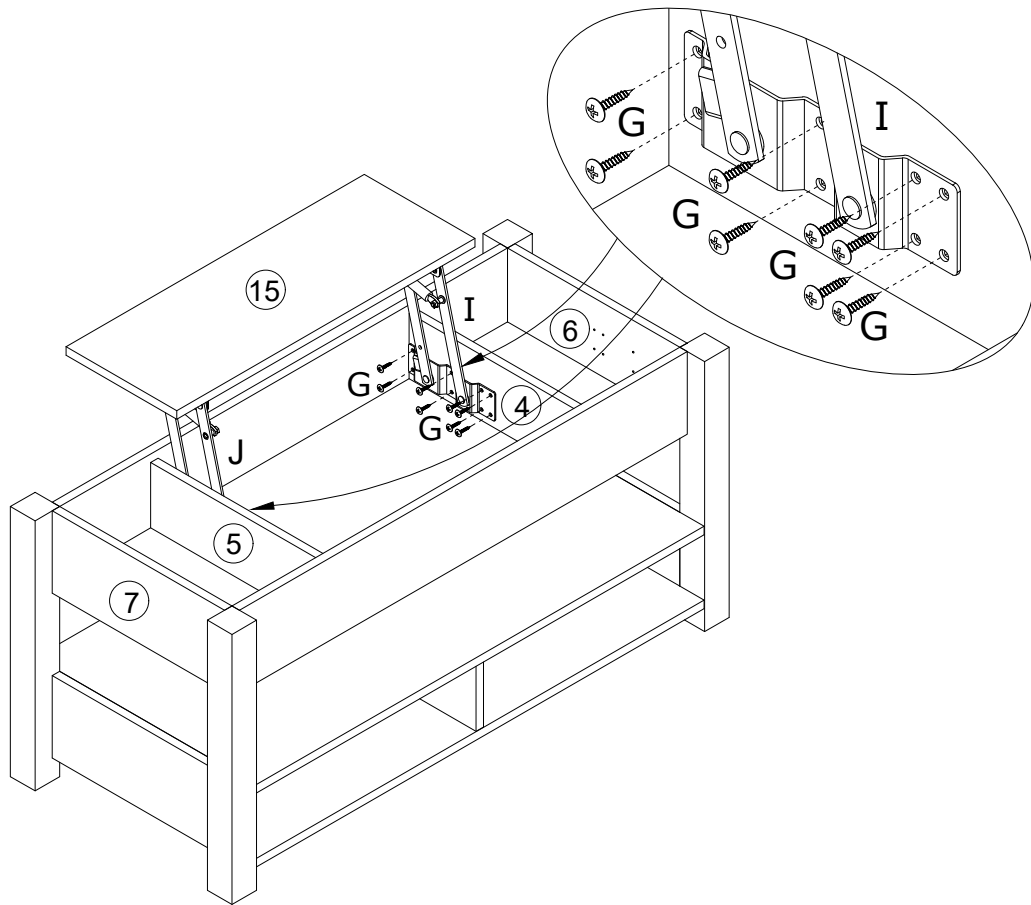

step 12

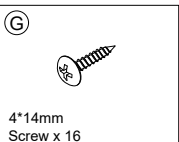
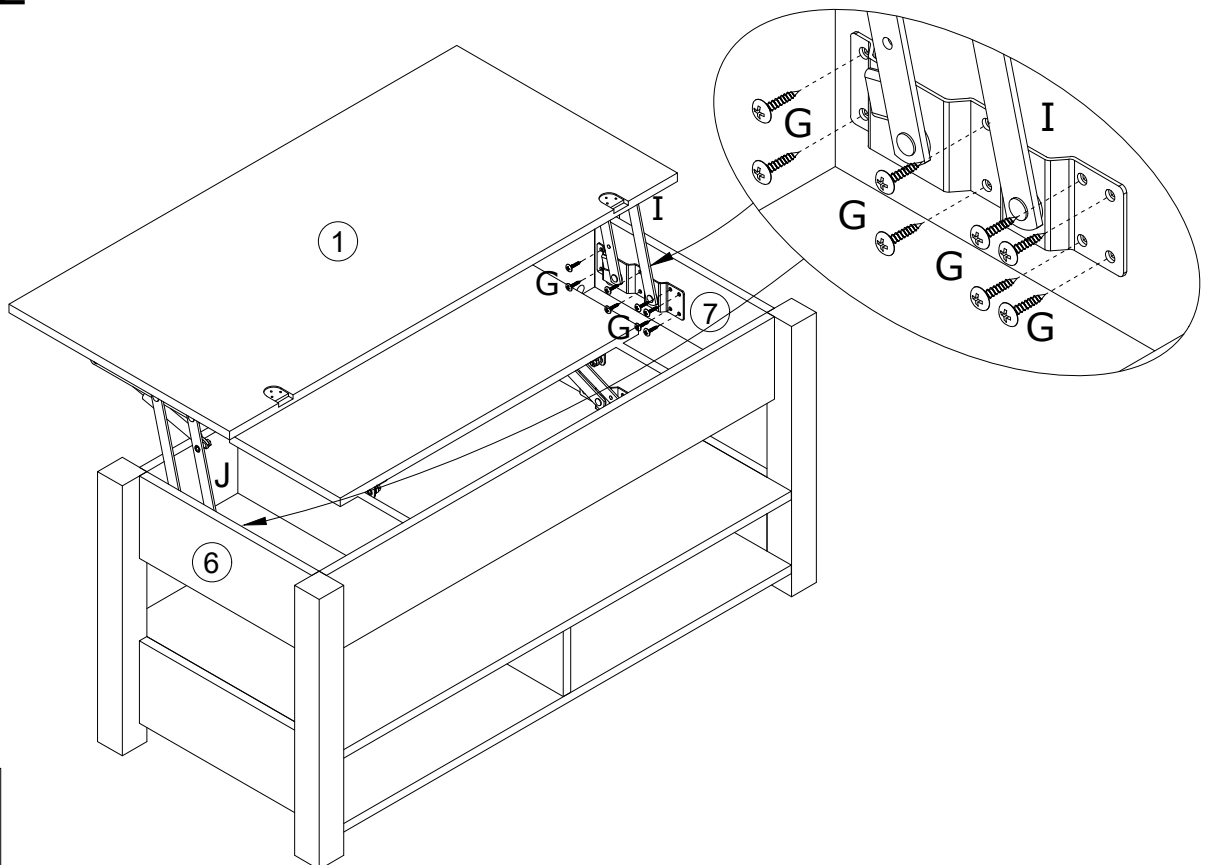

Assembly Instructions

step 13

