

**ASSEMBLY INSTRUCTIONS**  
**COASTER FINE FURNITURE**



*Fine Furniture for every stage of life*

**223521KE (B1-B3)**  
**Eastern King Bed**

# ITEM: 223521KE(B1-B3)



## ASSEMBLY INSTRUCTIONS

### ASSEMBLY TIPS :

1. Remove hardware from box and sort by size.
2. Please check to see that all hardware and parts are present prior to start of assembly.
3. Please follow attached instructions in the same sequence as numbered to assure fast & easy assembly.



### WARNING !

1. Don't attempt to repair or modify parts that are broken or defective. Please contact the store immediately.
2. This product is for home use only and not intended for commercial establishments.



ASSEMBLY TIME

35 MINUTES

## PARTS IDENTIFICATION

### B1 (BOX 1)

|   |                          |  |      |
|---|--------------------------|--|------|
| A | HEADBOARD PANEL          |  | 1PC  |
| B | HEADBOARD TOP DECORATION |  | 1PC  |
| C | HEADBOARD SUPPORT        |  | 2PCS |
| D | LEFT HEADBOARD LEG       |  | 1PC  |
| E | RIGHT HEADBOARD LEG      |  | 1PC  |
| F | EAR PANEL SUPPORT        |  | 2PCS |
| G | HEADBOARD SUPPORT PANEL  |  | 1 PC |

### B2 (BOX 2)

|   |                 |  |     |
|---|-----------------|--|-----|
| H | FOOTBOARD PANEL |  | 1PC |
|---|-----------------|--|-----|

### B3 (BOX 3)

|   |                  |  |       |
|---|------------------|--|-------|
| I | BED SLAT         |  | 5PCS  |
| J | BED SLAT SUPPORT |  | 10PCS |
| K | LEFT BED RAIL    |  | 1PC   |
| L | RIGHT BED RAIL   |  | 1PC   |
| M | FOOTBOARD LEG    |  | 2PCS  |

### NOTE:

Phillips head screw driver is required in the assembly process; however, manufacturer does not provide this item.

# ITEM: 223521KE(B1-B3)



## ASSEMBLY INSTRUCTIONS

### ASSEMBLY TIPS :

1. Remove hardware from box and sort by size.
2. Please check to see that all hardware and parts are present prior to start of assembly.
3. Please follow attached instructions in the same sequence as numbered to assure fast & easy assembly.















### WARNING !

1. Don't attempt to repair or modify parts that are broken or defective. Please contact the store immediately.
2. This product is for home use only and not intended for commercial establishments.

## HARDWARE IDENTIFICATION

### Z-B3 (BOX 3) - HARDWARE PACK IS LOCATED IN 223521KE(B3)

|    |   |   |       |
|----|---|---|-------|
| 1  | <b>ALLEN WRENCH</b><br>(Φ6 - BLK)                   |    | 1PC   |
| 2  | <b>SHORT BOLT</b><br>(Φ6 X 30mm - RBW)              |    | 4PCS  |
| 3  | <b>MEDIUM BOLT</b><br>(Φ6 X 45mm - RBW)             |    | 20PCS |
| 4  | <b>LONG BOLT</b><br>(Φ6 X 60mm - RBW)               |  | 6PCS  |
| 5  | <b>SHORT FLAT HEAD SCREW</b><br>(Φ4 X 16mm - RBW)   |  | 4PCS  |
| 6  | <b>MEDIUM FLAT HEAD SCREW</b><br>(Φ4 X 32mm - RBW)  |  | 10PCS |
| 7  | <b>LONG FLAT HEAD SCREW</b><br>(Φ4 X 45mm - RBW)    |  | 4PCS  |
| 8  | <b>LOCK WASHER</b><br>(Φ6 - RBW)                    |  | 20PCS |
| 9  | <b>SMALL FLAT WASHER</b><br>(Φ7 X 19mm X 2.0 - RBW) |  | 20PCS |
| 10 | <b>BIG FLAT WASHER</b><br>(3/8 x 25 x 1.0 - RBW)    |  | 14PCS |
| 11 | <b>LEVELER</b><br>(M6 x 23mm - RBW)                 |  | 10PCS |
| 12 | <b>WOOL DOWEL</b><br>(M8 X 45MM)                    |  | 4PCS  |

### NOTE:

Phillips head screw driver is required in the assembly process; however, manufacturer does not provide this item.

# ITEM: 223521KE(B1-B3)

## ASSEMBLY INSTRUCTIONS

### STEP 1

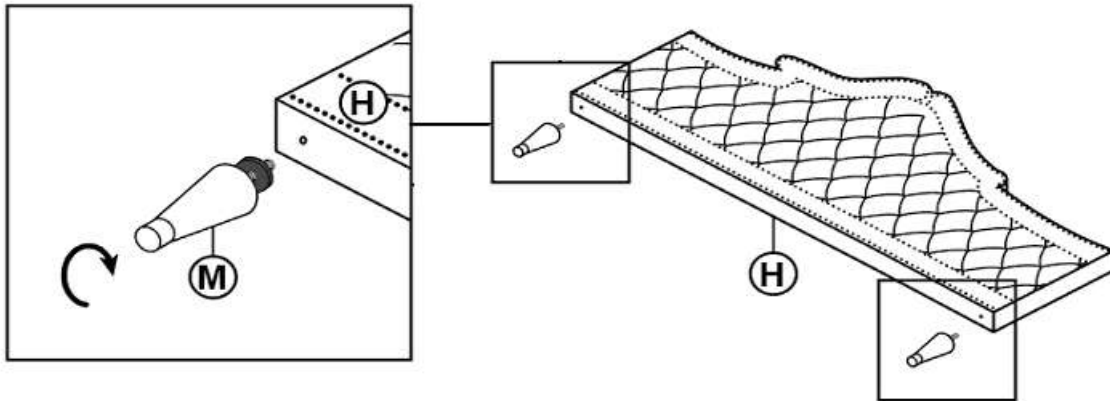

### STEP 2

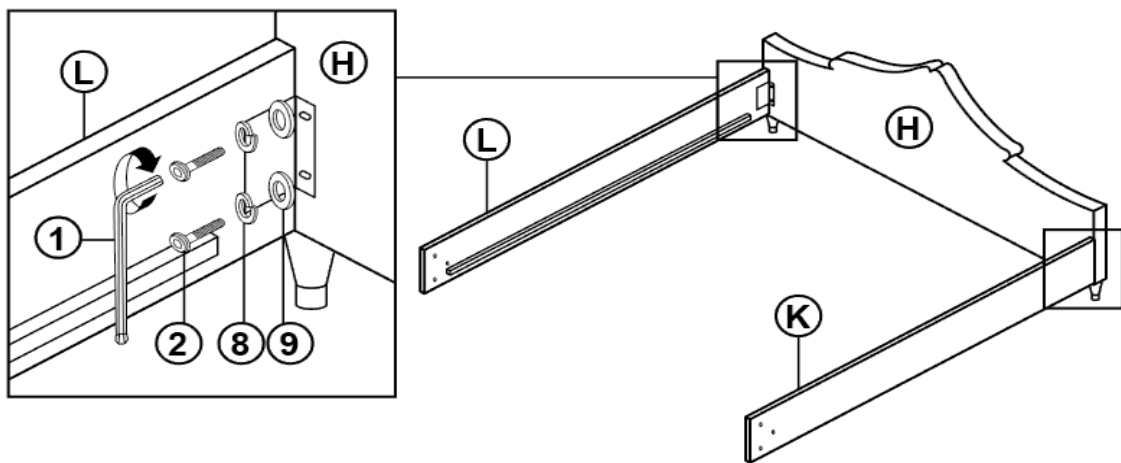

### STEP 3

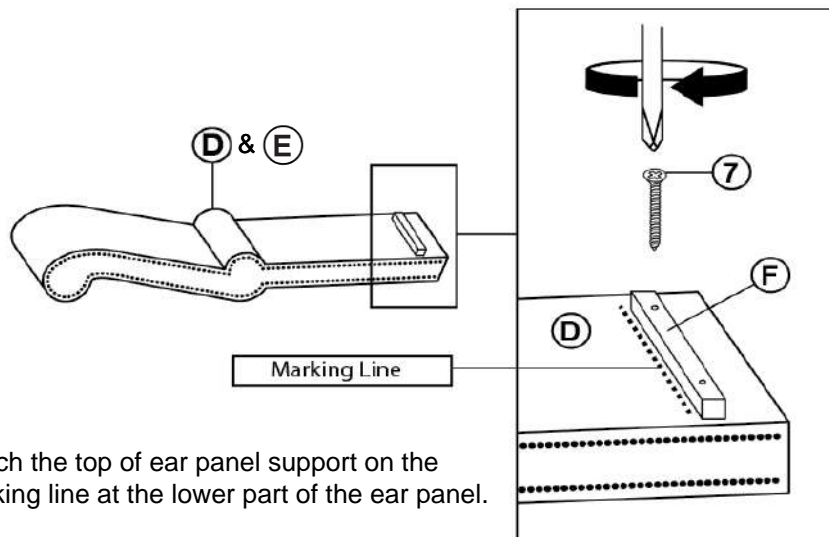

\*Attach the top of ear panel support on the marking line at the lower part of the ear panel.

# ITEM: 223521KE(B1-B3)

## ASSEMBLY INSTRUCTIONS

### STEP 4

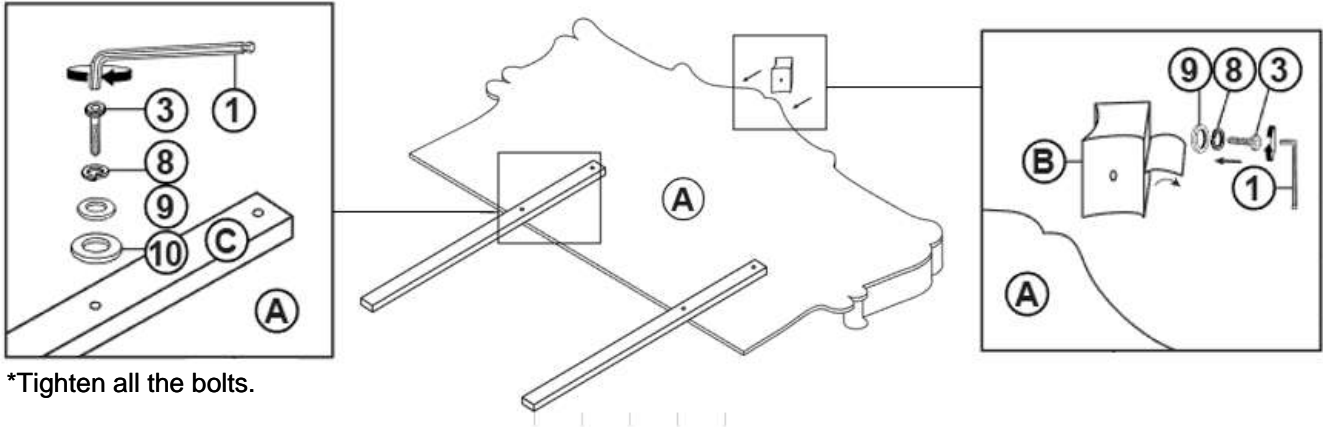

### STEP 5

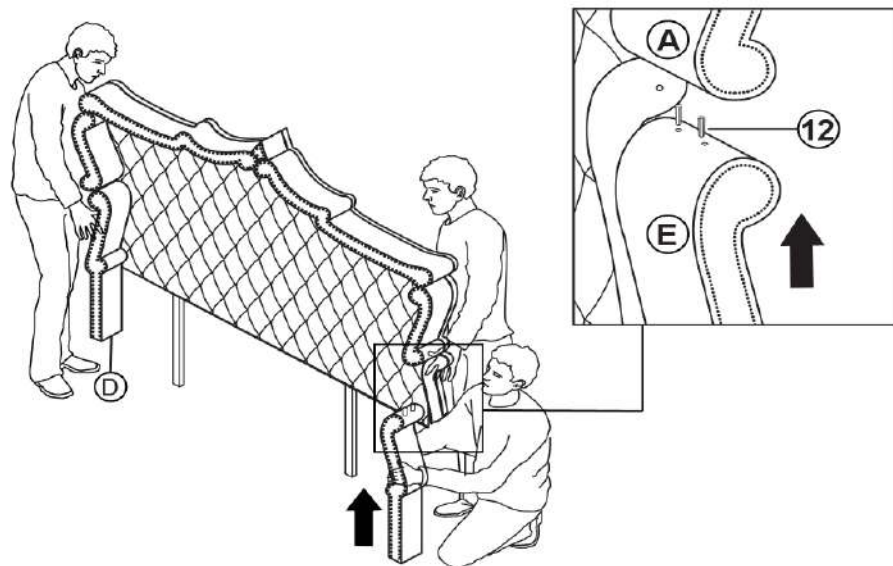

### STEP 6

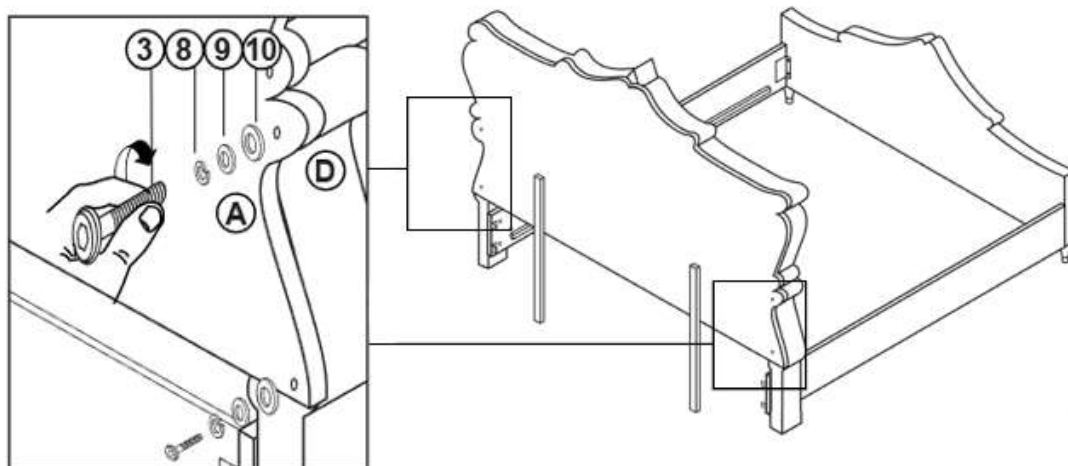

\* Hand tight, do not tighten all the bolts.

# ITEM: 223521KE(B1-B3)



## ASSEMBLY INSTRUCTIONS

### STEP 7

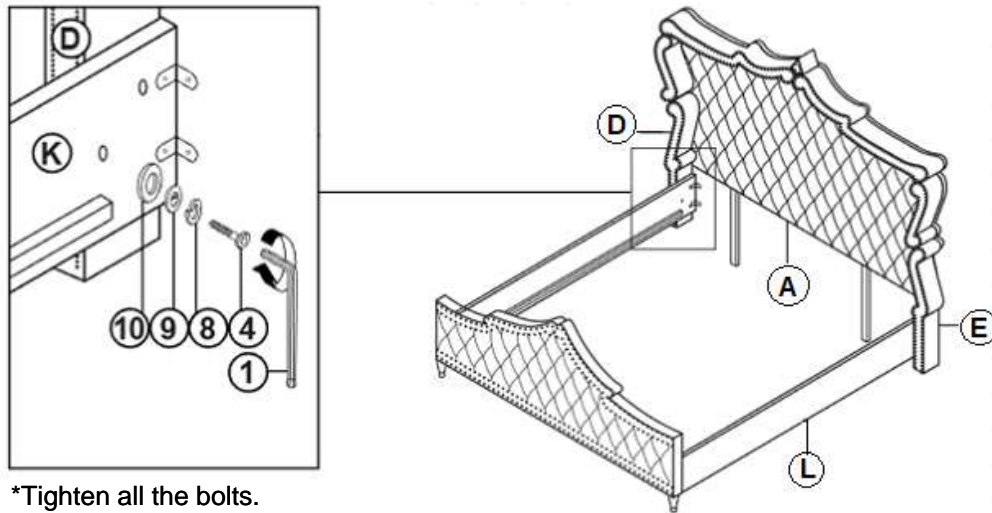

\*Tighten all the bolts.

### STEP 8

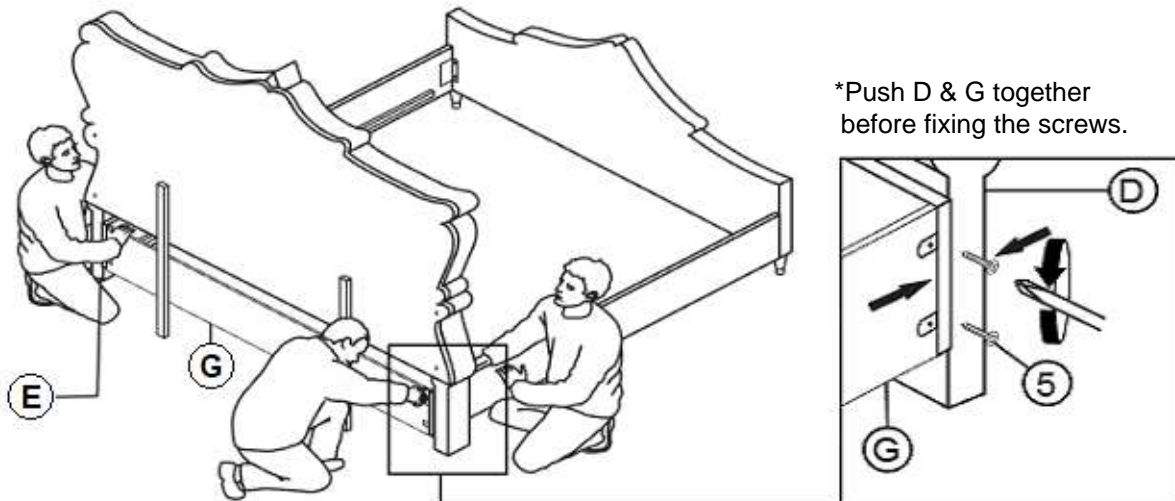

### STEP 9

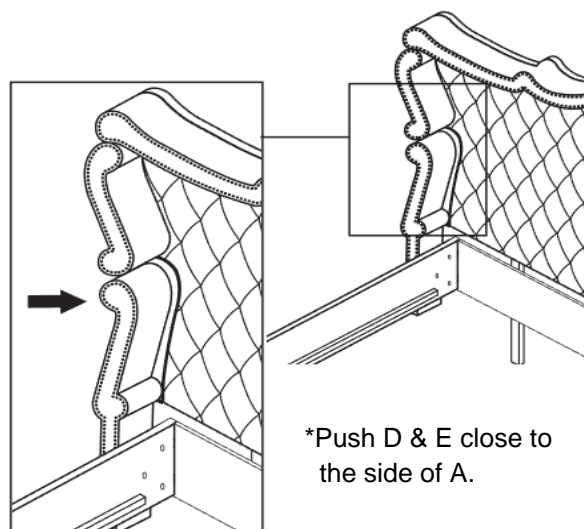

\*Push D & E close to the side of A.



# ITEM: 223521KE(B1-B3)



## ASSEMBLY INSTRUCTIONS

### STEP 10

\* Tighten the bolts at D & E.

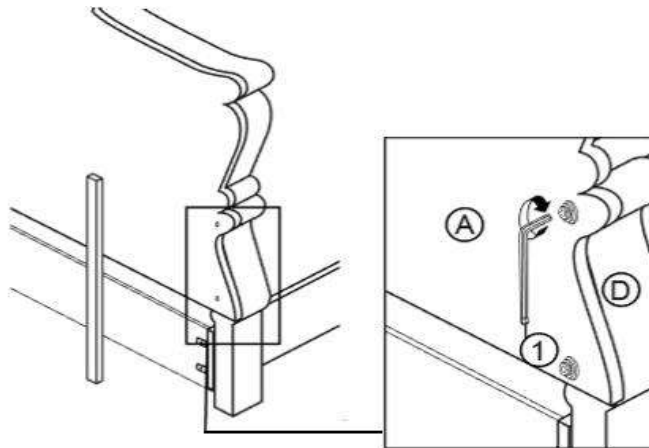

### STEP 11

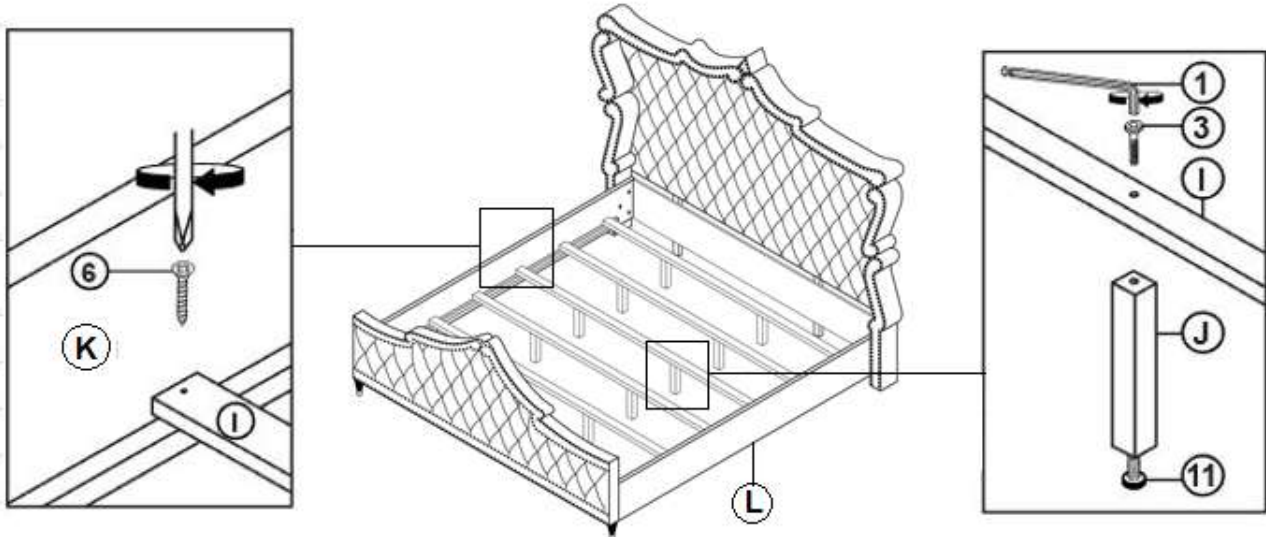

### STEP 12 COMPLETE

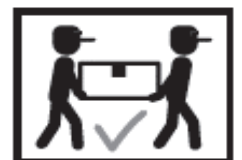

ITEM: **223521KE(B1-B3)**



Inner Size : 77"W x 81.50"D

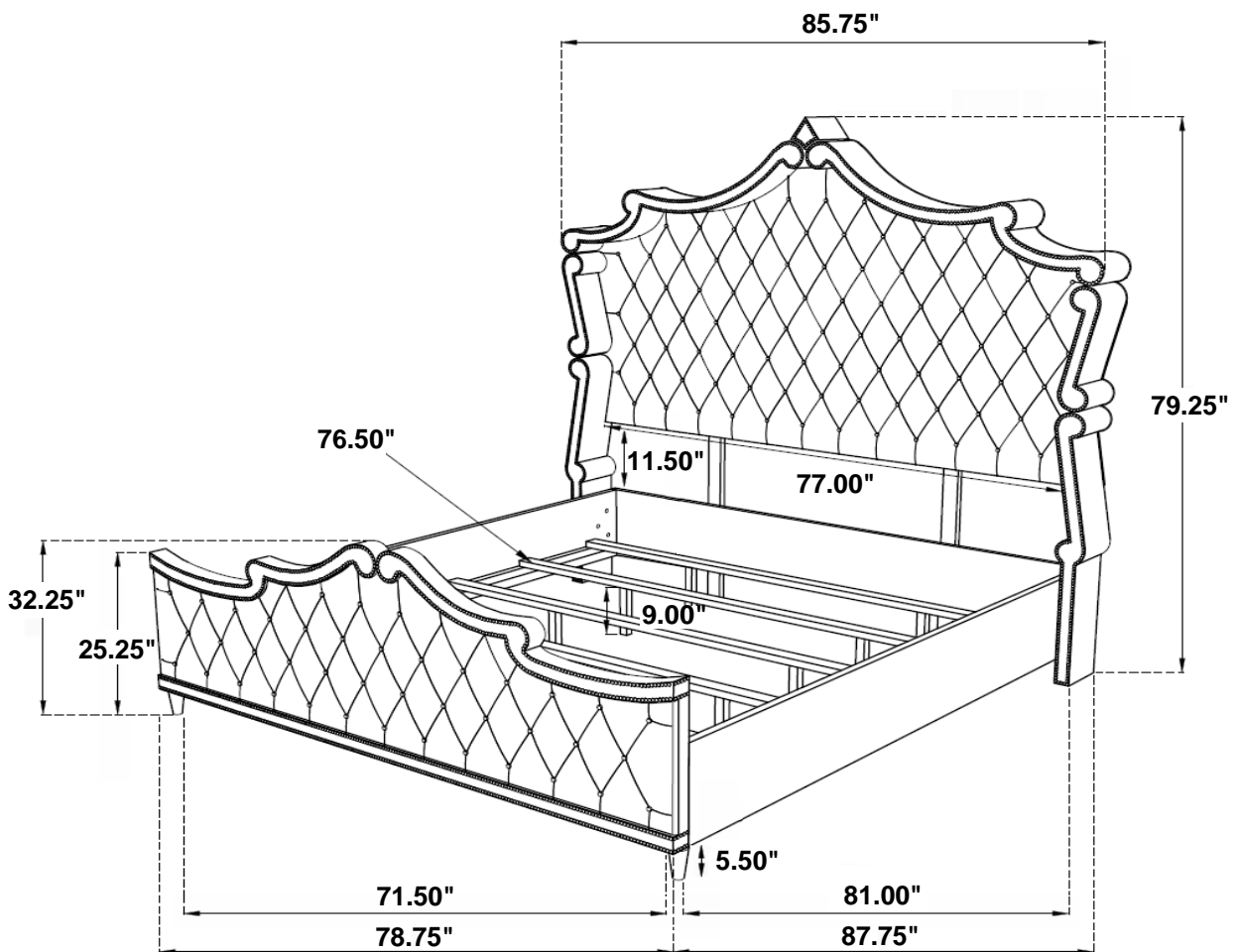

Note: Dimension tolerance  $\pm 5\%$

*ASSEMBLY INSTRUCTIONS*  
*COASTER FINE FURNITURE*



*Fine Furniture for every stage of life*

**223522**  
**Nightstand**

ITEM: **223522**



## ASSEMBLY INSTRUCTIONS

### ASSEMBLY TIPS :

1. Remove hardware from box and sort by size.
2. Please check to see that all hardware and parts are present prior to start of assembly.
3. Please follow attached instructions in the same sequence as numbered to assure fast & easy assembly.



### WARNING !

1. Don't attempt to repair or modify parts that are broken or defective. Please contact the store immediately.
2. This product is for home use only and not intended for commercial establishments.



ASSEMBLY TIME

15 MINUTES

## PARTS IDENTIFICATION

A NIGHTSTAND

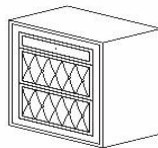

1PC

B LEG



4PCS

C ADAPTER



1PC

### NOTE:

Phillips head screw driver is required in the assembly process; however, manufacturer does not provide this item.

ITEM: **223522**

**ASSEMBLY INSTRUCTIONS**

**STEP 1**

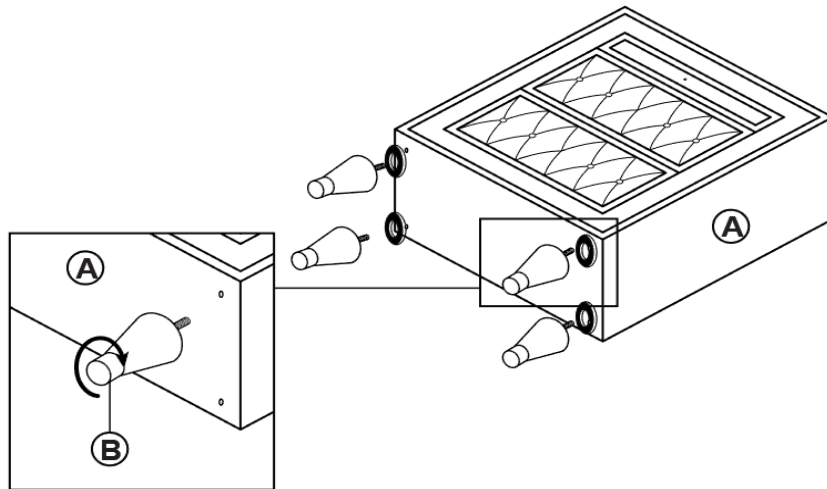

**STEP 2**

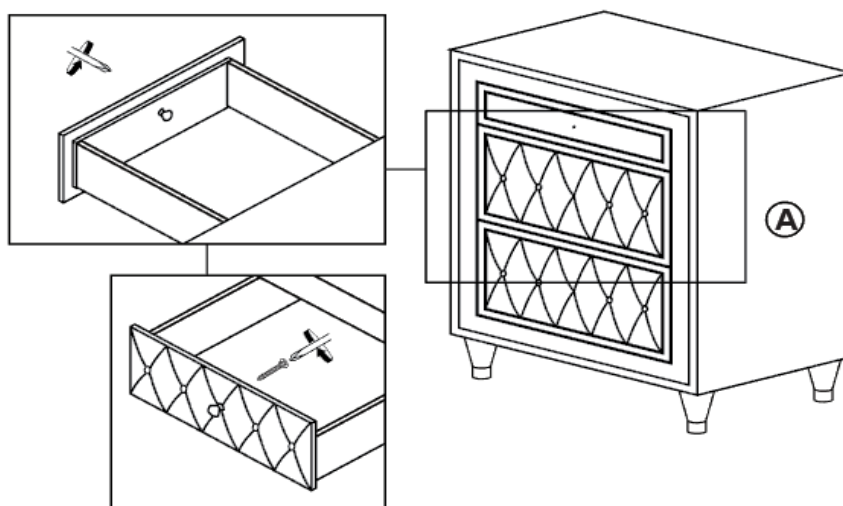

ITEM: **223522**

**ASSEMBLY INSTRUCTIONS**

**STEP 3**

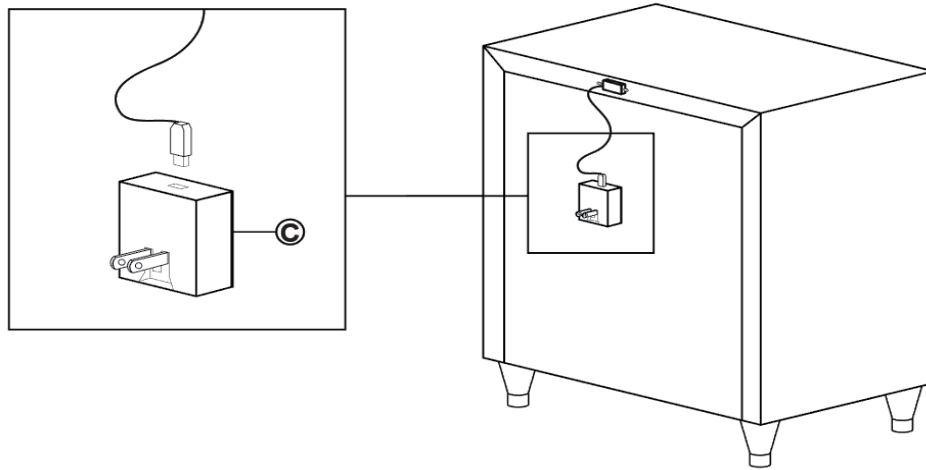

**STEP 4**  
**COMPLETE**

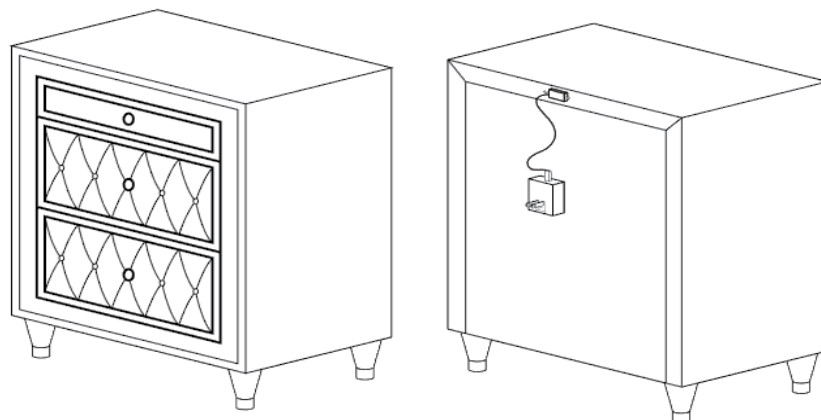

## ANTI-TIPPING INSTALLMENT INSTRUCTIONS

### FURNITURE TIPPING RESTRAINT

#### WARNING

Injury may result from tipping furniture.  
This restraint may protect against tipping furniture.  
Do not allow children to climb on furniture.  
This restraint is not a substitute for proper adult supervision.  
Failure to detach this restraint before moving the furniture may result in injury and damage.

This tip restraint must be attached to a wall stud using long screw enclosed.

#### STEP 1

Attach a bracket securely to the back top rail of the furniture using short screw provided, through the smaller hole.

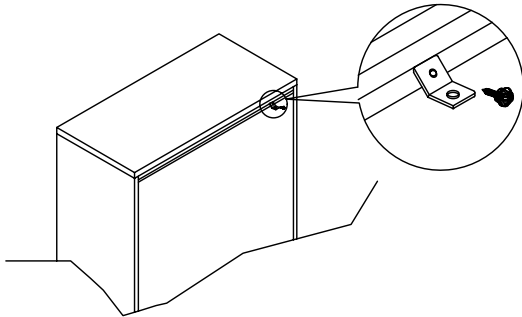

#### STEP 2

Locate the other bracket on the wall over a wall stud and two inches below the mounting bracket secured to the back of the furniture. Attach the wall stud using the long screw provided, through the smaller hole.

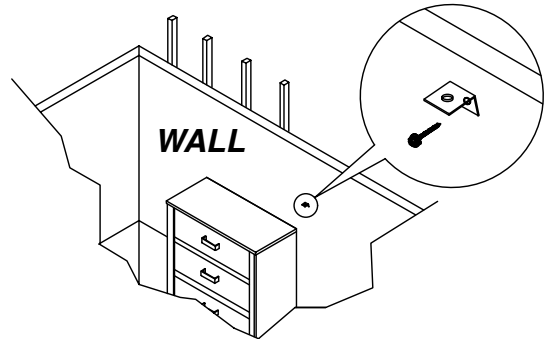

#### STEP 3

Place the furniture into position so both mounting brackets are vertically in line. Lace the end of the restraint strap through the larger hole in each mounting bracket. Bring both ends together and slide the flat end through the locking end and draw it through until all slack is removed. Confirm that the strap is securely laced and locked.

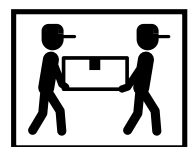
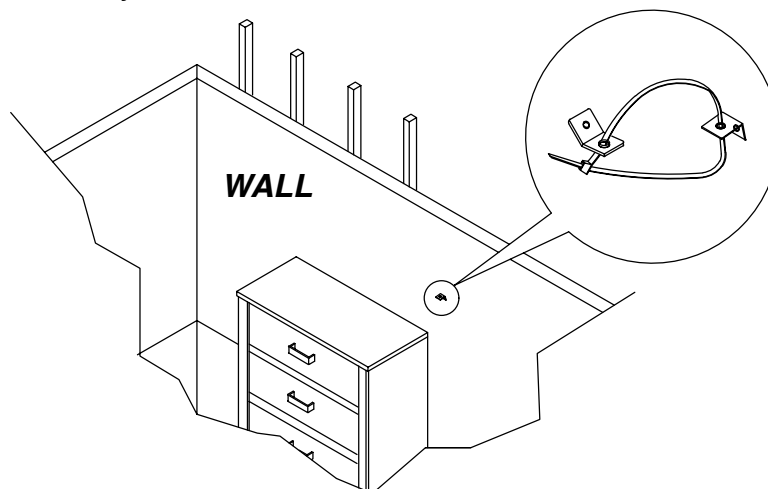

ITEM: **223522**



Inner Size of Drawer A : 19.25"W X 12.50"D X 2.50"H X 0.25"T

Inner Size of Drawer B : 19.25"W X 13.00"D X 5.00"H X 0.25"T

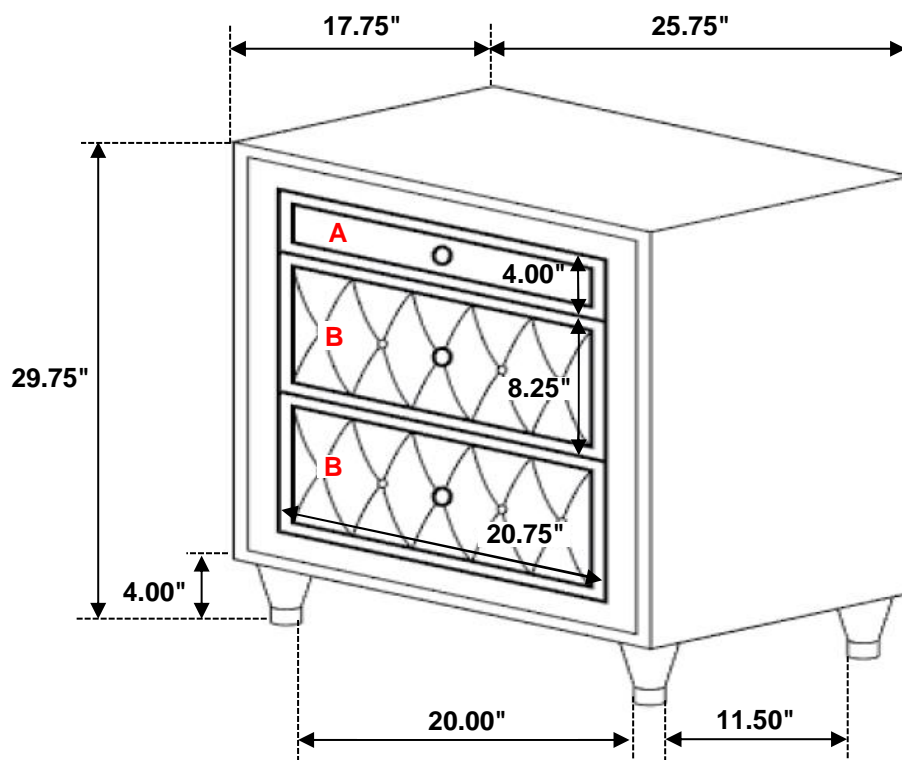

Note : Dimension tolerance  $\pm 5\%$

**ASSEMBLY INSTRUCTIONS**  
**COASTER FINE FURNITURE**



*Fine Furniture for every stage of life*

**223523**  
**Dresser**

ITEM: **223523**



## ASSEMBLY INSTRUCTIONS

### ASSEMBLY TIPS:

1. Remove hardware from box and sort by size.
2. Please check to see that all hardware and parts are present prior to start of assembly.
3. Please follow attached instructions in the same sequence as numbered to assure fast & easy assembly.



### WARNING!

1. Don't attempt to repair or modify parts that are broken or defective. Please contact the store immediately.
2. This product is for home use only and not intended for commercial establishments.



ASSEMBLY TIME

15 MINUTES

## PARTS IDENTIFICATION

A DRESSER

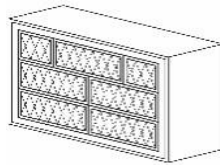

1PC

B LEG



4PCS

C LEG SUPPORT



1PC

### NOTE:

Phillips head screw driver is required in the assembly process; however, manufacturer does not provide this item.

ITEM: **223523**

**ASSEMBLY INSTRUCTIONS**

**STEP 1**

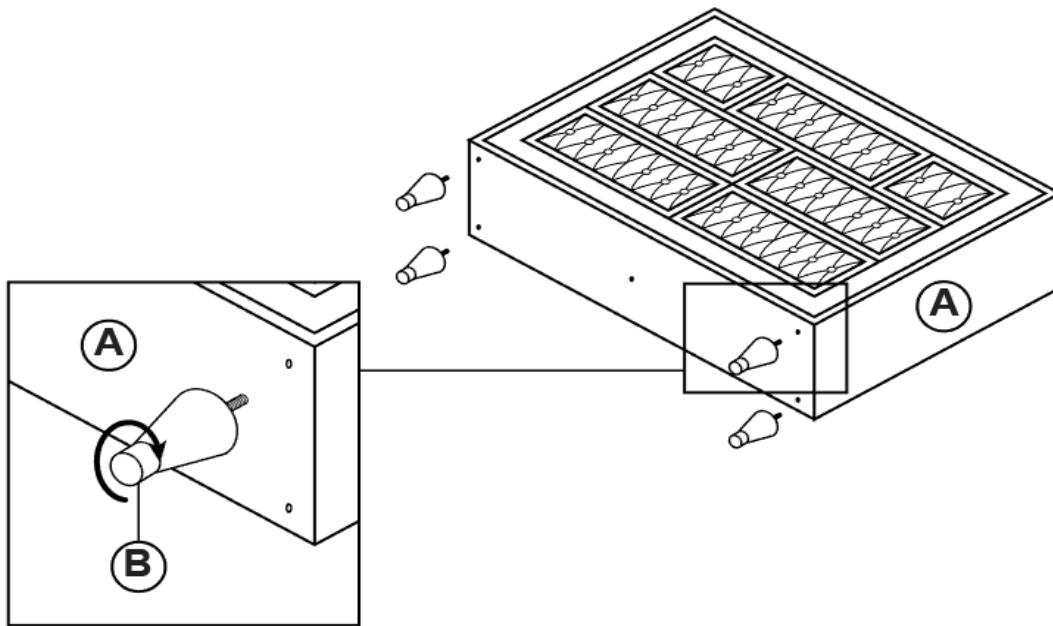

**STEP 2**

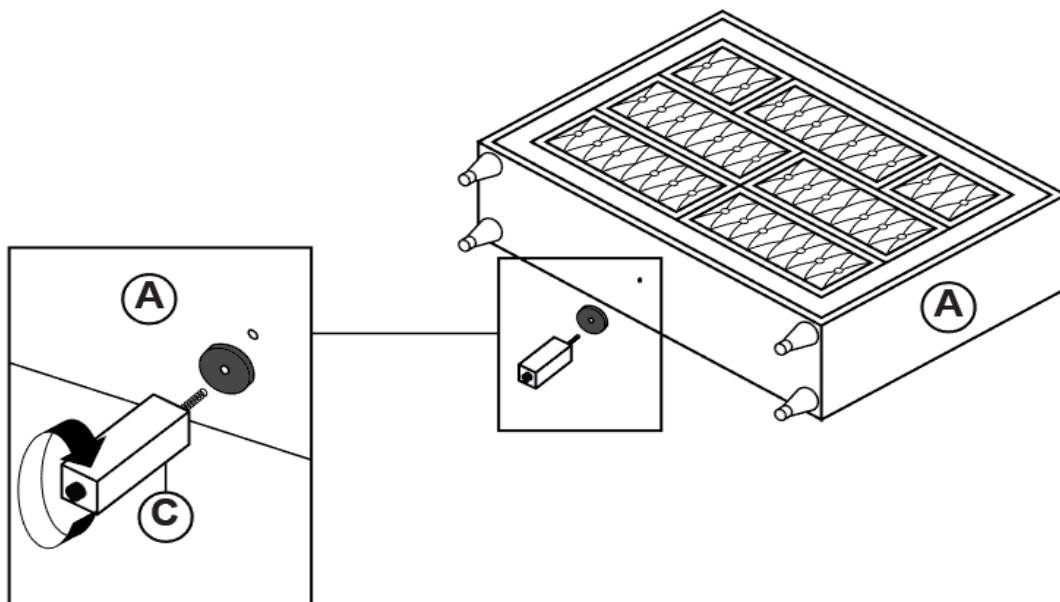

ITEM: **223523**



## ASSEMBLY INSTRUCTIONS

### STEP 3

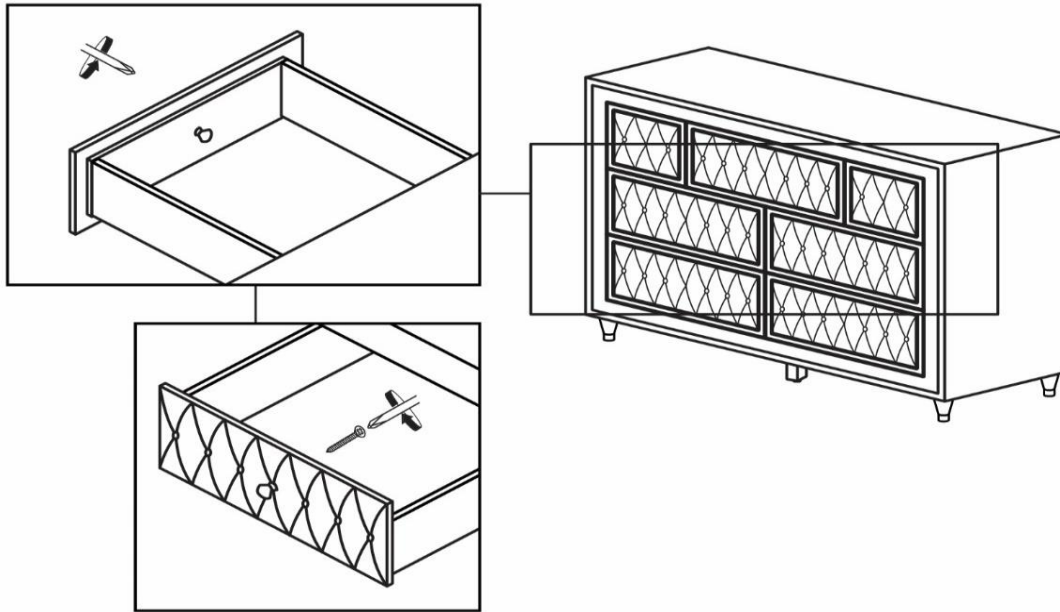

### STEP 4 **COMPLETE**

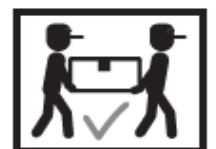
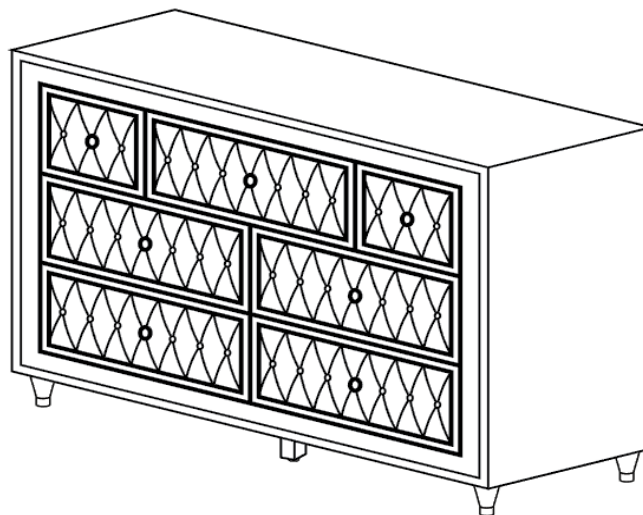

## ANTI-TIPPING INSTALLMENT INSTRUCTIONS

### FURNITURE TIPPING RESTRAINT

#### WARNING

Injury may result from tipping furniture.  
This restraint may protect against tipping furniture.  
Do not allow children to climb on furniture.  
This restraint is not a substitute for proper adult supervision.  
Failure to detach this restraint before moving the furniture may result in injury and damage.

This tip restraint must be attached to a wall stud using long screw enclosed.

#### **STEP 1**

Attach a bracket securely to the back top rail of the furniture using short screw provided, through the smaller hole.

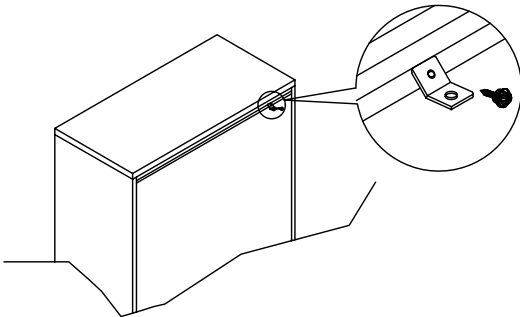

#### **STEP 2**

Locate the other bracket on the wall over a wall stud and two inches below the mounting bracket secured to the back of the furniture. Attach the wall stud using the long screw provided, through the smaller hole.

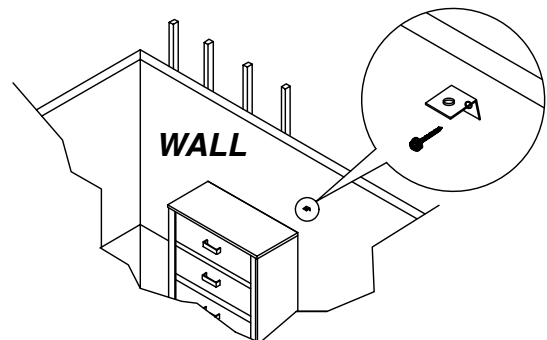

#### **STEP 3**

Place the furniture into position so both mounting brackets are vertically in line. Lace the end of the restraint strap through the larger hole in each mounting bracket. Bring both ends together and slide the flat end through the locking end and draw it through until all slack is removed. Confirm that the strap is securely laced and locked.

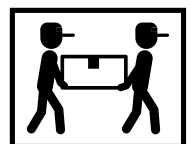
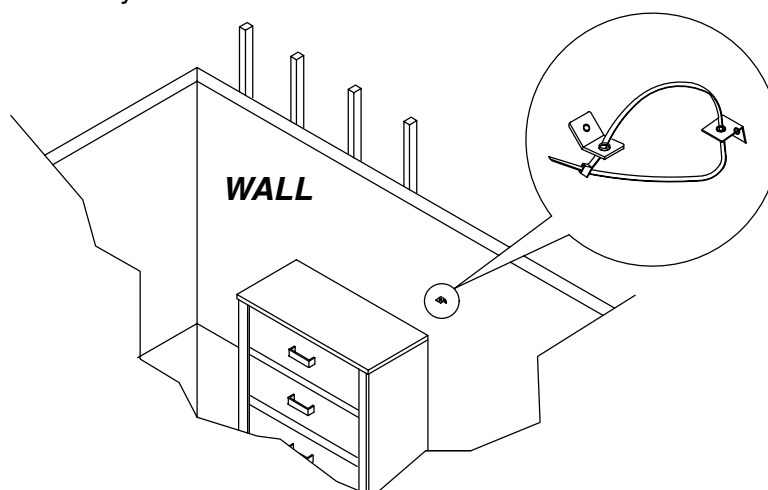

ITEM: **223523**



Inner Size of Drawer A : 11.75"W X 12.75"D X 5.00"H X 0.25"T

Inner Size of Drawer B : 26.00"W X 12.75"D X 5.00"H X 0.25"T

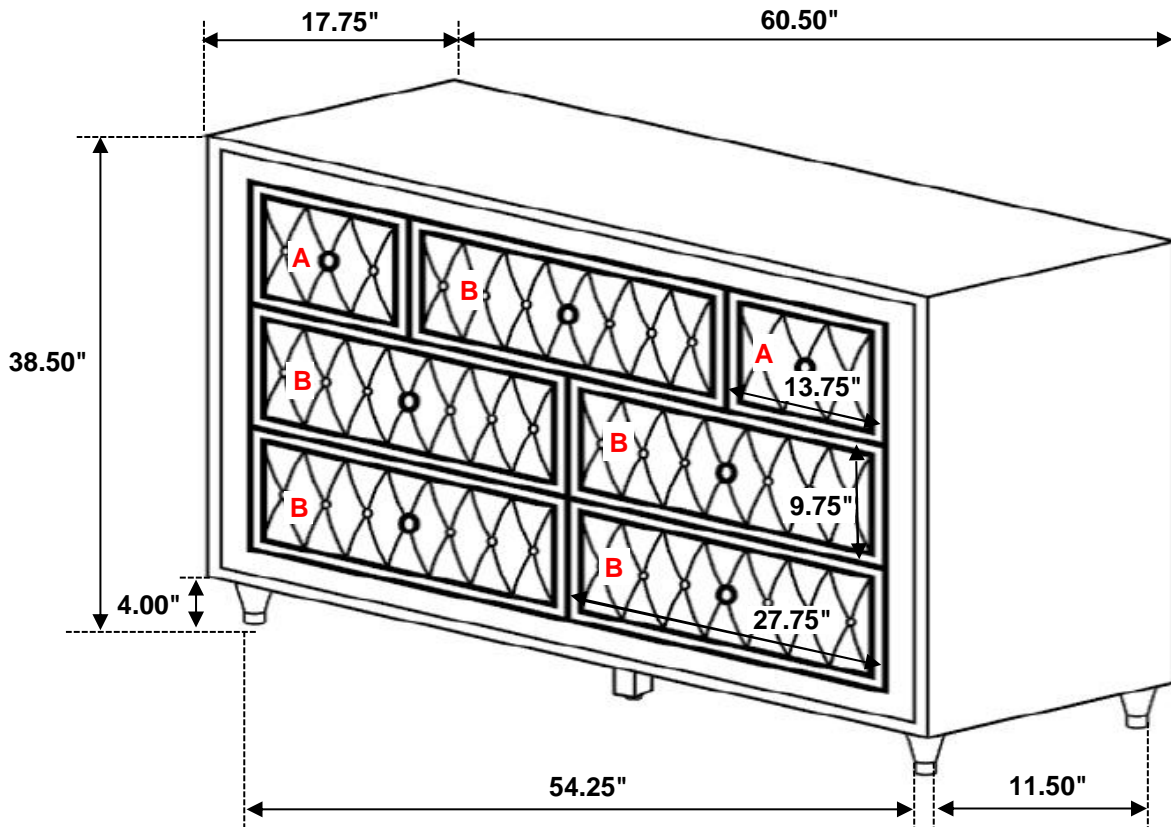

Note : Dimension tolerance  $\pm 5\%$

**ASSEMBLY INSTRUCTIONS**  
**COASTER FINE FURNITURE**



*Fine Furniture for every stage of life*

**223524**  
**Mirror**

ITEM: **223524**

## ASSEMBLY INSTRUCTIONS

### ASSEMBLY TIPS:

1. Remove hardware from box and sort by size.
2. Please check to see that all hardware and parts are present prior to start of assembly.
3. Please follow attached instructions in the same sequence as numbered to assure fast & easy assembly.



### WARNING!

1. Don't attempt to repair or modify parts that are broken or defective. Please contact the store immediately.
2. This product is for home use only and not intended for commercial establishments.



**ASSEMBLY TIME**

**15 MINUTES**

## PARTS IDENTIFICATION

**A MIRROR**



**1PC**

**B MIRROR SUPPORT  
(PACKED WITH MIRROR)**



**2PCS**

**C DRESSER  
\* FROM BOX ITEM# 223523**

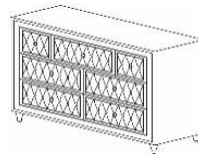

**1PC**

## HARDWARE IDENTIFICATION

**1 ALLEN WRENCH  
(Φ6 - ZINK)**



**1PC**

**2 BOLT  
(Φ6 X 40mm - RBW)**

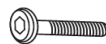

**8PCS**

**3 LOCK WASHER  
(Φ6 - RBW)**



**8PCS**

**4 MEDIUM FLAT WASHER  
(Φ7 X 19mm X 2.0 - RBW)**



**8PCS**

### NOTE:

Phillips head screw driver is required in the assembly process; however, manufacturer does not provide this item.

ITEM: **223524**

**ASSEMBLY INSTRUCTIONS**

**STEP 1**

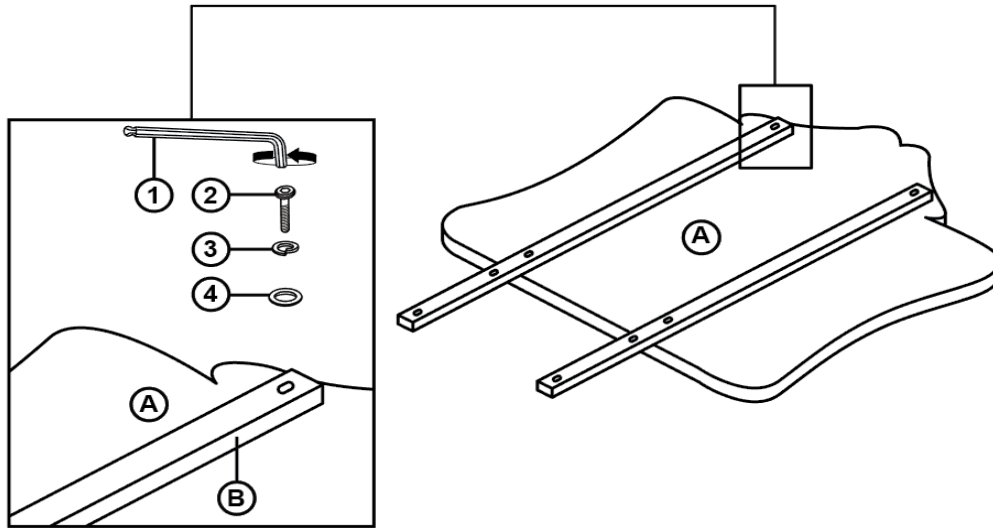

**STEP 2**

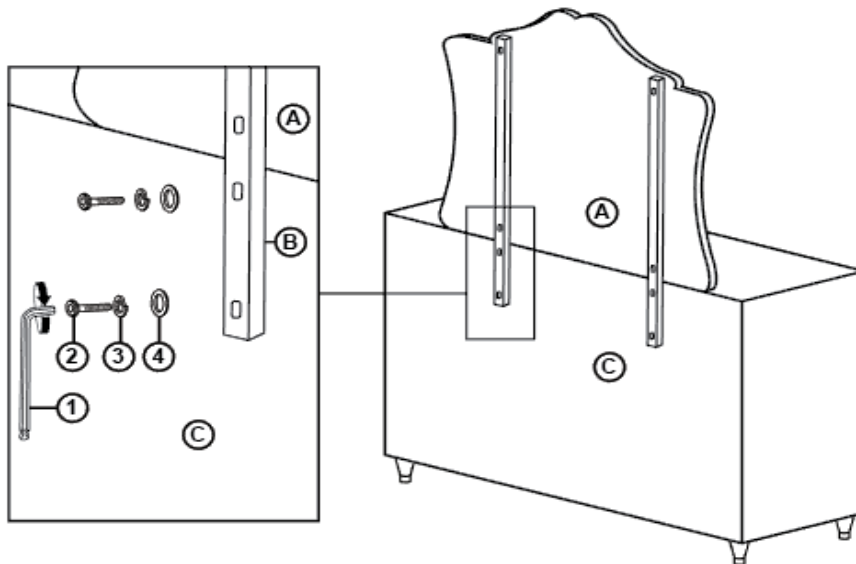

**STEP 3**  
**COMPLETE**

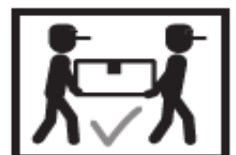
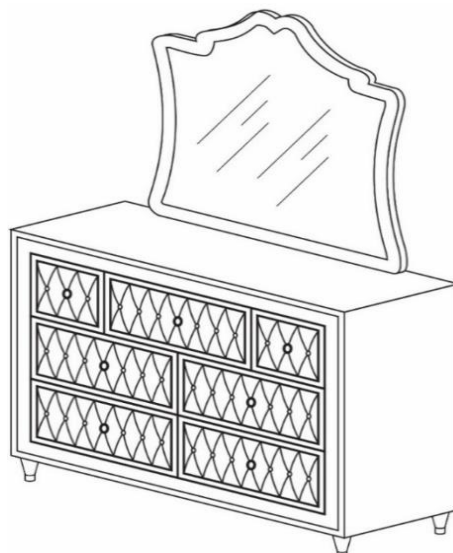

ITEM: 223524

**COASTER**  
FINE FURNITURE

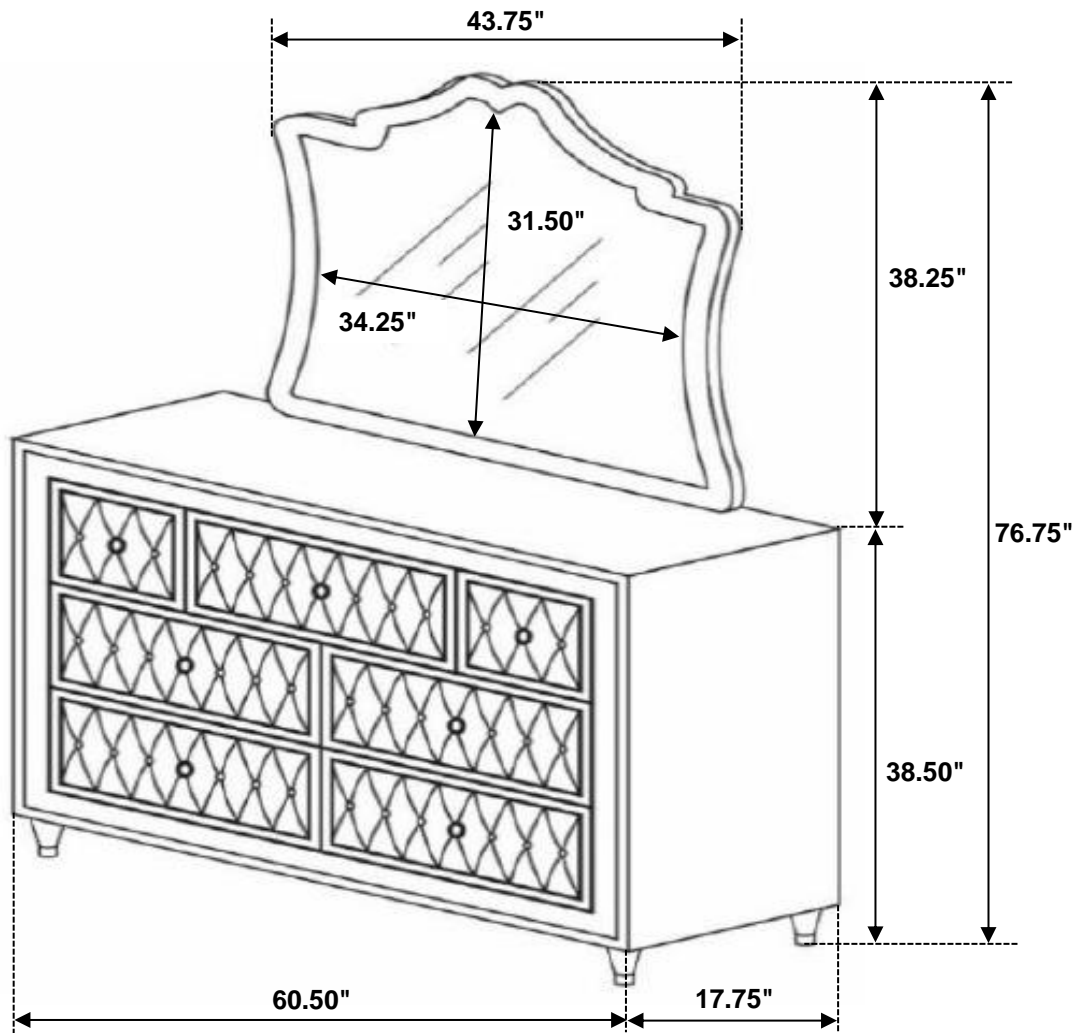

Note : Dimension tolerance  $\pm 5\%$

*ASSEMBLY INSTRUCTIONS*  
*COASTER FINE FURNITURE*



*Fine Furniture for every stage of life*

**223525**  
**Chest**

ITEM: **223525**



## ASSEMBLY INSTRUCTIONS

### ASSEMBLY TIPS:

1. Remove hardware from box and sort by size.
2. Please check to see that all hardware and parts are present prior to start of assembly.
3. Please follow attached instructions in the same sequence as numbered to assure fast & easy assembly.



### WARNING!

1. Don't attempt to repair or modify parts that are broken or defective. Please contact the store immediately.
2. This product is for home use only and not intended for commercial establishments.



ASSEMBLY TIME

15 MINUTES

## PARTS IDENTIFICATION

A CHEST

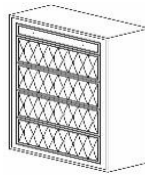

1PC

B LEG



4PCS

### NOTE:

Phillips head screw driver is required in the assembly process; however, manufacturer does not provide this item.

ITEM: **223525**

**ASSEMBLY INSTRUCTIONS**

**STEP 1**

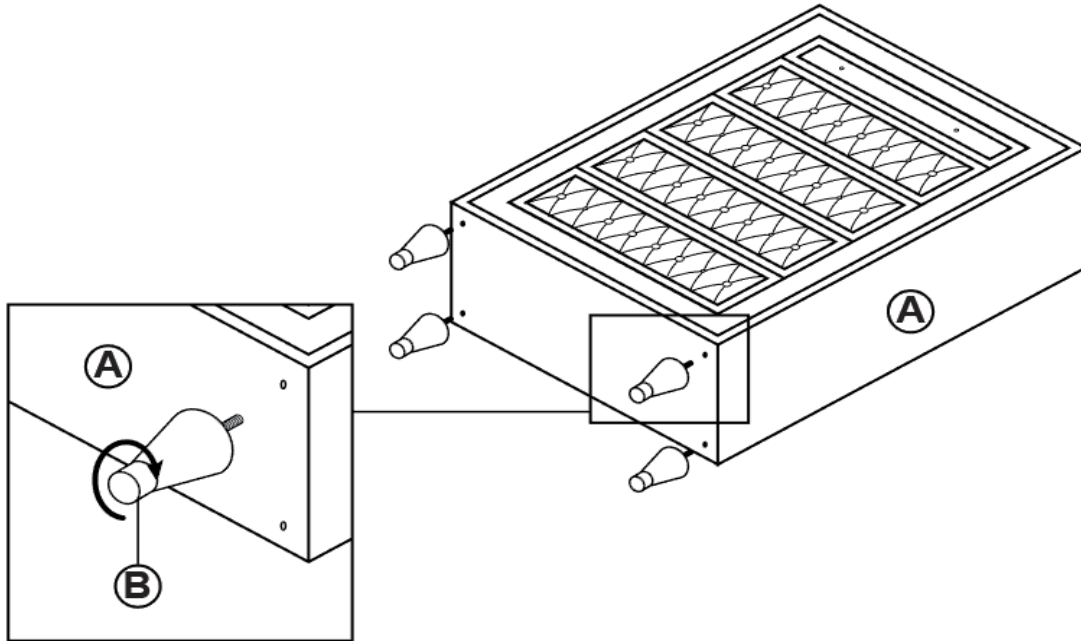

**STEP 2**

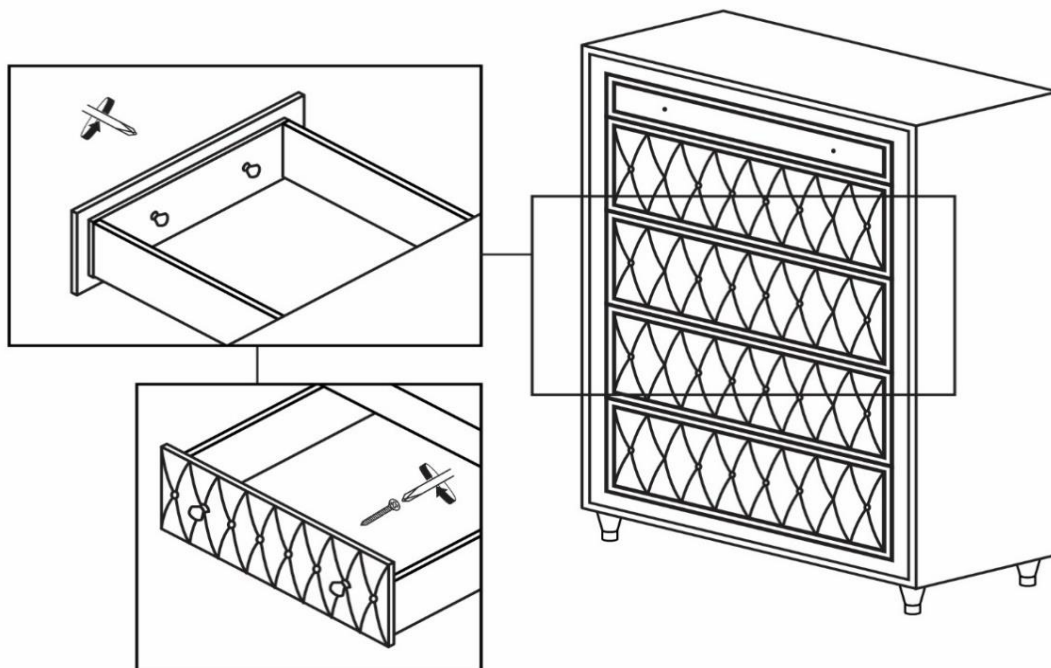

ITEM: **223525**



## ASSEMBLY INSTRUCTIONS

### STEP 3 COMPLETE

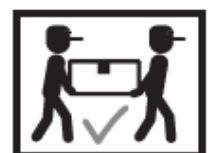
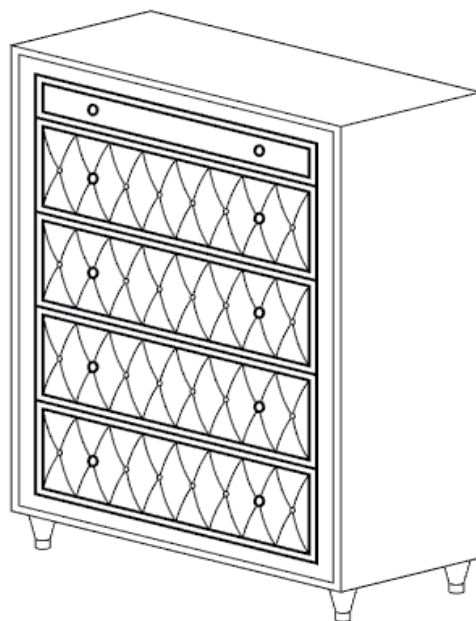

## ANTI-TIPPING INSTALLMENT INSTRUCTIONS

### FURNITURE TIPPING RESTRAINT

#### WARNING

Injury may result from tipping furniture.  
This restraint may protect against tipping furniture.  
Do not allow children to climb on furniture.  
This restraint is not a substitute for proper adult supervision.  
Failure to detach this restraint before moving the furniture may result in injury and damage.

This tip restraint must be attached to a wall stud using long screw enclosed.

#### STEP 1

Attach a bracket securely to the back top rail of the furniture using short screw provided, through the smaller hole.

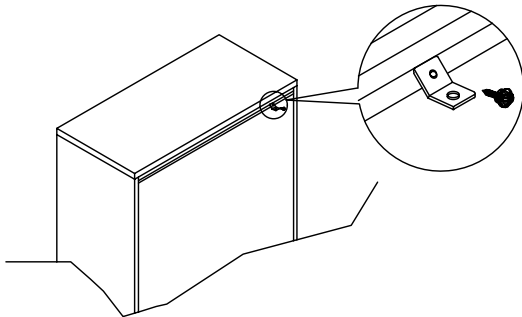

#### STEP 2

Locate the other bracket on the wall over a wall stud and two inches below the mounting bracket secured to the back of the furniture. Attach the wall stud using the long screw provided, through the smaller hole.

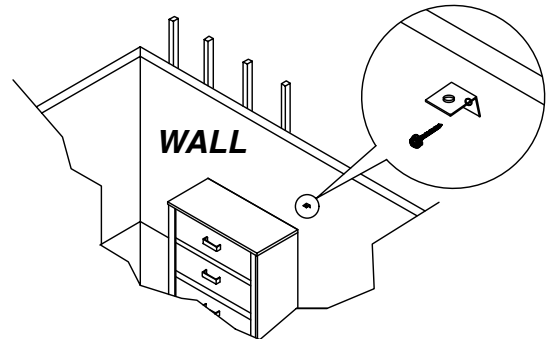

#### STEP 3

Place the furniture into position so both mounting brackets are vertically in line. Lace the end of the restraint strap through the larger hole in each mounting bracket. Bring both ends together and slide the flat end through the locking end and draw it through until all slack is removed. Confirm that the strap is securely laced and locked.

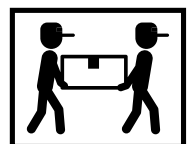
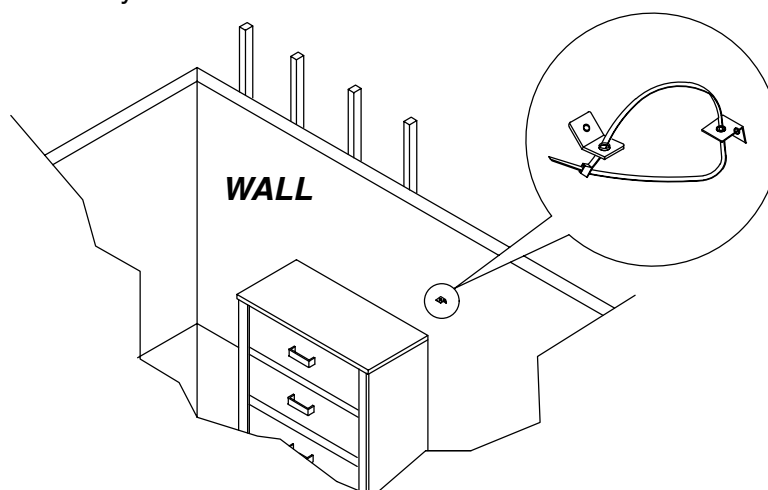

ITEM: **223525**



Inner Size of Drawer A : 34.00"W X 12.75"D X 2.50"H X 0.25"T

Inner Size of Drawer B : 34.00"W X 12.75"D X 5.00"H X 0.25"T

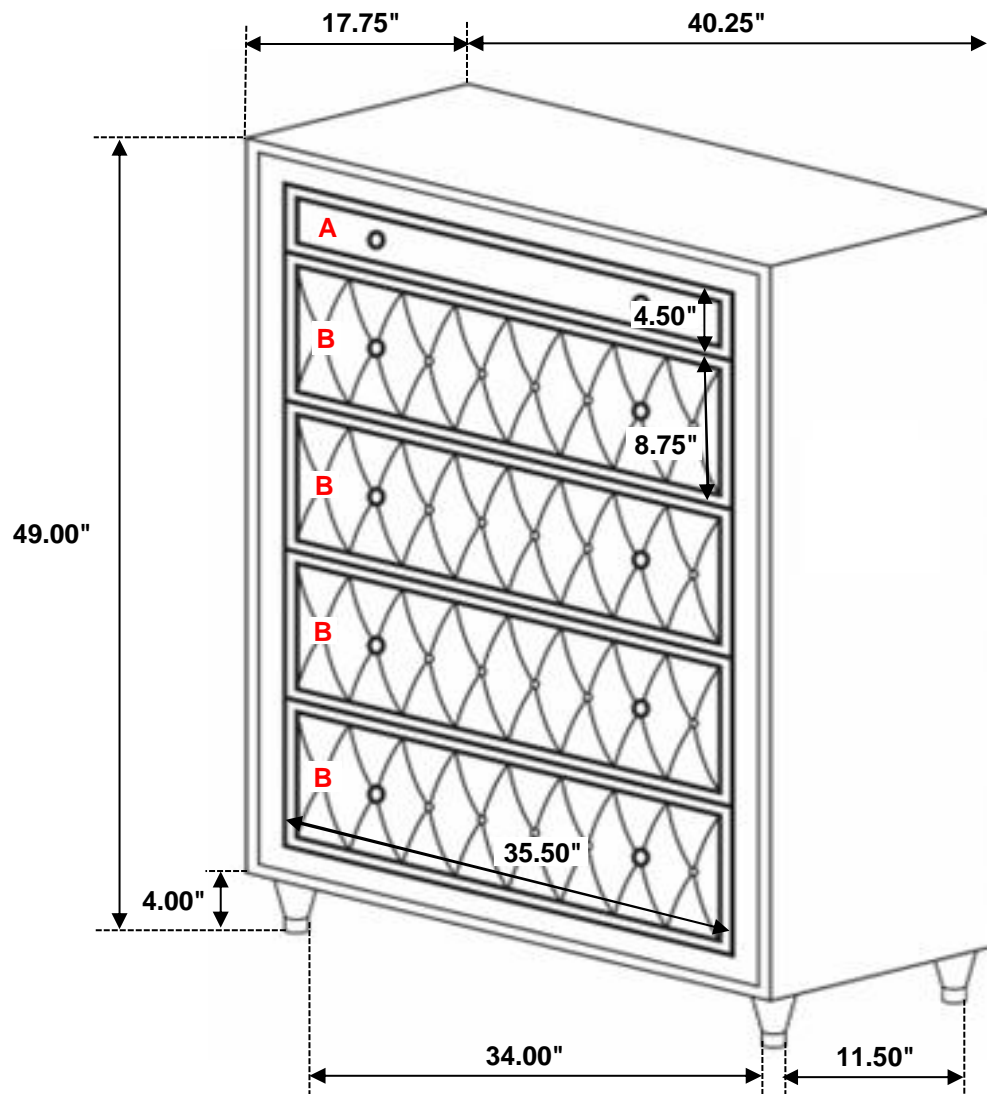

Note : Dimension tolerance  $\pm 5\%$