











Assembly Instructions

Caution : You must read this before you proceed

Care & Maintenance

- ⊘  ● Not for commercial use. For residential use only.
- ⊘  ● Prolonged exposure to rain may cause rusting which can stain floors.
- ⊘  ● Do not put hot items directly on furniture surface.
- ⊘  ● Do not clean furniture with harsh cleansers or polish.
- ✓  ● To obtain the longest lifespan of your outdoor products, minimizing exposure to direct sunlight is recommended.
- ⊘  ● Children should not climb or jump on the furniture.
- ⊘  ● Do not write on furniture without a padded barrier to protect the surface.
- ✓  ● To obtain the longest lifespan of your outdoor products, avoid extended and lengthy exposure to rain, snow, and direct sunshine. Whenever possible cover the product and /or place under patio or awnings.
- ⊘  ● Stains may be removed with mild soap solution and damp cloth.
- ✓  ● Keep away from sources of ignition.
- ✓  ● Dust and pick-up spills using a clean, non-colored, lint-free cloth.

Please look into the Seat Panel for hardware packs

BENCH

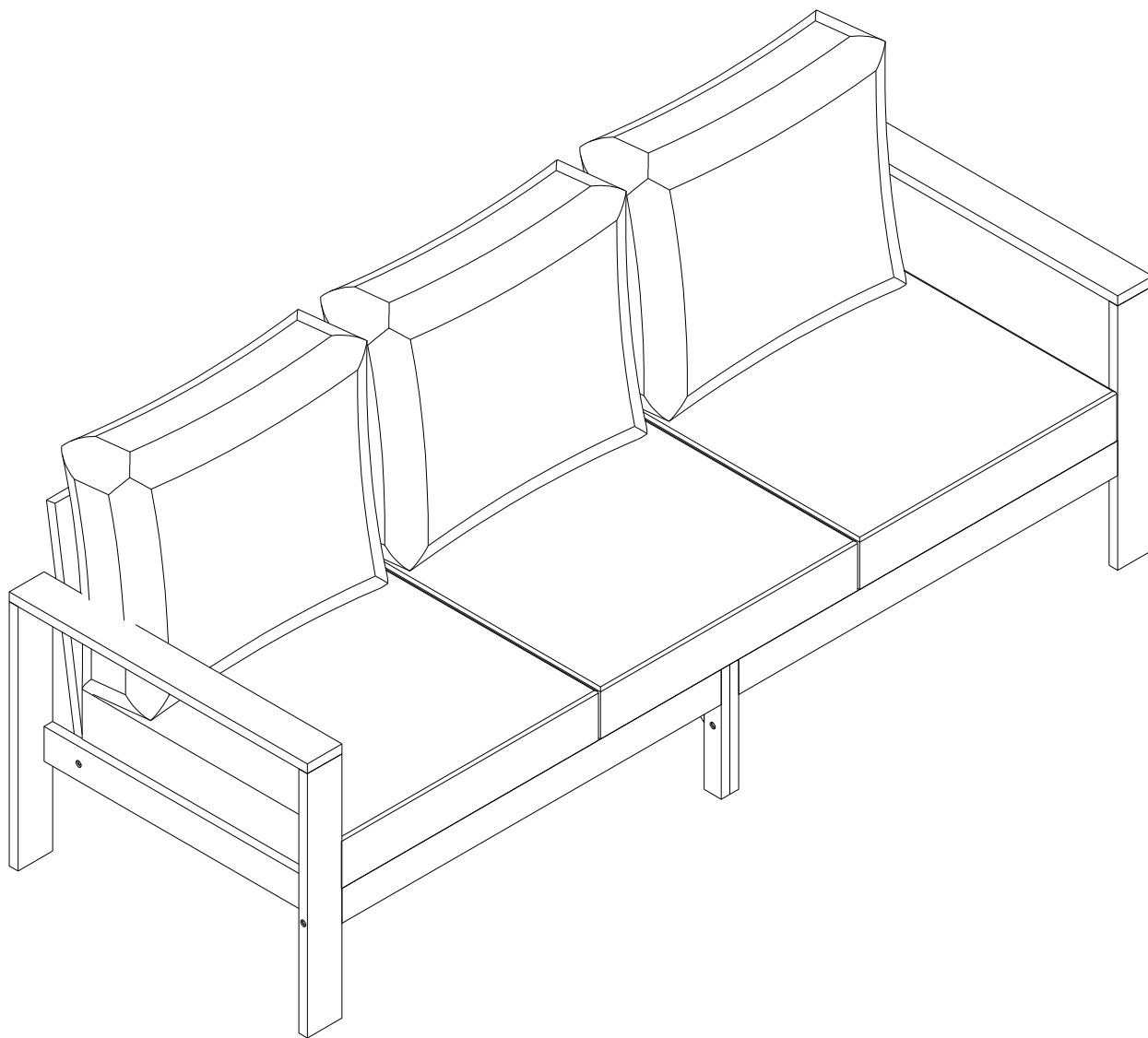

Caution: This Bench is NOT a TOY.

Keep your child/children at bay during the assembly process.

For turning the Bench and to prevent damage to the Bench , 02 persons may be needed to execute this action.



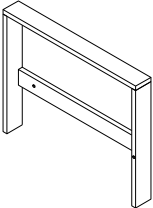
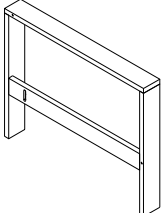
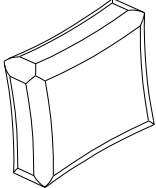
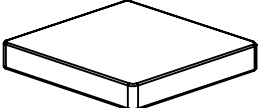
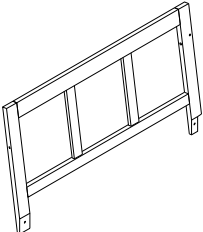
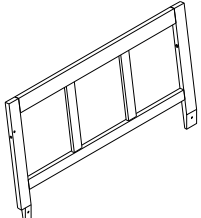
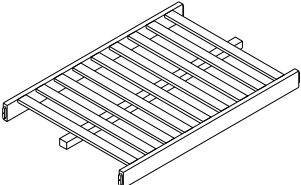
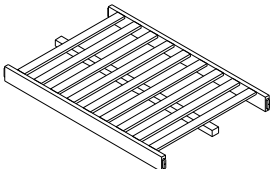
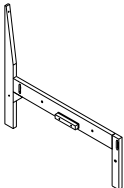

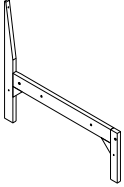

Parts List

Label	Picture	Description	QTY
B		Left Leg Panel	1
C		Right Leg Panel	1
E		Back Cushion	3
F		Seat Cushion	3
G		Left Backrest Panel	1
H		Right Backrest Panel	1
I		Left Seat Panel	1
J		Right Seat Panel	1
K		Left Support Leg	1

Parts List

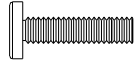
Label	Picture	Description	QTY
L		Right Support Leg	1

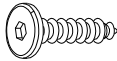





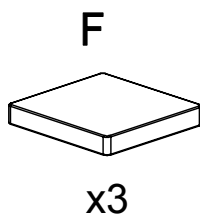
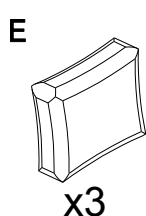
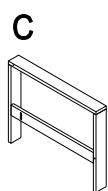
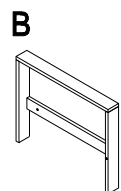

Hardware List

Label	Picture	Description	QTY
①		Screw (M6x110)	3
②		Screw (M6x50)	7
③		Bolt (M6x70)	3
④		Bolt (M6x30)	5
⑤		Allen Wrench (M4)	2
⑥		Bolt (M6x90)	2
⑦		Screw (M6x25)	3
⑧		Sleeve Nut (M6x15)	6
⑨		Bolt (M6x35)	5

Assembly Preparation

Before Beginning Assembly



- ①  x 3 ⑧  x 6
 ②  x 7 ⑨  x 5
 ③  x 3
 ④  x 5
 ⑤  x 2
 ⑥  x 2
 ⑦  x 3

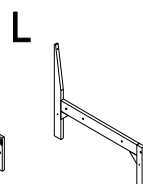
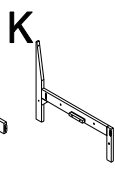
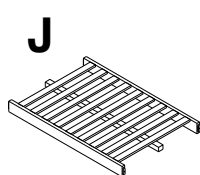
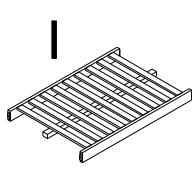
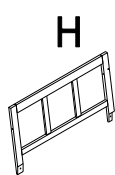
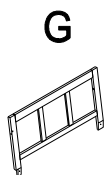



- Read instructions, cover to cover.



- Have 2 adults on hand for assembly.



- Do not assemble on flooring or carpet.



- Assemble on a clean non-marring surface (packing foam).



- Save all packaging until finished.

Assembly Preparation

Overview

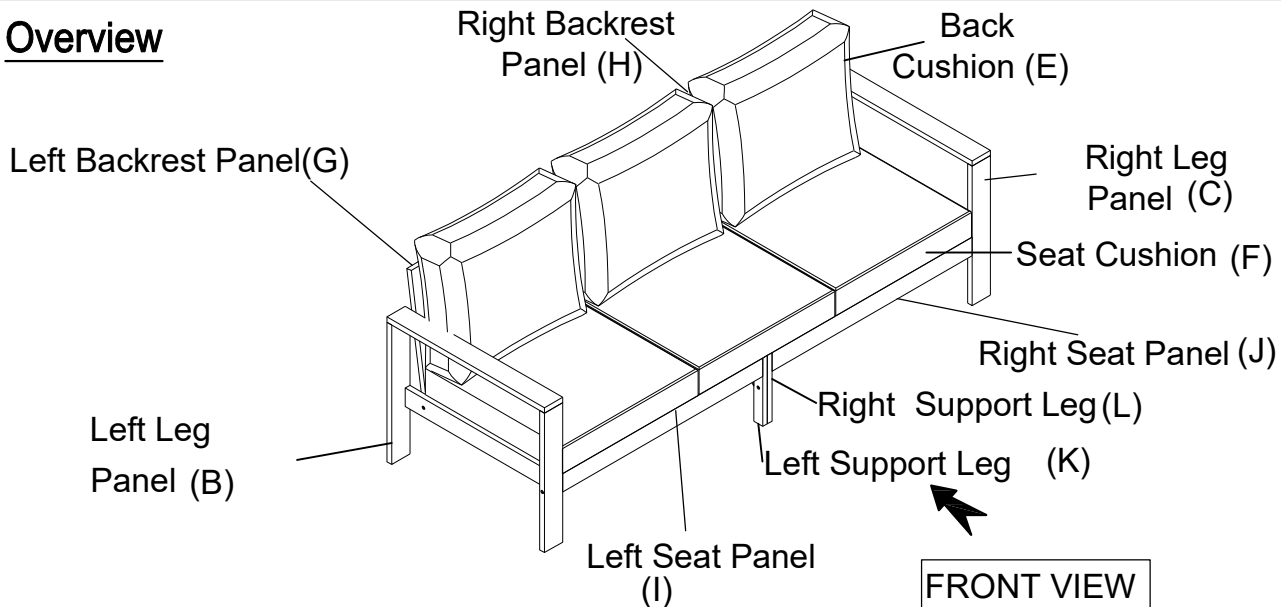

This Bench has multiple parts and may require up to some 30 minutes to assemble. To give you an overview of the Bench, the above picture is to help you put the various parts into perspective. Please read through the instructions here below to familiarise the parts and steps before assembly.

Step 1

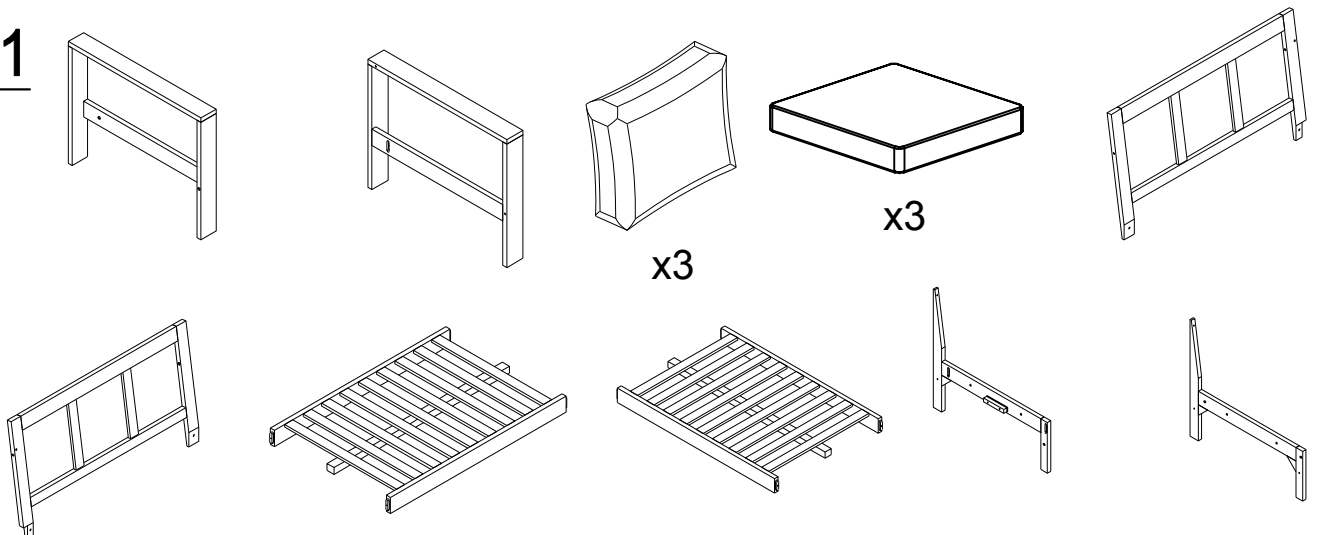

Step 2

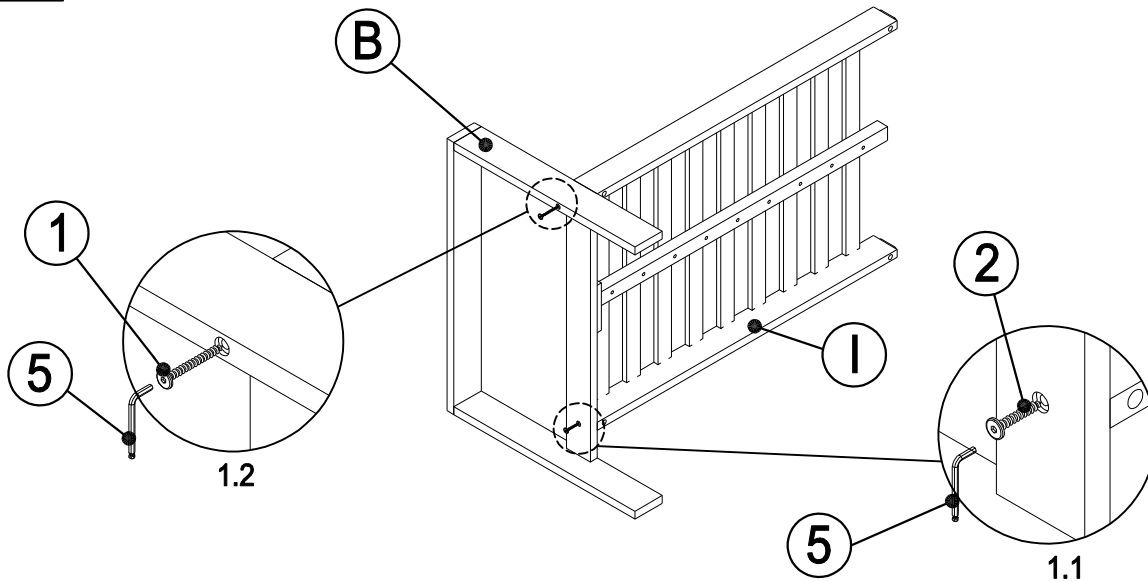

With assistance from your adult partner, place the Left Seat Panel (I) onto a clean, non marring surface, Panels then

1.1 : secure Left Leg Panel (B) by using Screws (2) and Allen Wrench (5).

1.2 : secure Left Leg Panel (B) by using Screws (1) and Allen Wrench (5).

DO NOT fully tighten the Screws.

Step 3

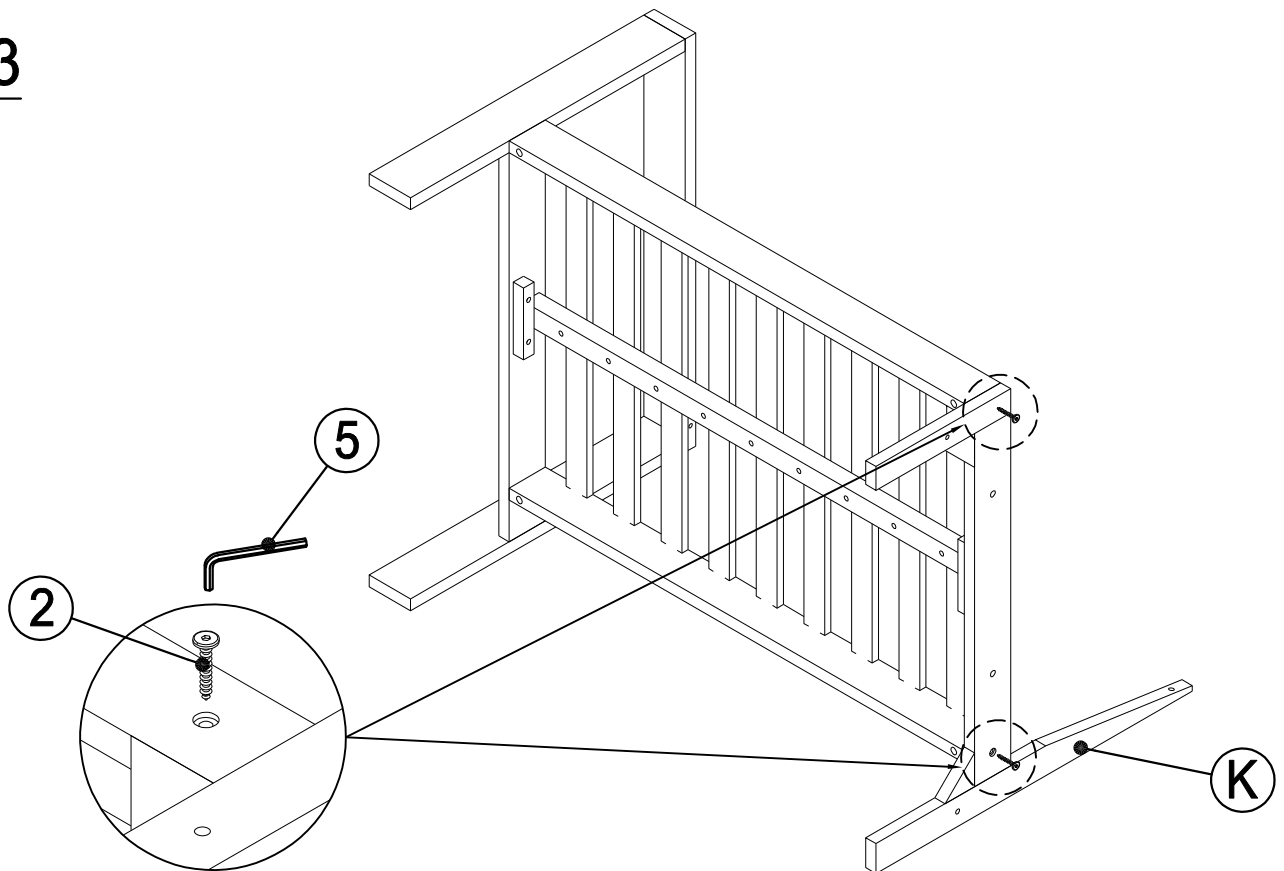

With assistance from your adult partner, attach the Left Support Leg (K) to Left Seat Panel (I) by using Screws (2) with Allen Wrench (5)

Do not fully tighten the Screws.

Step 4

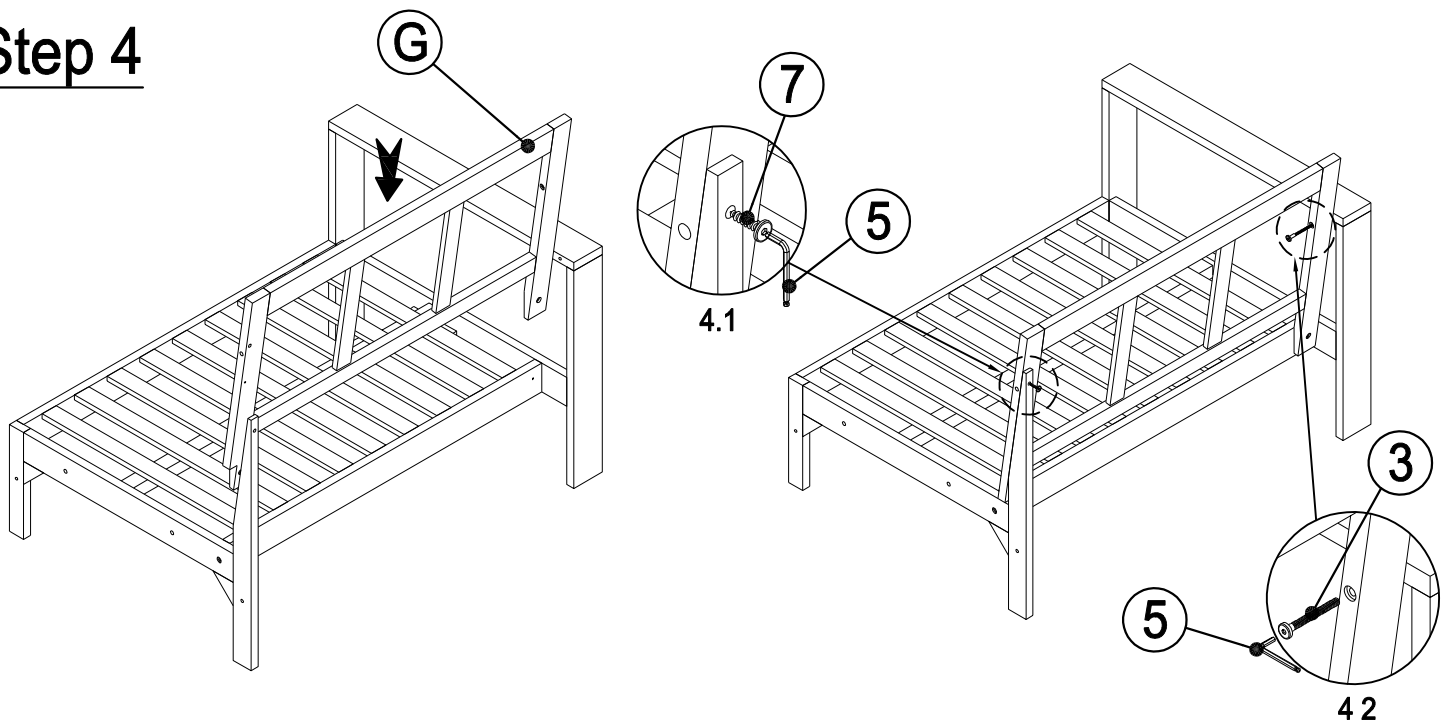

Attach the Left Backrest Panel (G) to Left Leg Panel (B) and Left Support Leg (K)

Panels then:

4.1 : secure Left Backrest Panel (G) by using Screws (7) with Allen Wrench (5)

4.2 : secure Left Backrest Panel (G) by using Bolts (3) with Allen Wrench (5)

Do not fully tighten the Screws and Bolts.

Step 5

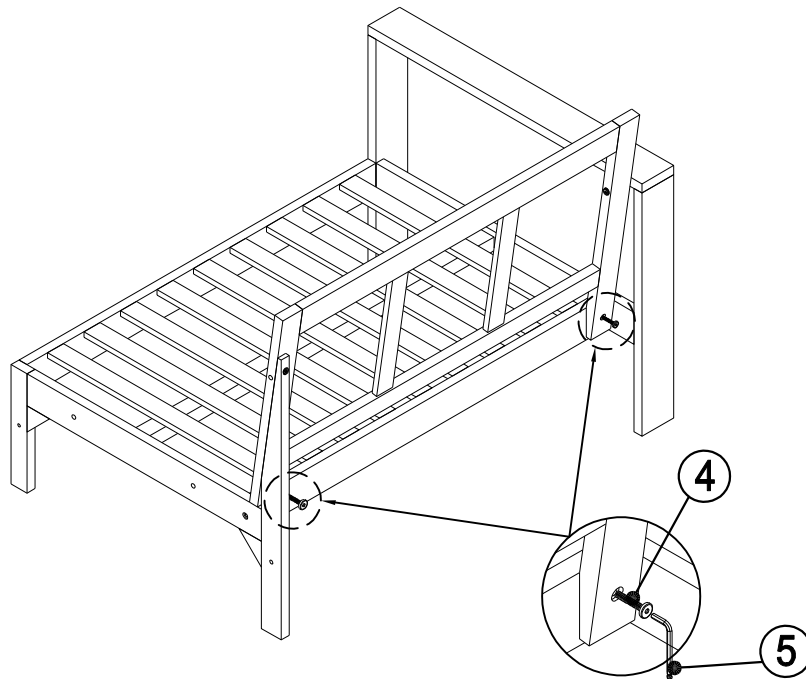

Attach the Left Backrest Panel (G) to Left Seat Panel (I) by using Bolts (4) with Allen Wrench (5).

Do not fully tighten the Bolts.

Step 6

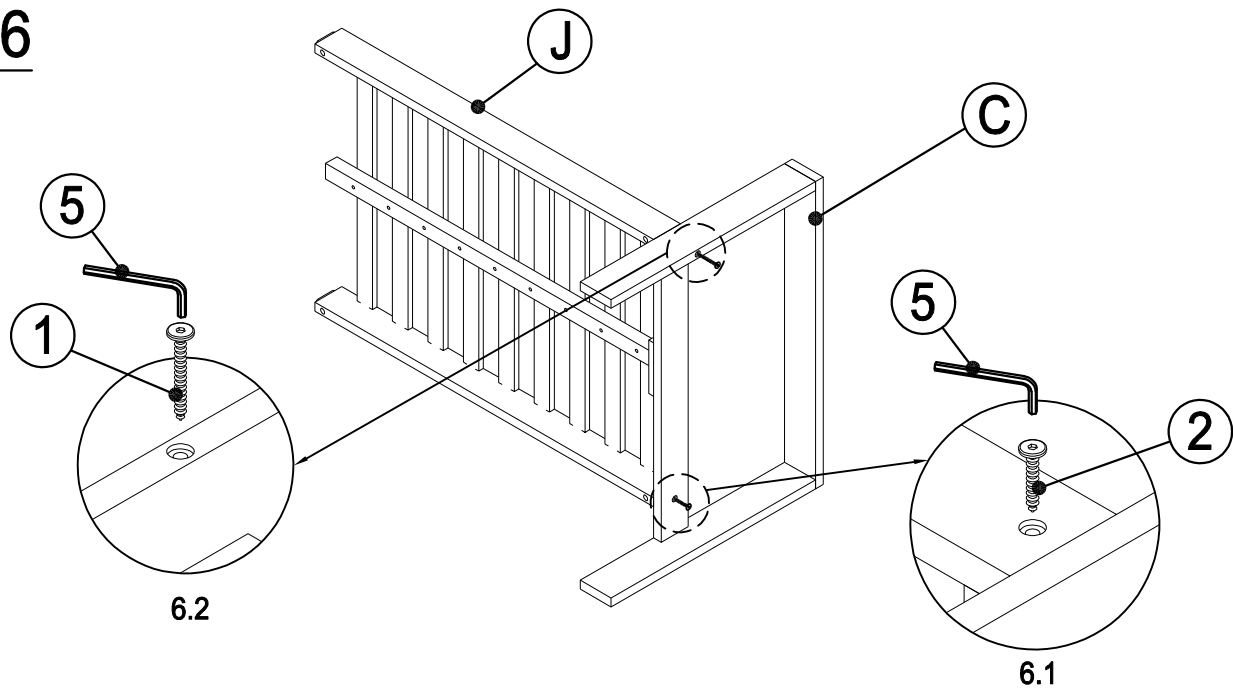

Place the Right Seat Panel (J) onto a clean, non marring surface,
Panels then

6.1 : secure Right Leg Panel (C) by using Screws (②) and Allen Wrench (⑤).

6.2 : secure Right Leg Panel (C) by using Screws (①) and Allen Wrench (⑤)

DO NOT fully tighten the Screws.

Step 7

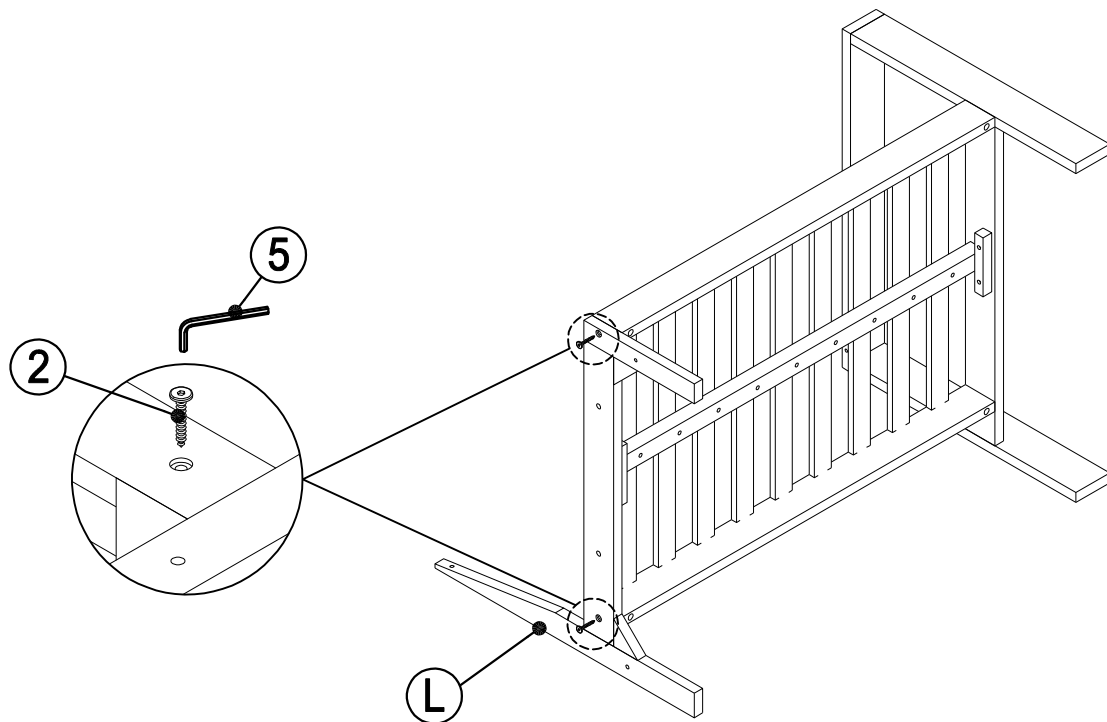

Attach the Right Support Leg(L) to Right Seat Panel (J)by using Screws (②) with
Allen Wrench (⑤).

Do not fully tighten the Screws.

Step 8

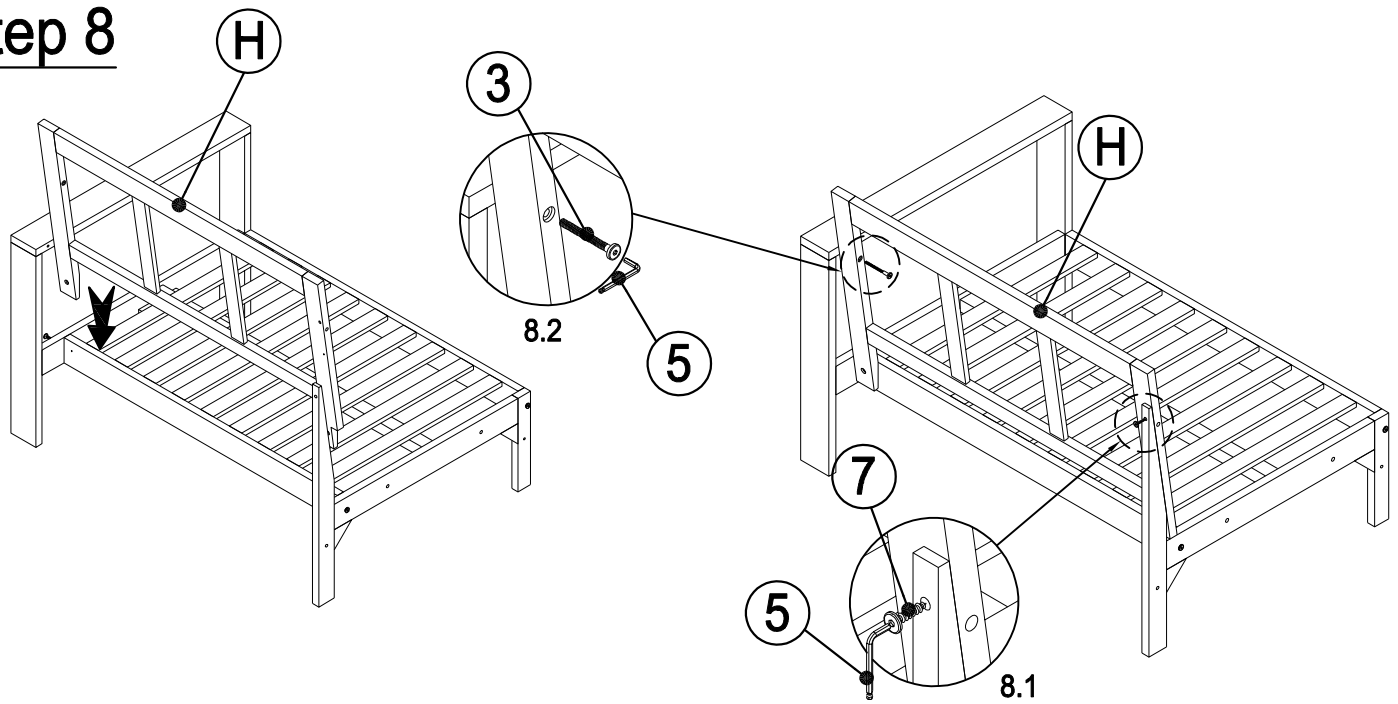

Attach the Right Backrest Panel (H) to Right Leg Panel (C) and Right Support Leg (L) Panels then:

8.1 : secure Right Backrest Panel (H) by using Screws (7) with Allen Wrench (5)

8.2 : secure Right Backrest Panel (H) by using Bolts (3) with Allen Wrench (5)

Do not fully tighten the Screws and Bolts.

Step 9

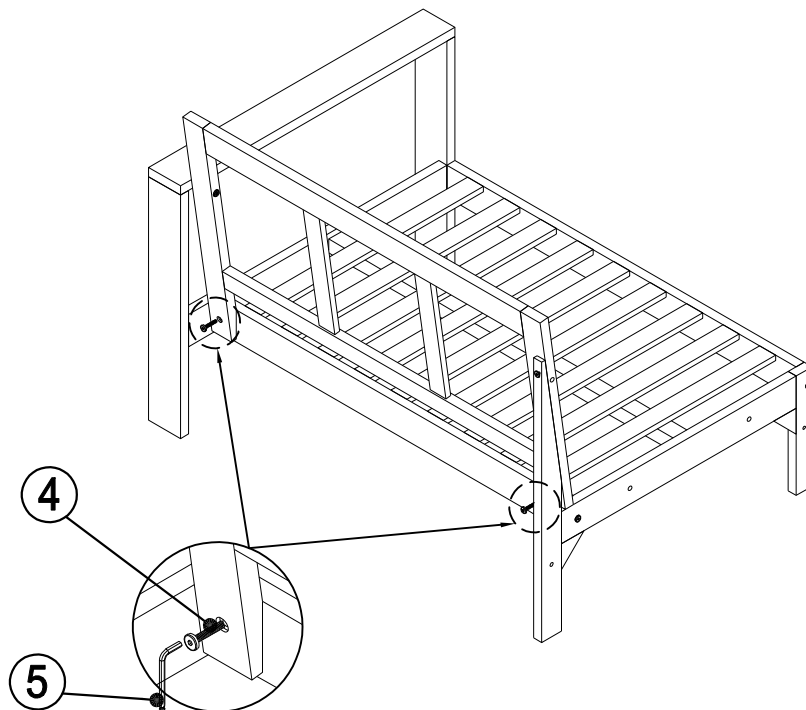

Attach the Right Backrest Panel (H) to Right Seat Panel (I) by using Bolts (4) with Allen Wrench (5).

Do not fully tighten the Bolts.

Step 10

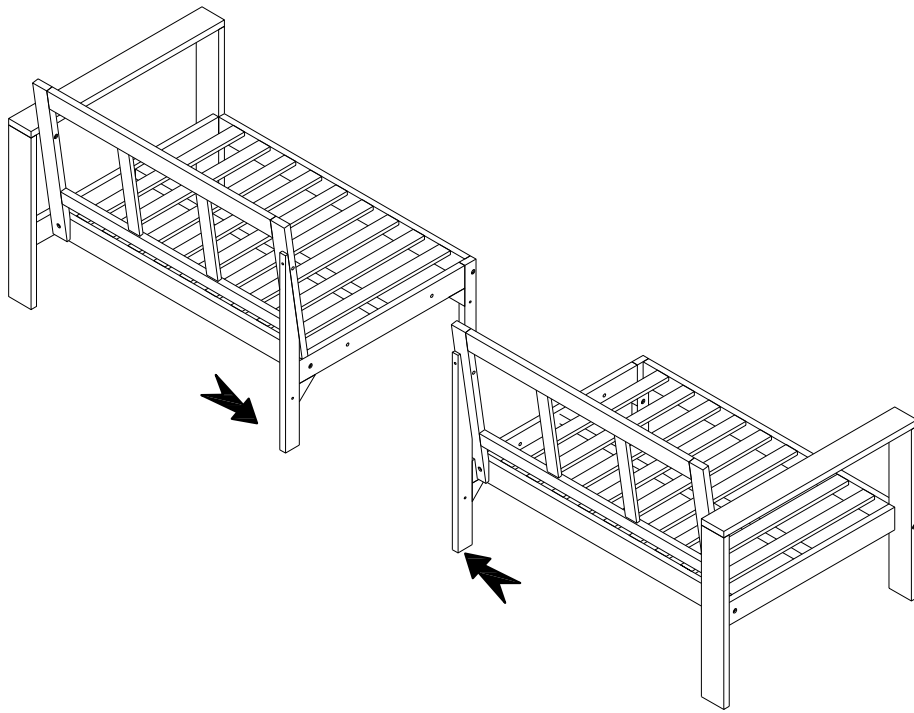

Attach Left Bench together with Right Bench.

Step 11

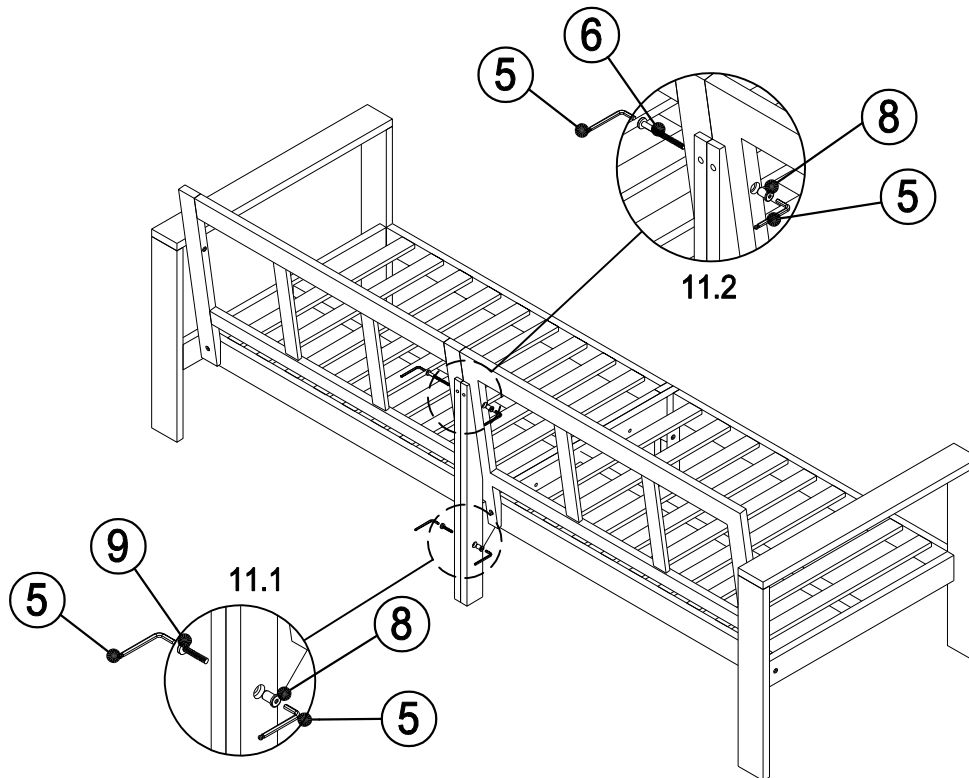

Attach Left Support Leg (K) with Right Support Leg (L).

Panels then:

11.1 : by using Bolts (⑨) Sleeve Nut (⑧) with Allen Wrench (⑤).

11.2 : by using Bolts (⑥) Sleeve Nut (⑧) with Allen Wrench (⑤).

Do not fully tighten the Bolts.

Step 12

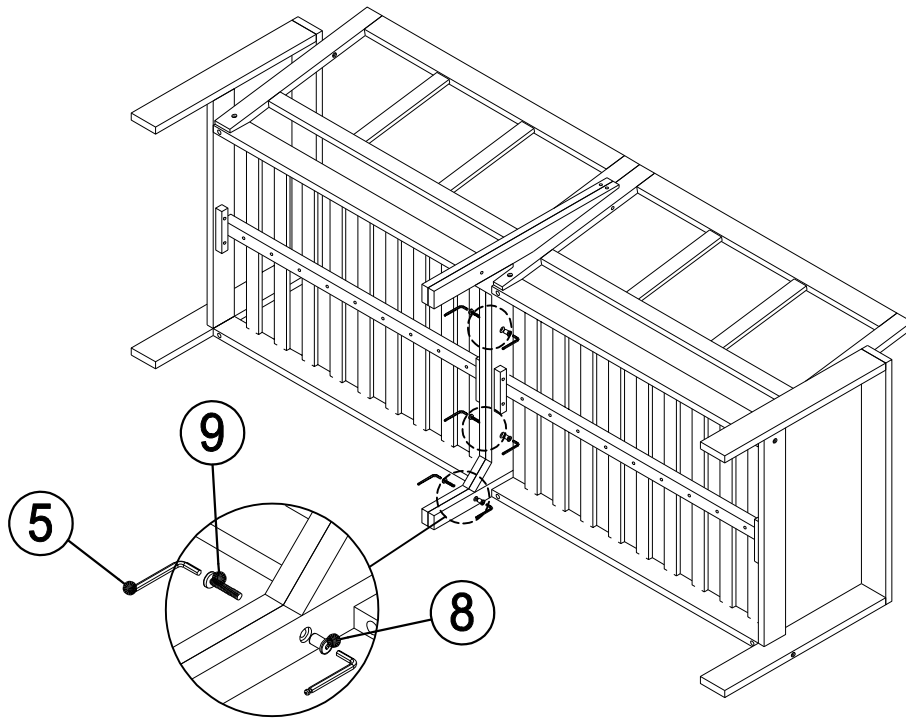

Attach Left Support Leg (K) with Right Support Leg (L) by using Bolts (9) and Sleeve Nut (8) with Allen Wrench (5)

Do not fully tighten the Bolts.

Step 13

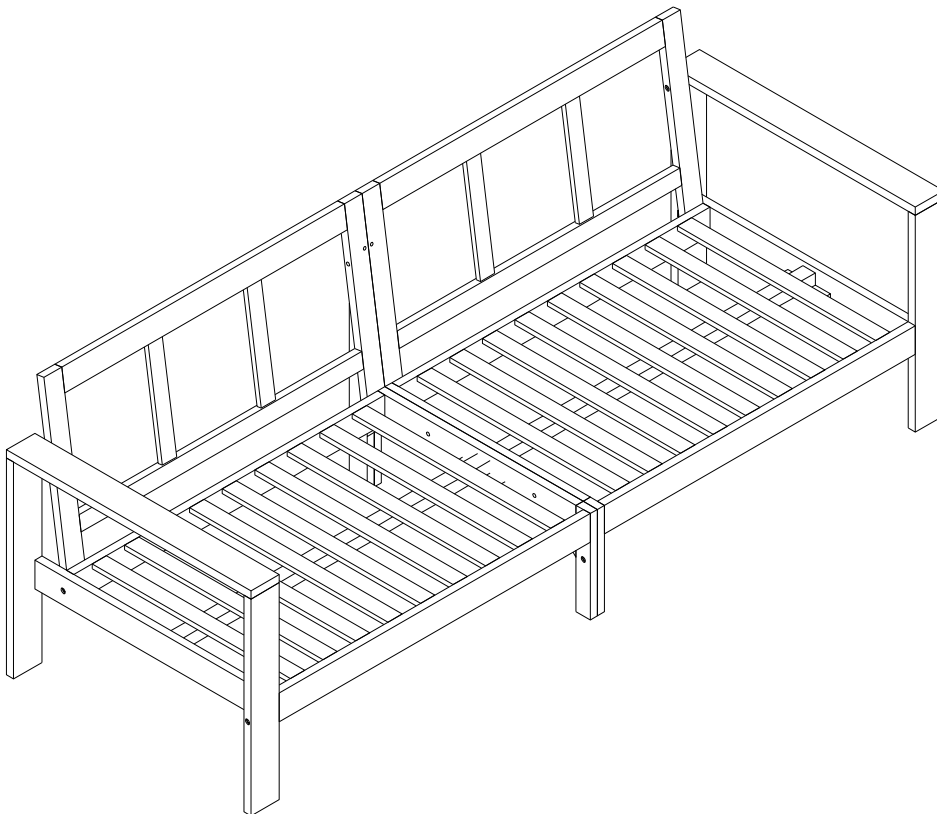

Turn the Bench right side up.
Inspect it and make sure all parts are adequately connected.
Ensure all bolts and screws are fully locked into position and secured.

Step 14

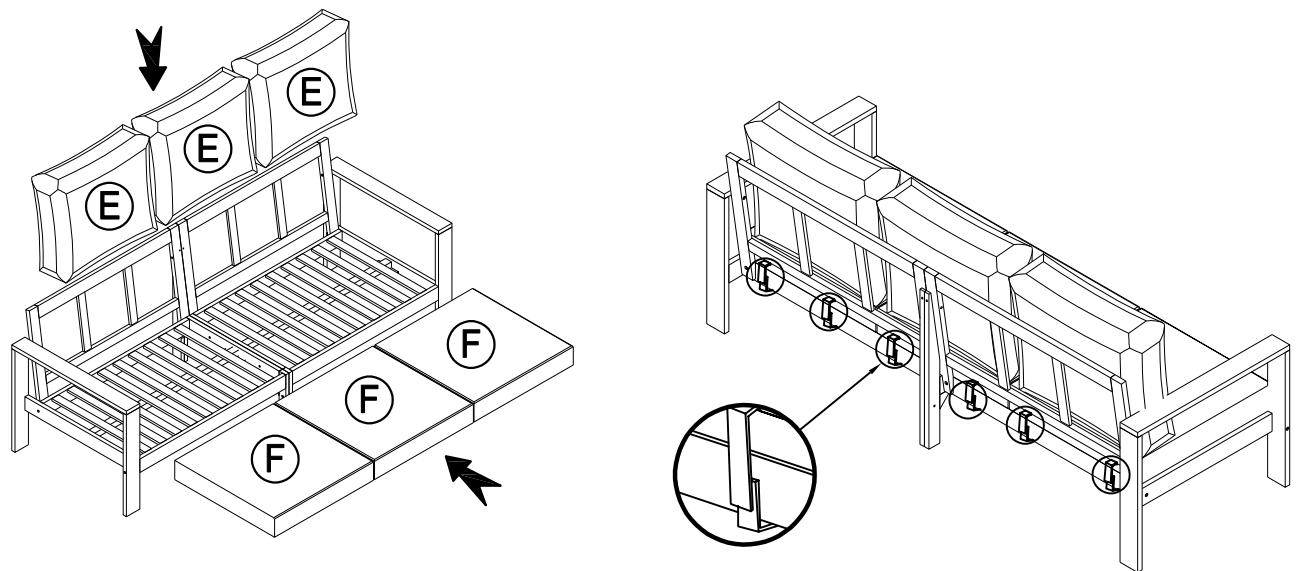

Next, install the Seat Cushion (F) & Back Cushion (E) into the Bench.
Tie the magic tape straps of Seat Cushion (F) and Back Cushions (E) to Left Seat Panel (I) & Right Seat Panel (L) as pictured.
Your Bench is ready for use.
This Bench can only be used on flat, level surface.

Step 15

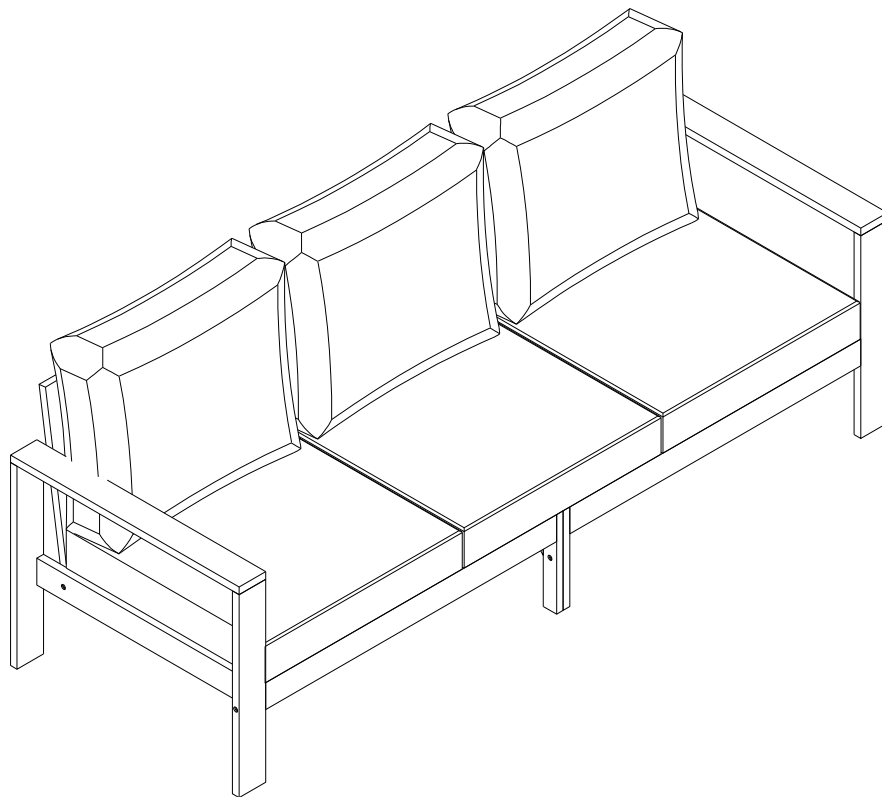

Finish Bench.