

42" DAMITA DOUBLE BOWL FARMER SINK

Cat. No

FSSDB2514-SS



W: 42"

D: 20-3/4"

H: 10"

***Please do NOT cut hole without template or actual product.**

Interior Dimensions:

Large

Basin Interior: 22" W x 16" D

Basin Depth: 9"

Small

Basin Interior: 16" W x 16" D

Basin Depth: 9"

Features:

- ▶ Solid 16 gauge, 304 grade metal construction
- ▶ Tight radius corners
- ▶ Template included
- ▶ Easy maintenance with matte finish
- ▶ Insulated for sound reduction
- ▶ Curved bowl
- ▶ Rim width is 1-1/2"
- ▶ Drain is 3-1/2"
- ▶ 60/40 offset
- ▶ Wire grid available to purchase separately, **FSSDB2514-Wire**

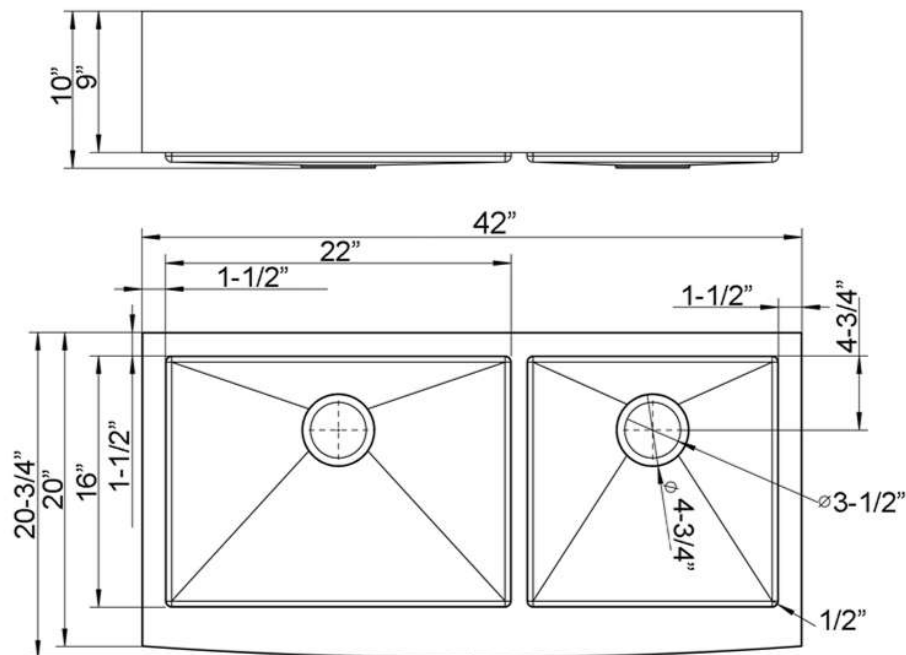

Dimensions of fixture are nominal and may vary within the range of tolerances established by ANSI Standard A112.19.2. Dimensions and specifications subject to change without notice.