

Assembly Instructions

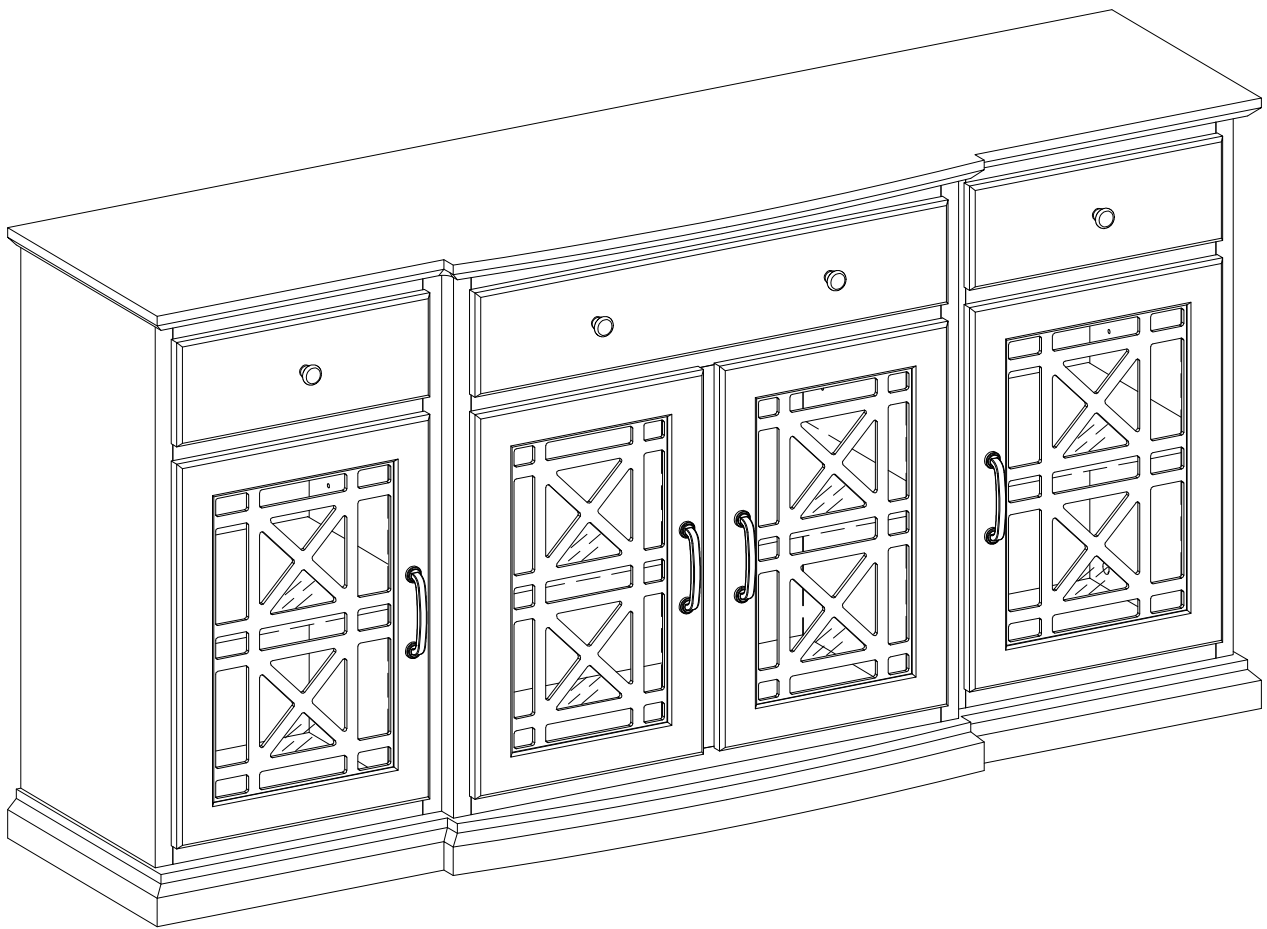

General Assembly Guidelines

- I. Ensure that all parts and hardware are available before beginning assembly.
- II. Follow each step carefully to ensure the proper assembly of this product.
- III. Two people are recommended for ease in the assembly of this product.
- IV. The three main types of hardware used to assemble this product are : wood dowels , screws and bolts.
- V. The provided glue is to secure wood dowels in place . When first inserting dowels , locate the appropriate hole for the dowel , place a small amount of glue in the hole and insert the dowel . Wipe away excess glue immediately.

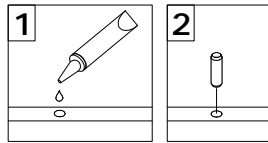

In future assembly steps when dowels are necessary to attach assembly parts together , place a small amount of glue on the end of the dowel before attaching parts together . Wipe away excess glue immediately.

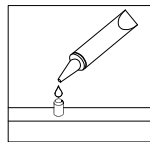

- VI. A Phillips head screwdriver is required for the assembly of this product .

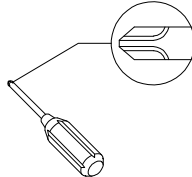

- VII. Power tools should not be used to assemble this product .

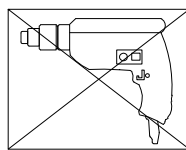

- VIII. Concealed hinges are three-way adjustable.

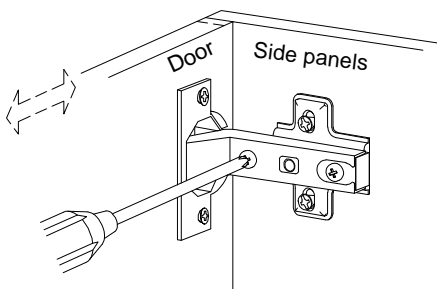

Horizontal
by screw adjustment

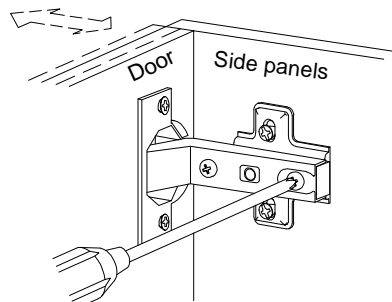

In-and-Out
by loosening the hinge-arm
mounting screw or via cam
adjustment

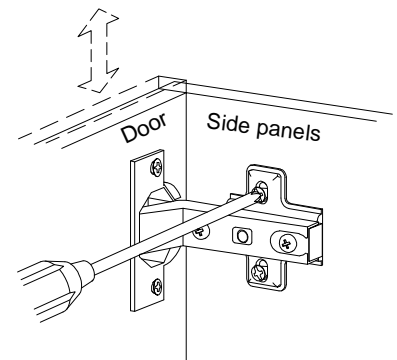





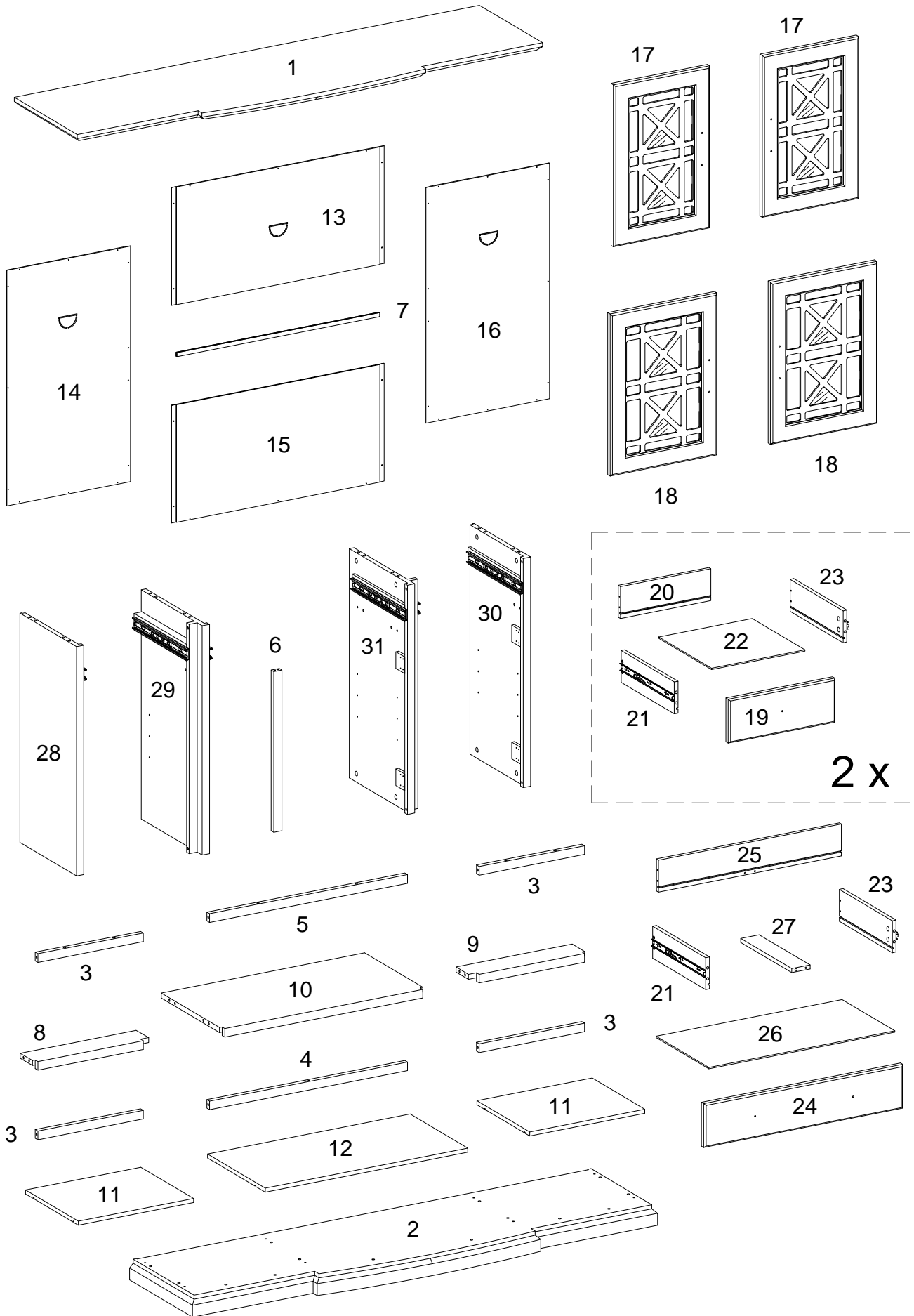





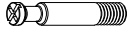







Vertical
Via slots in the mounting
plate or via cam adjustment

Parts List

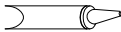

Hardware List

A		Ø6x30mm	Wooden dowel	5	pc
B		Ø8x30mm	Wooden dowel	48	pcs
C		Ø6x32mm	Cam bolt	36	pcs
D		Ø6x35mm	Cam bolt	1	pc
E		Ø15x9.5mm	Cam lock	37	pcs
F			Sticker	37	pcs
G			Shelf support pin	12	pcs
H		Ø4x18mm	Handle Bolt	12	pcs
J			Handle	4	pcs
K			Handle	4	pcs
L		Ø4x25mm	Screw	14	pcs
M			Europe hinge	8	pcs
N		Ø4x12mm	Bolt	48	pcs
P			Screw	32	pcs
Q			Plastic strap	2	pcs
R			Nut	2	pcs
S		Ø4x12mm	Screw	2	pcs
T		Ø4x25mm	Screw	2	pcs
U			Glue tube	1	pc

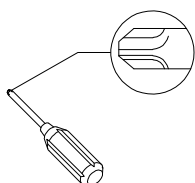

Philips head screwdriver required for assembly
(not included)

*The hardware quantities listed above are required for proper assembly.
Some extra hardware may also have been included.*

Step 1

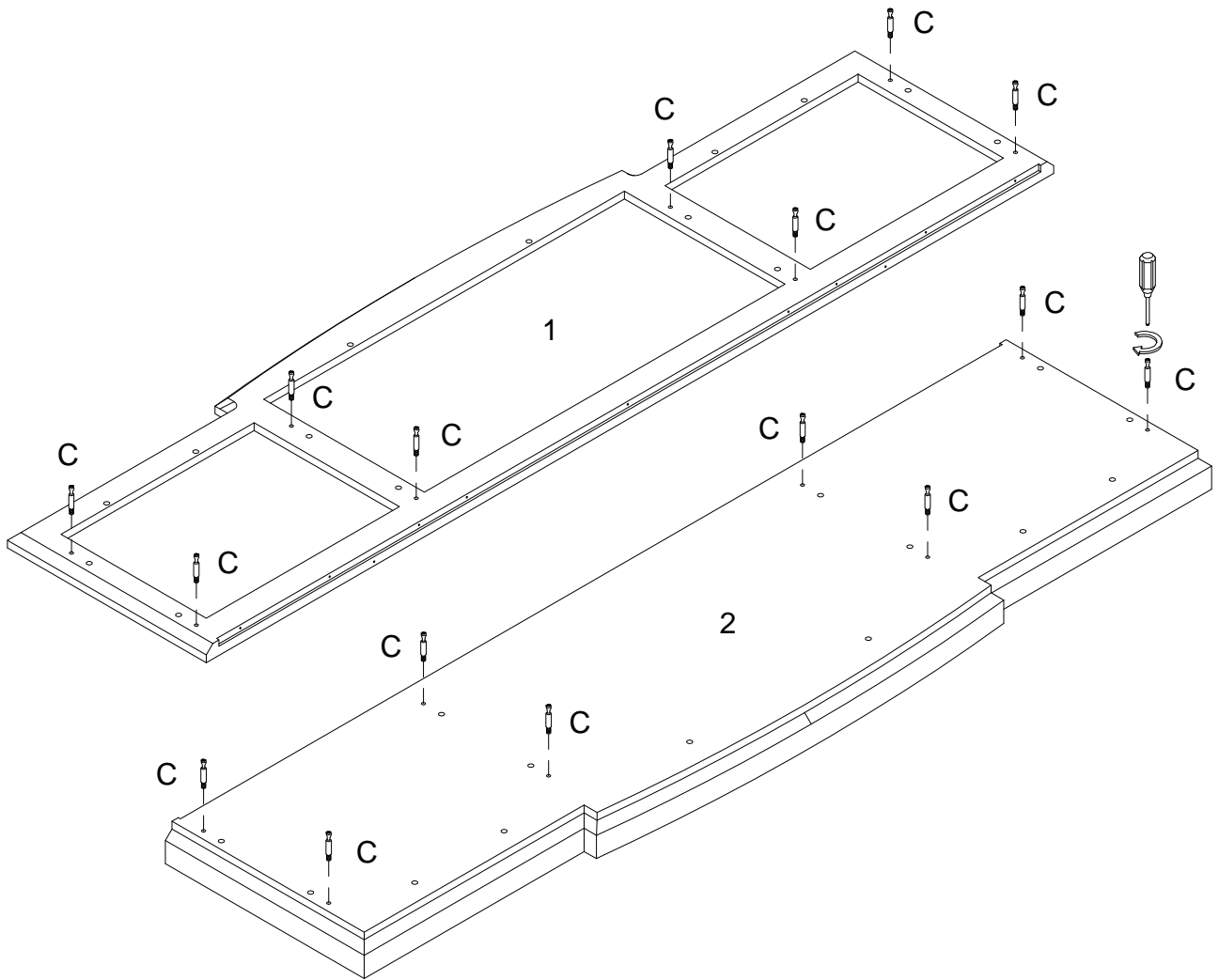

Secure cam bolt (C) into parts (1,2) with Philips head screwdriver as per diagram.

Step 2

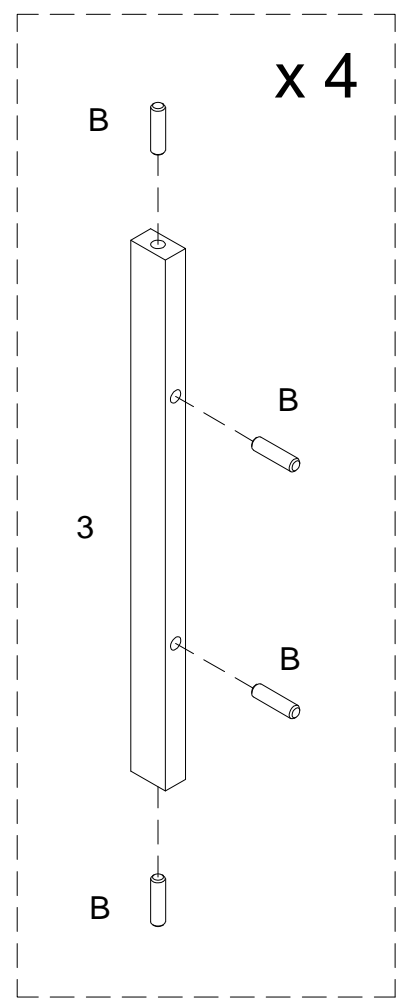
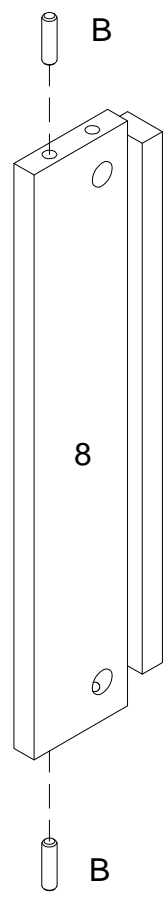
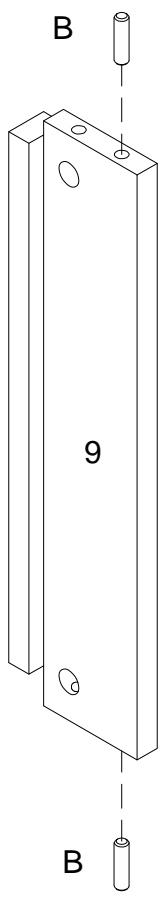

Insert wooden dowel (B) into parts (3,8,9) as per diagram.

Step 3

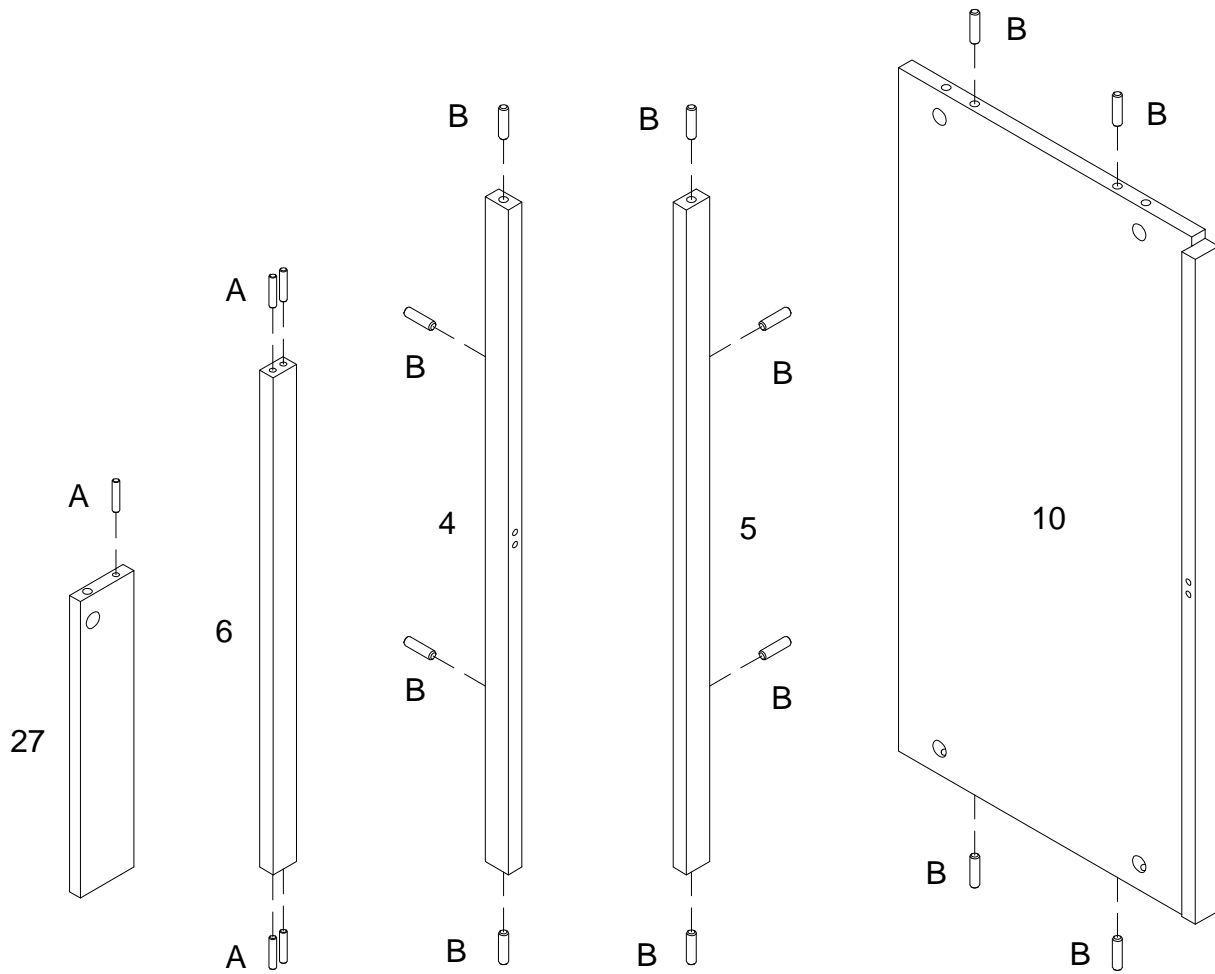

Insert wooden dowel (A) into parts (6,27), wooden dowel (B) into parts (4,5,10) as per diagram.

Step 4

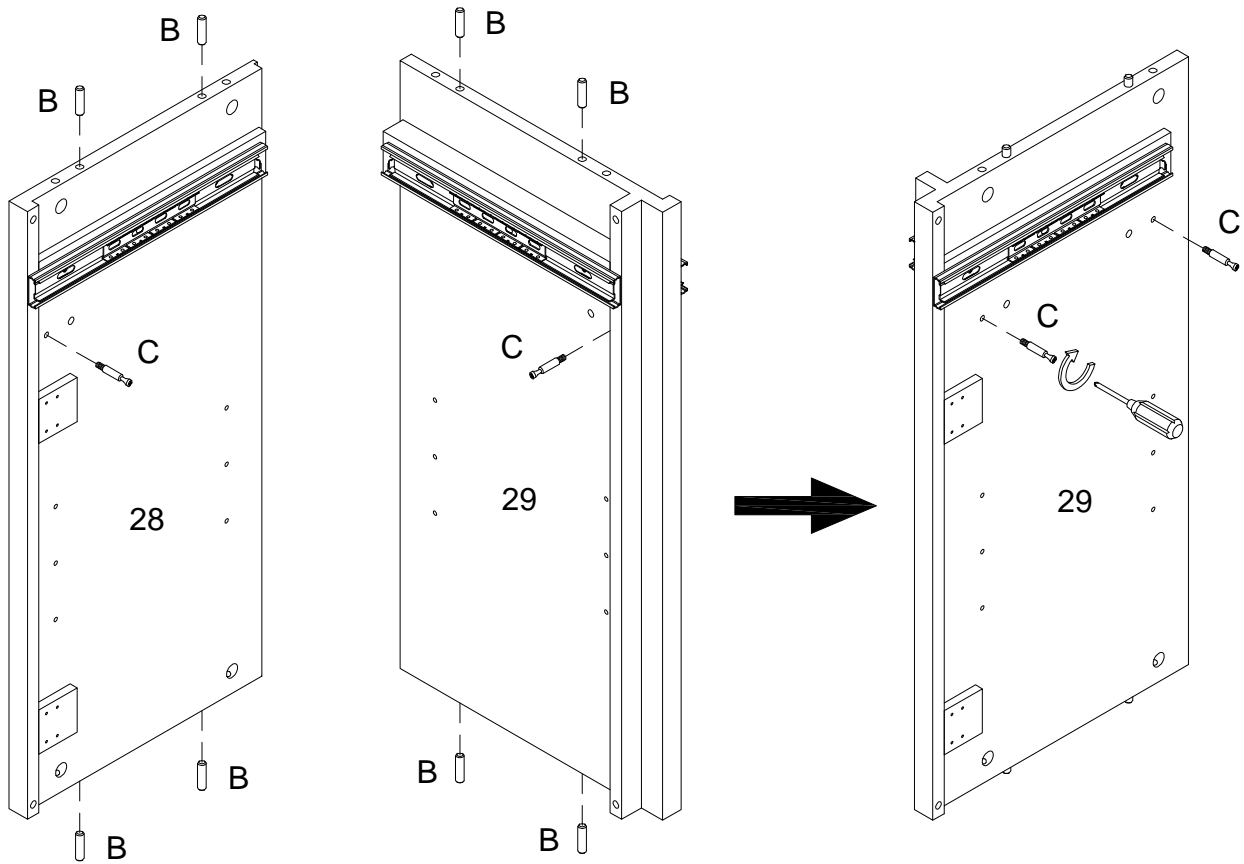

Insert wooden dowel (B) into parts (28,29), then secure cam bolt (C) into parts (28,29) with Philips head screwdriver as per diagram.

Step 5

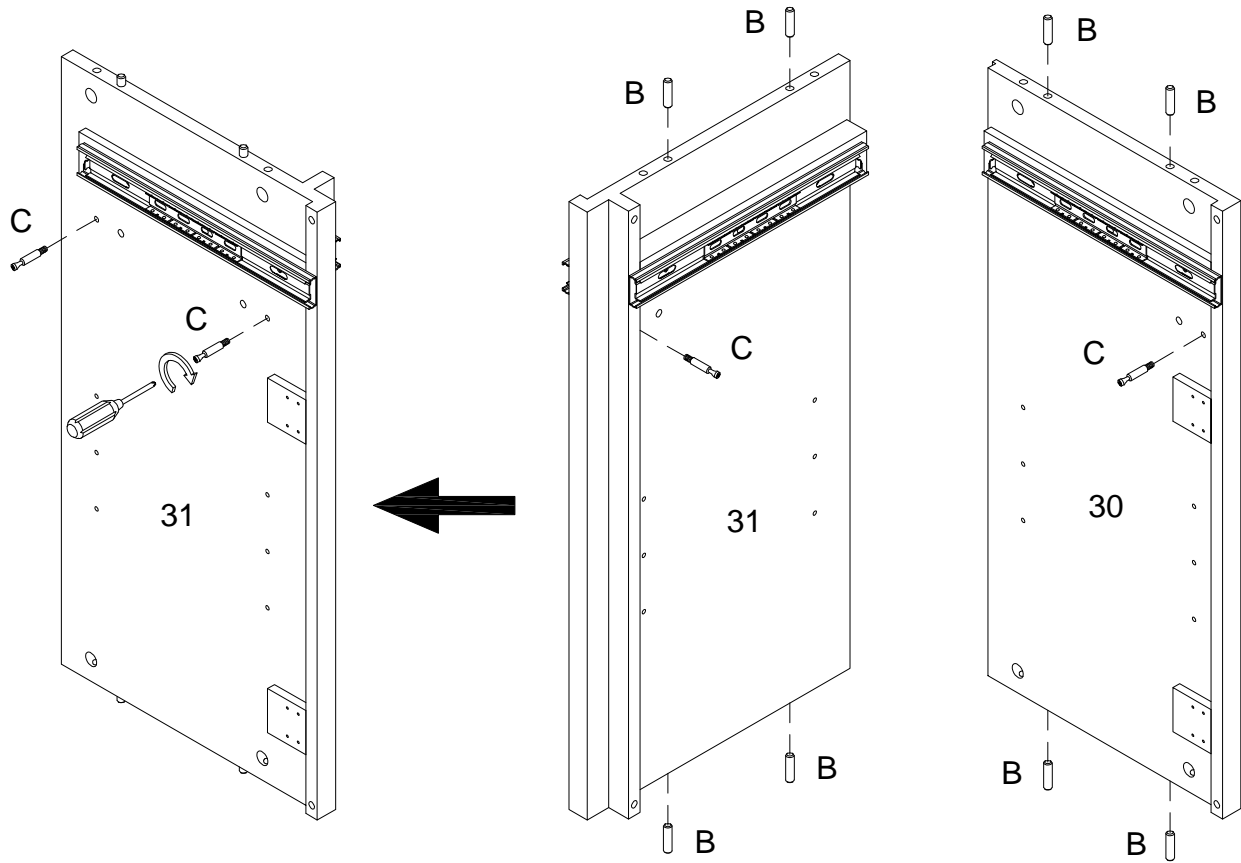

Insert wooden dowel (B) into parts (30,31), then secure cam bolt (C) into parts (30,31) with Philips head screwdriver as per diagram.

Step 6

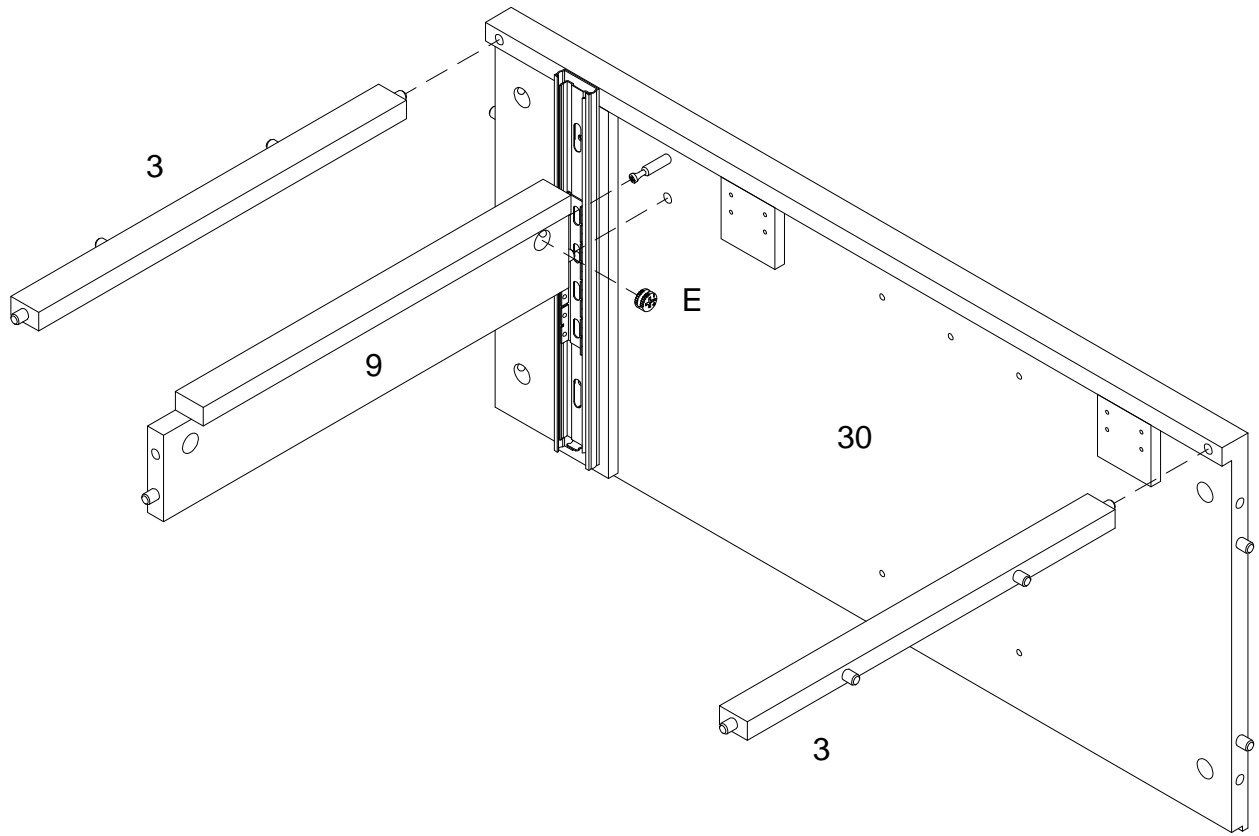
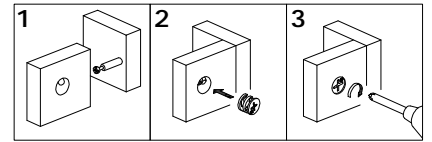

Part (3) attach into part (30) ,then using cam lock (E) secure part (9) to part (30) and with Philips head screwdriver as per diagram.

Step 7

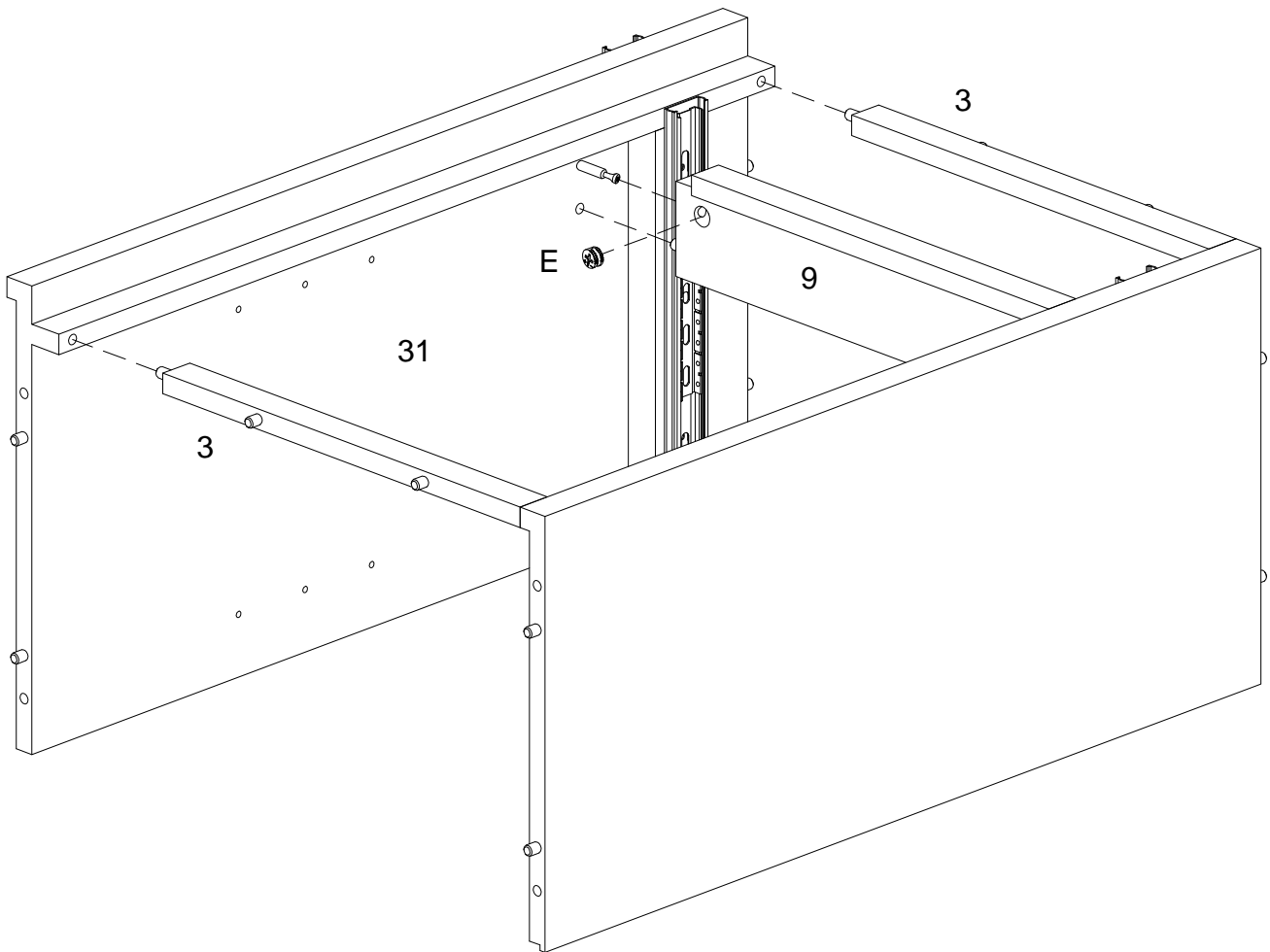
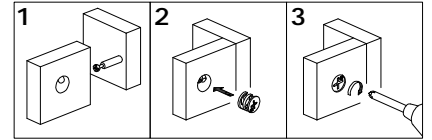

Part (3) attach into part (31) ,then using cam lock (E) secure part (9) to part (31) and with Philips head screwdriver as per diagram.

Step 8

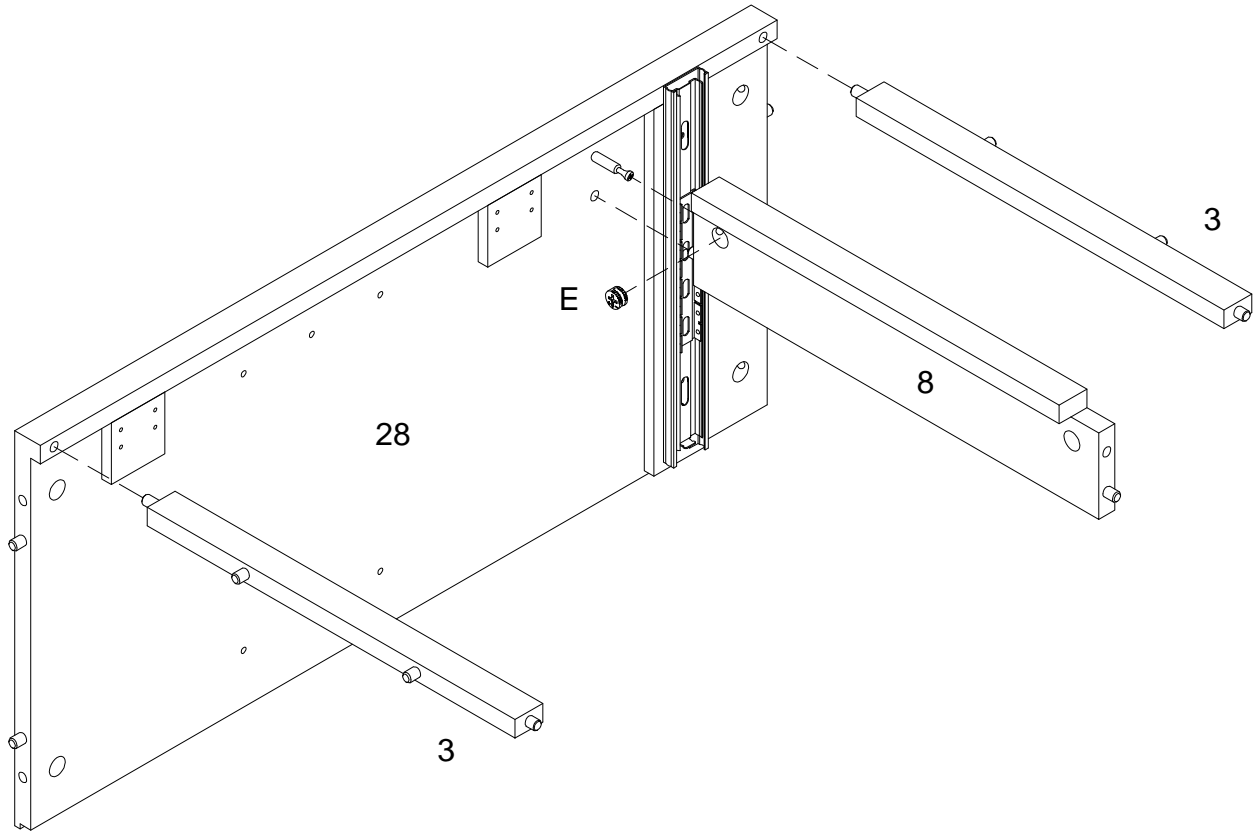
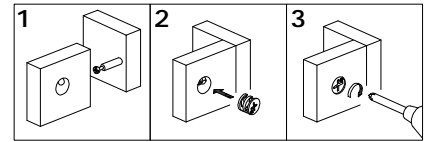

Part (3) attach into part (28) ,then using cam lock (E) secure part (8) to part (28) and with Philips head screwdriver as per diagram.

Step 9

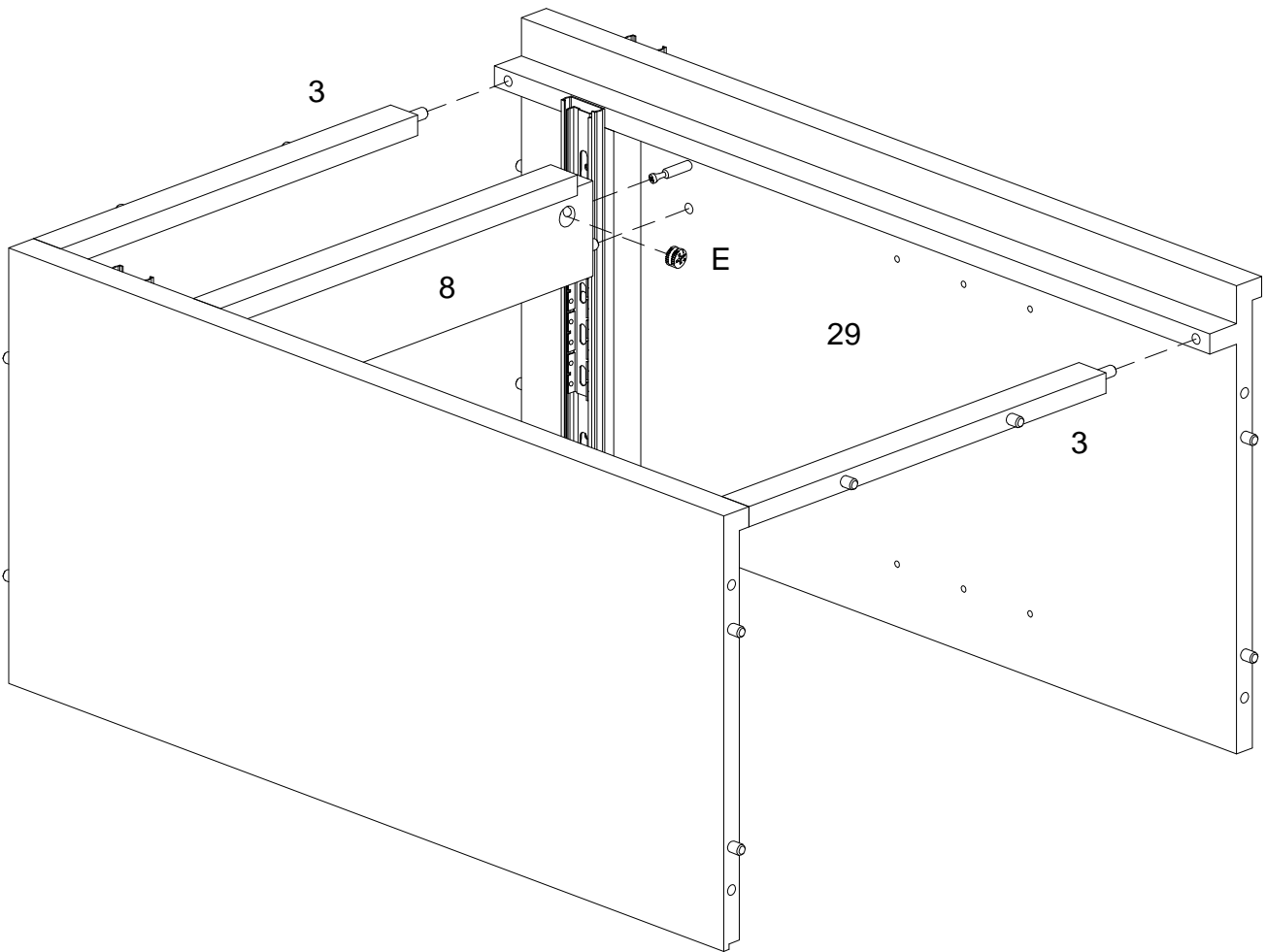
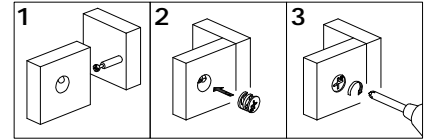

Part (3) attach into part (29) ,then using cam lock (E) secure part (8) to part (29) and with Philips head screwdriver as per diagram.

Step 10

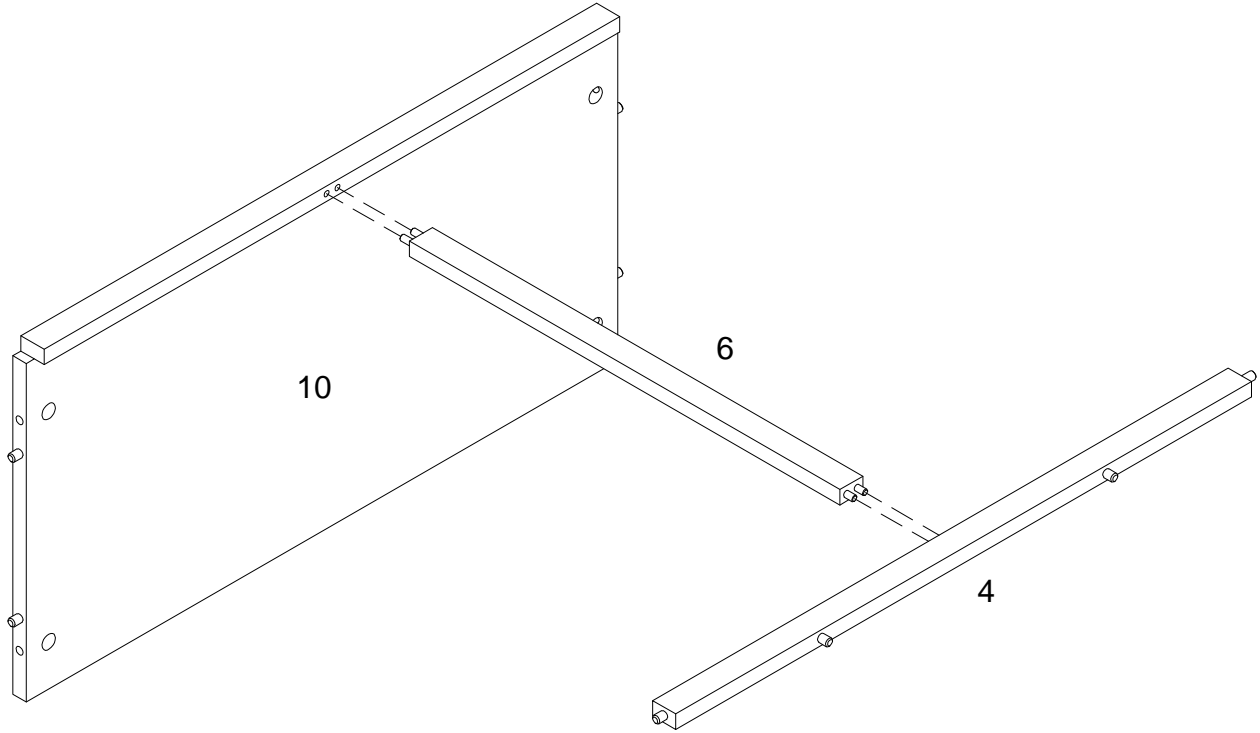

Part (6) insert to parts (4,10) as per diagram.

Step 11

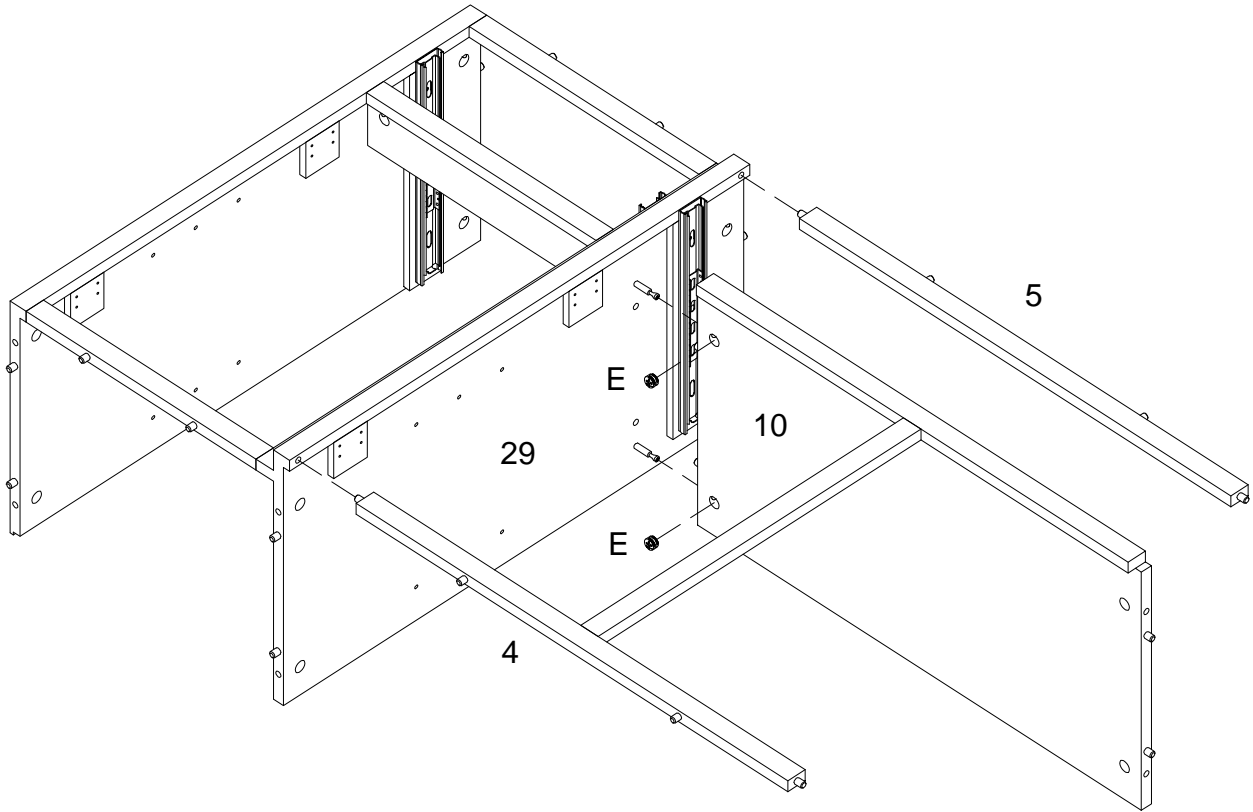
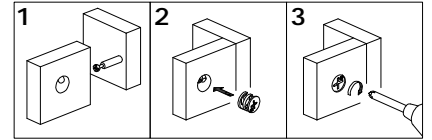

Parts (4,5) attach into part (29) ,then using cam lock (E) secure part (10) to part (29) and with Philips head screwdriver as per diagram.

Step 12

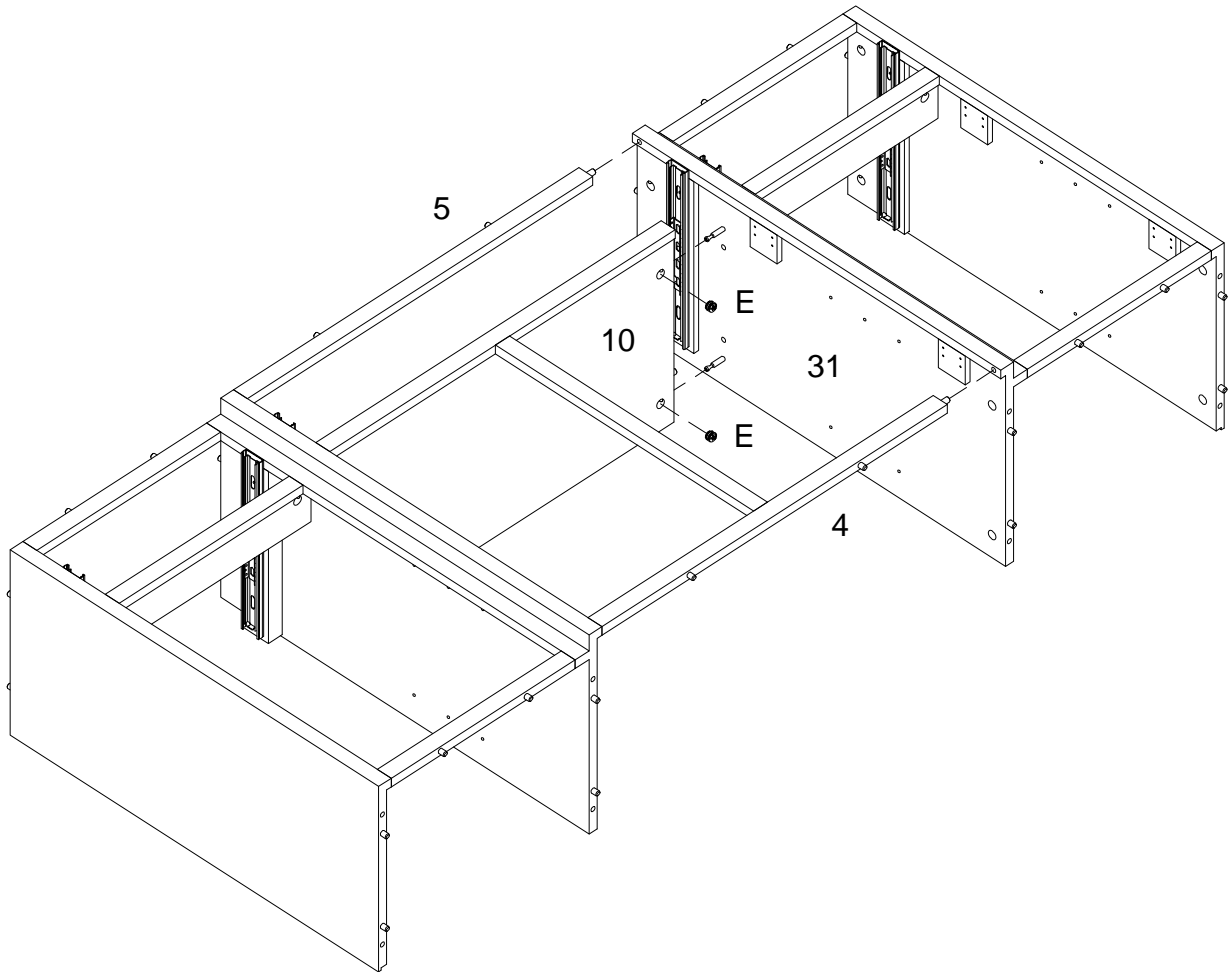
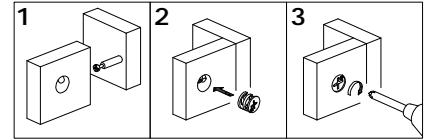

Parts (4,5) attach into part (31) ,then using cam lock (E) secure part (10) to part (31) and with Philips head screwdriver as per diagram.

Step 13

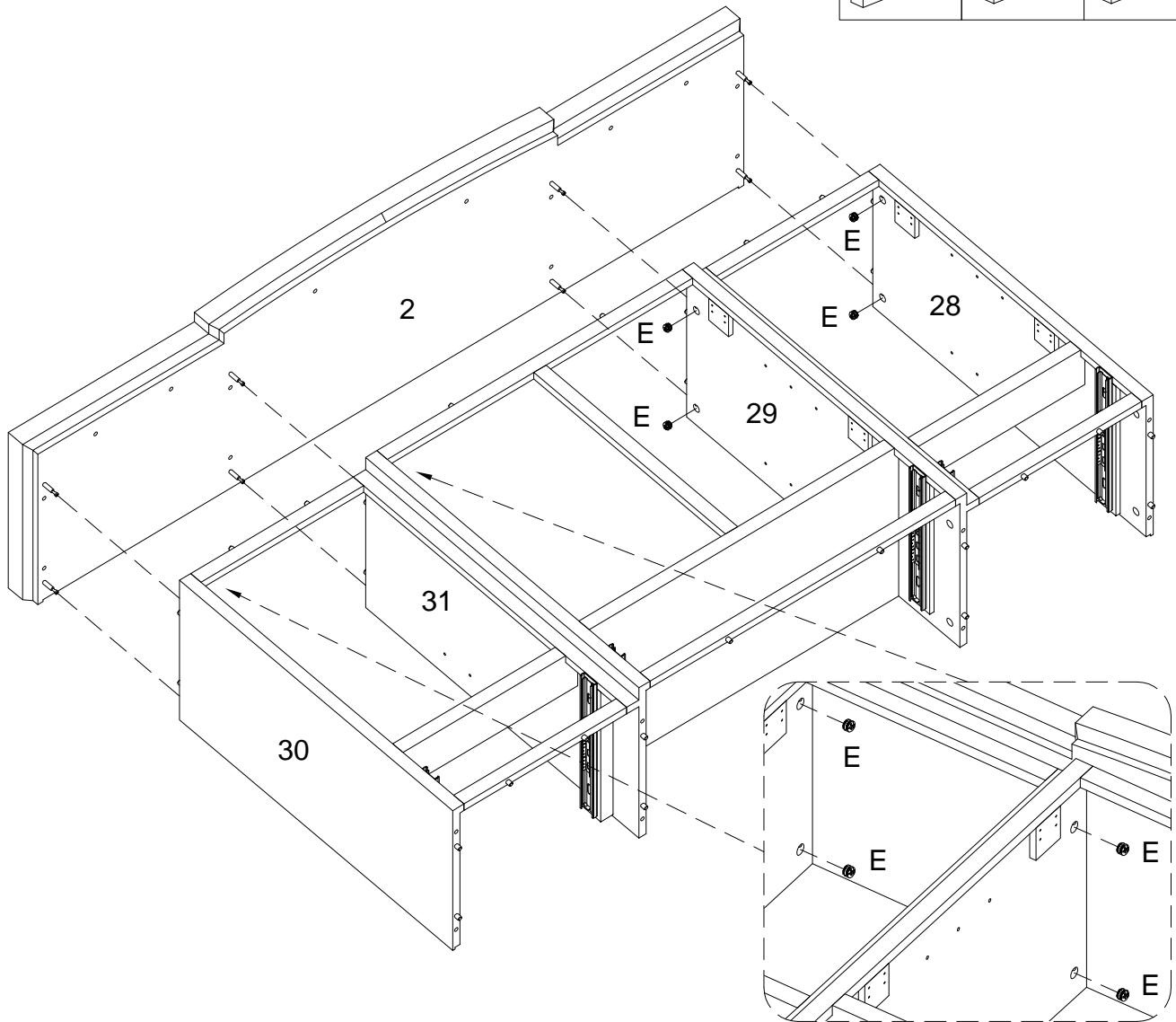
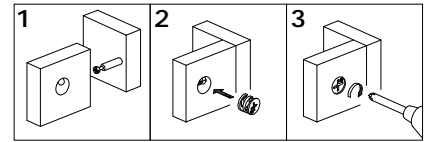

Using cam lock (E) attach part (2) to parts (28,29,30,31) with Philips head screwdriver as per diagram.

Step 14

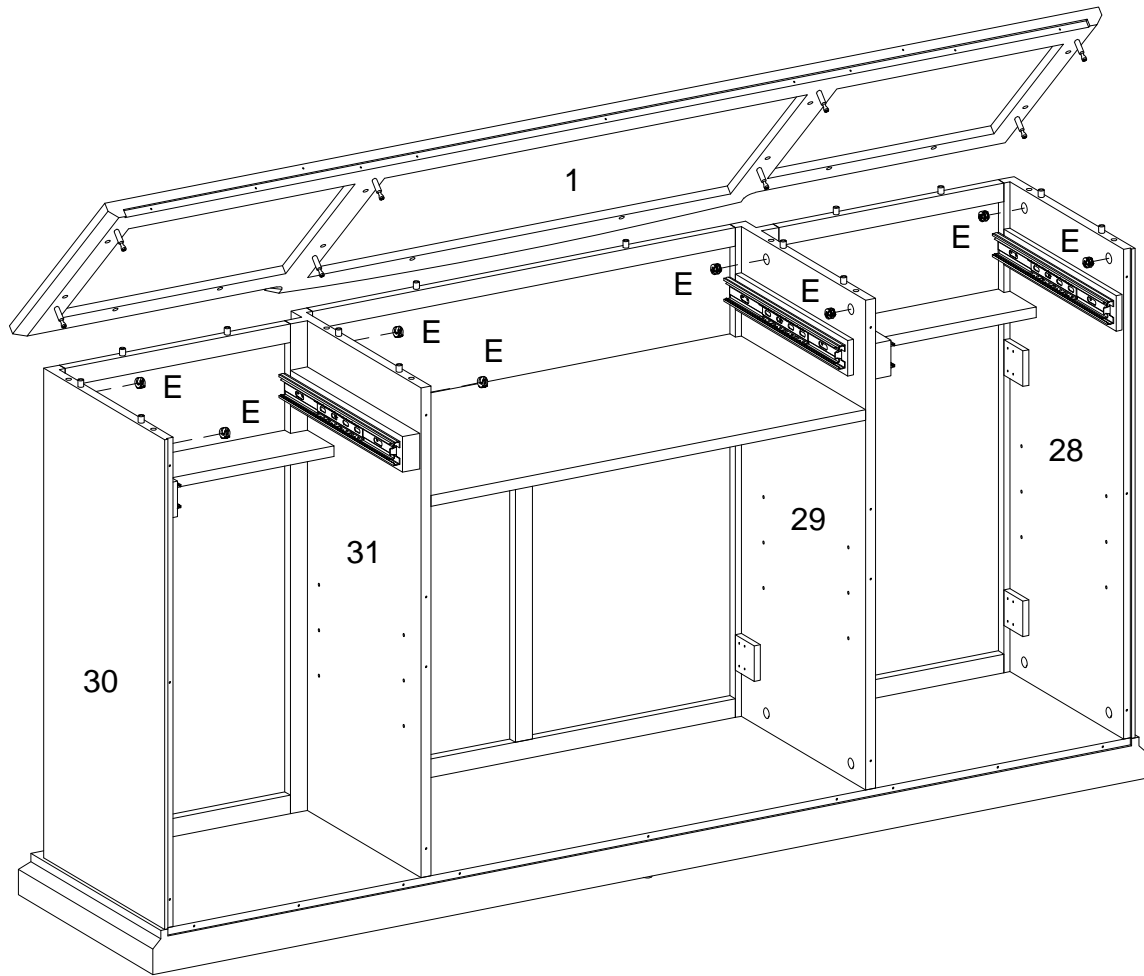
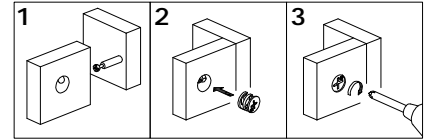

Using cam lock (E) attach part (1) to parts (28,29,30,31) with Philips head screwdriver as per diagram.

Step 15

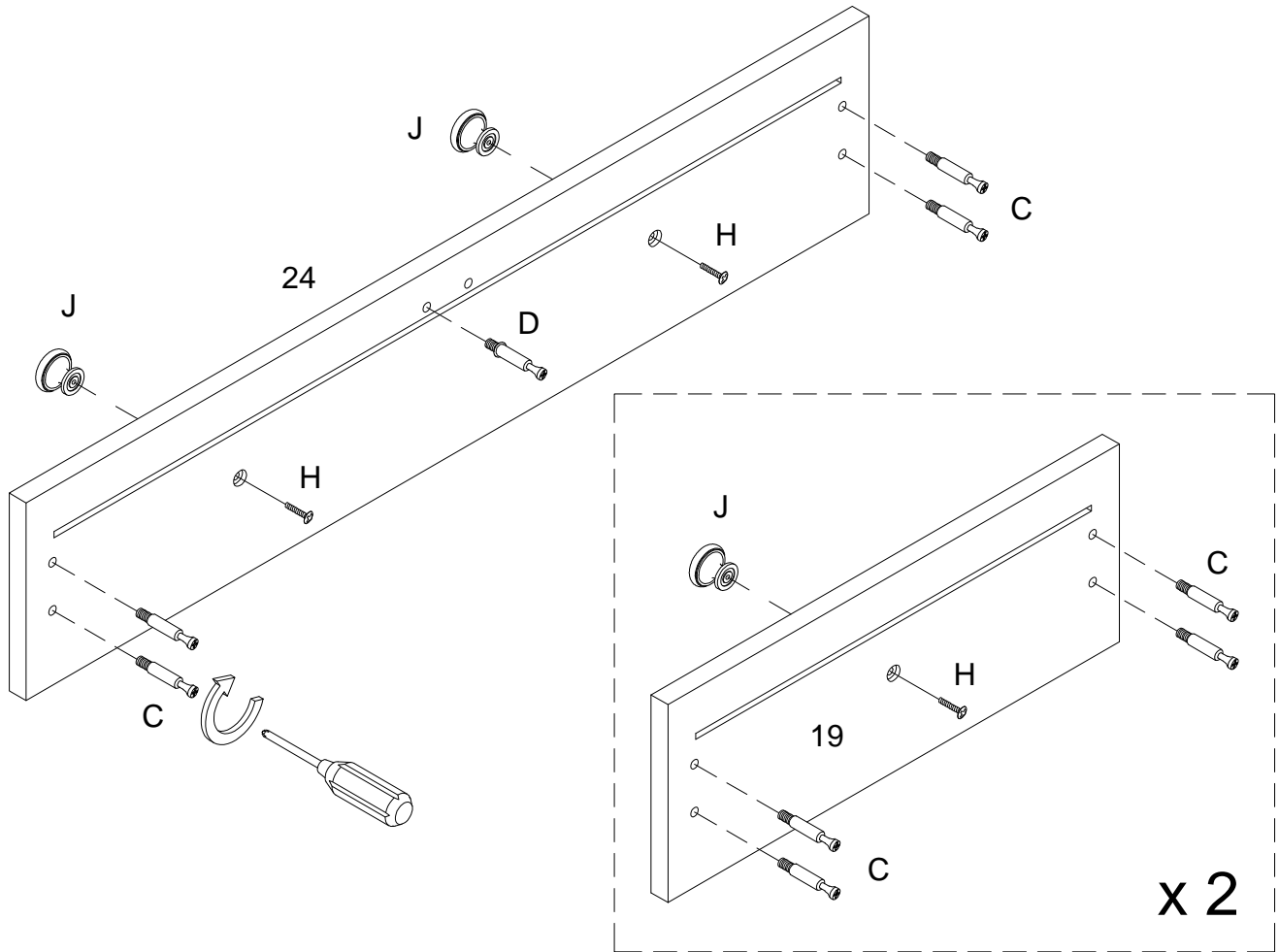

Secure cam bolt (D) to part (24), cam bolt (C) into parts (19,24), then using handle bolt (H) attach handle (J) to parts (19,24) with Philips head screwdriver as per diagram.

Step 16

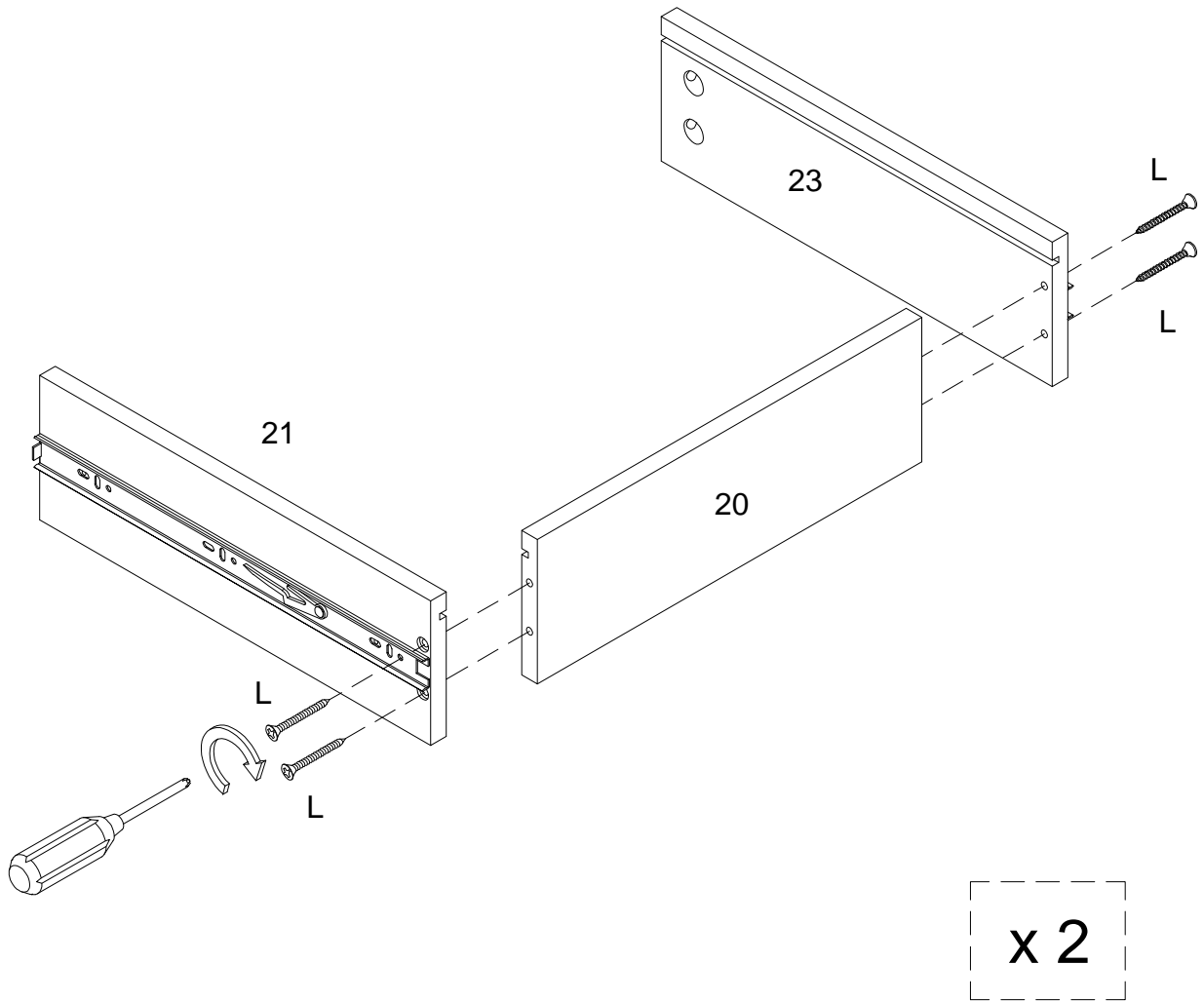

Using Flat head screw (L) attach parts (21,23) to part (20) with Philips head screwdriver as per diagram.

Step 17

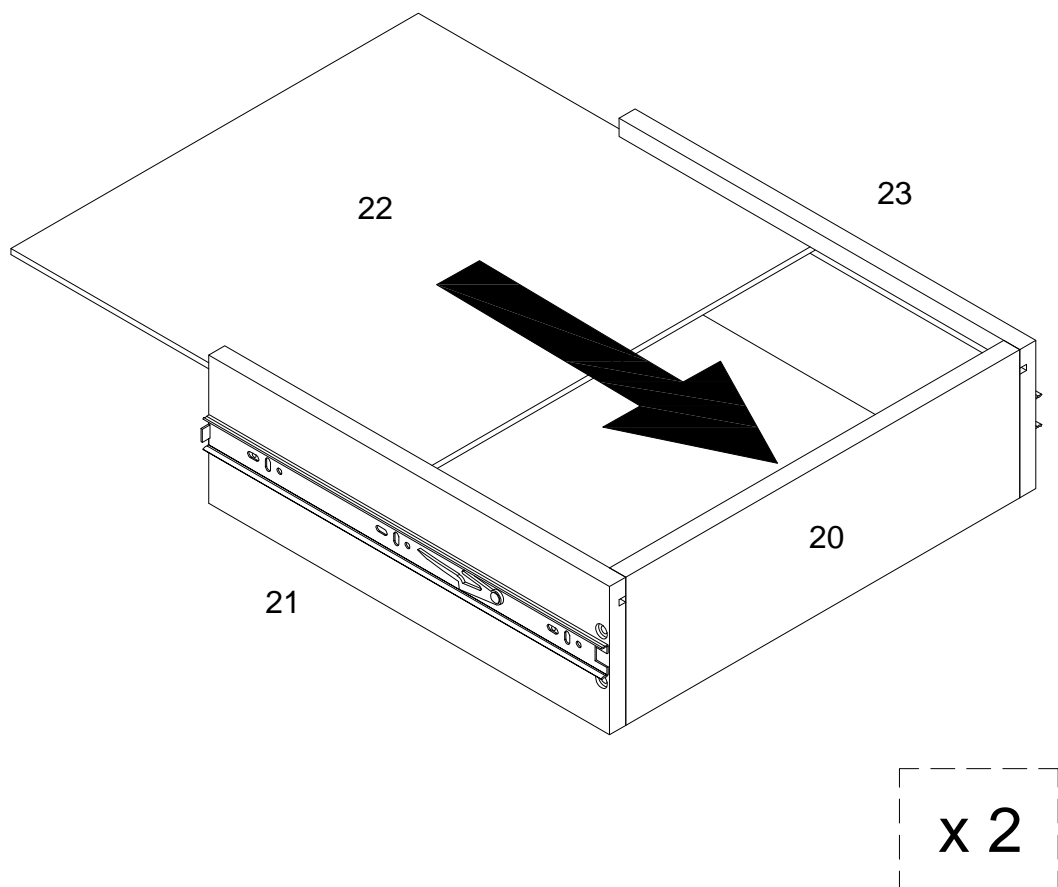

Put part (22) as per diagram.

Step 18

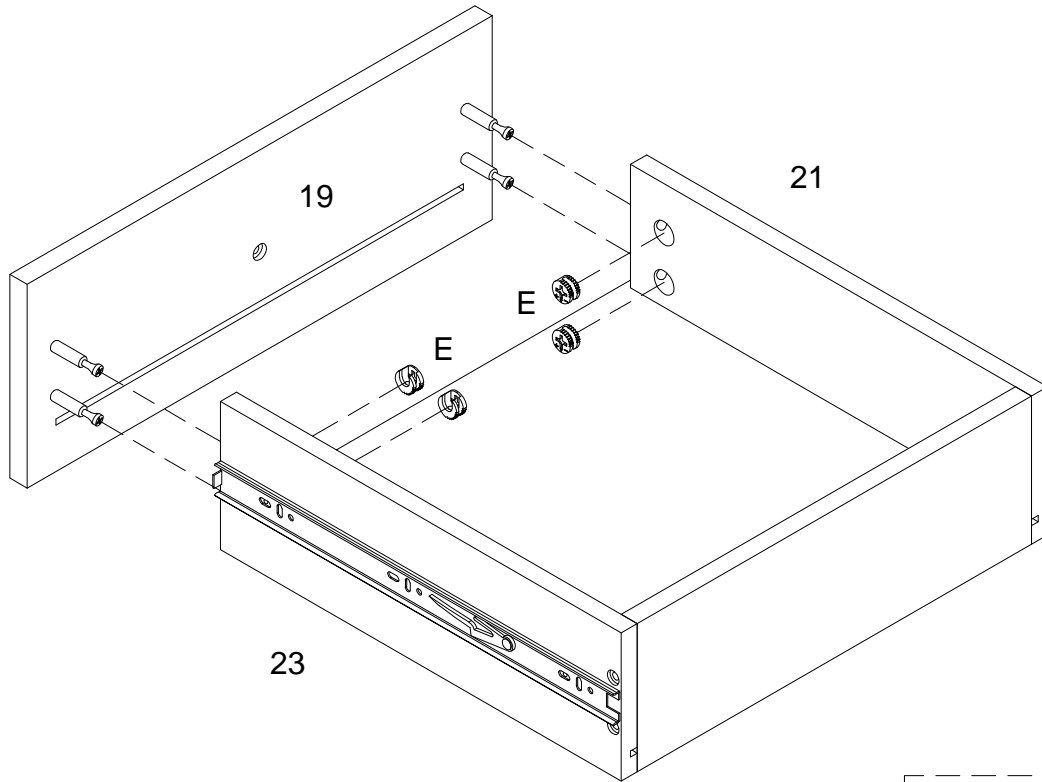
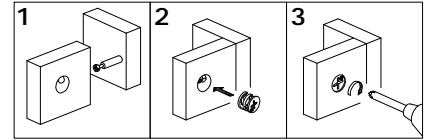

x 2

Using cam lock(E) attach part (19) to parts (21,23) with Philips head screwdriver as per diagram.

Step 19

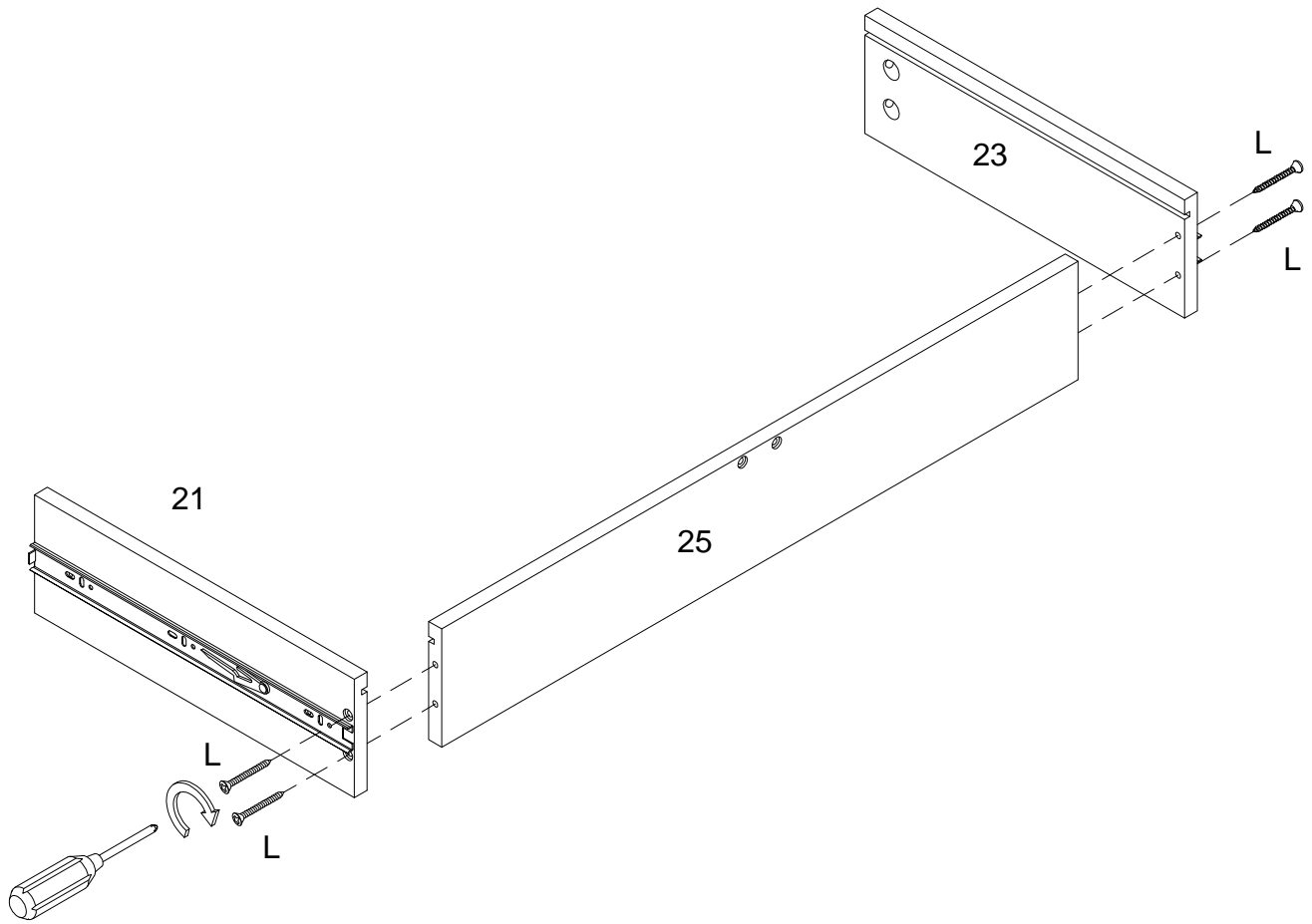

Using Flat head screw (L) attach parts (21,23) to part (25) with Philips head screwdriver as per diagram.

Step 20

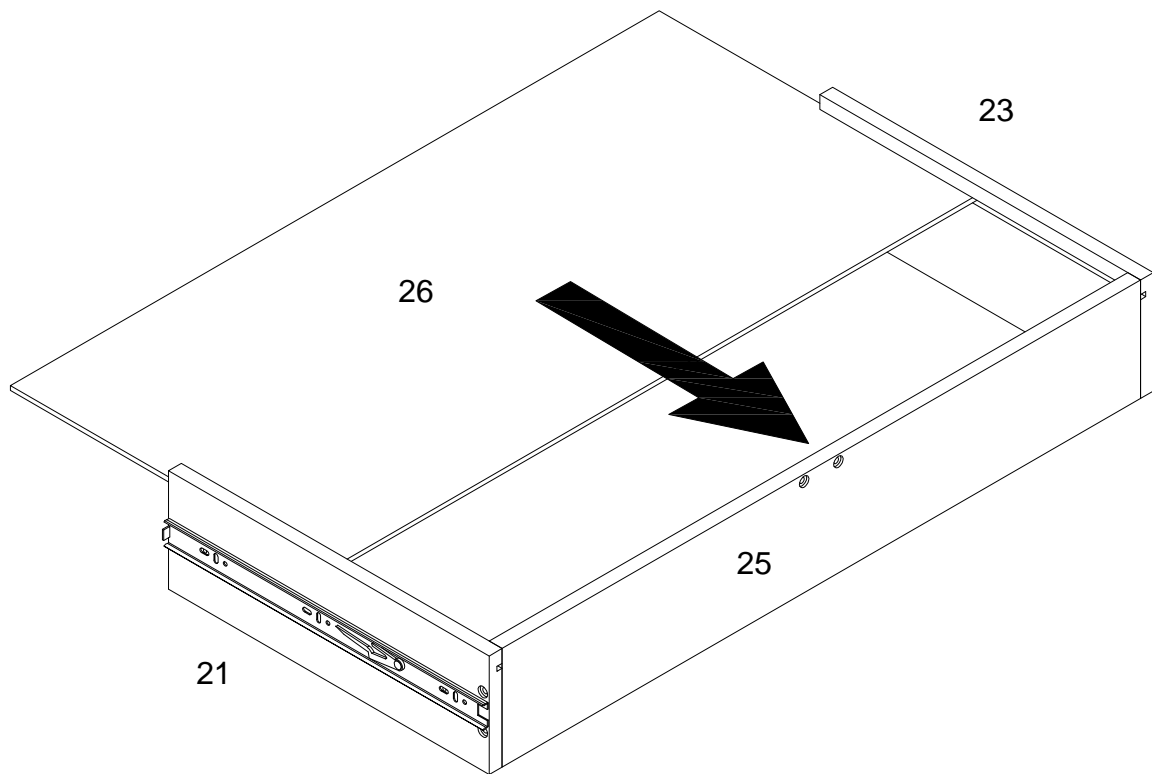

Put part (26) as per diagram.

Step 21

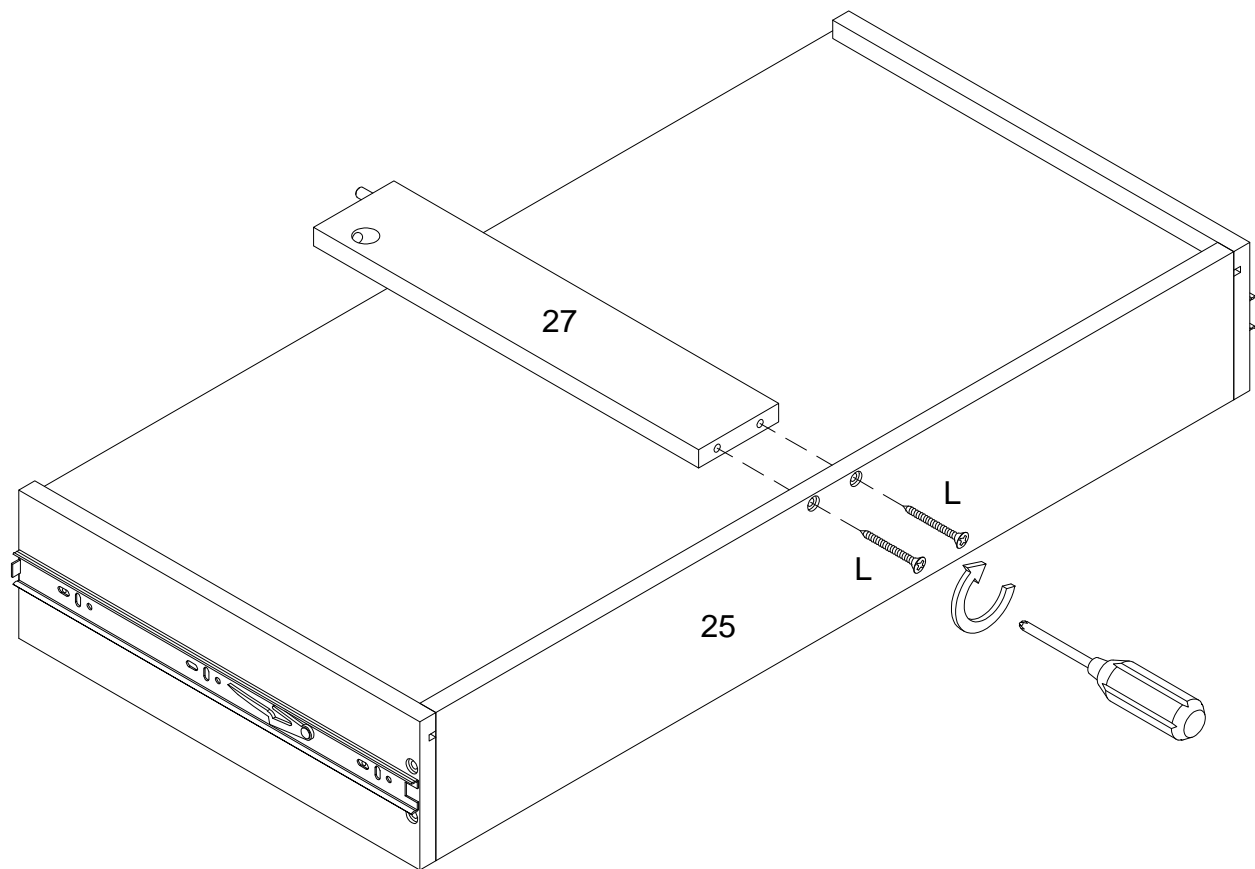

Using Flat head screw (L) attach part (25) into part (27) with Philips head screwdriver as per diagram.

Step 22

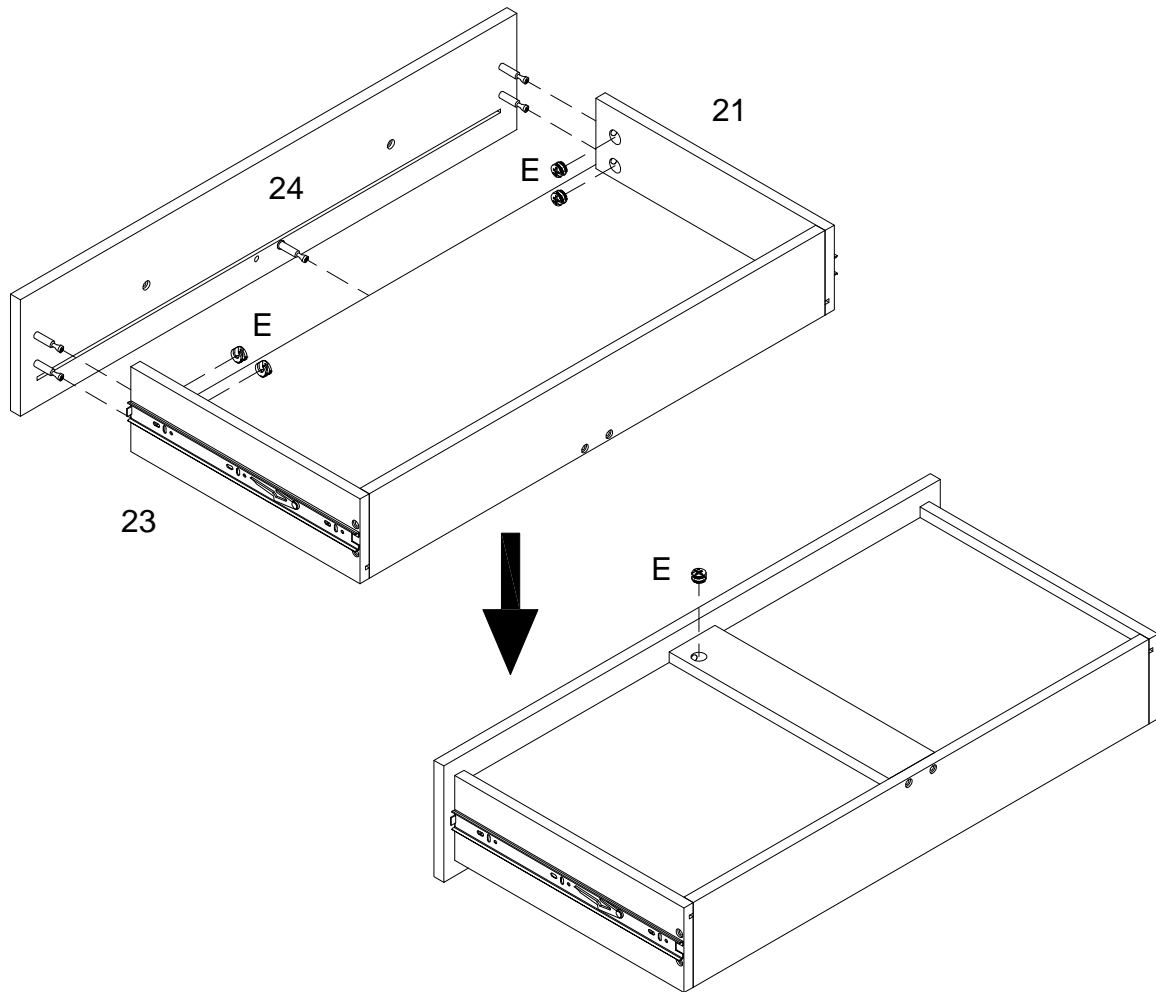
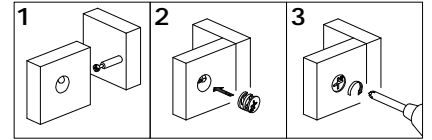

Using cam lock(E) attach part (24) to parts (21,23) with Philips head screwdriver as per diagram.

Step 23

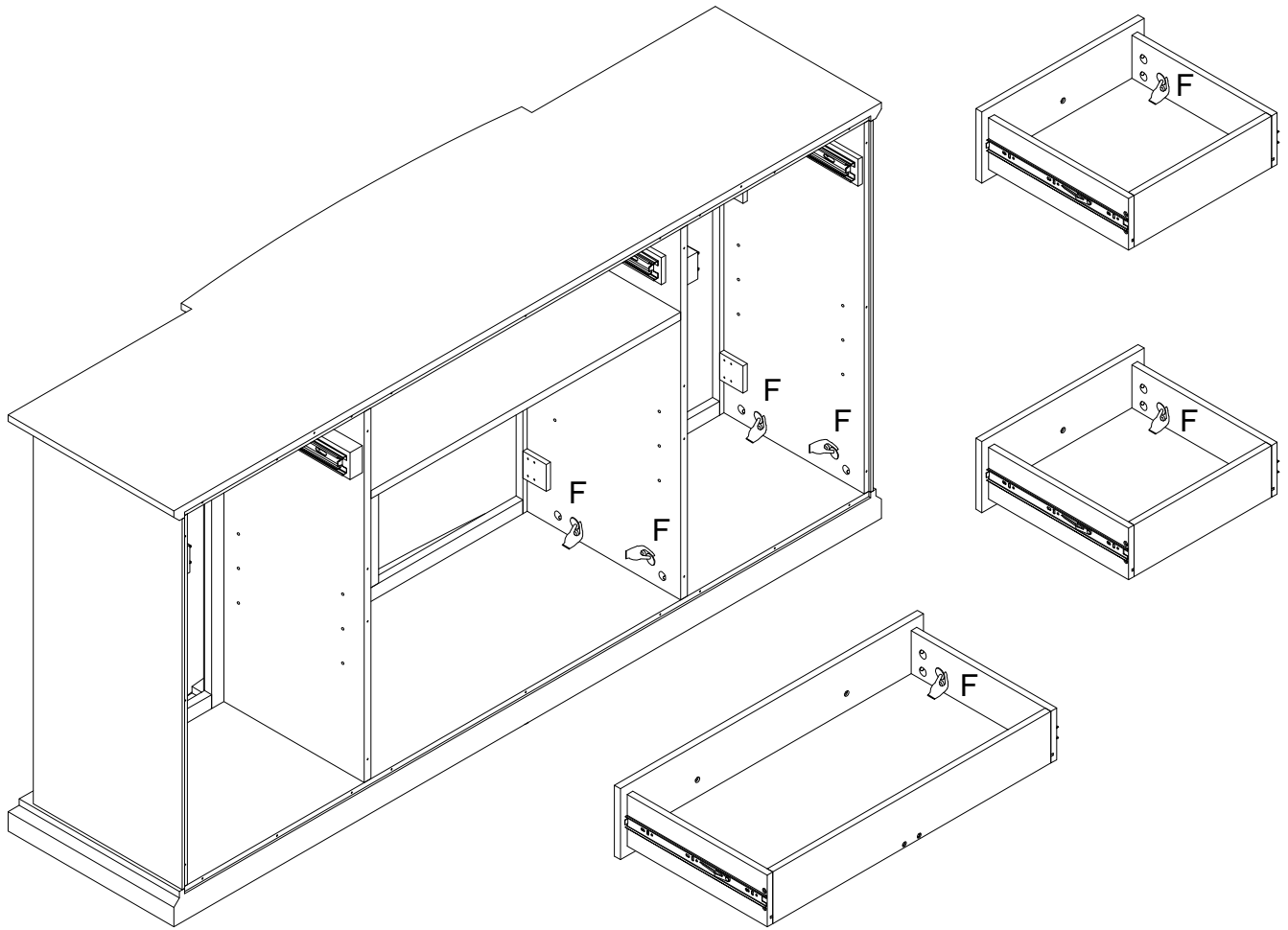

Place sticker (F) cover the holes as per diagram .

Step 24

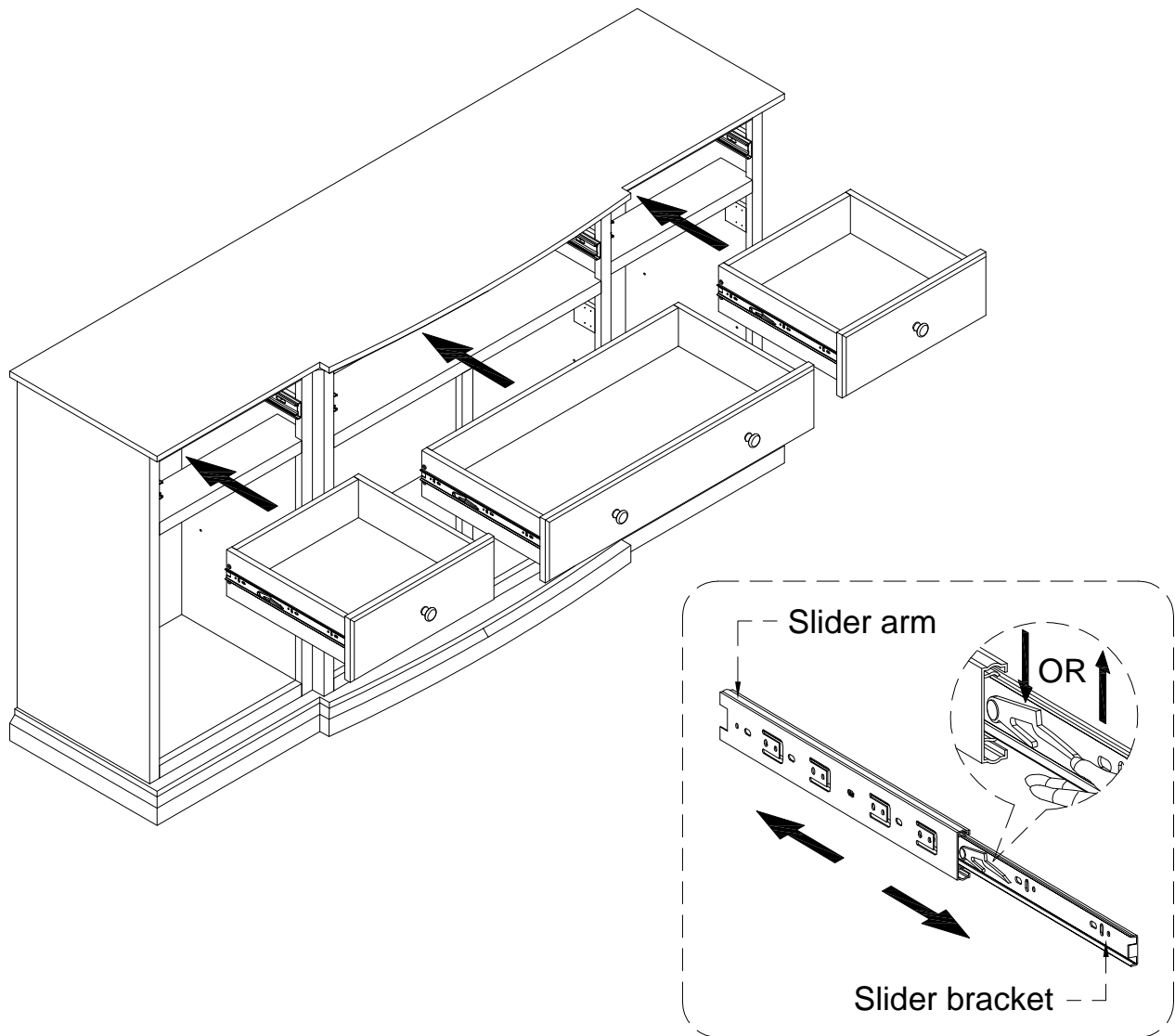

Insert the assembled drawers into the unit frame, extend the Ball Bearing Slide Tracks on the pedestal Side Panel all the way forward. Then align the Slide Runners on the assembled drawers with the Slide Tracks and push the drawer carefully inside until it stops. Note : if the drawer does not go in smoothly, please take it out and repeat the step. If you need to remove the drawer, please pull the drawer all the way out, press or lift the plastic release lever and pull out the drawer and then re-assembled the drawer until it was going in smoothly

Step 25

x 2

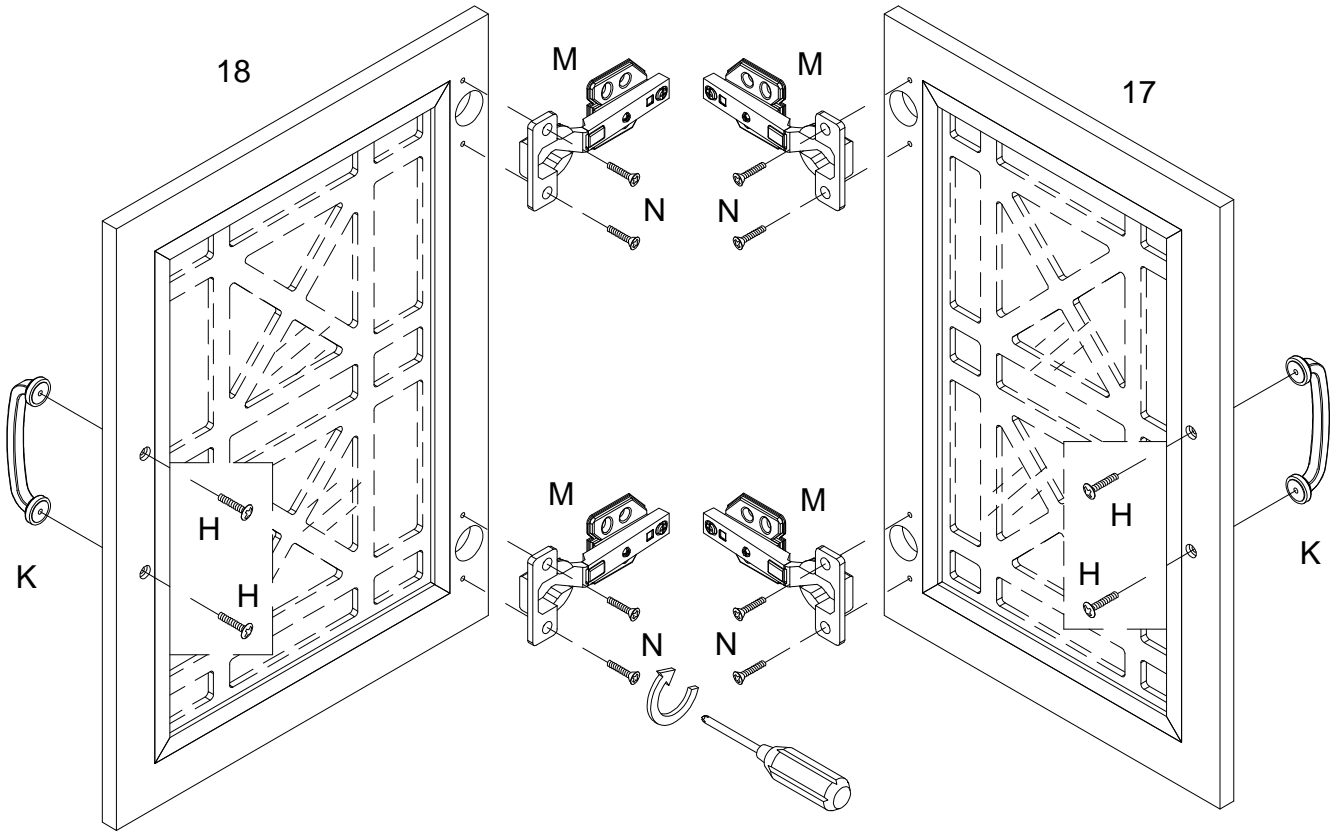

Using bolt (N) attach Europe hinge (M) ,Handle bolt (H) attach handle (K) into parts (17,18)with Philips head screwdriver as per diagram.

Step 26

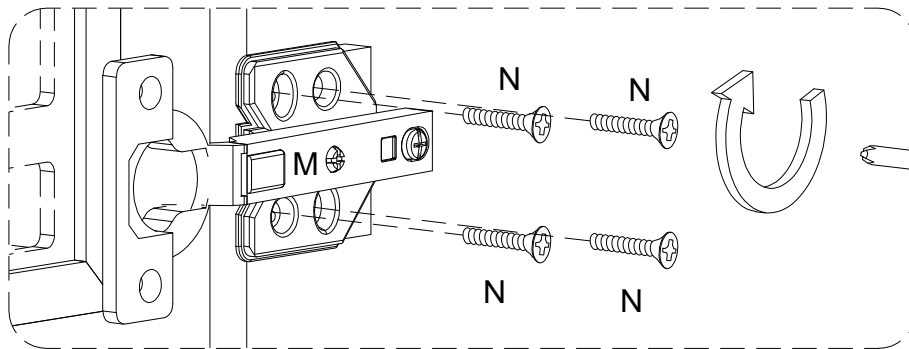
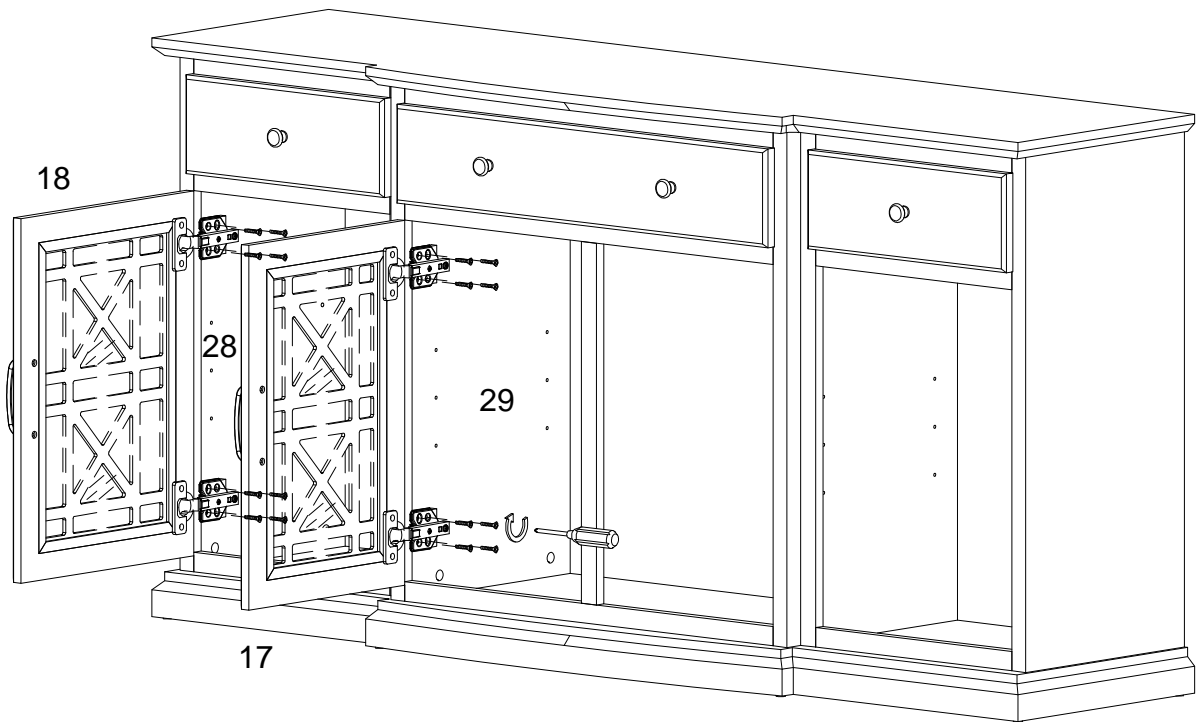

Using bolt (N) attach Europe hinge (M) into parts (28,29) with Philips head screwdriver as per diagram.

Step 27

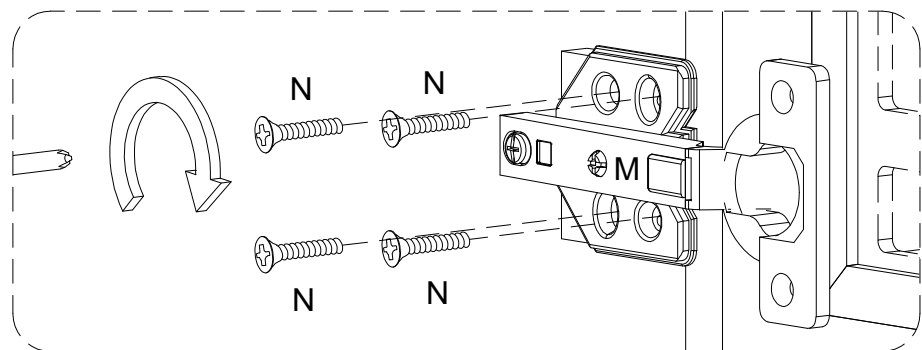
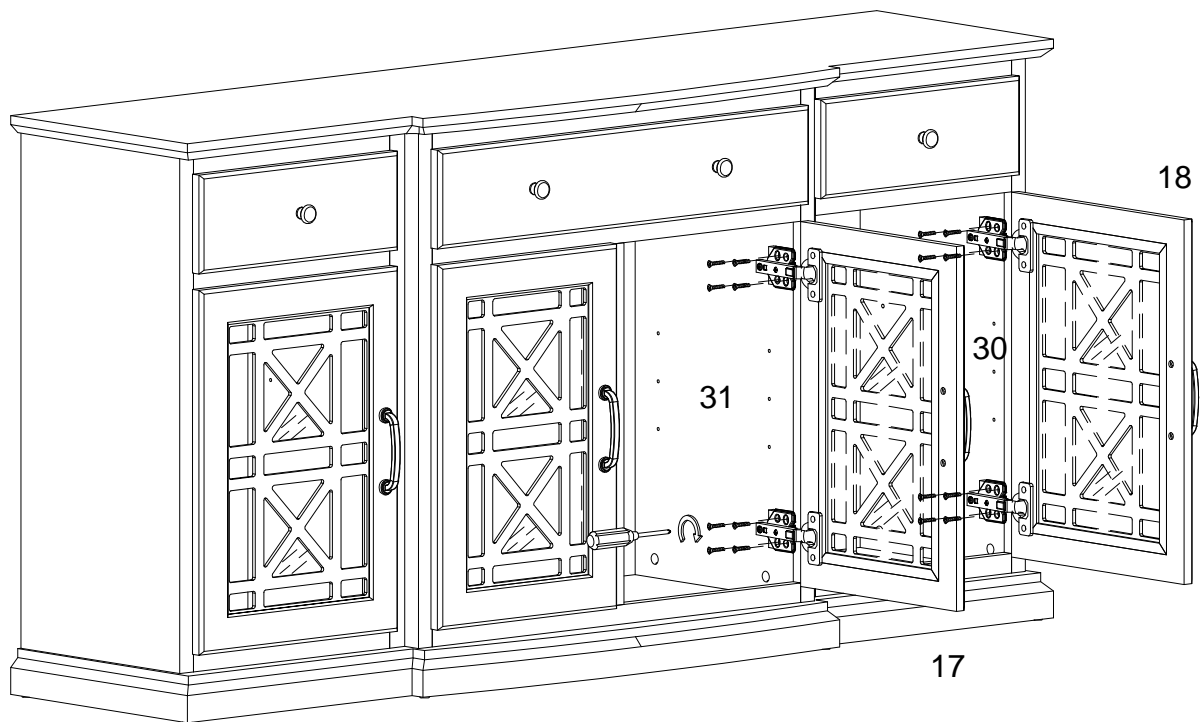

Using bolt (N) attach Europe hinge (M) into parts (30,31) with Philips head screwdriver as per diagram. Open and close the doors .If necessary adjust the screws for a good fit .

Step 28

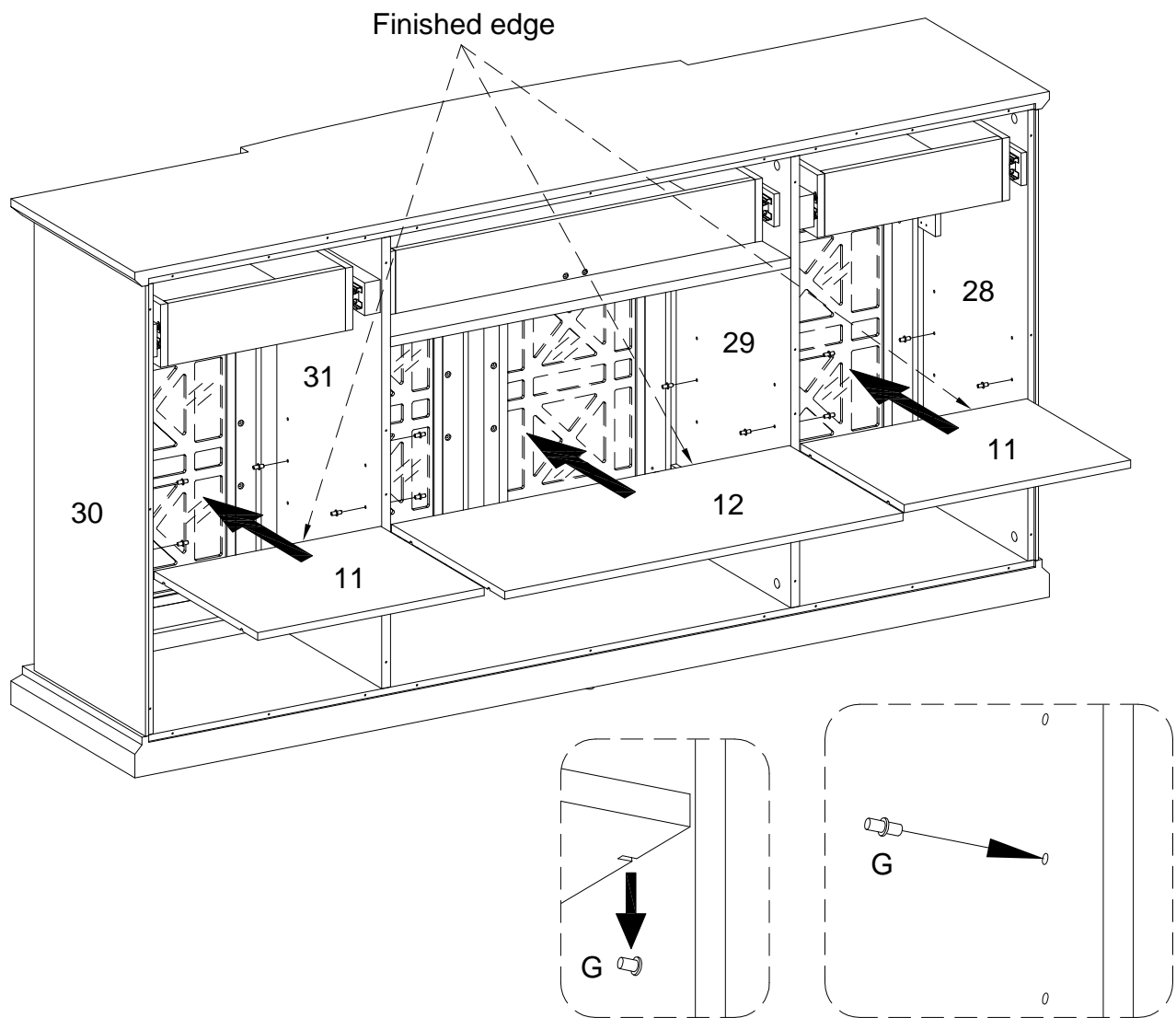

Insert shelf support pin (G) into parts (28,29,30,31) as per diagram. Make sure you place the four shelf support pins (G) in the same level. So the shelf is not titled. Put parts (11,12) into unit as per diagram. Tilt and rest the adjustable shelf(11,12) onto the shelf support pins.

Step 29

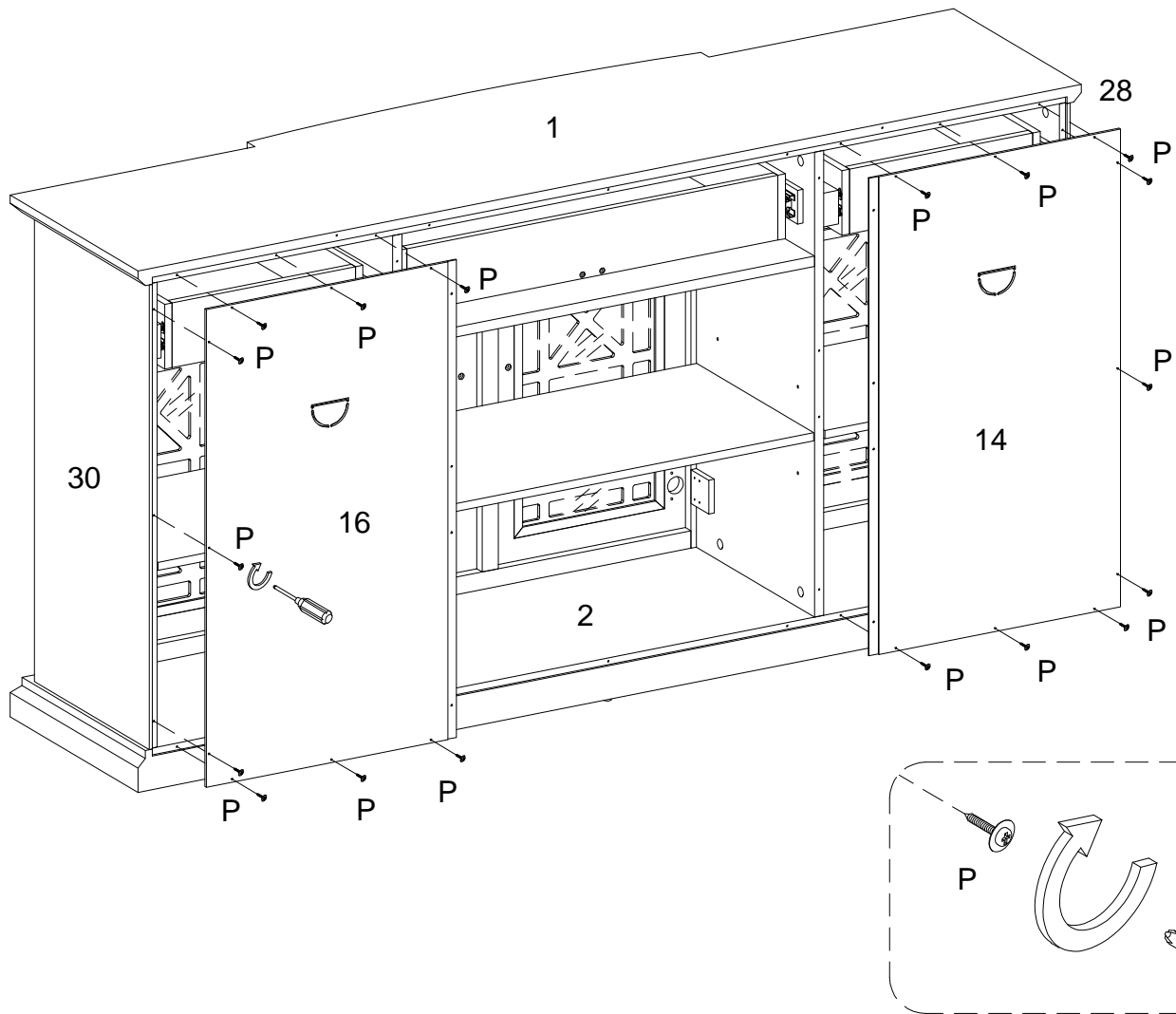

using flat head screw (P) attach part (14) to parts(1,2,28),part(16) to parts(1,2,30) with Philips head screwdriver as per diagram.

Step 30

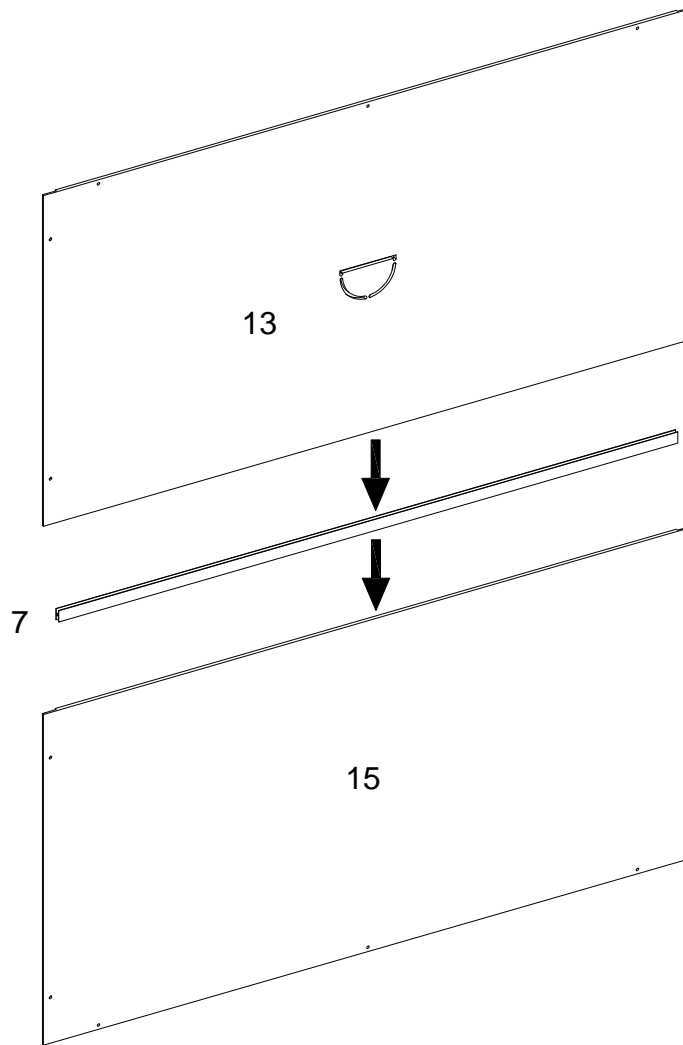

Attach parts (7,13,15) as per diagram.

Step 31

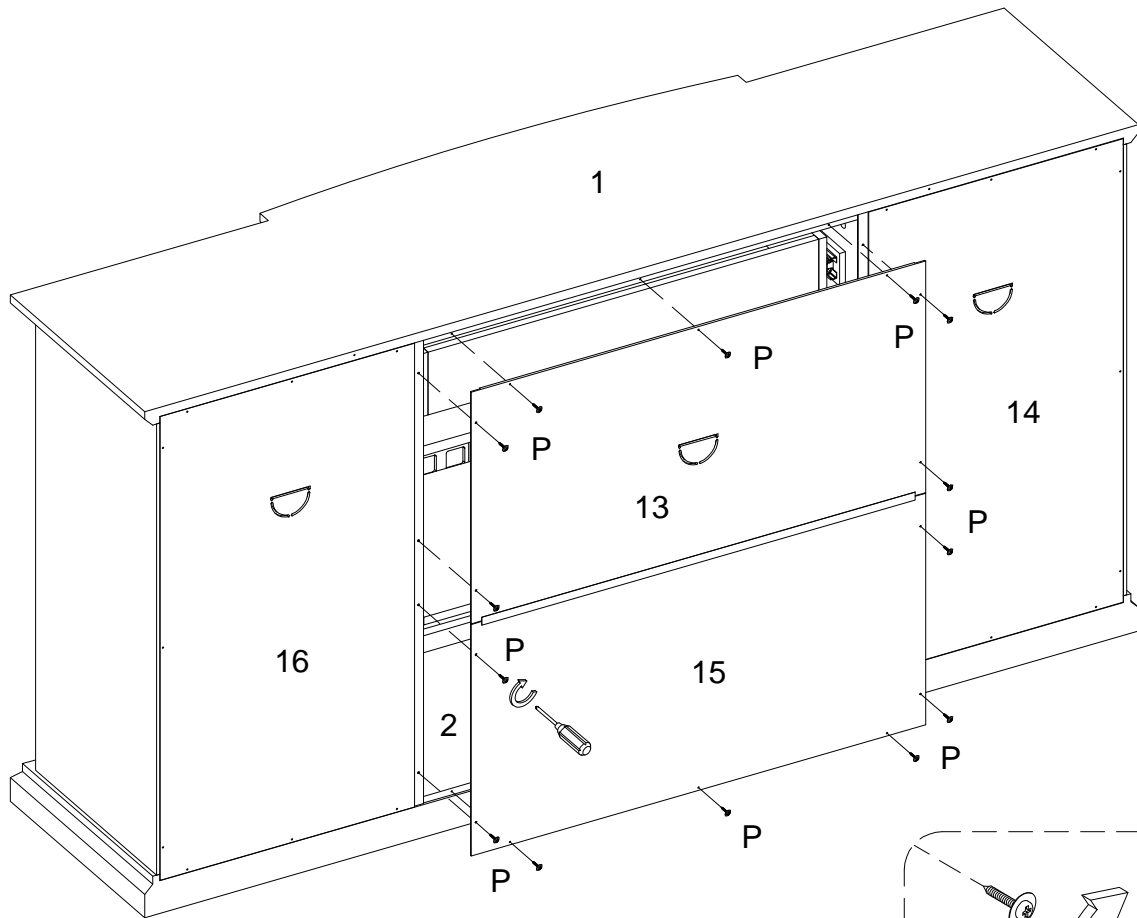

Using Flat head screw (P) attach parts (13,15) into parts (1,2,29,31) with Philips head screwdriver as per diagram.

Step 32

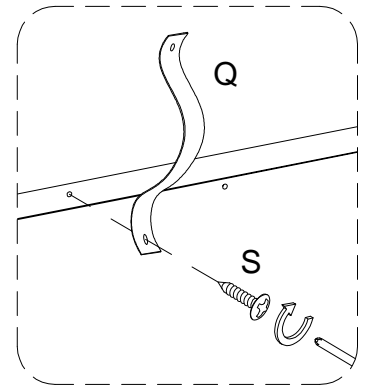
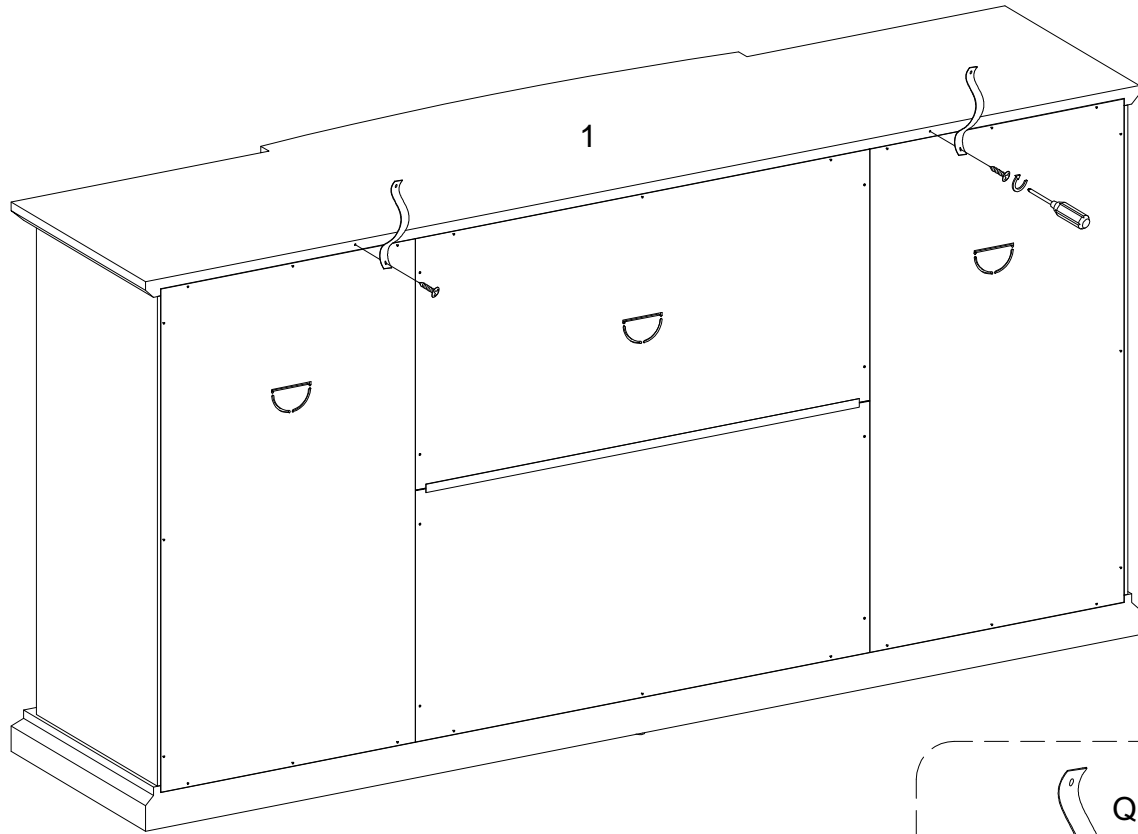

Using screw (S) attach Velcro strap (Q) to part (1) with Philips head screwdriver as per diagram.

Step 33

WARNING

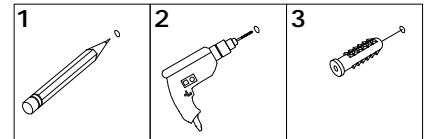

Serious or fatal injuries can occur from furniture tipping over. To prevent the furniture from tipping over we recommend that it is permanently fixed to the wall. Wall anchor and hardware are included with this product. Please make sure hardware is suitable for your walls before installing, as different wall materials may require different types of anchors.

Wall

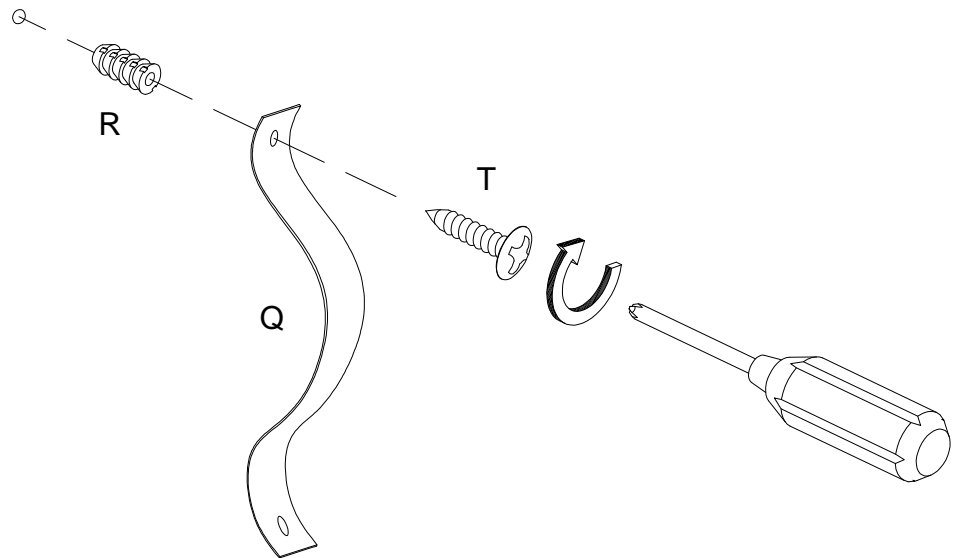

Using screw (T) attach plastic strap (Q) into nut (R) to wall with Philips head screwdriver as per diagram.

Step 34

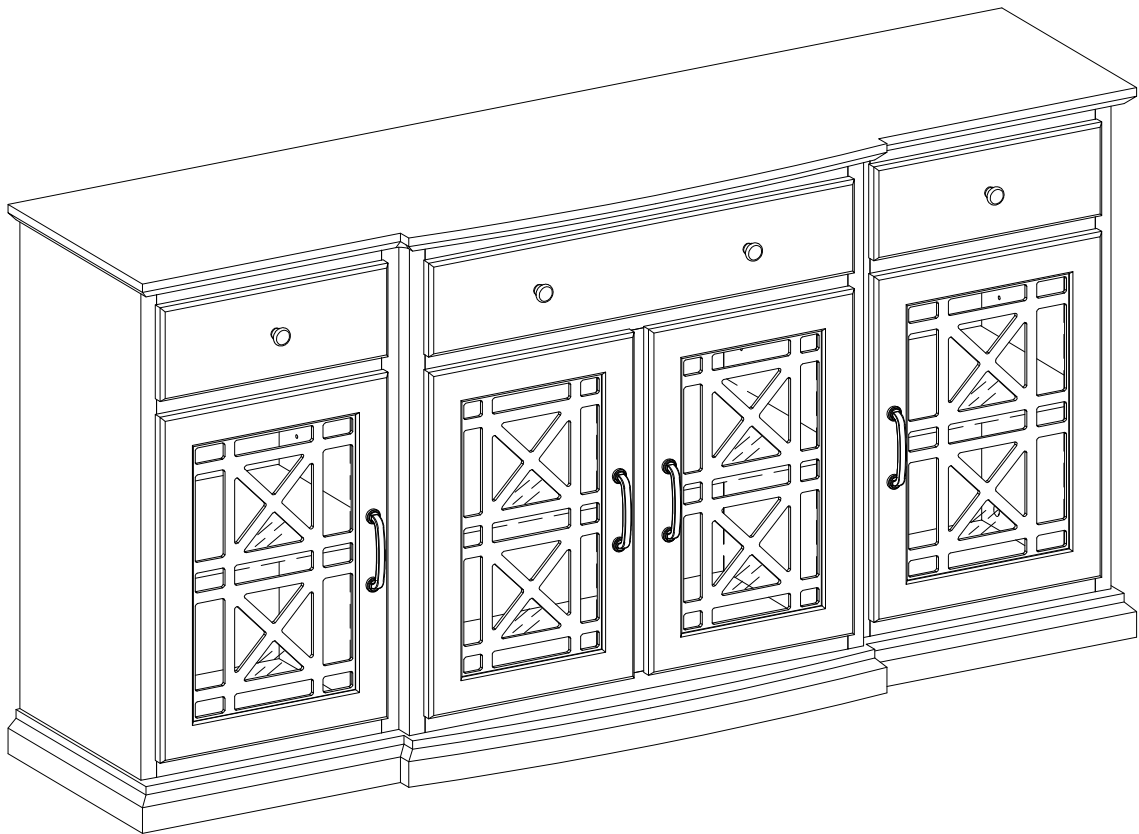

Final Assembly