

User Manual

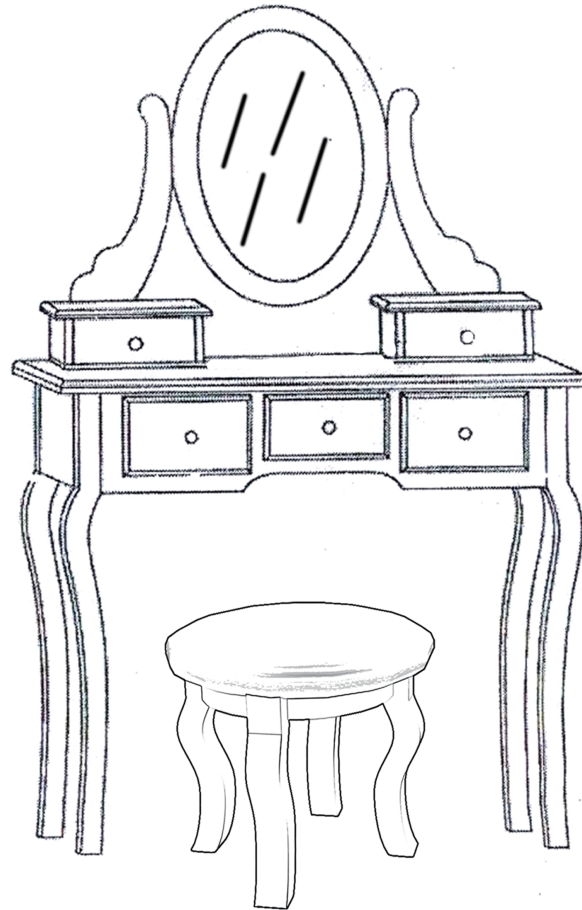

You need

1 Tools required

A Phillips head screwdriver is required for the assembly of this product. (not included)

Power tools should not be used to assemble this product.

2 1 person is needed

3 Take 30 minutes

Technical Specifications	
Size	750X400X1340mm
Max weight capacity	330LBS

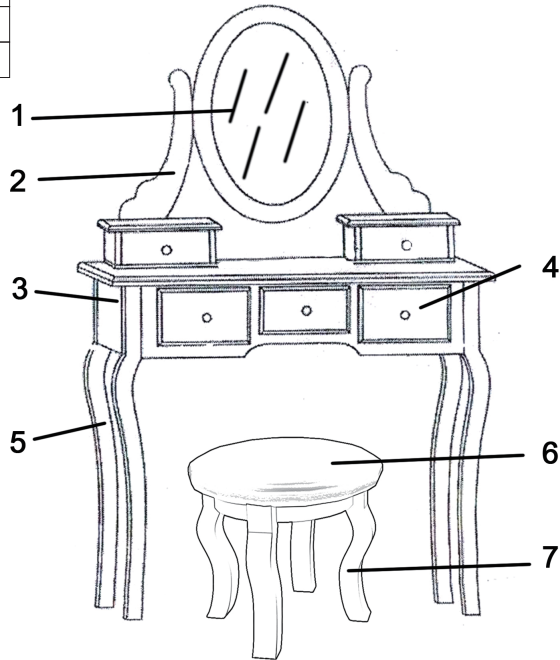

No	Description	Quantity	No	Description	Quantity
1	MIRROR	1	5	TABLE LEGS	4
2	WOODEN PROP	2	6	CUSHION	1
3	DESKTOP	1	7	CHAIR LEGS	4
4	WOODEN DRAWER	5	8		

Hardware List

A 8PCS	B 4PCS	C 2PCS	D 2PCS
E 1PC	F 8PCS		

PRODUCT ASSEMBLY

! Check the package contents before getting started !

STEP 1

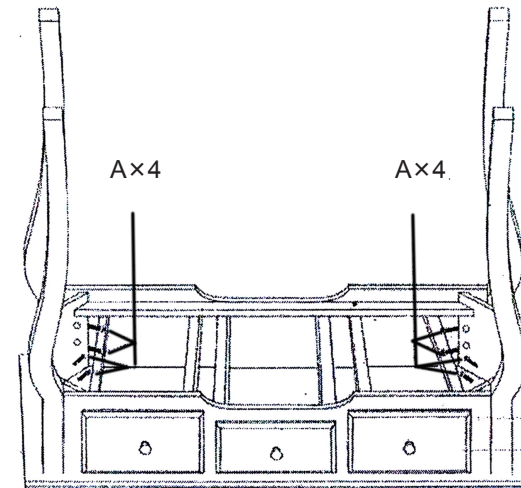

Do not screw all the screws when installing the table legs and stool legs. Keep half-screw state until all installation adjustments are complete before screwing the screws.

STEP 2

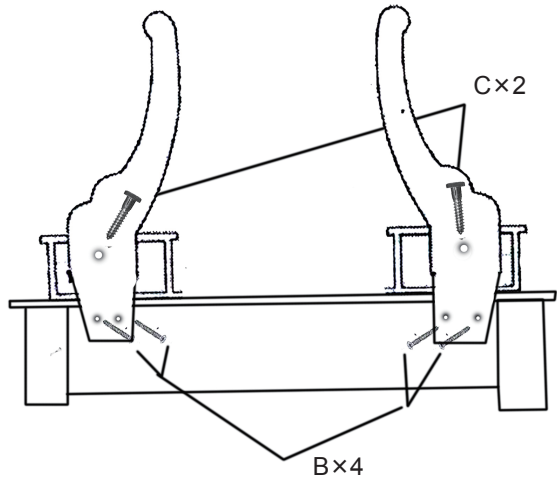

STEP 3

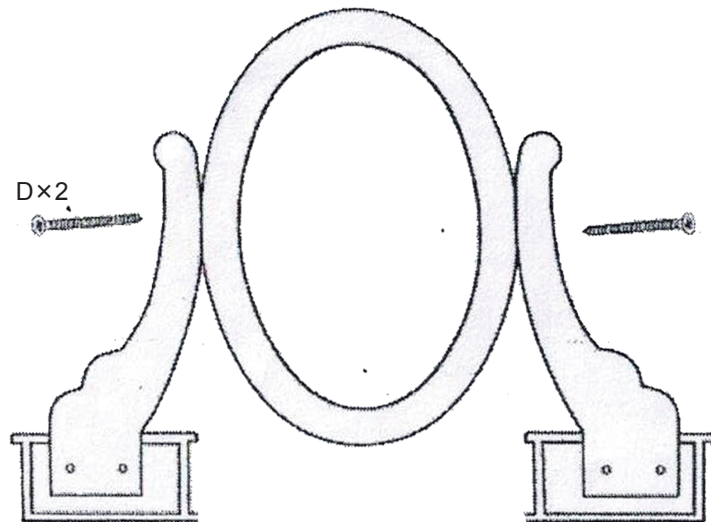

STEP 4

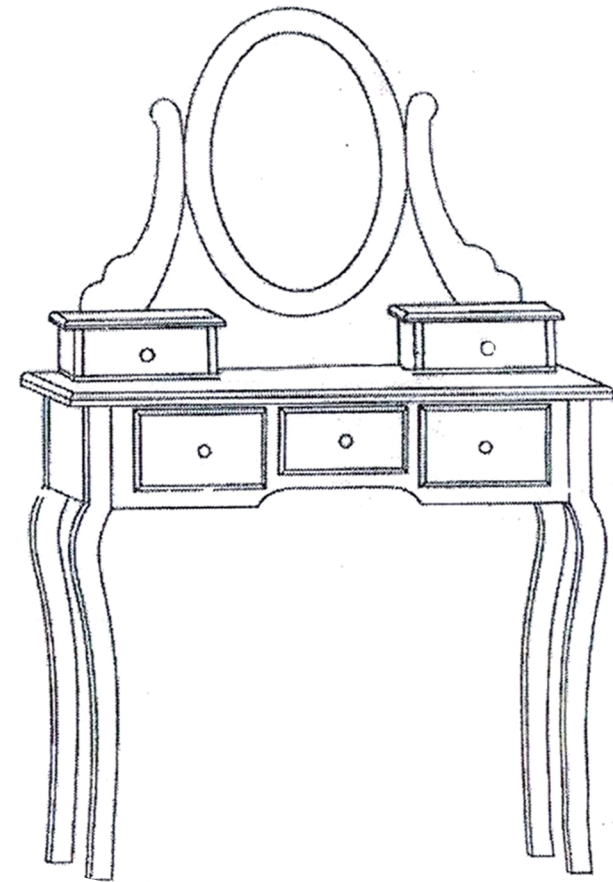

DRESSING TABLE FINISH

STEP 5

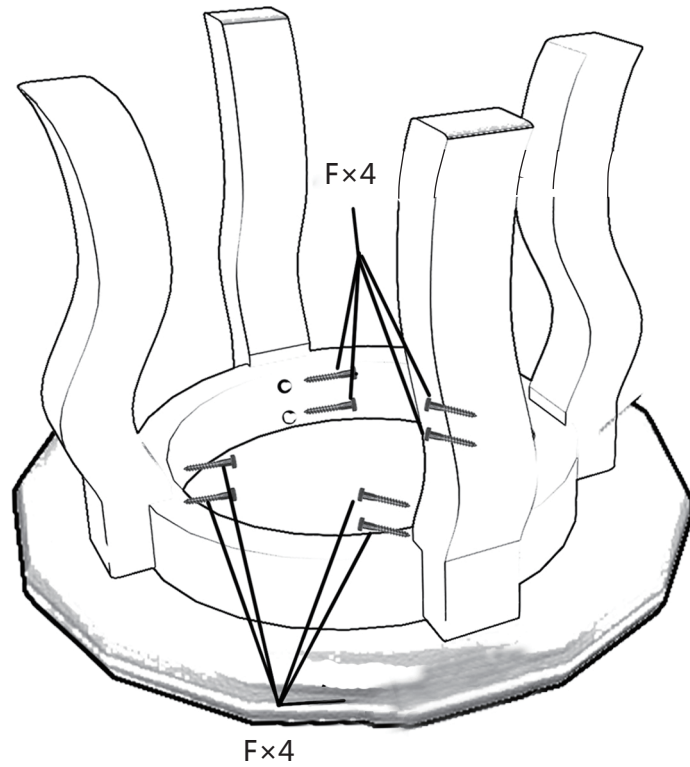

Do not screw all the screws when installing the table legs and stool legs. Keep half-screw state until all installation adjustments are complete before screwing the screws.

STEP 6

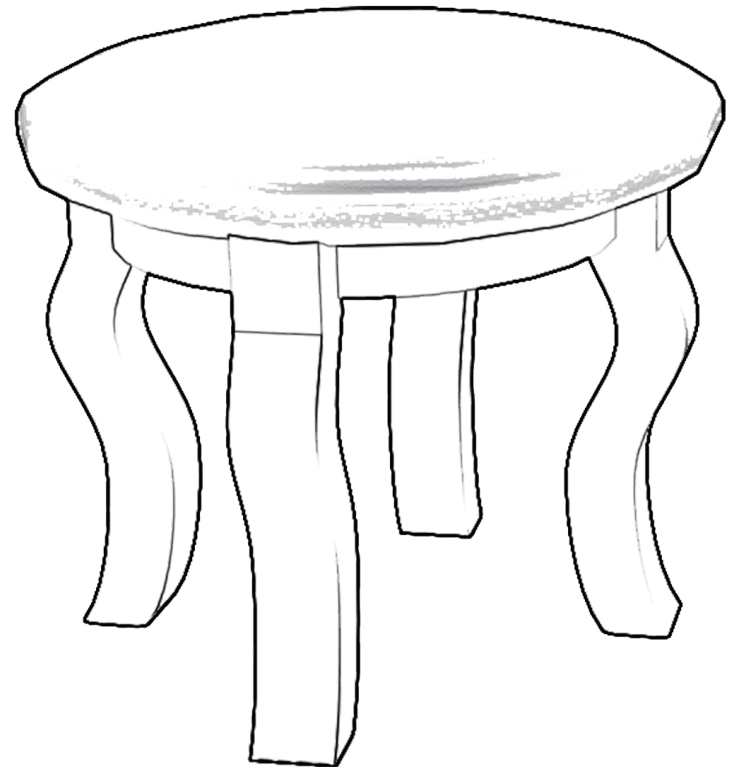

STOOL FINISH