

ASSEMBLY INSTRUCTIONS

IMPORTANT NOTE :







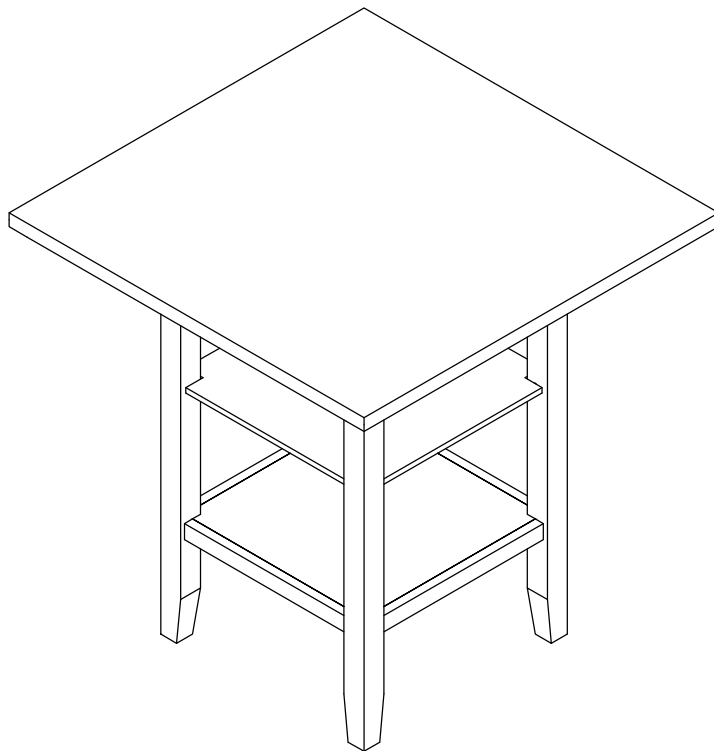

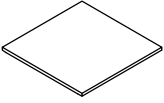

** PLACE ALL PARTS ON A CLEAN AND SMOOTH SURFACE SUCH AS A RUG OR CARPET TO AVOID THE PARTS FROM BEING SCRATCHED.

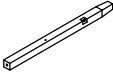
** BEFORE YOU BEGIN, KINDLY FOLLOW THE ASSEMBLY INSTRUCTIONS STEP BY STEP.

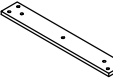
**DO NOT TIGHTEN ALL SCREWS AND BOLTS UNTIL THE TABLE IS FULLY SET-UP.

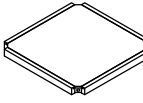

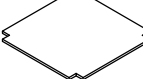
CARTONS ONLY ONE/ CARTONS SEULEMENT UN

PART LISTS				HARDWARE LISTS			
NO.	DESCRIPTION	SKETCH	Q'TY	NO.	DESCRIPTION	SKETCH	Q'TY
1	TABLE TOP		1 PC	A	BOLT Ø5/16" x 30mmL		10 PCS
2	LEGS		4 PCS	B	BOLT Ø5/16" x 50mmL		8 PCS
3	SUPPROT		2 PCS	C	SPRING WASHER Ø1/4" x 13mmL		18 PCS
4	RIGHT STRECHER		1 PC	D	FLAT WASHER Ø1/4" x 19mmL		18 PCS
5	FRONT STRECHER		1 PC	E	ALLEN KEY		4 PCS
				F	ALLEN KEY		4 PCS

ASSEMBLY INSTRUCTIONS

STEP 1:

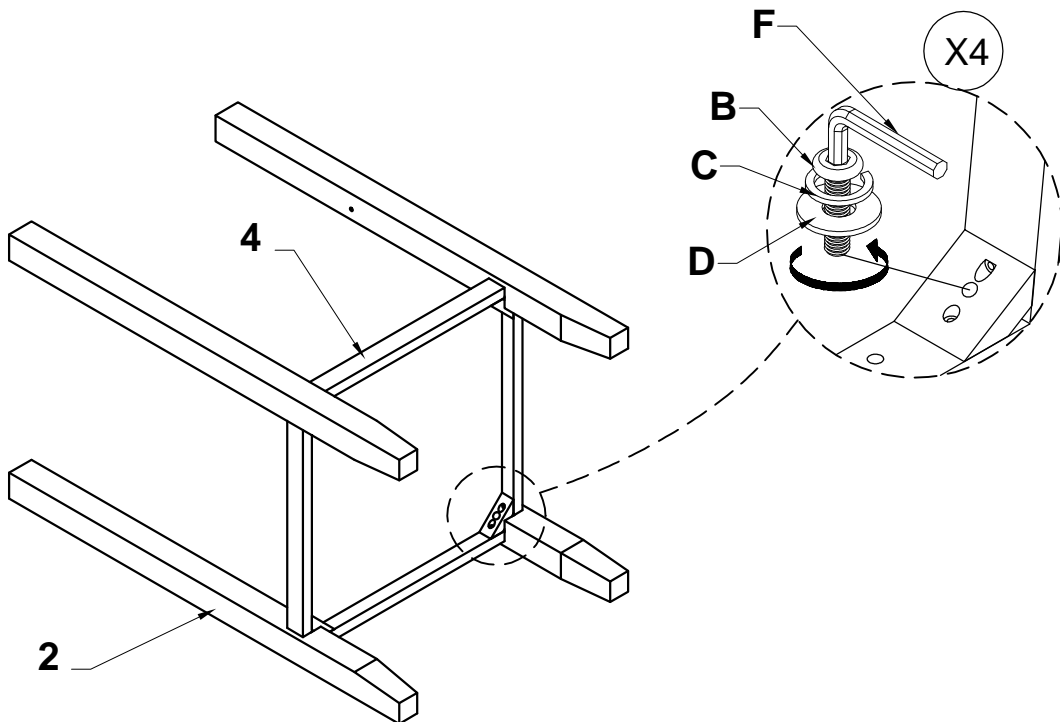

ASSEMBLY INSTRUCTIONS

STEP 2:

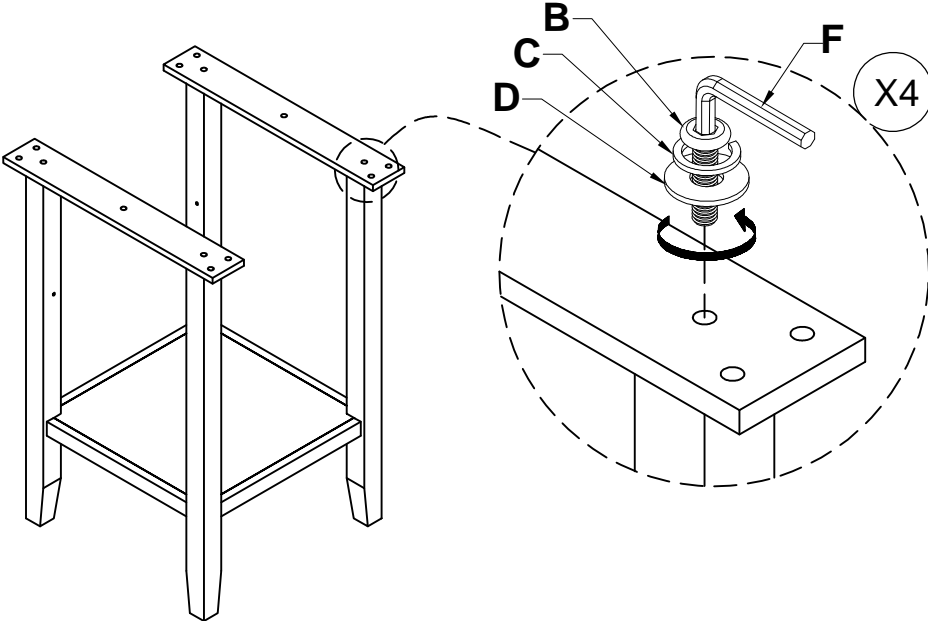

STEP 3:

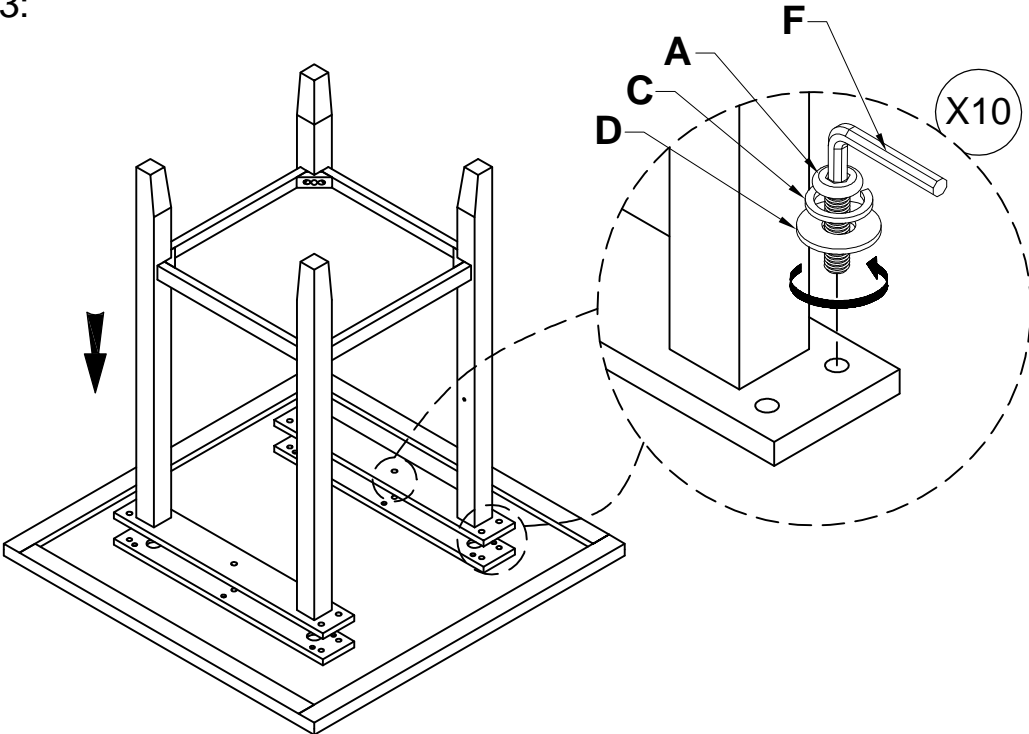

ASSEMBLY INSTRUCTIONS

STEP 4:

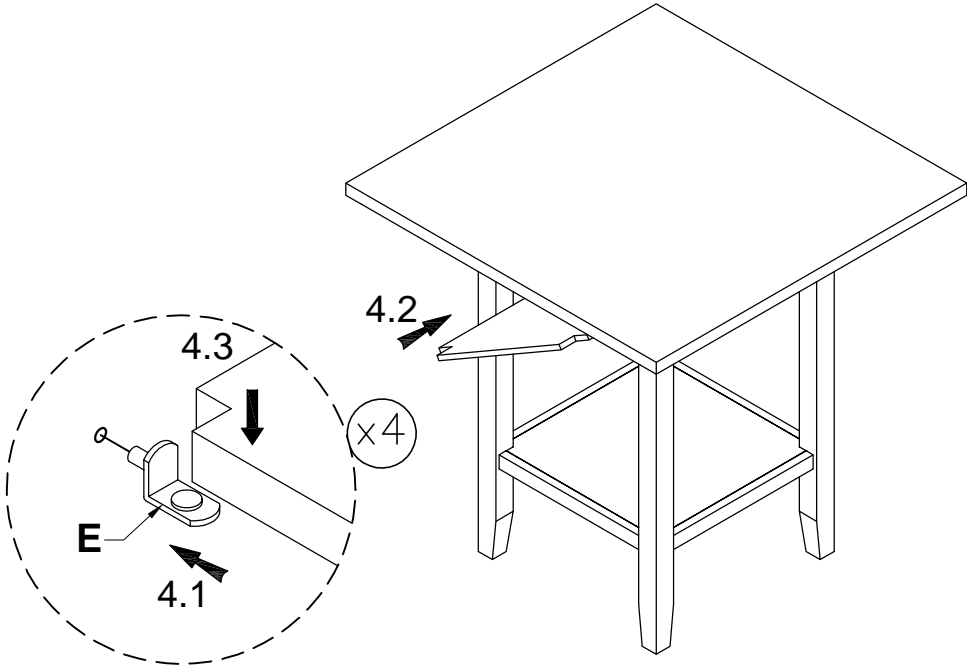

STEP 5:

