

# ASSEMBLY INSTRUCTIONS

## 3-piece Upholstered Dining Set Table

ASSEMBLY  
REQUIREMENTS

2-Person  
Assembly

2 Hours  
Assembly Time  
(Approximate)

Tools Required  
(Not Provided)

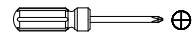

Phillips Screwdriver



Flat Screwdriver

### Thank you for purchasing our product!

Please refer and use this assembly instruction to assemble the product.

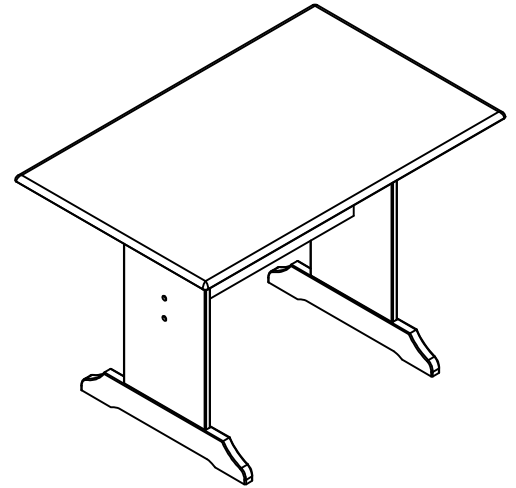

### ASSEMBLY PREPARATION

1. Remove all packaging materials, staples and packing straps from the carton.
2. Refer to Parts List and Hardware List, and ensure parts and hardware are correct before assembly.
3. Place all wooden parts on a clean, flat and soft surface (e.g. carpet or rug) to prevent scratch and damage to parts.

### SAFETY PRECAUTION

1. KEEP ALL HARDWARE PARTS OUT OF REACH OF CHILDREN.
2. DISPOSE PLASTIC PACKAGING MATERIAL IMMEDIATELY TO AVOID ANY RISK OF SUFFOCATION TO CHILDREN AND ANIMALS.

### TIPS FOR ASSEMBLY

1. Allow ample room for assembly and **assemble the product near** where product will be placed.
2. Assemble the product on a surface that does not scratch or damage the exterior gloss and finish of the furniture.
3. Identify all of the parts, hardware and quantities required for each step.
4. During assembly, do not over-tighten any fittings as this may cause damage.
5. DO NOT USE POWER TOOLS TO ASSEMBLE THIS PRODUCT.
6. Always place the product on a flat level surface.
7. Do not sit or stand on the partially assembled product; only use the product for which it is intended.

### CARE AND MAINTENANCE







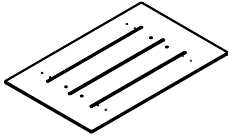
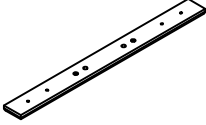
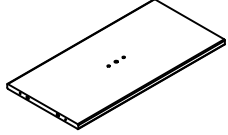
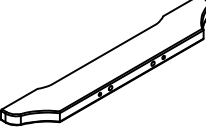
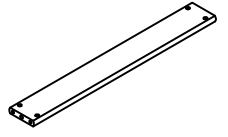

- Use a slightly damp cloth to clean the product. Do not use bleach or abrasive cleaning material.
- Check all the fittings periodically and re-tighten as necessary. Do not use the product if any of the parts is damaged or broken.
- Never allow any kind of liquid to remain on your furniture. Absorption can cause wood to warp or delaminate.
- Do not place hot items (e.g. hot drinks) directly onto the wood surface.
- Do not drag and/or pull the furniture.

This product is for indoor and household use only - not for commercial use.

# Parts List

ITEM	DESCRIPTION	PART	QTY	ITEM	DESCRIPTION	PART	QTY
1	Table Top		1pc	4	Table Rail		2pc
2	Leg Panel		2pc	5	Leg Panel Base		1pc
3	Table Cross Bar		1pc				

# Hardware List

ITEM	DESCRIPTION	HARDWARE	QTY	ITEM	DESCRIPTION	HARDWARE	QTY
A	Screw	 5*25mm	8pcs	E	Screw	 6*45mm	4pc
B	Screw	 5*50mm	4pcs	F	Screw Nuts	 6*13mm	4pcs
C	Wood Dowel	 10*50mm	10pcs	G	Cover	 D15*7	4pcs
D	Screw	 5*50mm	4pcs	H	Allen Key		1pcs

## Instructions for Installing Barrel Nut

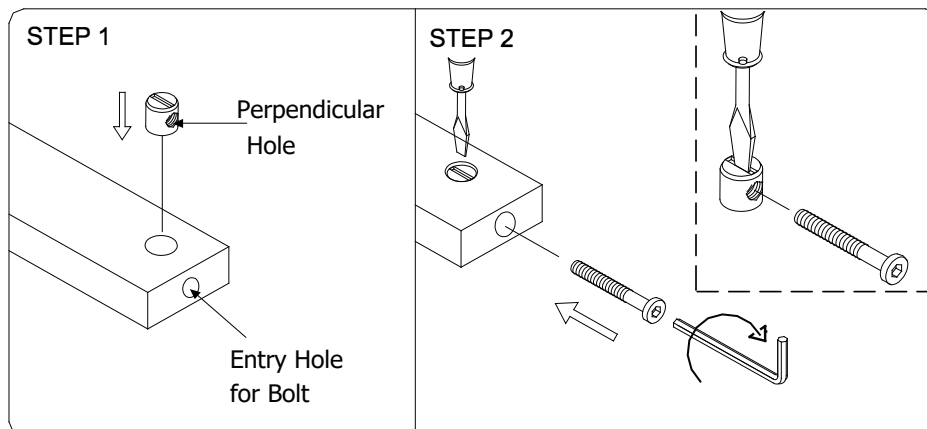

Insert Barrel Nut with the perpendicular hole facing and in-line with the drill hole that the bolt is to be inserted.

Use a Flat-head Screwdriver to hold Barrel Nut in position before inserting bolt to thread into the Barrel Nut.

# Parts Assembly Overview

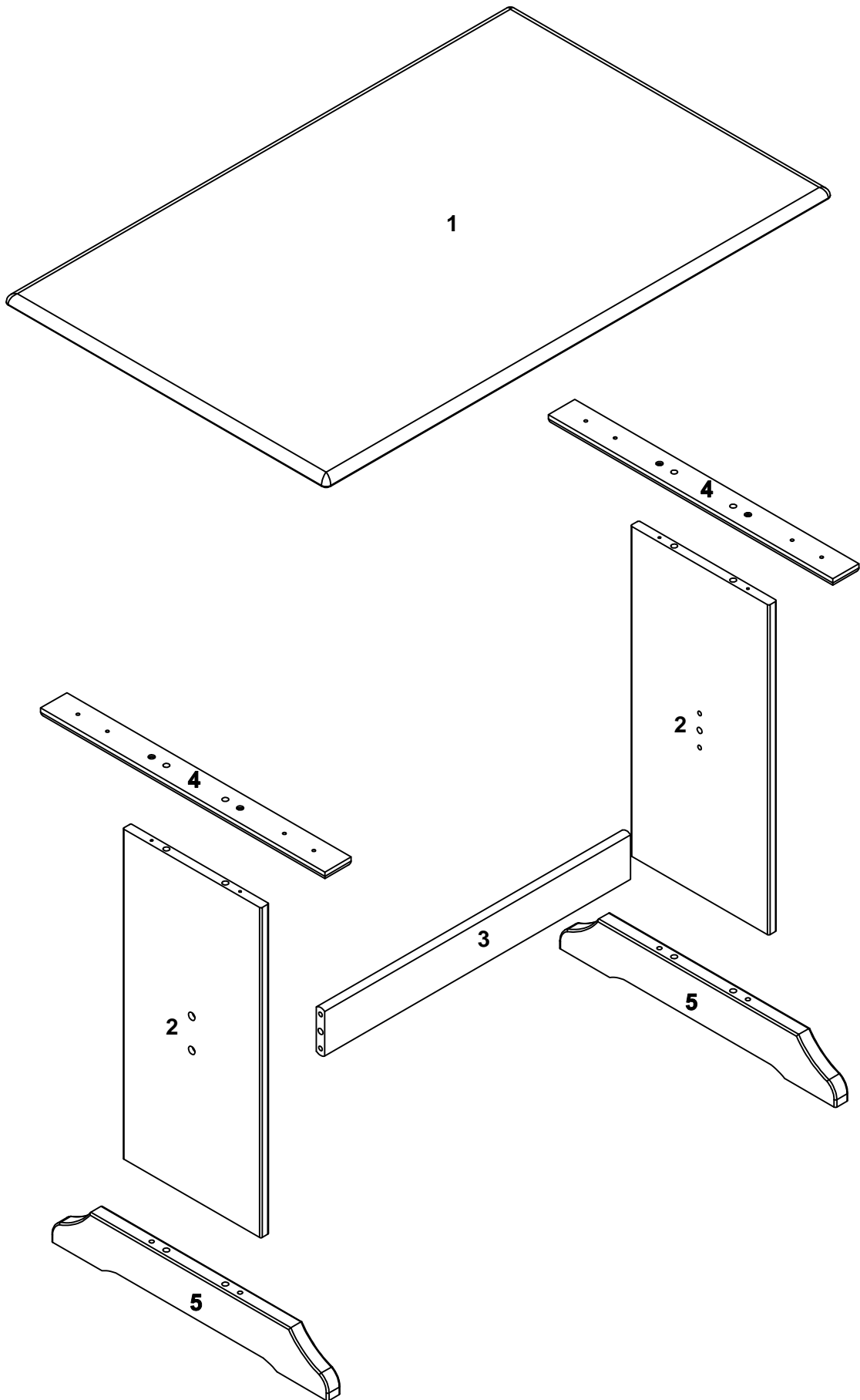

# STEP 1

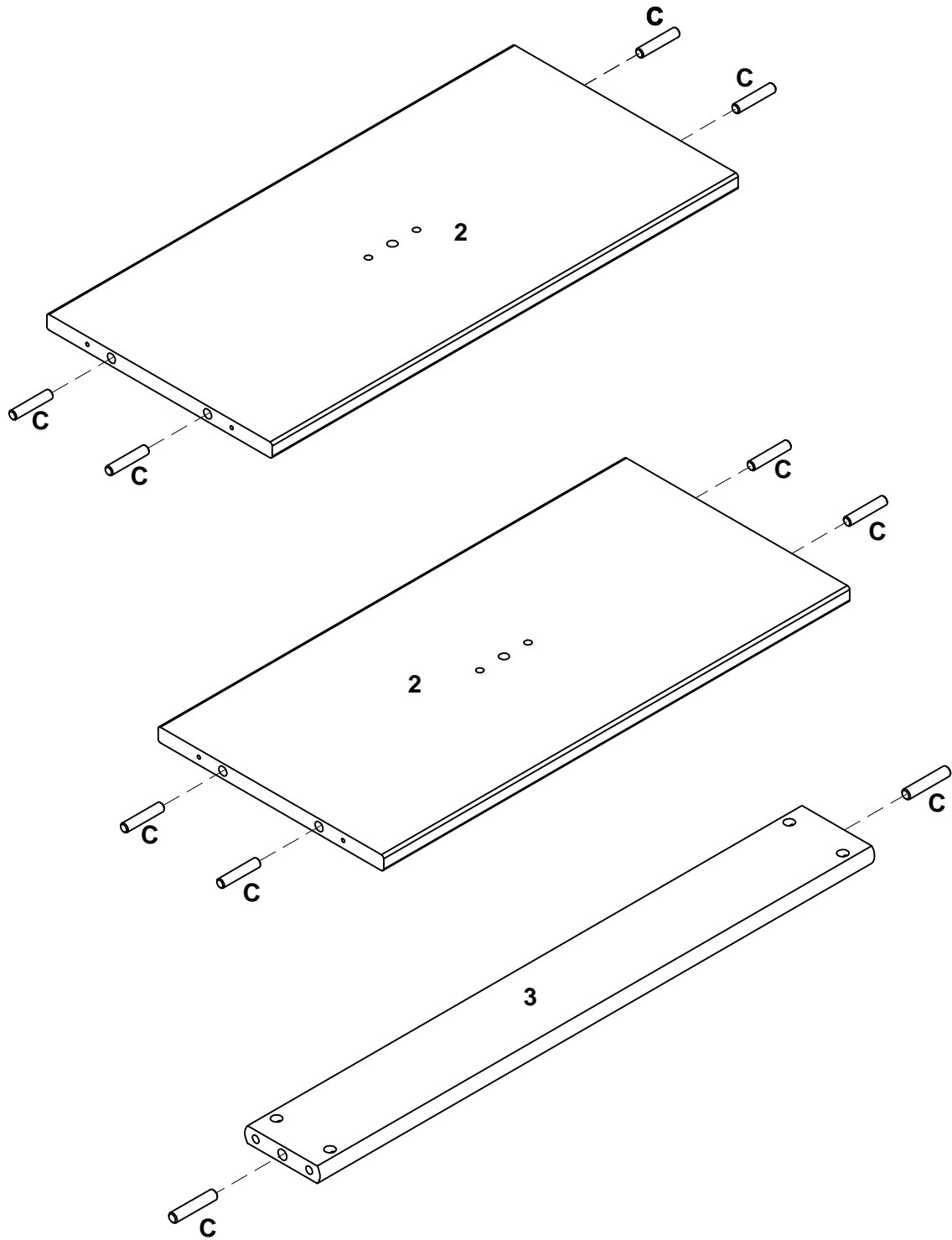

Lay Leg Panel (2) and Table Cross Bar (3) on a material that does not scratch or damage the parts and insert Wood Dowel (C) into the designated holes as shown.

## STEP 2

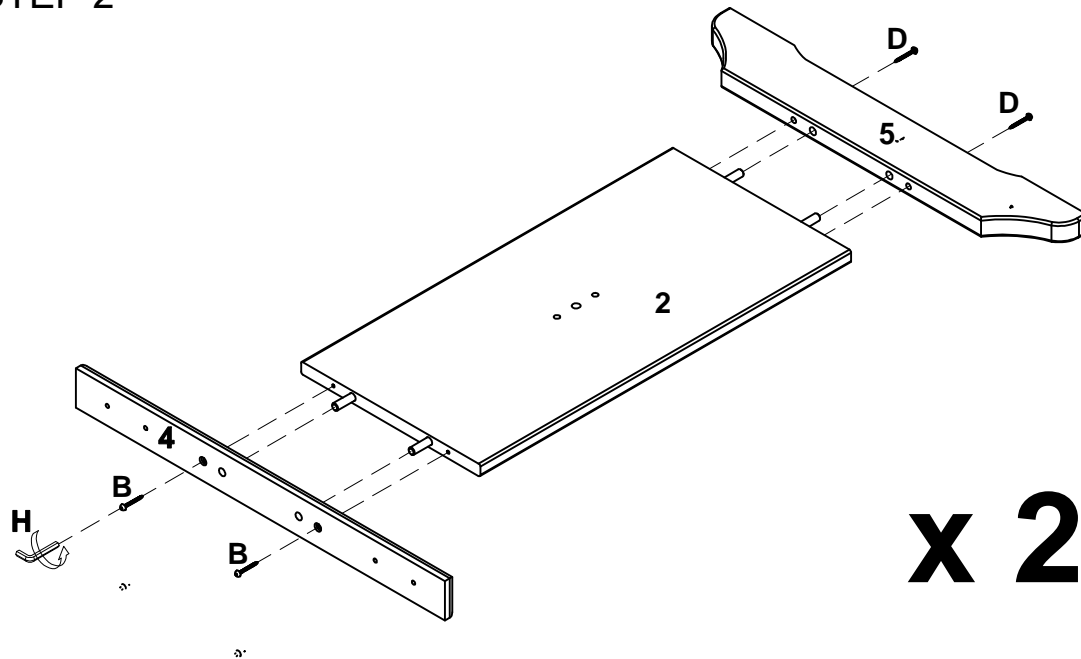

- Attach Table Rail (4) and Leg Base (5) to Leg Panel (2) from STEP 1 via wood dowels on (2).
- Use Screw (B) to fasten (4) and (5) to (2). Use Allen Key (H) to drive and tighten (B).

## STEP 3

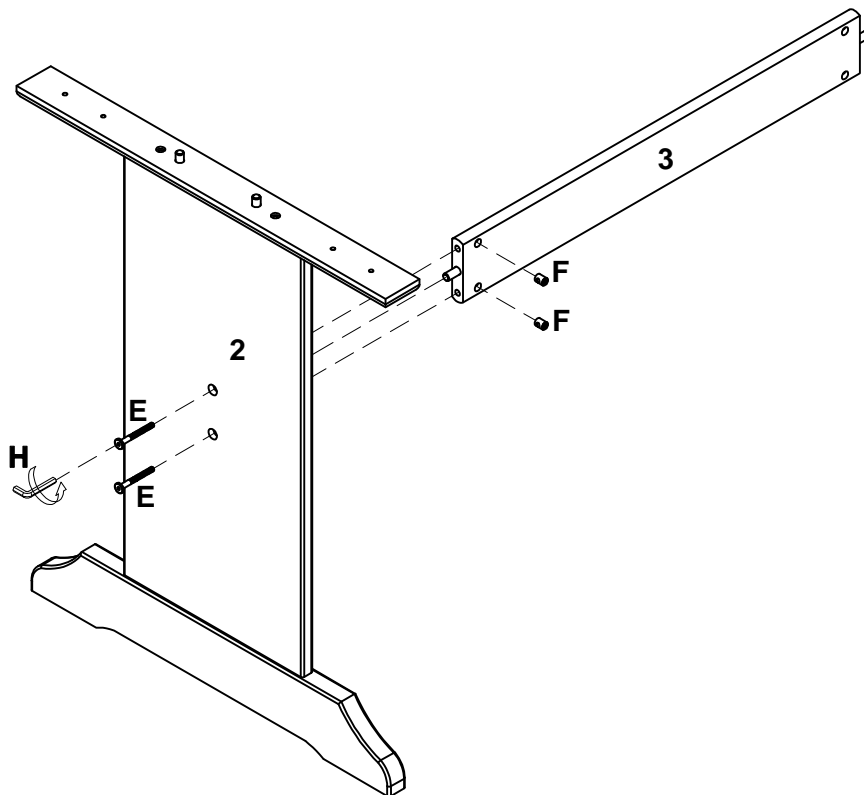

- Set Leg Panel assembly from STEP 2 vertically as shown.
- Insert Barrel Nut (F) into designated hole on Table Cross Bar (3). Refer to Page 2 for Instructions on installing Barrel Nut.
- With assistance, attach (3) to Leg Panel (2) via wood dowel on (3). Insert Screw (E) through screw hole on (2) and (3) to screw onto the Barrel Nut on (3). Use Allen Key (H) to drive and tighten (E).

## STEP 4

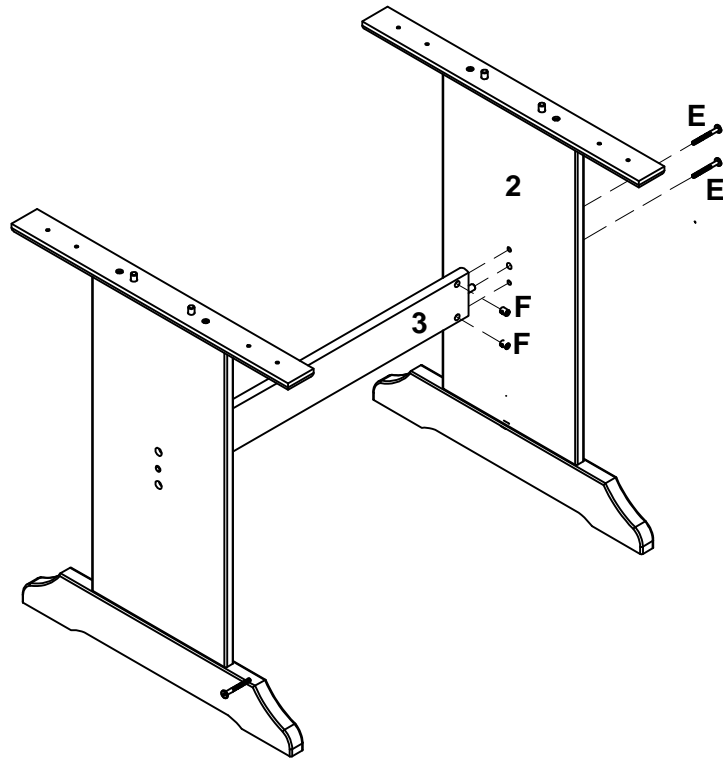

- With assistance, attach the second Leg Panel assembly from STEP 2 to Table Cross Bar (3) via wood dowels on (3)
- Insert Screw (E) through screw hole on (2) and (3) to screw onto the Barrel Nut on (3). Use Allen Key (H) to drive and tighten (E).

---

## STEP 5

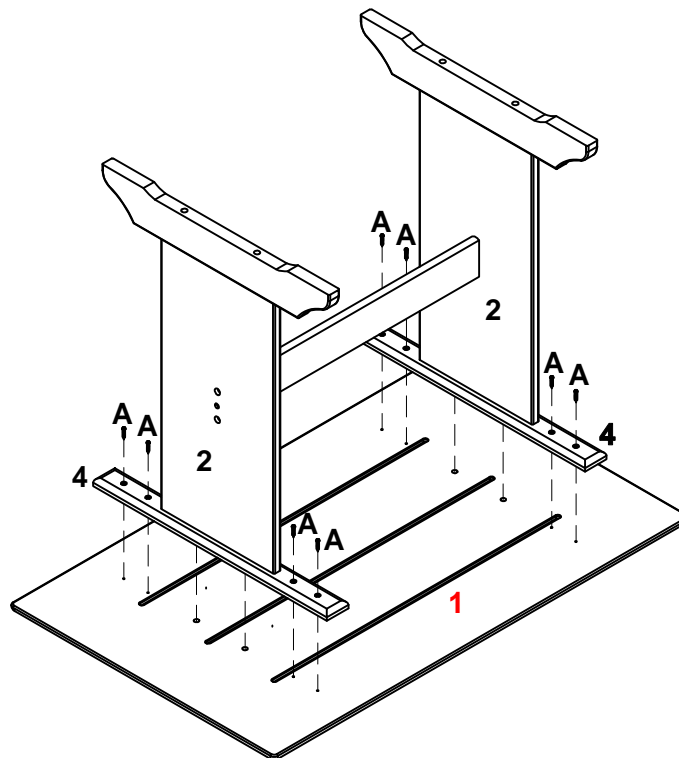

- Lay Table Top (1) bottom-side up on a material that does not scratch or damage the part.
- Attach the assembly from STEP 4 to (1) via wood dowels on Leg Panel (2) protruding through Table Rail (4).
- Use Screw (A) to fasten Table Rail (4) to Table Top (1).
- With assistance, set the table right-side up.

## STEP 6

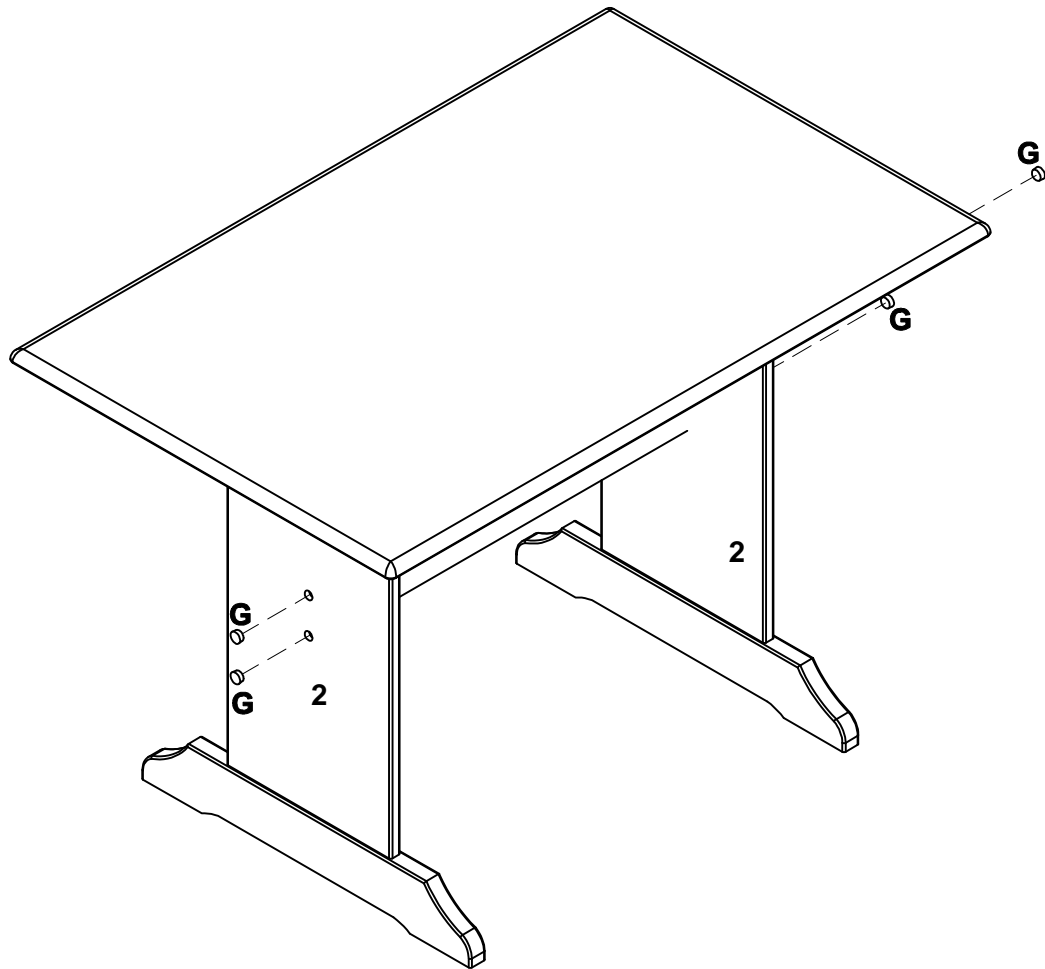

a) Use Cover (G) to conceal screw holes on (2).

The assembly of the table is complete.