

ASSEMBLY INSTRUCTIONS

BAR CHAIR

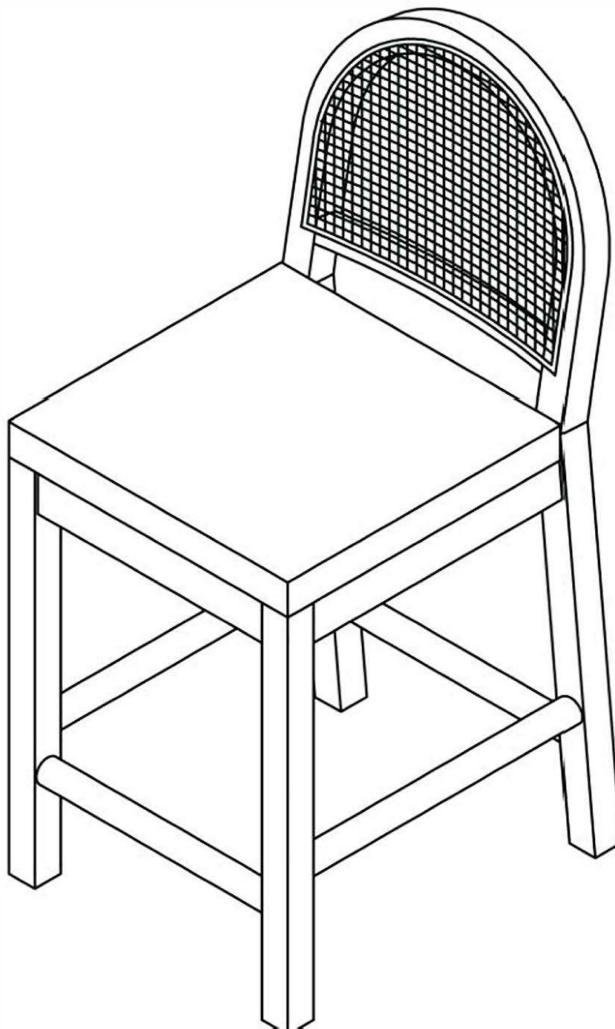

TOOLS REQUIRED



Screwdriver
(Not included)



Allen key
(Included)



2 - People

Enjoying this product? We'd love your 5-star review!
If you have any issues, our support team is happy to help.

Thank you for your purchase

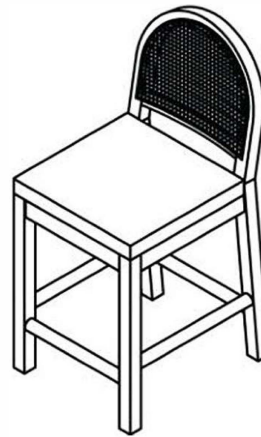

**✓ CHECK
BEFORE STARTING**

Are you missing anything?

Please double check all hardware and parts match the assembly guide before putting the product together. If damaged, we suggest you put the item back in the box and start your claim or return

Should we send any replacements?

If there are any manufacturer defects or missing pieces please contact us for replacements. If purchased online please contact the website of where you purchased it from, DIRECTLY

IMPORTANT INFO before assembly:

If there's a problem with the parts do not attempt to assemble the product

- Place all parts on a clean and smooth surface such as a rug/carpet to avoid parts from being scratched
- When tightening screws to product do not overtighten until product is fully setup
- If product is too heavy for a single person to carry do not attempt and ask for assistance
- DO NOT DRAG or PUSH item to desired location. Must be carried when moving
- If item is not working as intended please review the assembly guide to see if any steps were missed or incorrectly built. If there's a problem with part please contact seller for additional assistance
- Please keep all hardware and small parts away from pets/infants
- Please wear gloves or protective gear to protect from getting cuts
- It is normal for new furniture to have an off gassing smell. Please air out furniture near a window for a few hours or a day before placing it in its desired location
- All products may have a slight color and texture variation due to different shipments, natural materials, screen- resolutions, or lighting in home. Images are rendered by different devices or websites



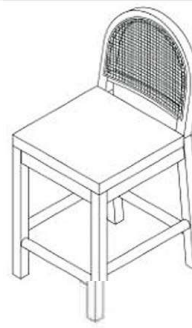

BAR CHAIR

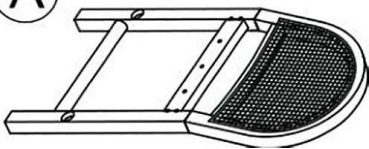
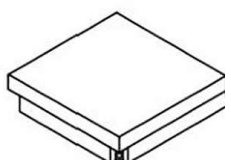
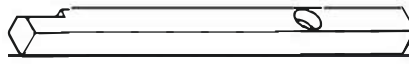
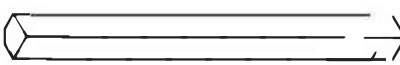
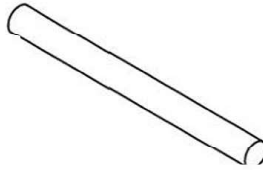
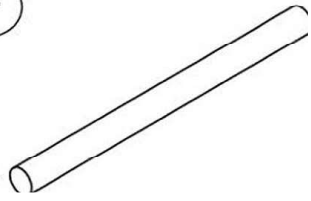

PARTS LIST

<p>A</p>  <p>Chair Back Assembly = 1pc</p>	<p>B</p>  <p>Seat Cushion Assembly =1pc</p>	<p>C</p>  <p>Left Front Leg =1pc</p>
<p>D</p>  <p>Right Front Leg=1pc</p>	<p>E</p>  <p>Front Footrest=1pc</p>	<p>F</p>  <p>Side Stretchers=2pcs</p>

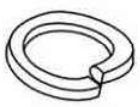
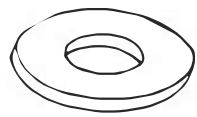
HARDWARE LIST

<p>1</p>  <p>1/4" x 38mm Hex Button Head Bolt =2pcs</p>	<p>2</p>  <p>1/4" x 60mm Hex Button Head Bolt=4pcs</p>	<p>3</p>  <p>1/4" x 80mm Hex Button Head Bolt=4pcs</p>
<p>4</p>  <p>1/4" Lock Washer=10pcs</p>	<p>5</p>  <p>1/4" Flat Washer =10pcs</p>	<p>6</p>  <p>M4*38MM Philips-Head Screw =6pcs</p>
<p>7</p>  <p>Allen Key K4 =1pc</p>		

BAR CHAIR

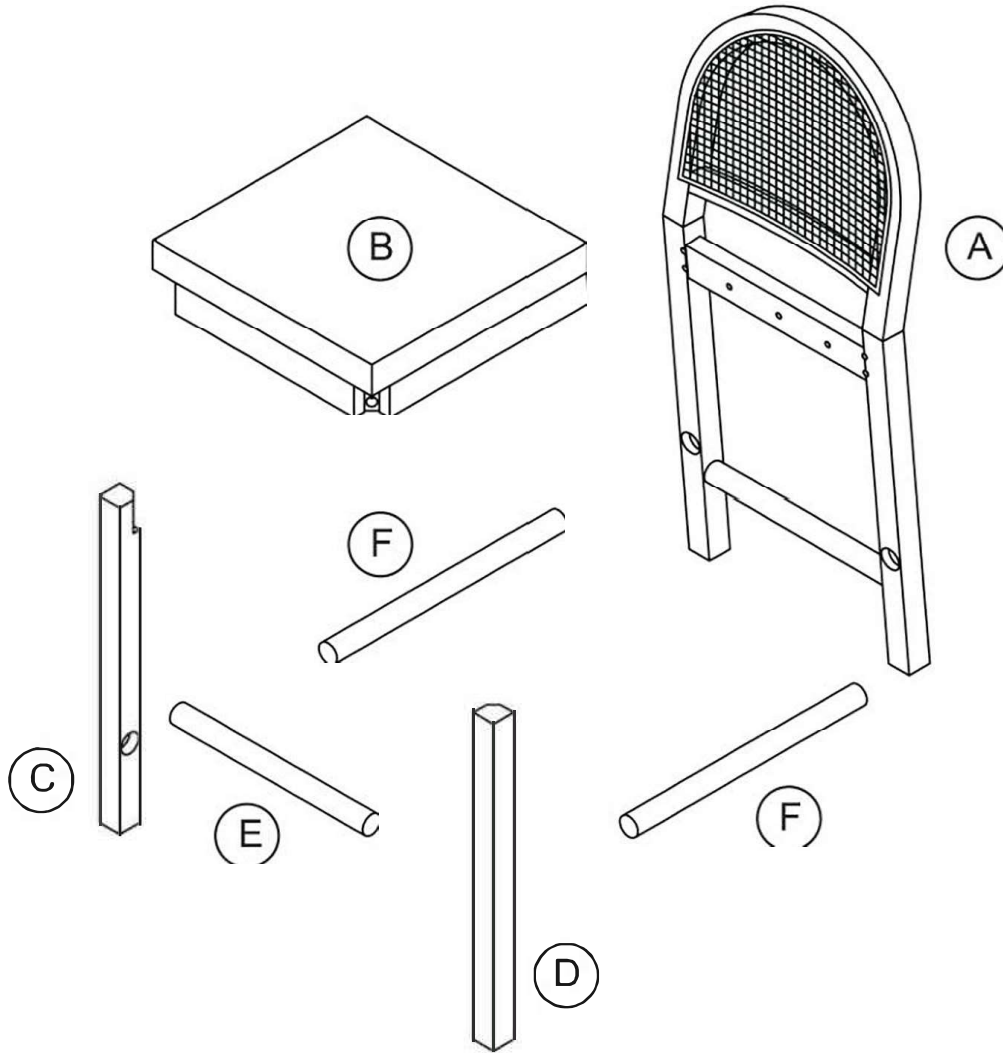
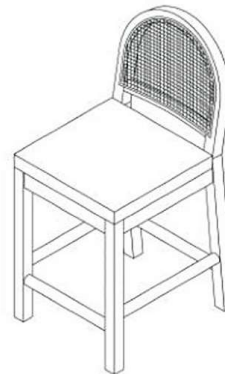

1. Do not tighten bolts / screws completely until all bolts / screws are lined up and inserted into holes.
2. Do not over tighten screws and bolts to avoid stripping.
3. Please use hand tools to assemble this product.





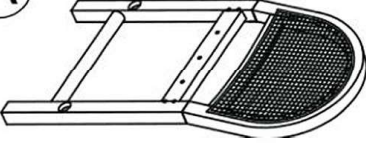
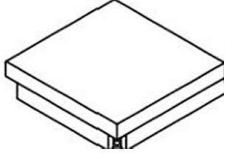
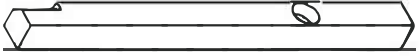
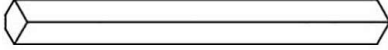
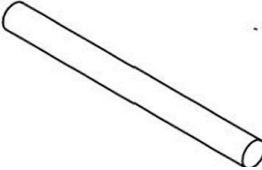
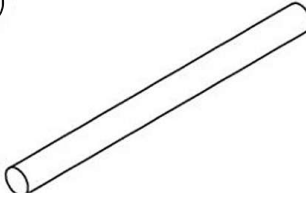

PARTS

check that you've received all parts listed below

PARTS LIST

<p>A</p>  <p>Chair Back Assembly = 1pc</p>	<p>B</p>  <p>Seat Cushion Assembly = 1pc</p>	<p>C</p>  <p>Left Front Leg = 1pc</p>
<p>D</p>  <p>Right Front Leg=1pc</p>	<p>E</p>  <p>Front Footrest=1pc</p>	<p>F</p>  <p>Side Stretchers=2pcs</p>

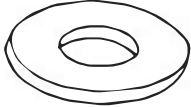
HARDWARE LIST

<p>1</p>  <p>1/4" x 38mm Hex Button Head Bolt =2pcs</p>	<p>2</p>  <p>1/4" x 60mm Hex Button Head Bolt=4pcs</p>	<p>3</p>  <p>1/4" x 80mm Hex Button Head Bolt=4pcs</p>
<p>4</p>  <p>1/4" Lock Washer=10pcs</p>	<p>5</p>  <p>1/4" Flat Washer =10pcs</p>	<p>6</p>  <p>M4x38MM Philips-Head Screw =6pcs</p>
<p>7</p>  <p>Allen Key K4 =1pc</p>		

Step 1 Begin securing the Chair Back (A) to the Seat Cushion Frame (B) using the 1/4 inch Flat Washer (5), 1/4 inch Lock Washer (4) and 1/4 x 1 1/2 inch Hex Button Head Bolt (1).

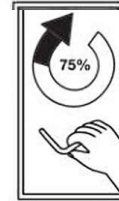
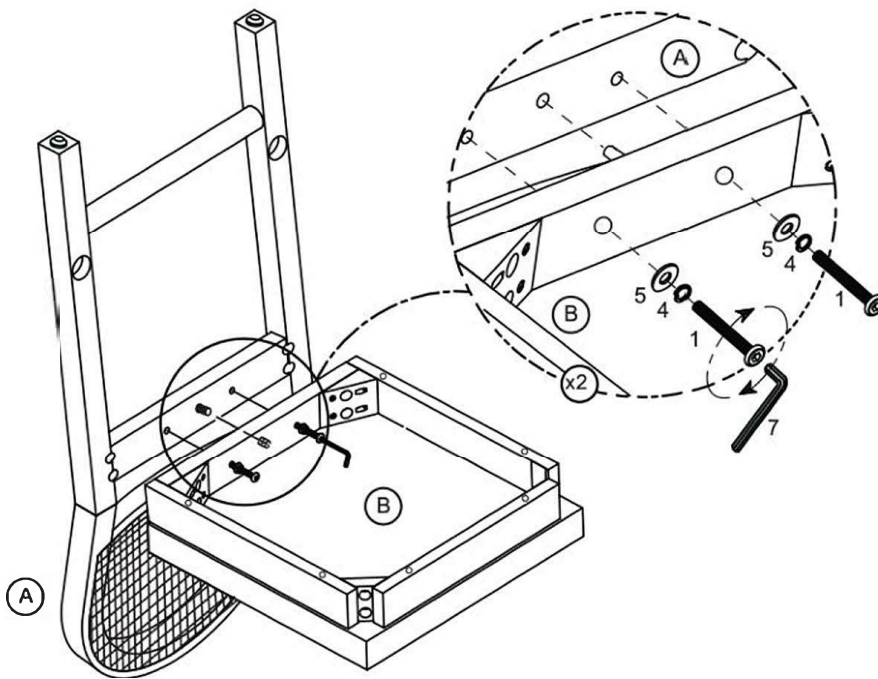

Do NOT overtighten hardware.
Tighten only to 75% for now.

Step 2

Finish securing the Chair Back (A) to the Seat Cushion Frame (B) using the Flat Washers (5), Lock Washers (4) and 1/4 x 3 1/8 inch Hex Button Head Bolts (3).

Tighten to 75% using the Allen Key (7).

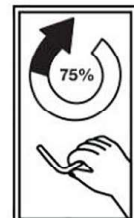
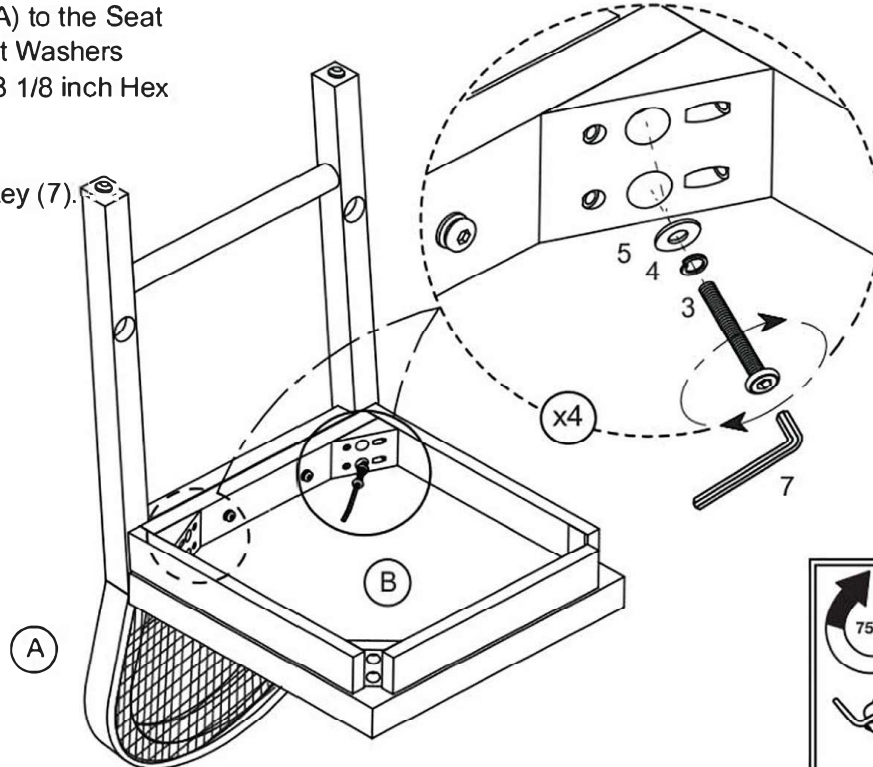

Do not overtighten hardware.
Tighten to 75% for now.

Step 3

Next, attach the Front Legs (C) & (D) to the Seat Cushion Assembly (B) using the 1/4" x 60mm Hex Button Head Bolt (2), 1/4" Lock Washer (4) & 1/4" Flat Washer (5).

Do not overtighten hardware.
Tighten to 75% for now.

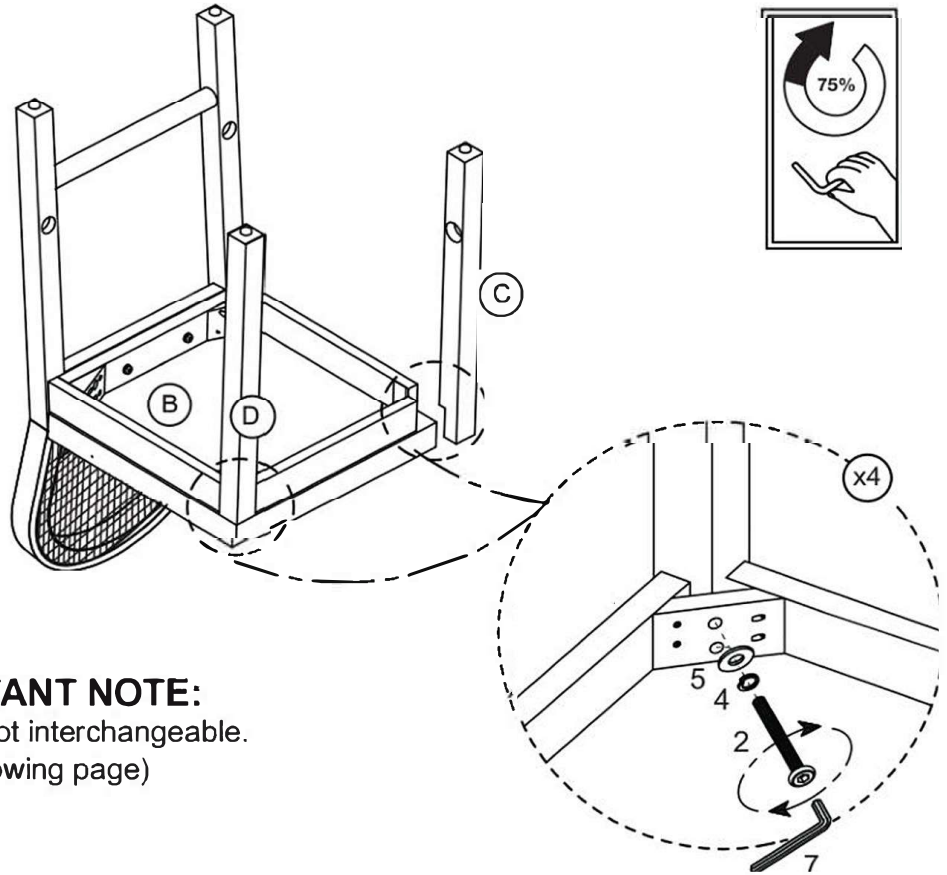

IMPORTANT NOTE:

Front Legs are not interchangeable.
(see following page)

Step 4

Now, screw on the Front Footrest (E) and Side Stretchers (F).

Only two more steps to go!

*If you are having trouble getting the screws to catch, it is recommended to carefully use an electric screwdriver or drill with necessary bit for this step.
Do not over-tighten; holes may become stripped.*

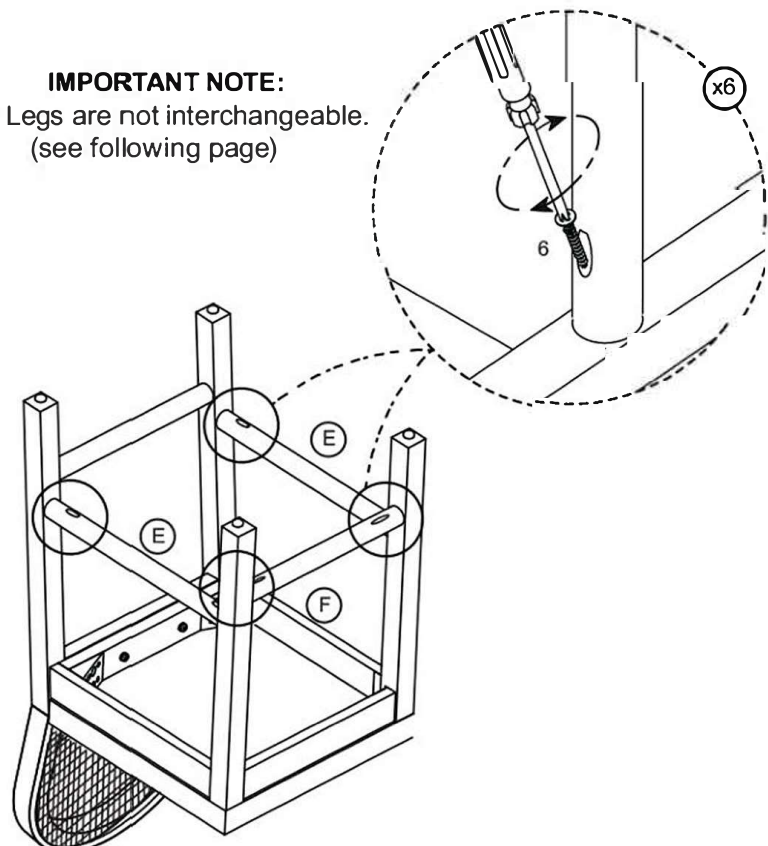

Step 5

Last but not least, flip the stool over on a flat surface & make sure all legs are touching before tightening everything from to 100%

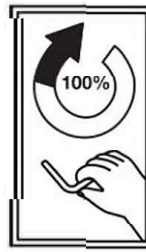

If your stool feels a little wobbly or unstable, re-address all fasteners to ensure they are 100% tightened.

If your stool STILL feels a little wobbly or unstable, try loosening some of the fastener connections slightly in order to allow yourself to re-level all the legs on a flat surface before going back around & re-tightening everything back to 100%.

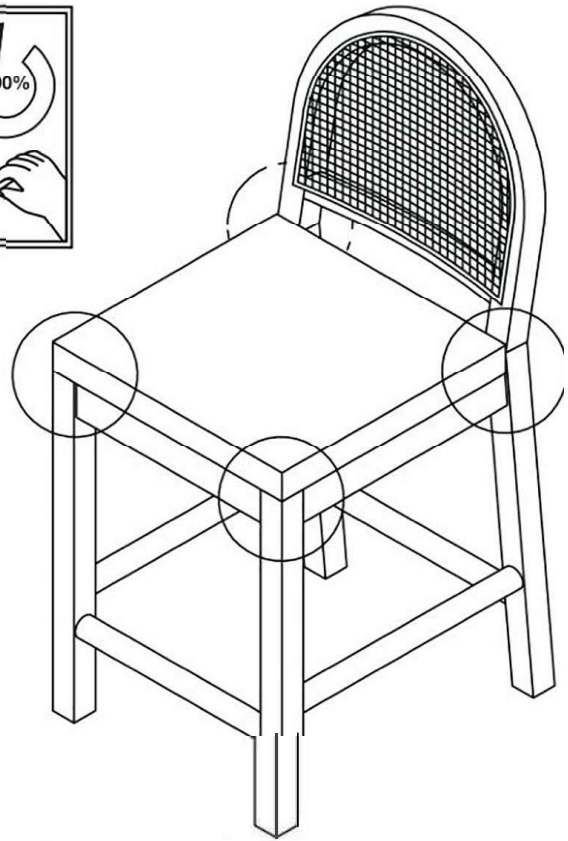

We want your bar stool to last as long as possible, so we recommend that you tighten the screws 2 weeks after assembly and for added safety check the tightness of all screws every 2 months.

Step 6

Lastly, double-check that your stool is level & stable. If it's looking a little unlevel or unstable still, you can adjust the levelers on each of the front legs.

HELPFUL TP:

Adjust the levelers to help balance the stool, if need be.

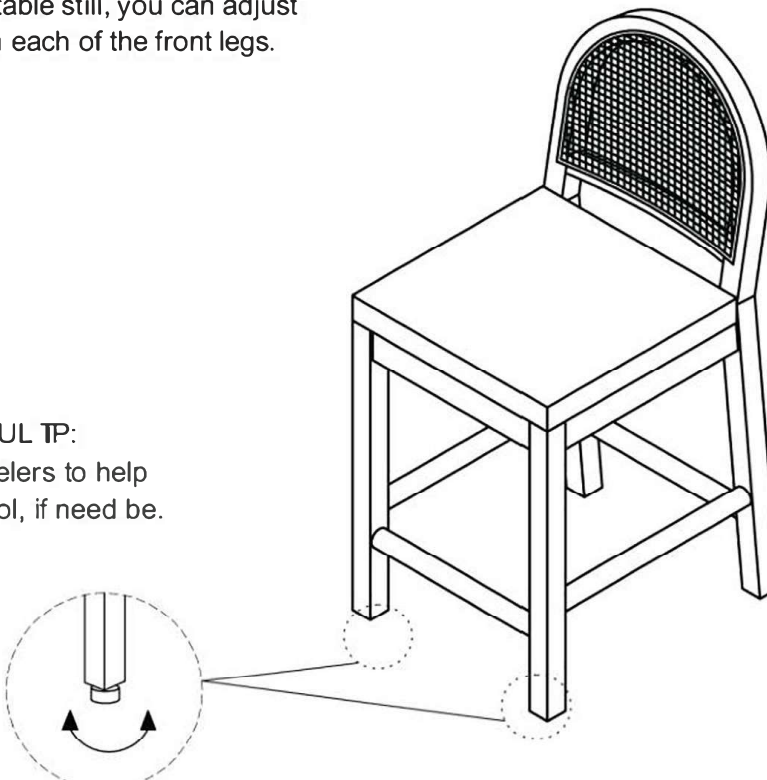

Issues with stretchers aligning at an angle?

If the stretchers are set at an angle when you are aligning them with their respective holes on the front & back legs, **you have likely assembled the front legs incorrectly.**

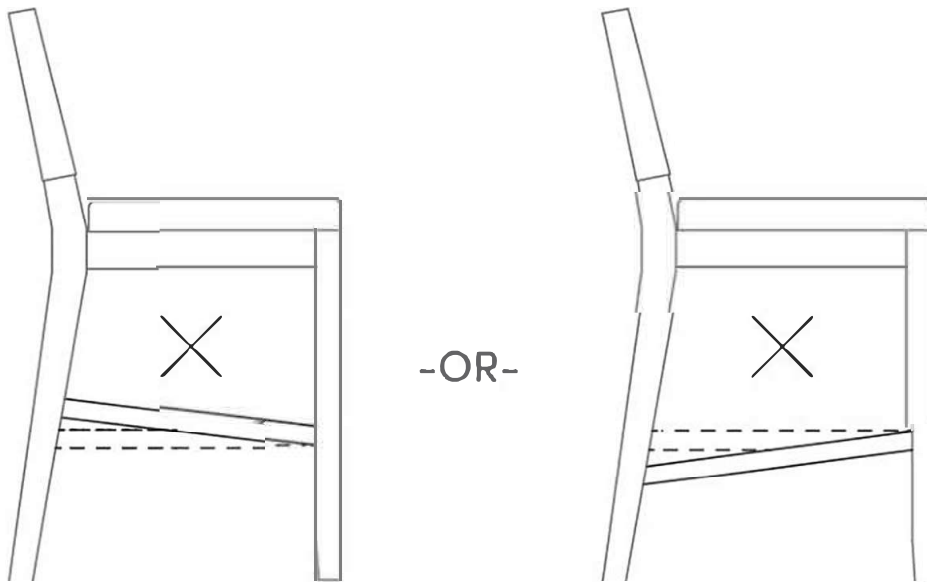

Re-check to confirm that the proper legs are installed in their intended position on the proper side of the stool.

The front legs are not interchangeable; therefore they may need to be rotated and swapped to the opposite side.

