

# Assemble Instruction

---

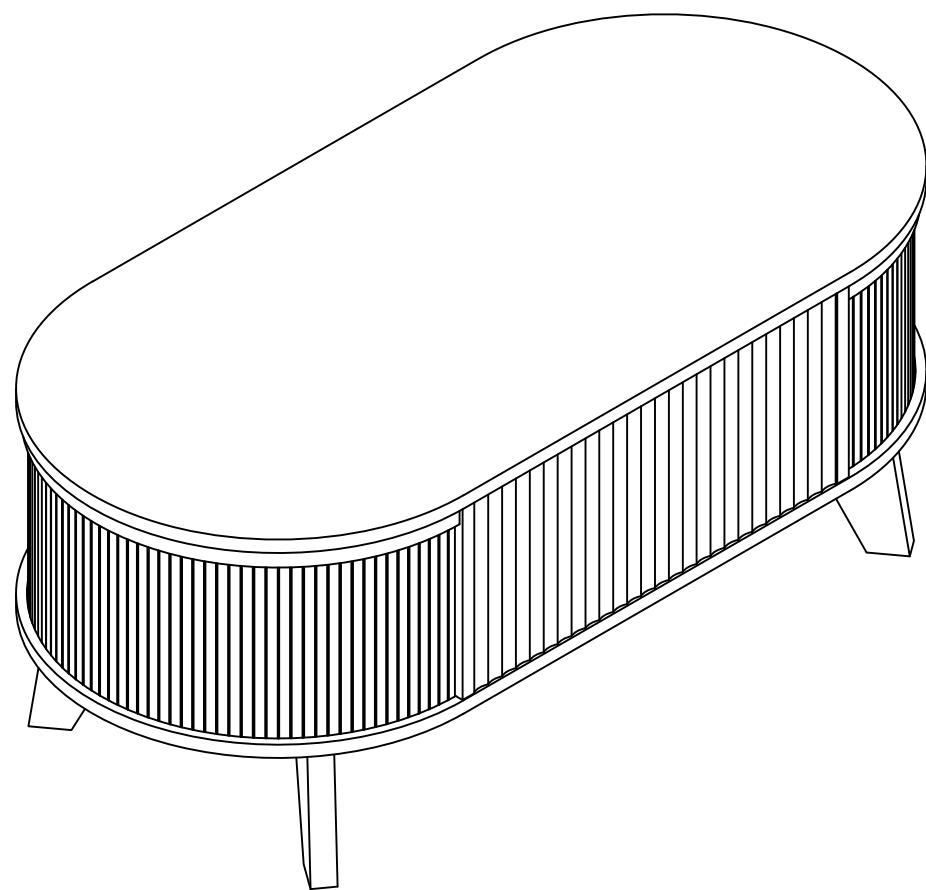

As this item contains many parts, please read the installation instruction carefully before installation and complete the installation with the cooperation of your partner. Please use tools properly and carefully. If you have any questions about the product and installation, please contact us.

# Before You Start

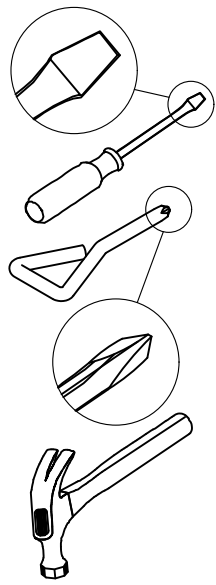

- ✓ Read through each step carefully and follow the proper order
- ✓ Separate and count all your parts and hardware
- ✓ Give yourself enough room for the assembly process
- ✓ Have the following tools: Flat Head Screwdriver, #2 Phillips Head Screwdriver and Hammer
- ✓ Caution: If using a power drill or power screwdriver for screwing, please be aware of to slow down and stop when screw is tight. Failure to do so may result in stripping the screw. (Assembly speed can be increased by using electric screwdriver)

# Helpful Hints

## PEOPLE NEEDED FOR ASSEMBLY: 1-2

- Open your item in the area you plan to keep it to avoid excessive heavy lifting.
- Identify, sort and count the parts before attempting assembly.
- Compression dowels are lightly tapped in with a hammer.
- Slides are labeled with an **R** (right) and **L** (left) for proper placement.
- Make sure to always face the point on the top of the Cam Lock towards the outer edge.
- If there is a back panel in the package, please install it to make sure your unit is complete and sturdy.
- Please fix all the screws provided for the back panel which can enhance product stability. If it is difficult to fix it when tightening, it can be fixed with the help of a hammer and then tightened.
- Do NOT use harsh chemicals or abrasive cleaners on this item.
- Never push, pull, or drag your furniture.

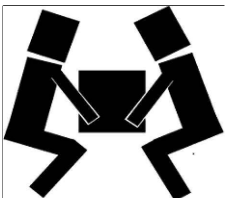
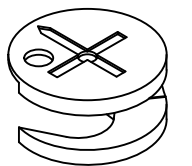
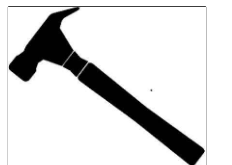
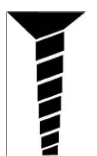
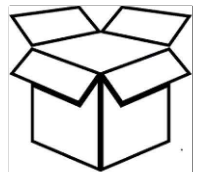

# Board Identification

Not actual size

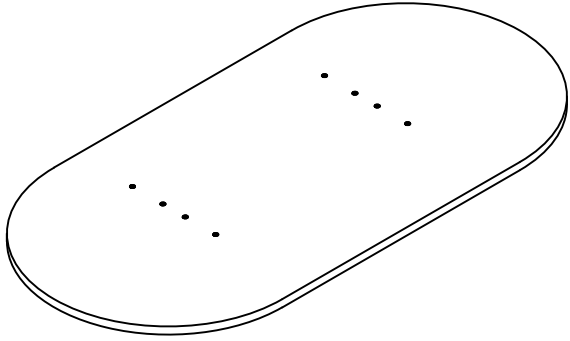

**A**

Qty:1

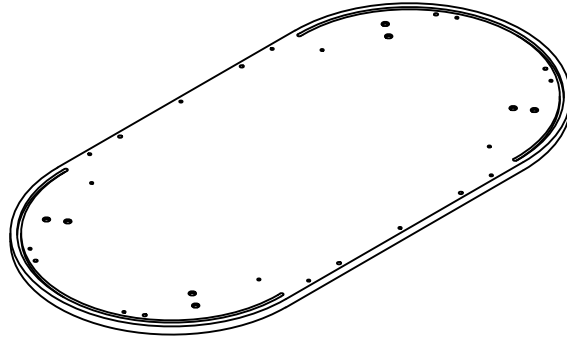

**B**

Qty:1

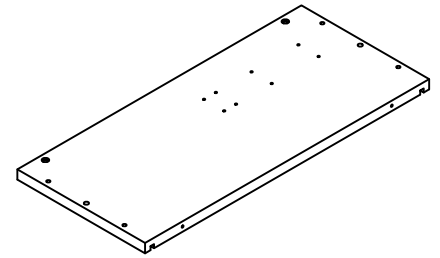

**C**

Qty:1

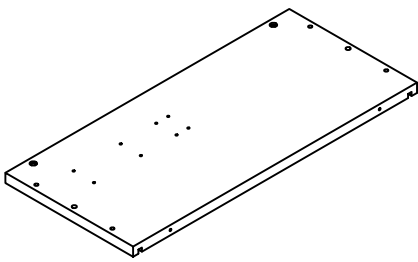

**D**

Qty:1

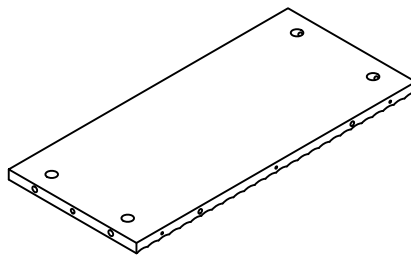

**E**

Qty:2

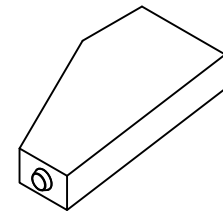

**F**

Qty:4

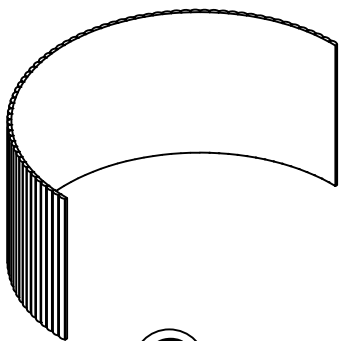

**G**

Qty:2

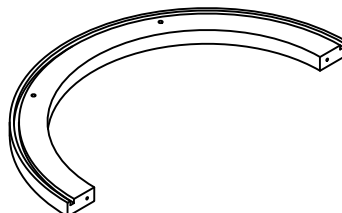

**H**

Qty:2

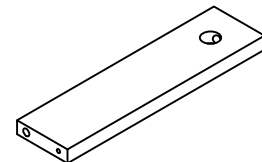

**I**

Qty:4

# Part List

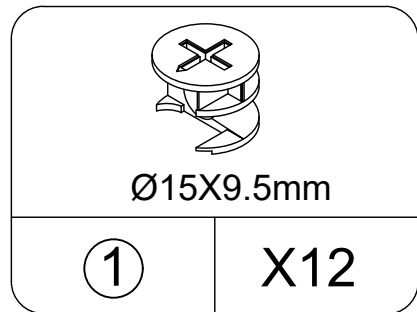

CAM LOCK  
spare:1

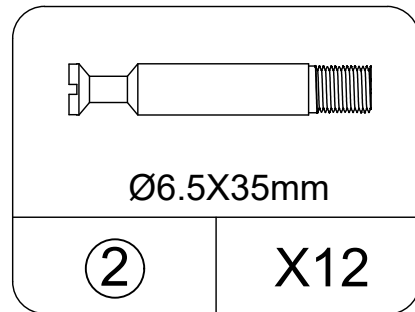

CAM BOLT  
spare:1

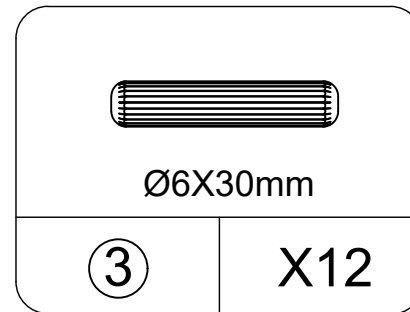

WOOD DOWEL  
spare:1

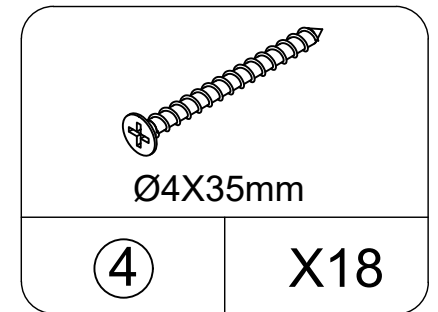

CONFIRMAT SCREWS  
spare:2

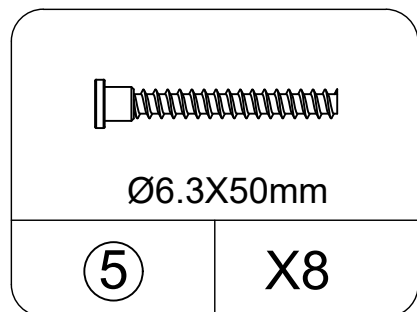

SCREWS  
spare:1

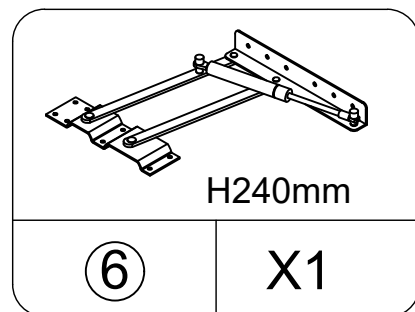

LEFT LIFTING FRAME

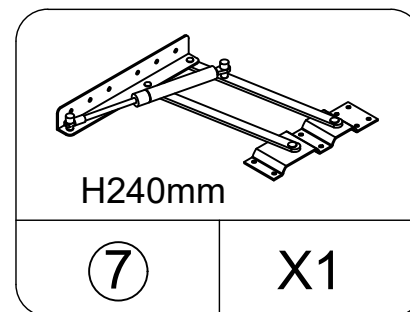

RIGHT LIFTING FRAME

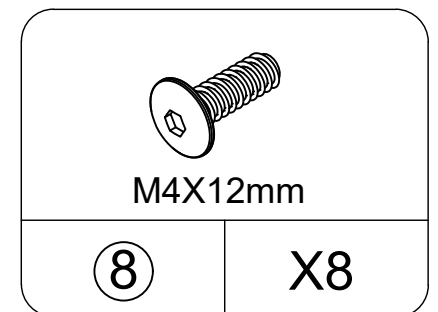

SHELF SUPPORT  
spare:1

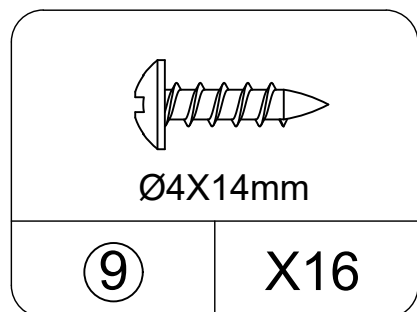

SCREW  
spare:2

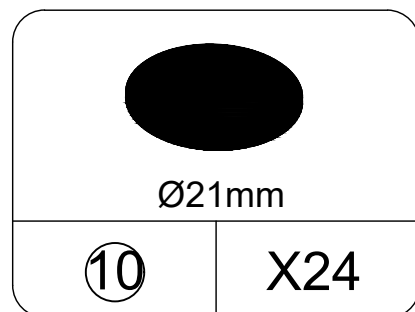

PERFECT STICKER  
spare:2

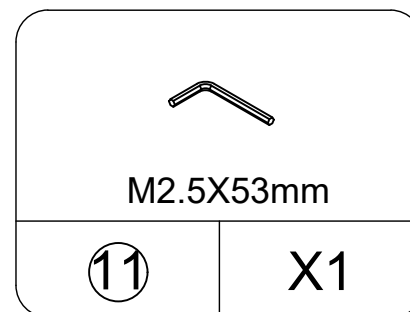

HEX KEY

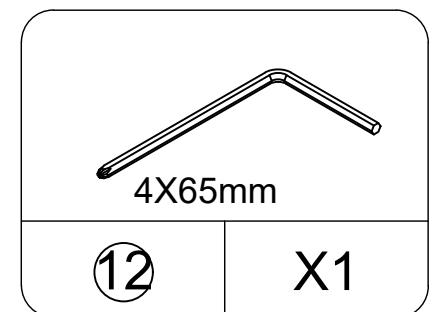

HEX KEY

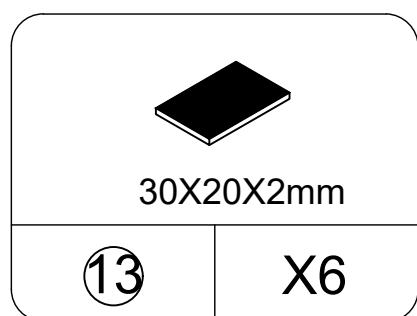

FEIT PAD  
spare:1

# Part List

## Cam Lock Fastening System

Insert the cam bolt into the hole first, then insert the cam lock and lock it.

1

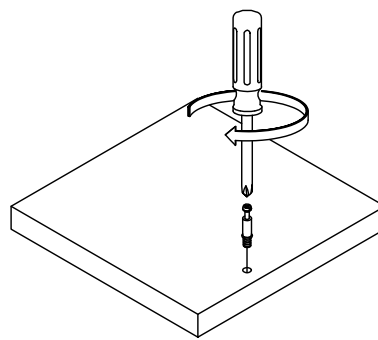

2

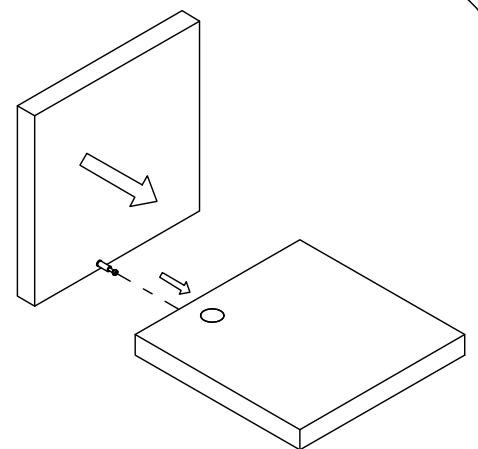

3

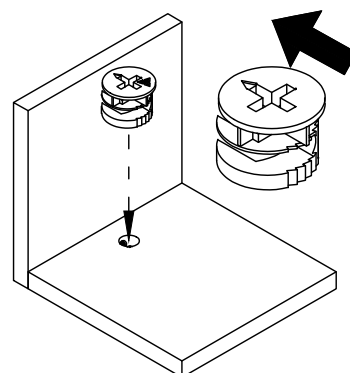

The opening must point toward the edge of the board

4

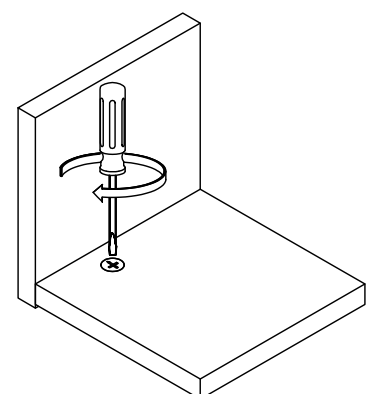

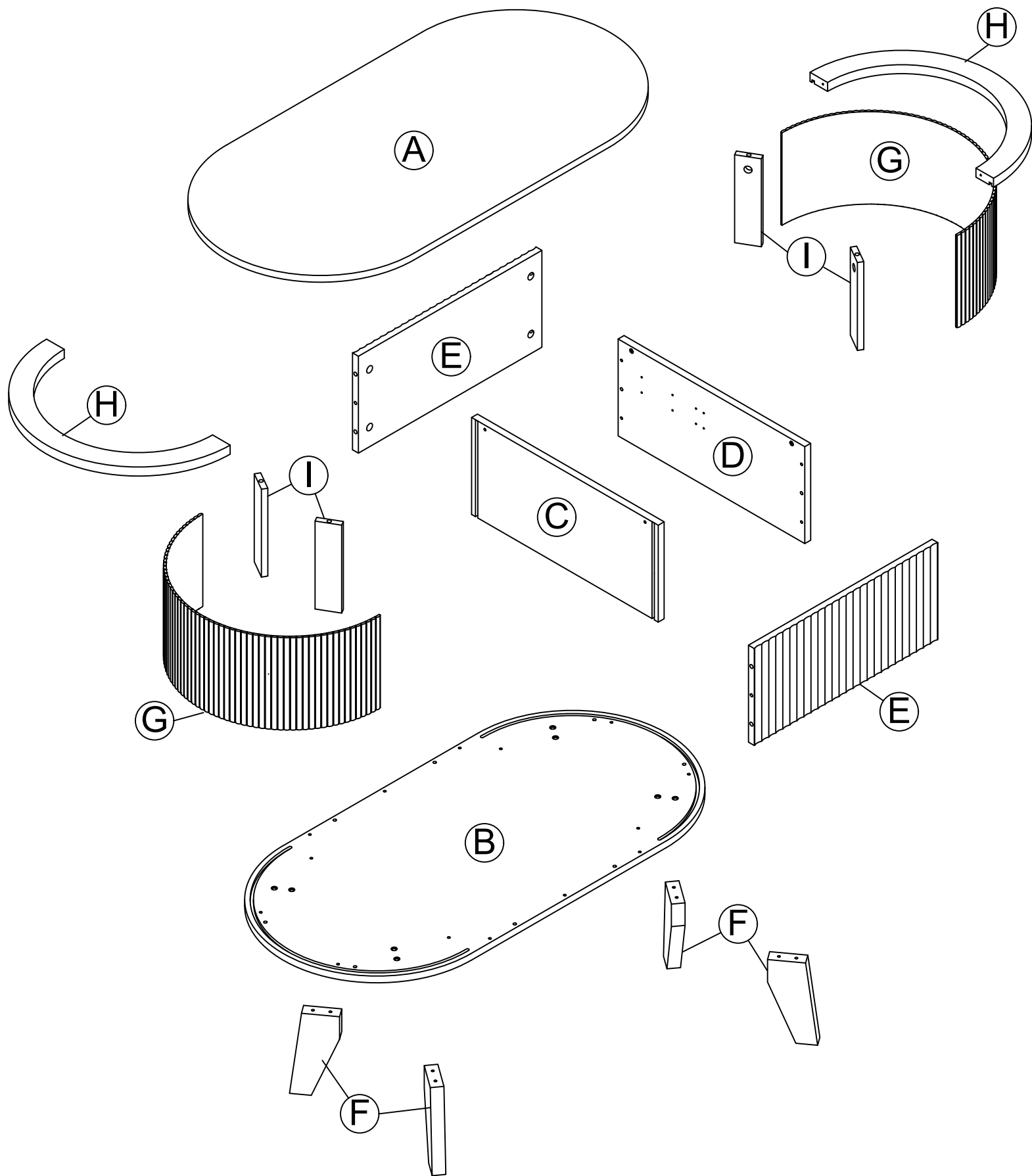

# Board Identification

Not actual size

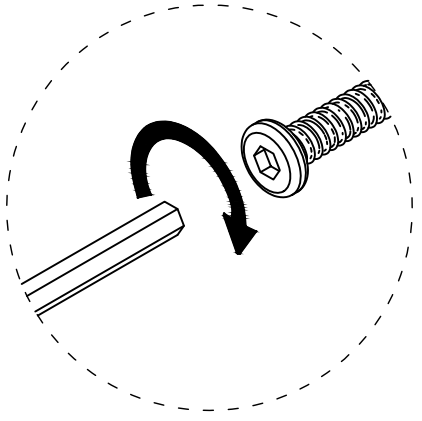

# STEP 1

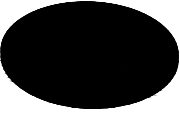

 Ø6.3X50mm	
⑤	X8

 Ø21mm	
⑩	X8

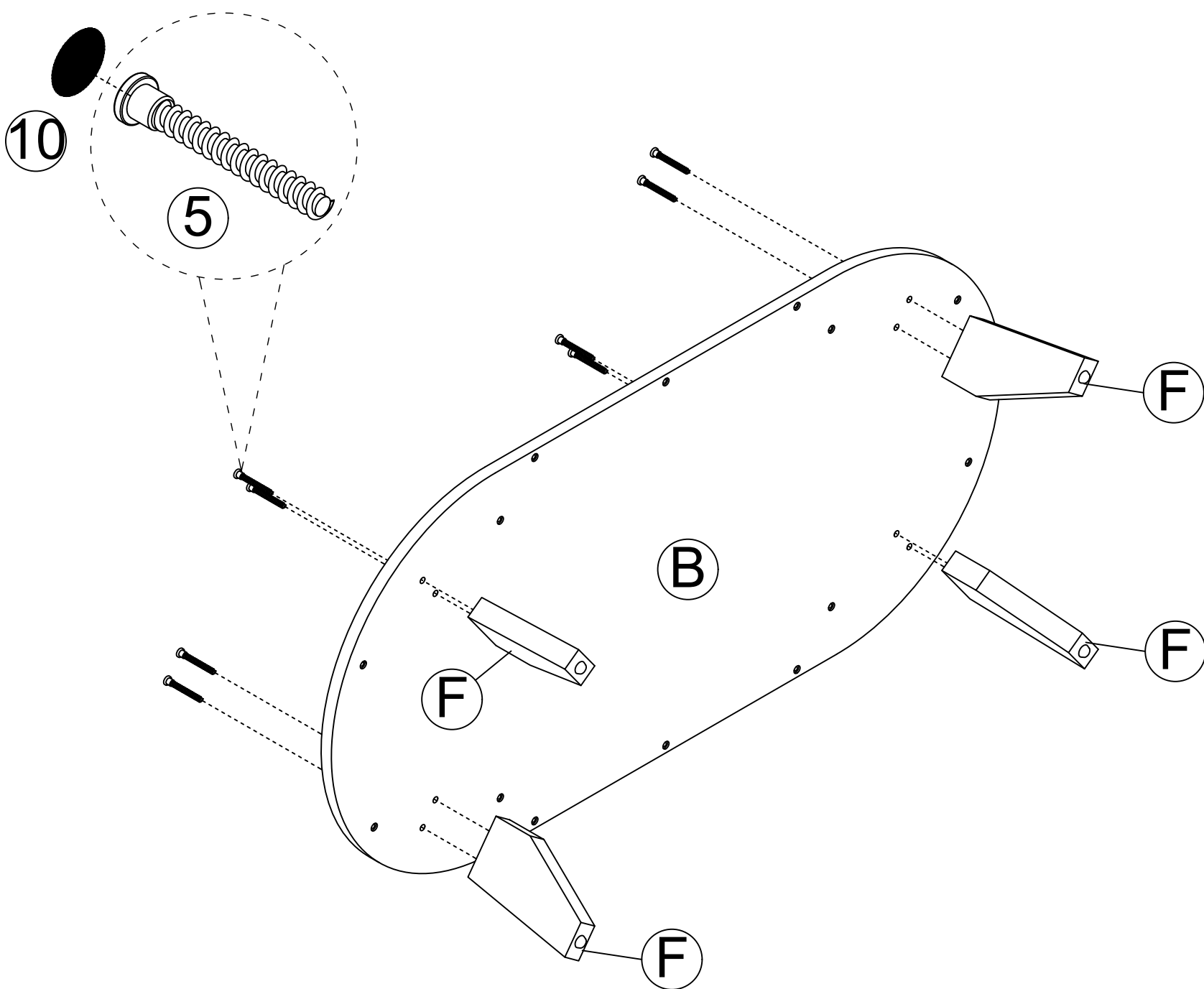

# STEP 2

	
Ø6X30mm	
③	X4

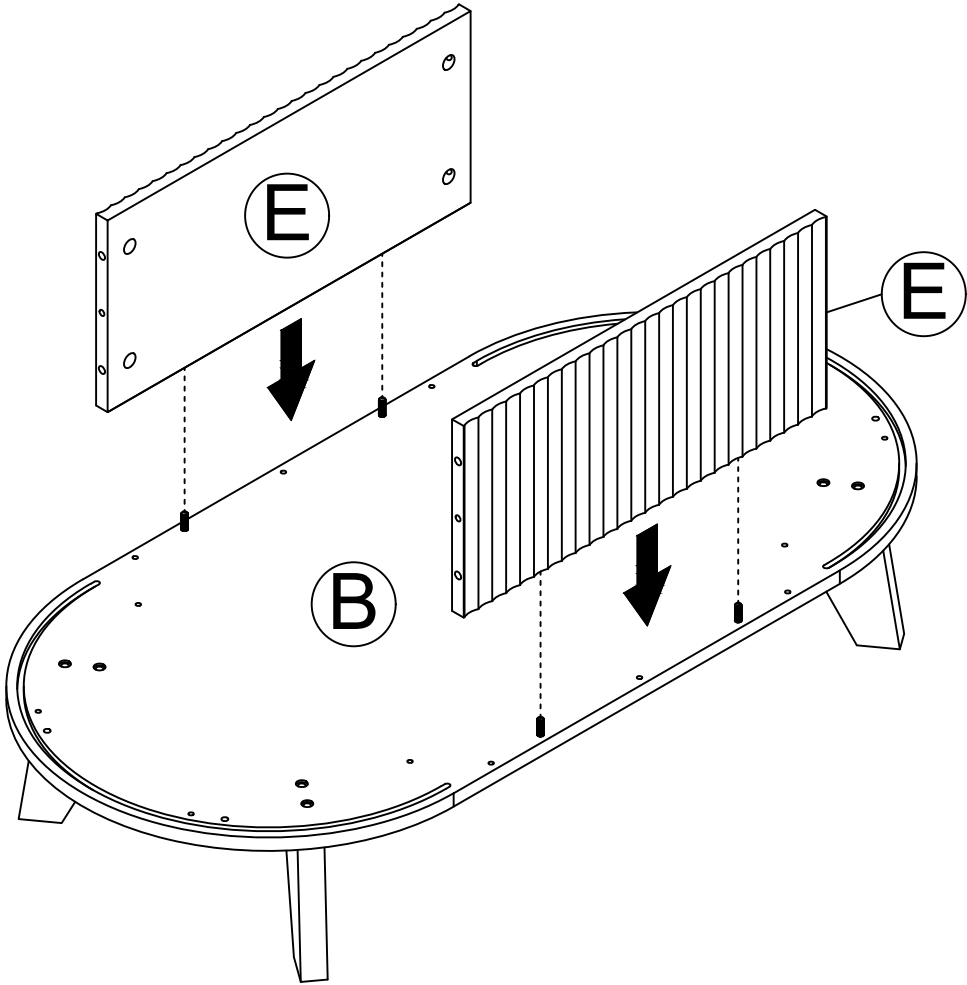
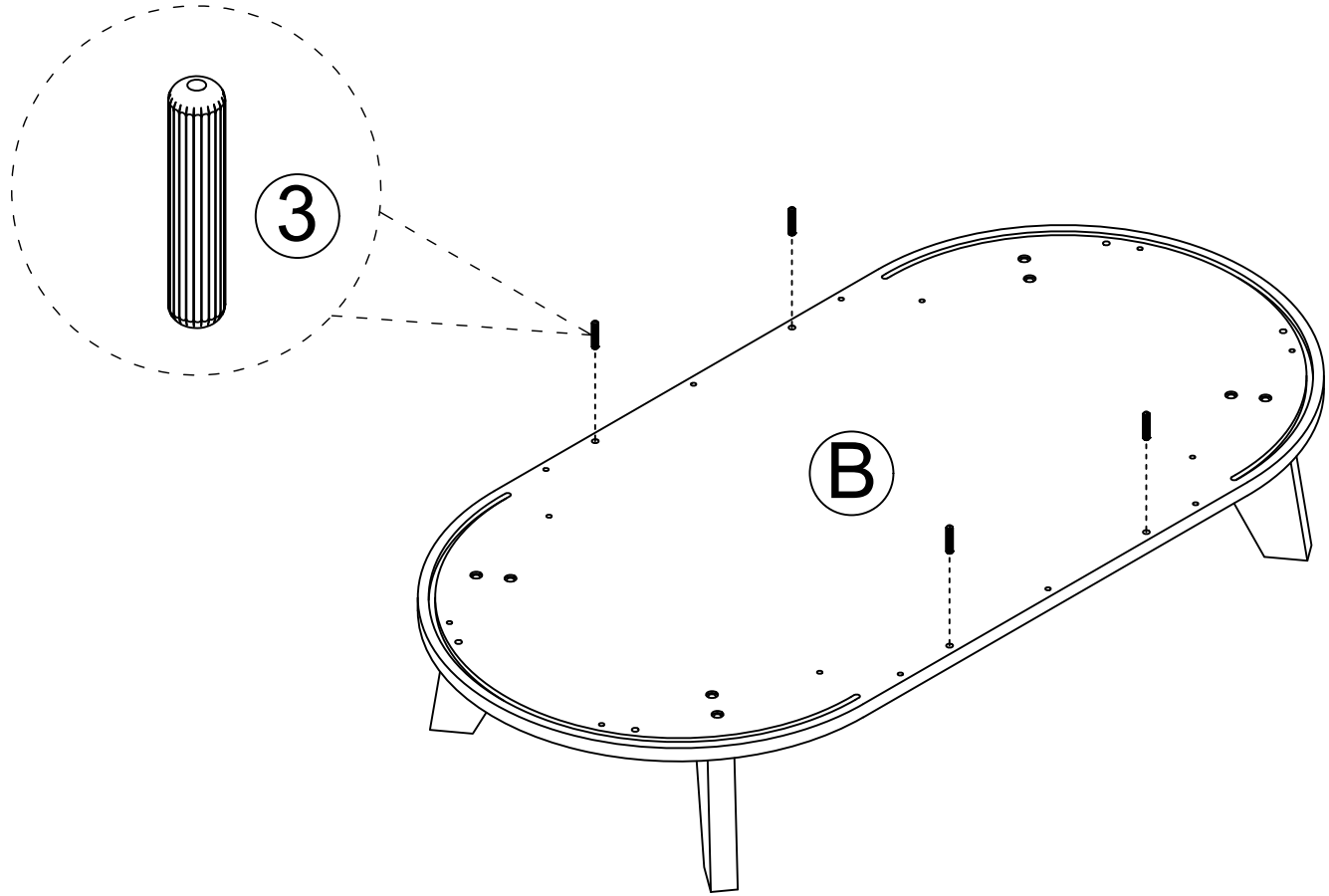

# STEP 3

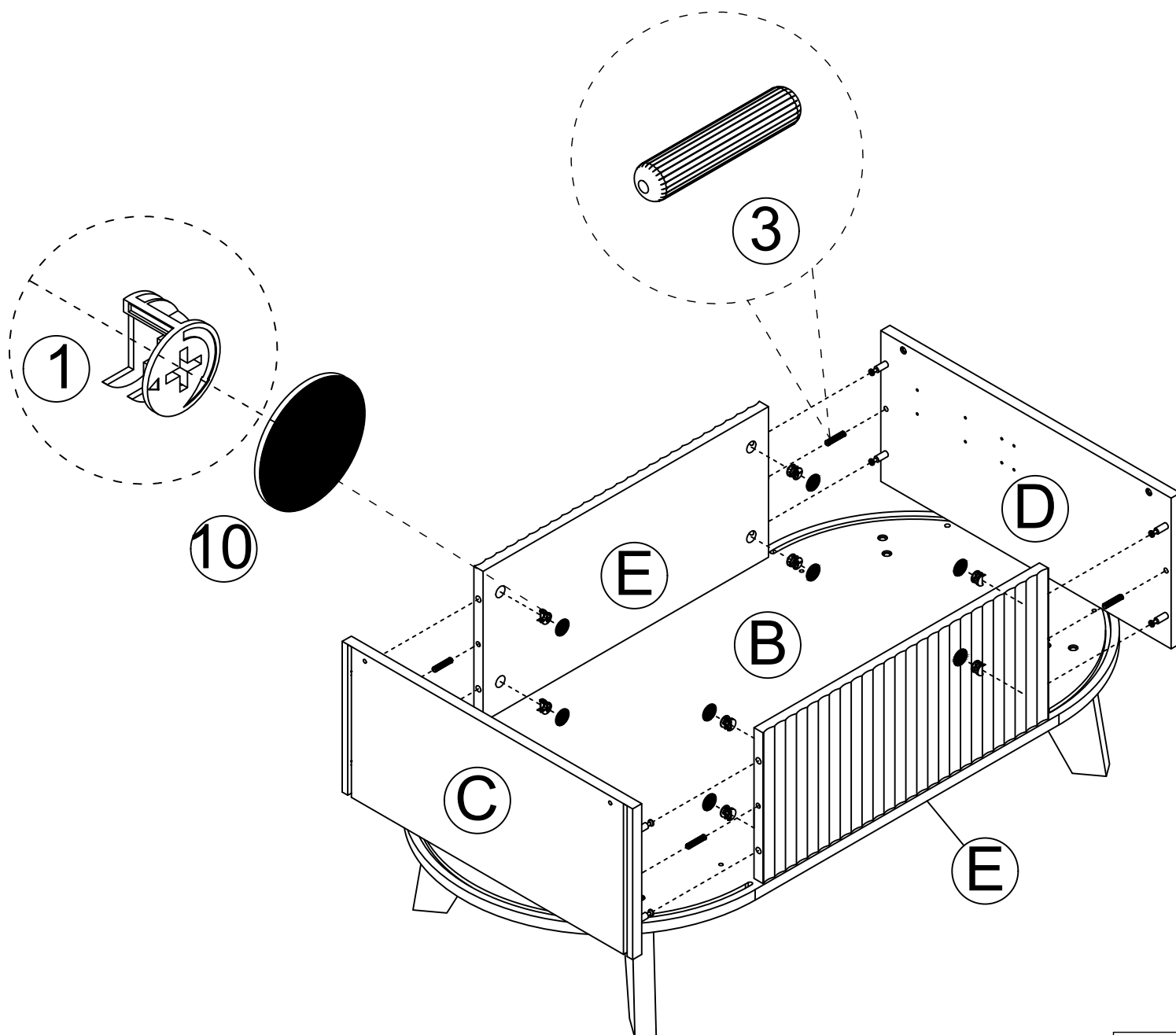
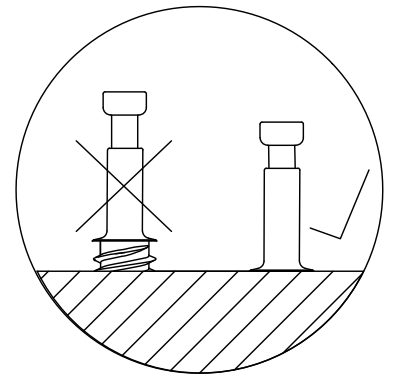
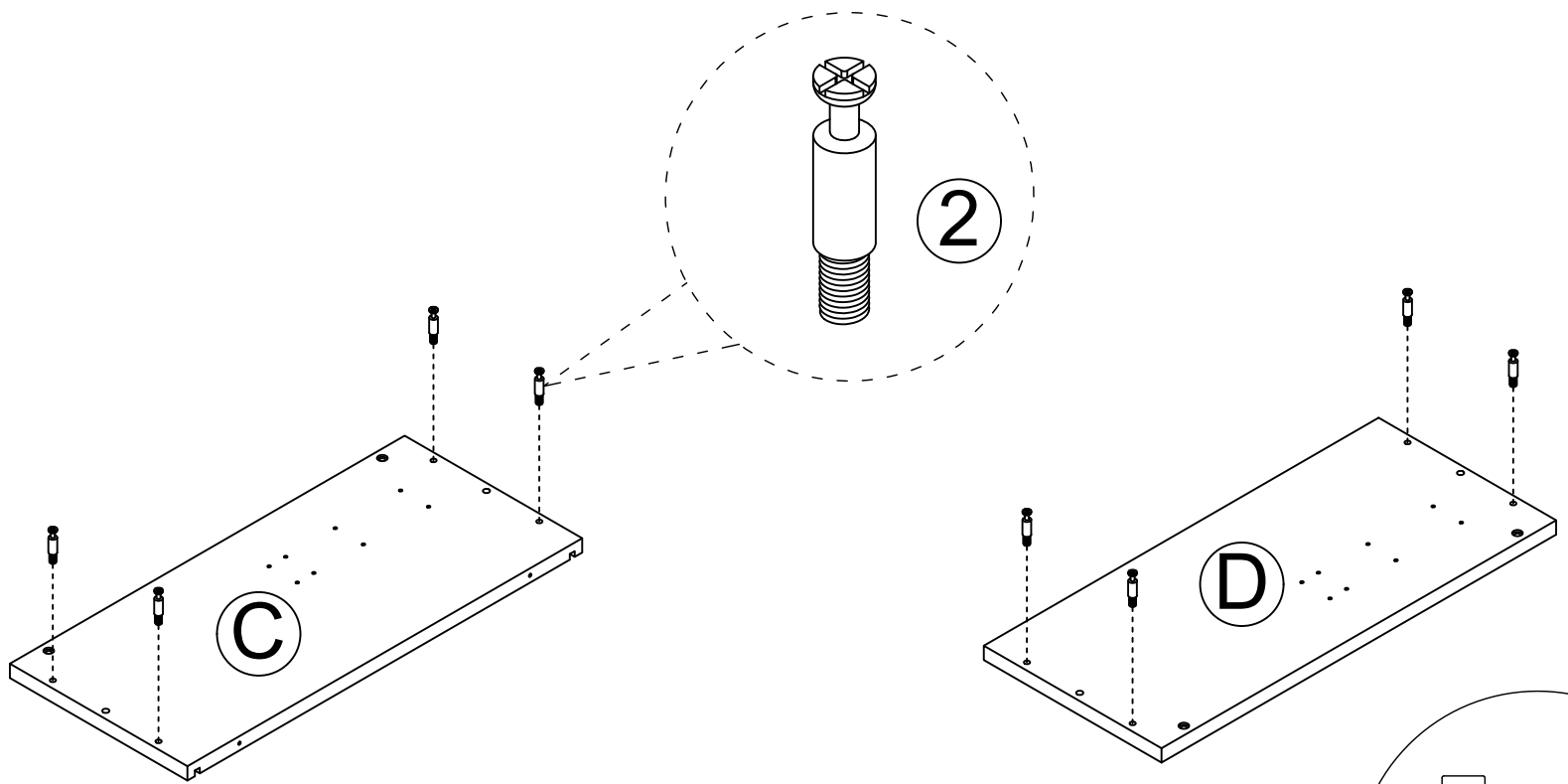
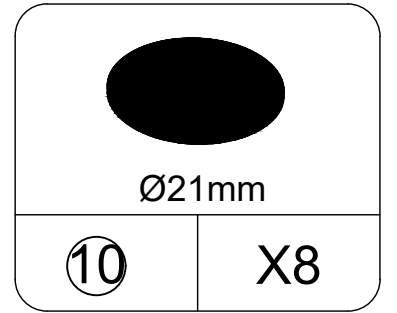
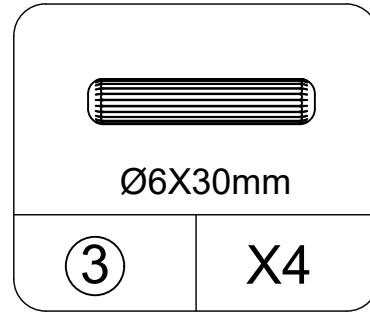
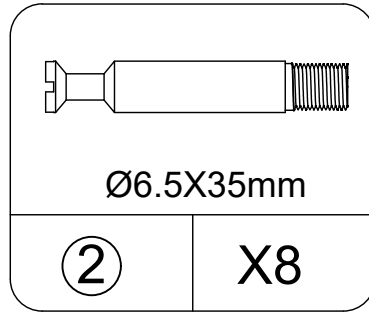
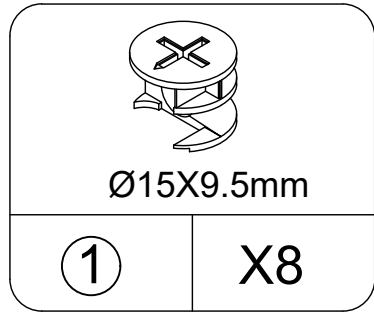
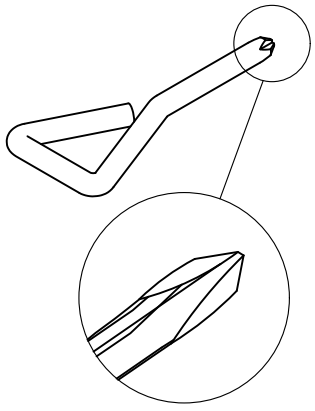

Insert the cam bolt into the hole first, then insert the cam lock and lock it.

# STEP4

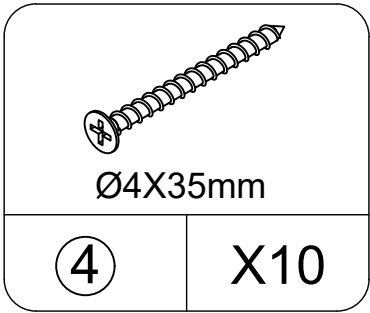
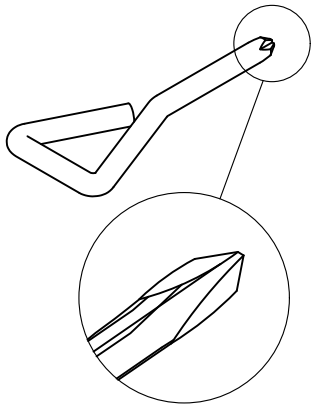

Hold it with your hand and stand up.

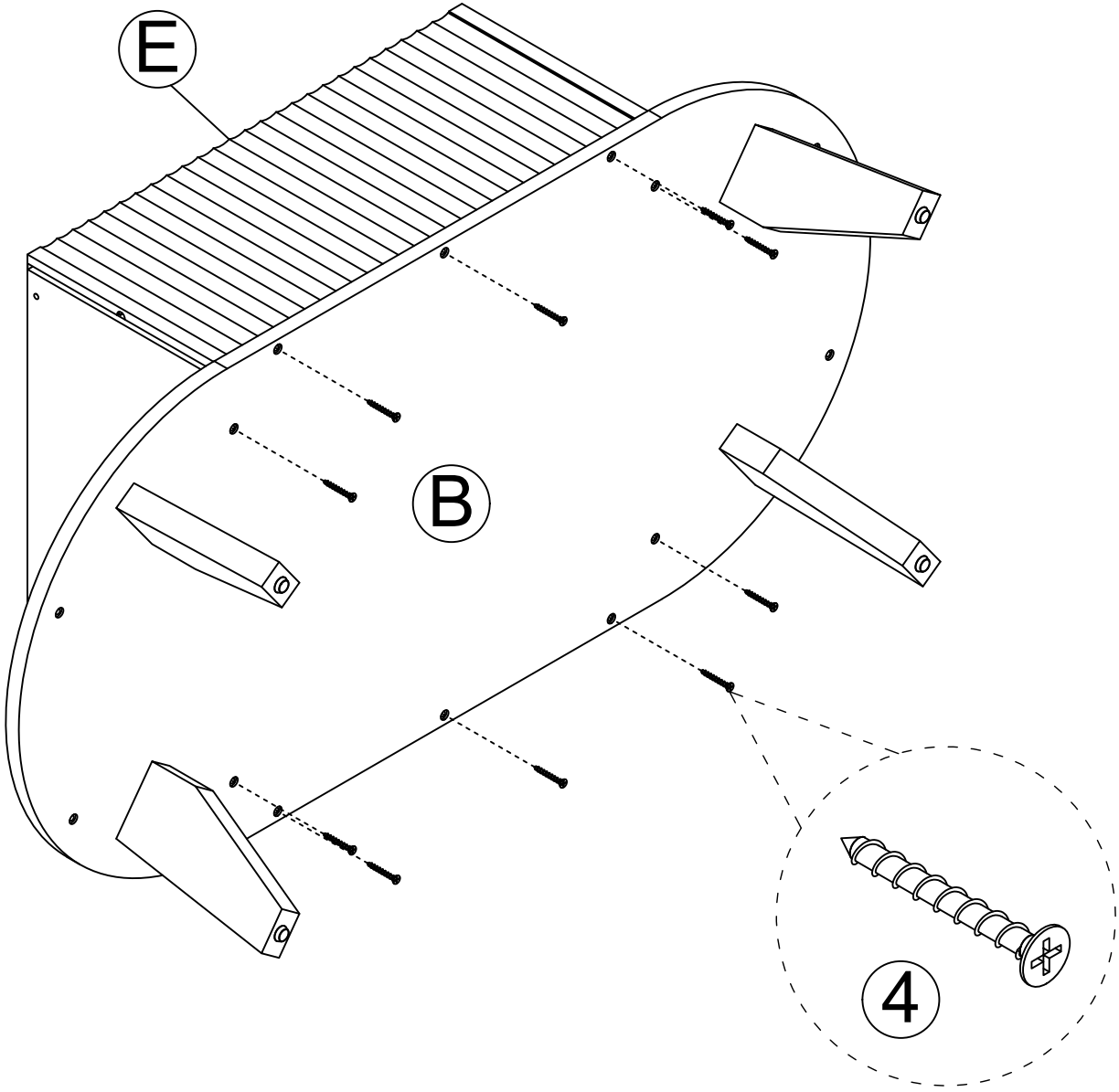

# STEP 5

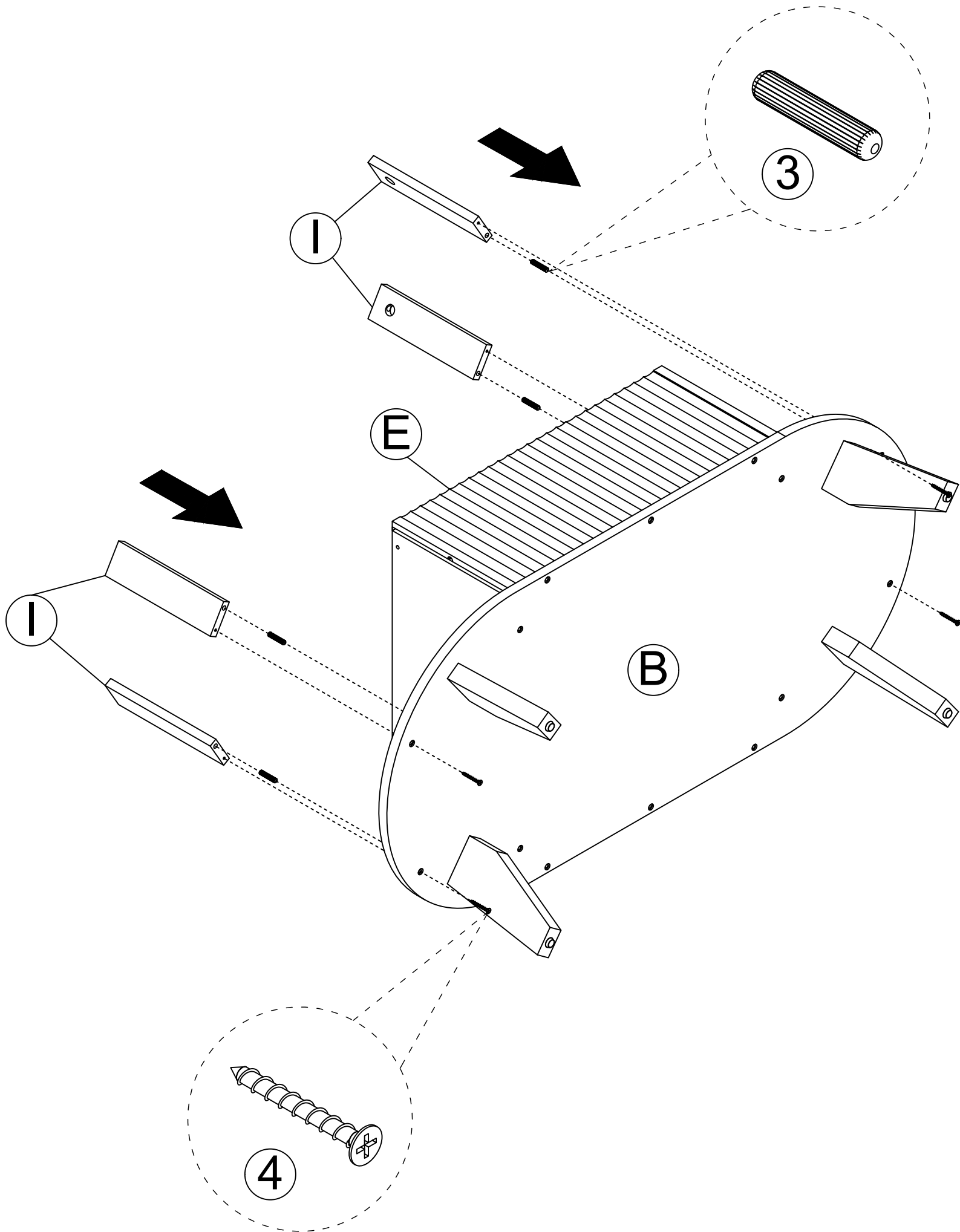
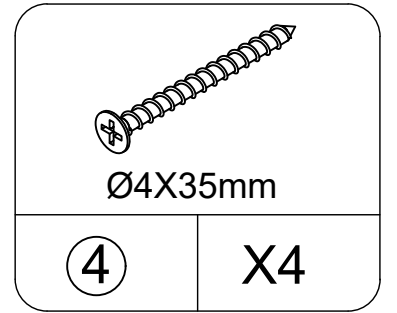
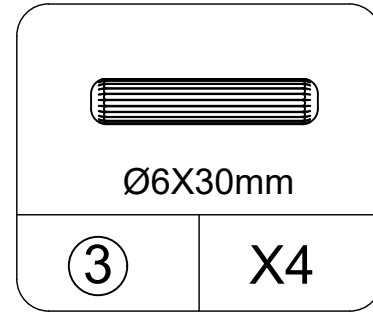
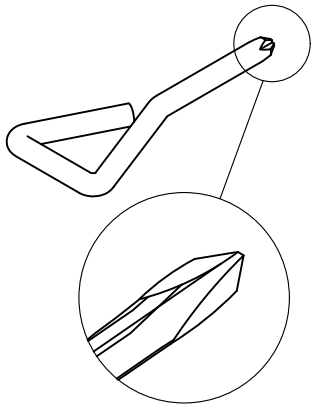

# STEP 6

---

## Step 1

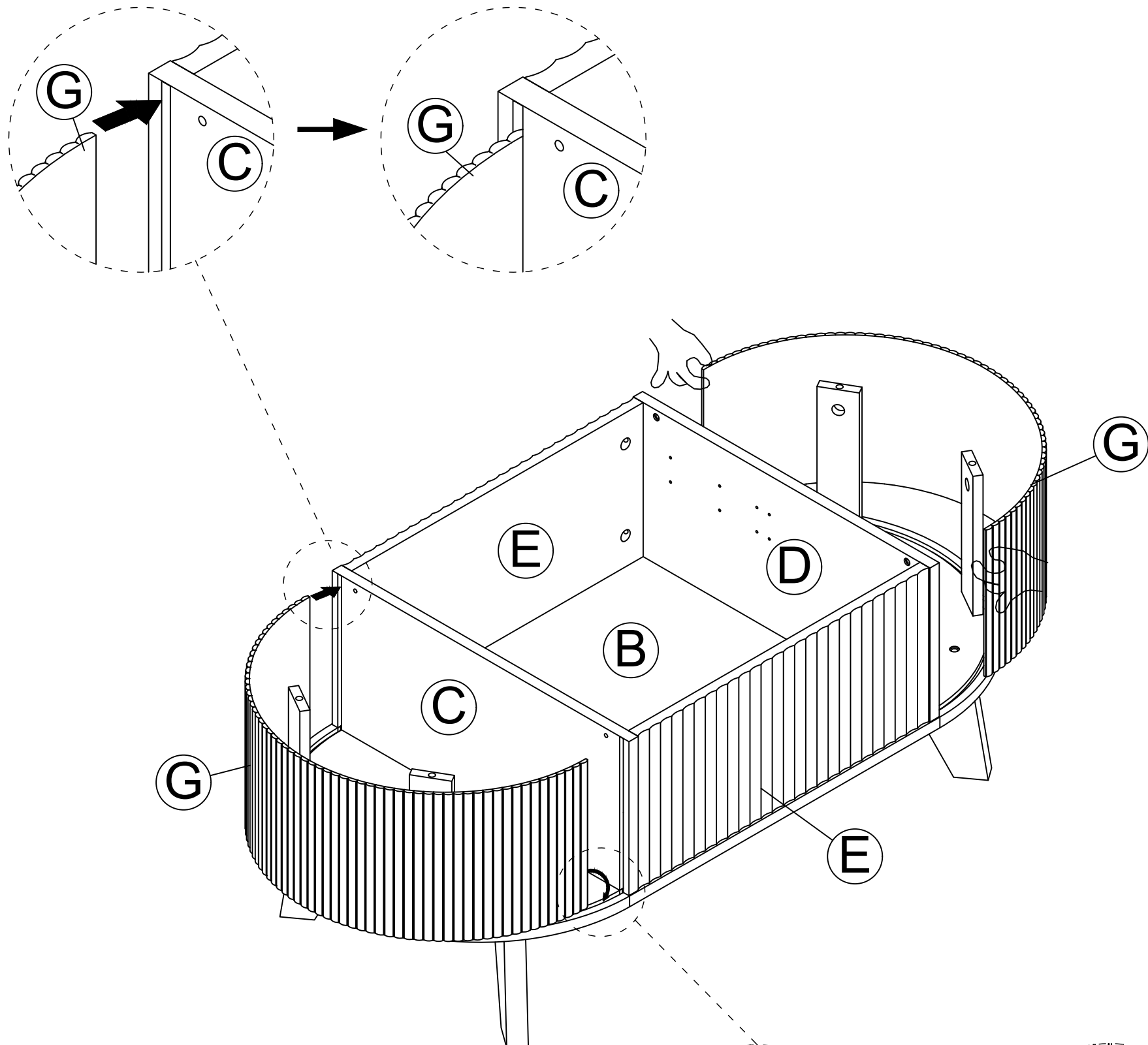

## Step 2

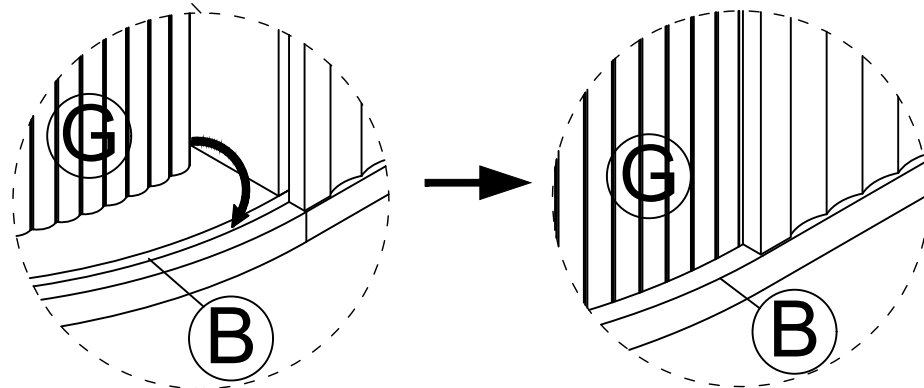

This step requires the assistance of one person. First, install the G board on the C board and make sure it is the same on both sides. Then, install the G board vertically on the B board.

After installation, hold the ends of the G board until the next step is completed.

Same operation on the other side

# STEP 7

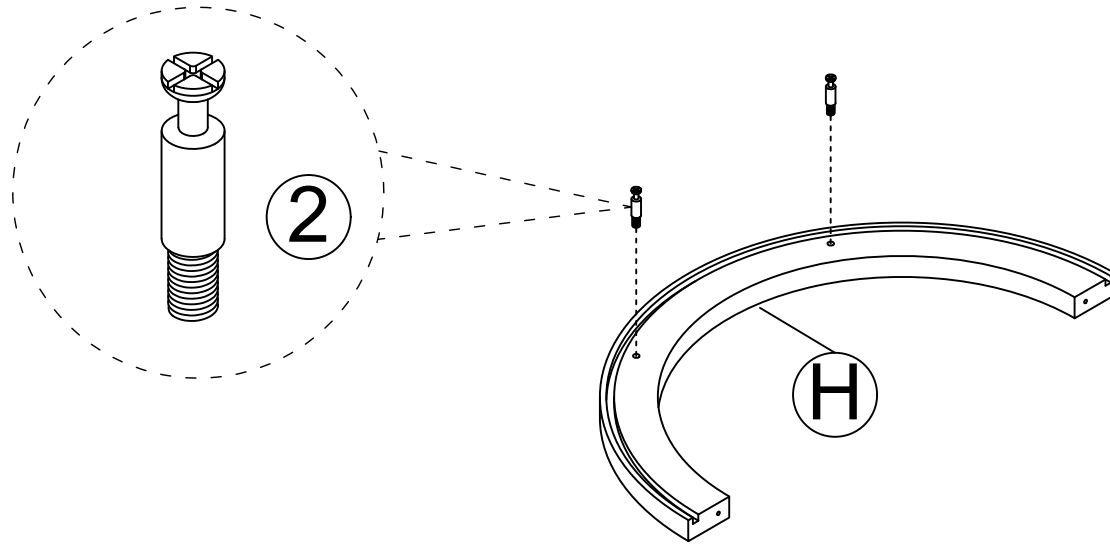
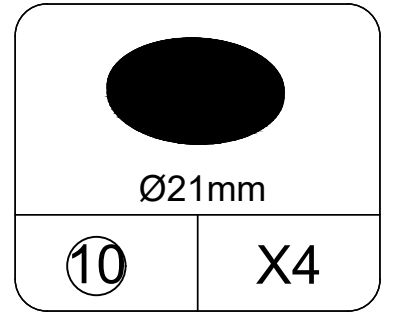
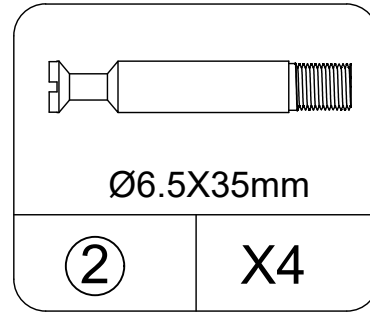
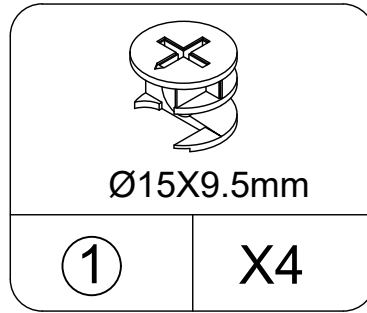
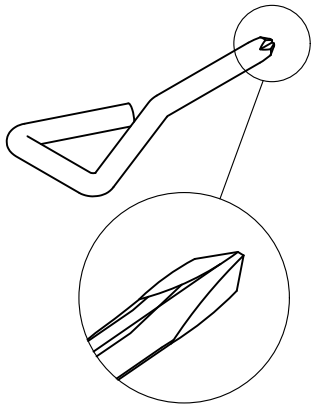

X2

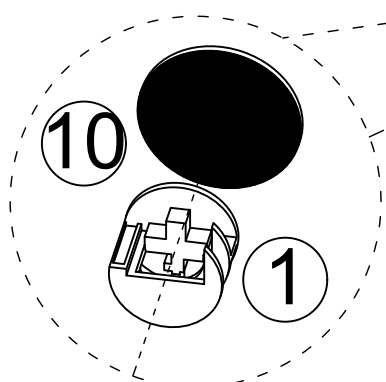
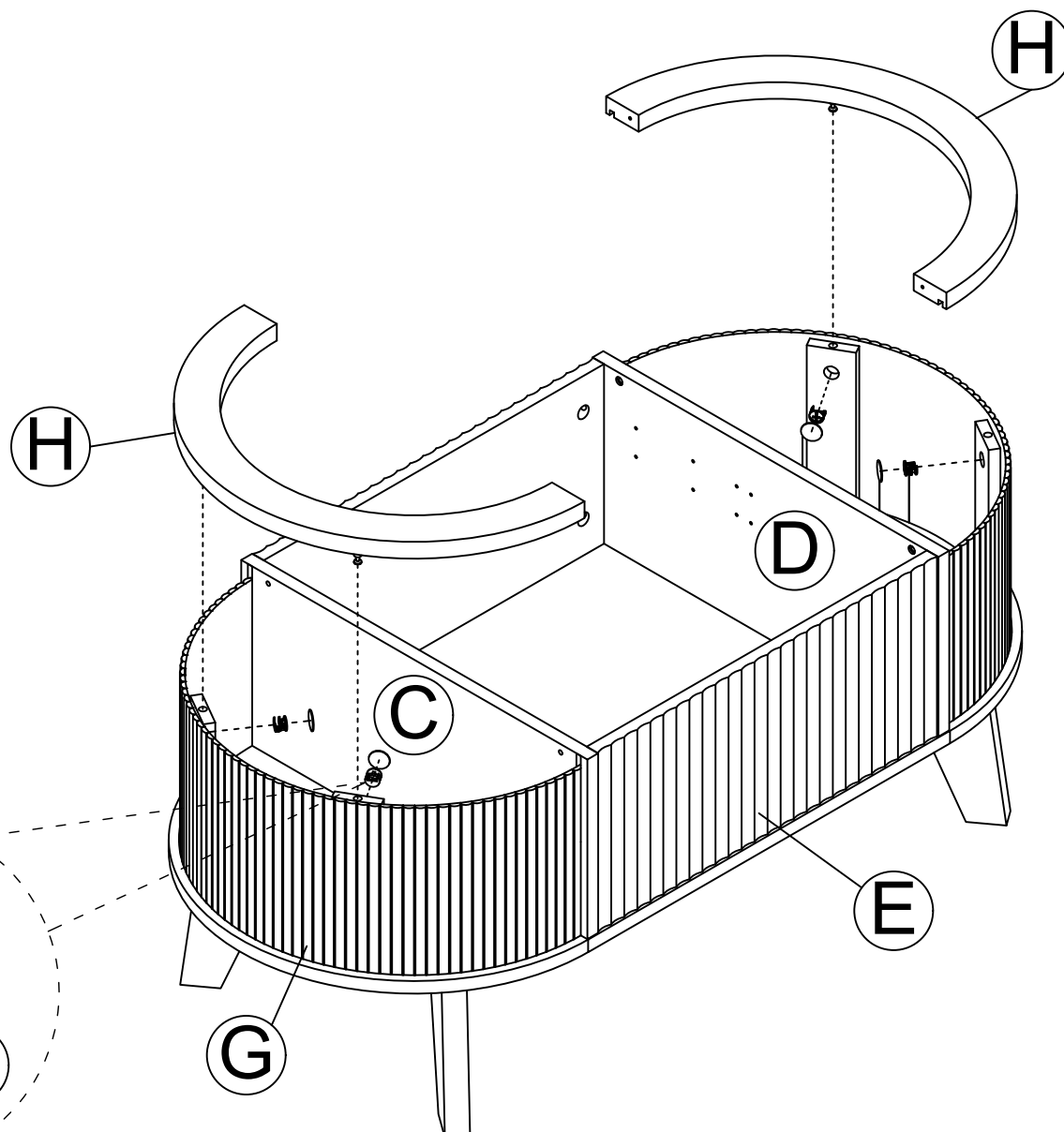
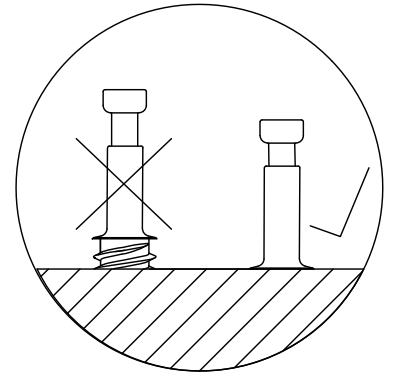

Insert the cam bolt into the hole first, then insert the cam lock and lock it.

# STEP 8

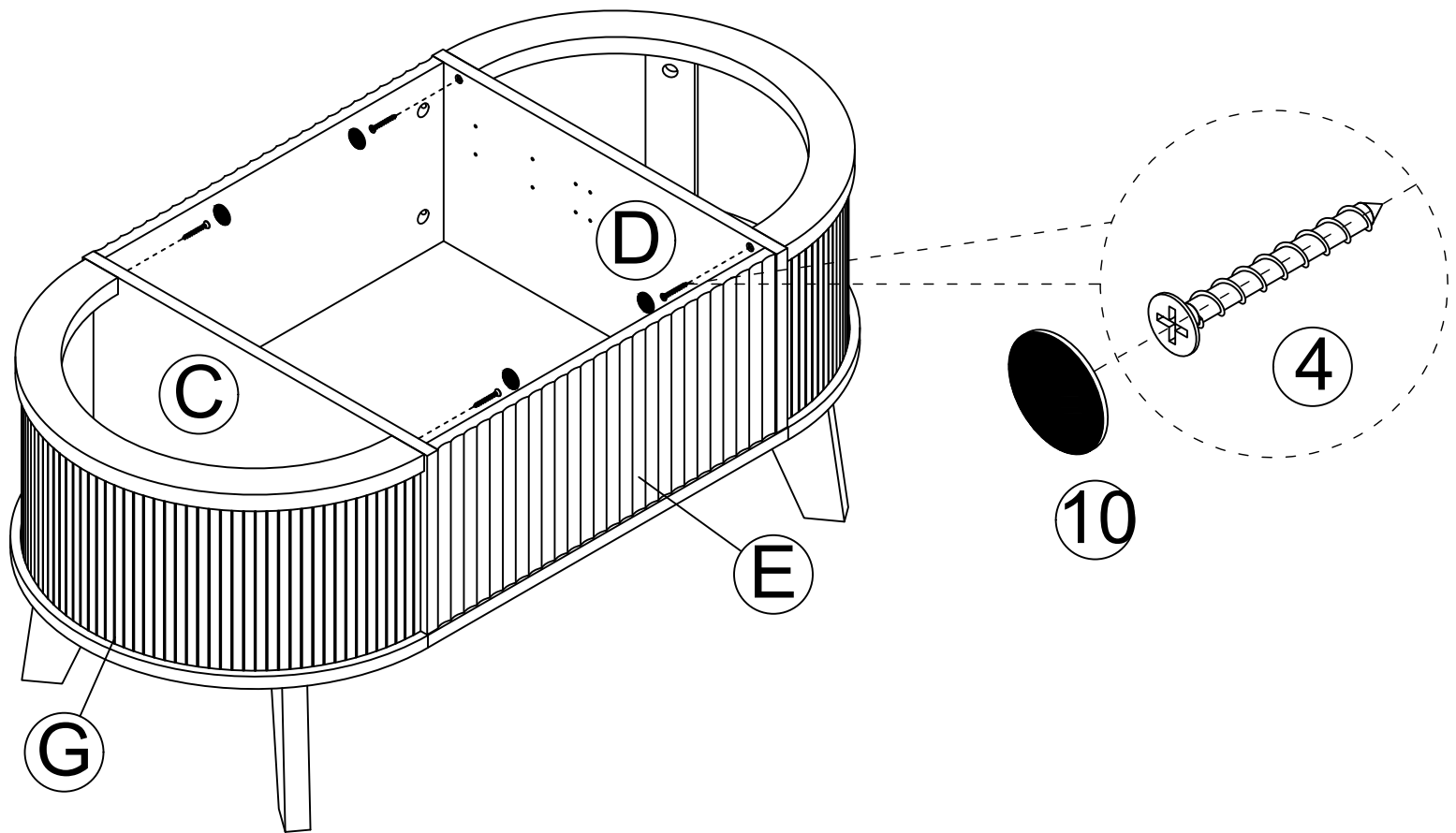
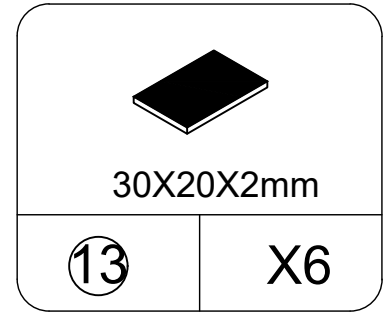
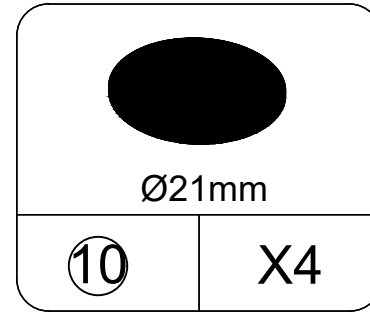
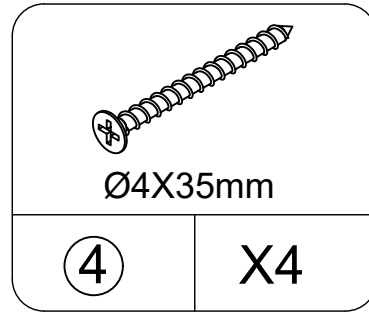
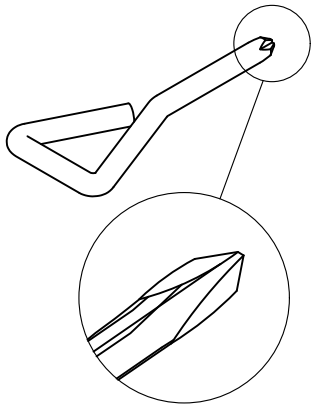

Peel the adhesive backing from the felt pad

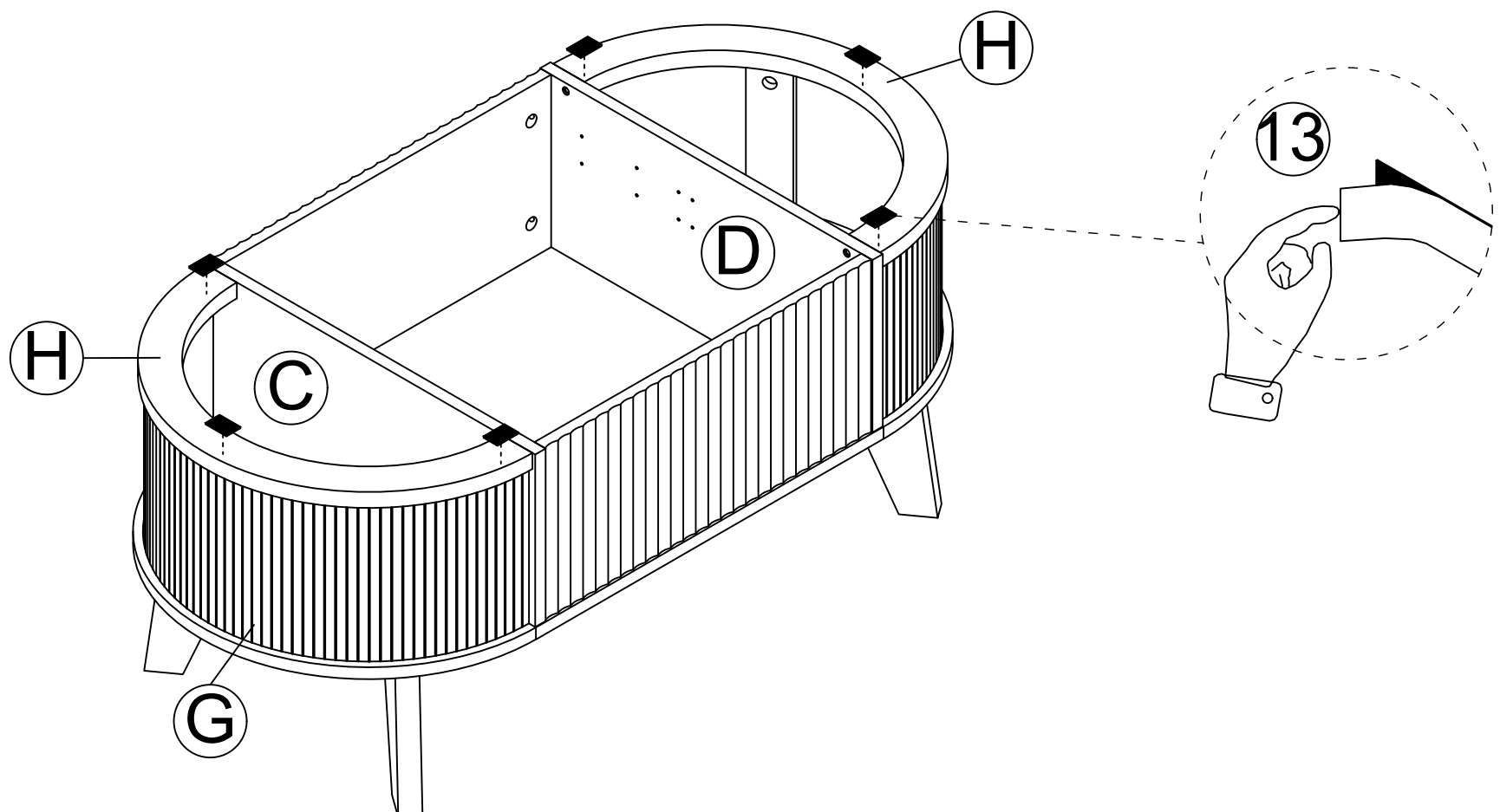

# STEP 9

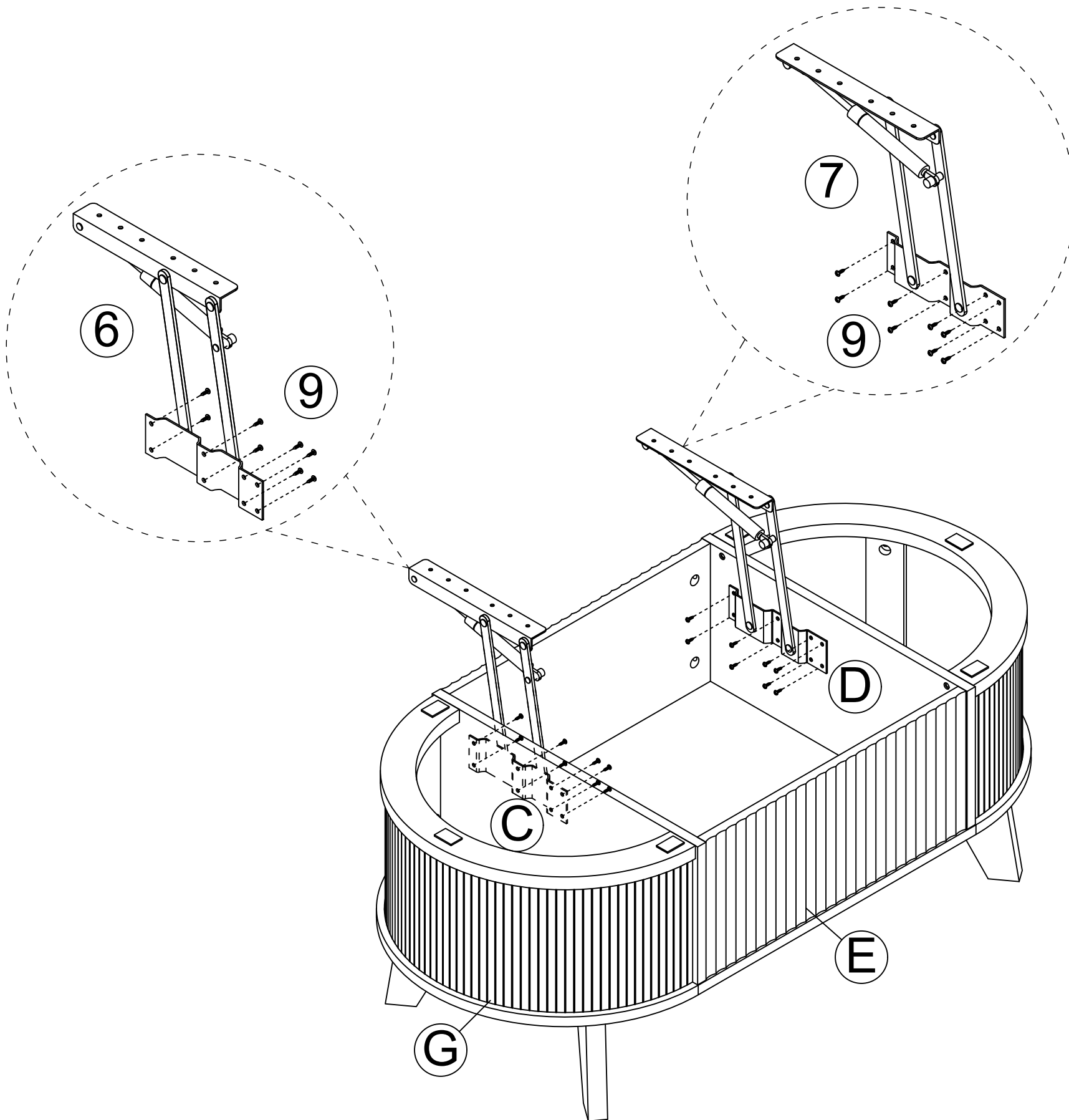
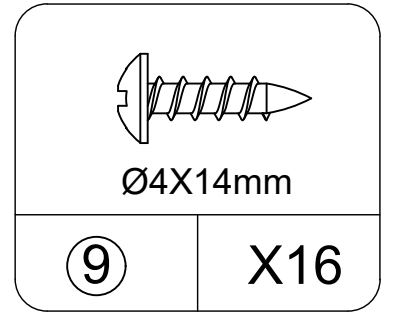
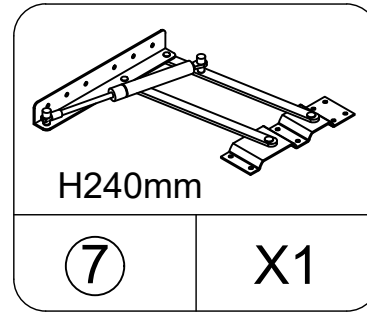
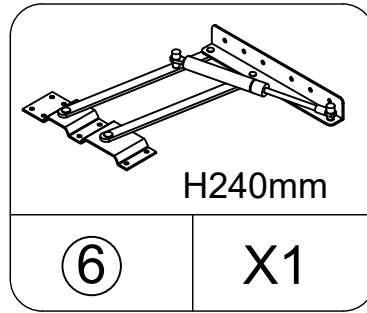
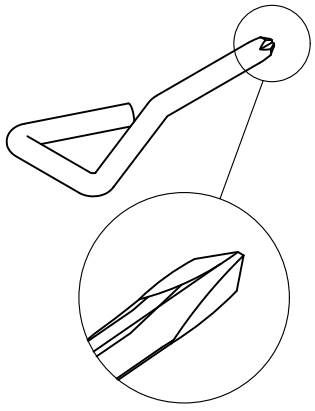

# STEP10

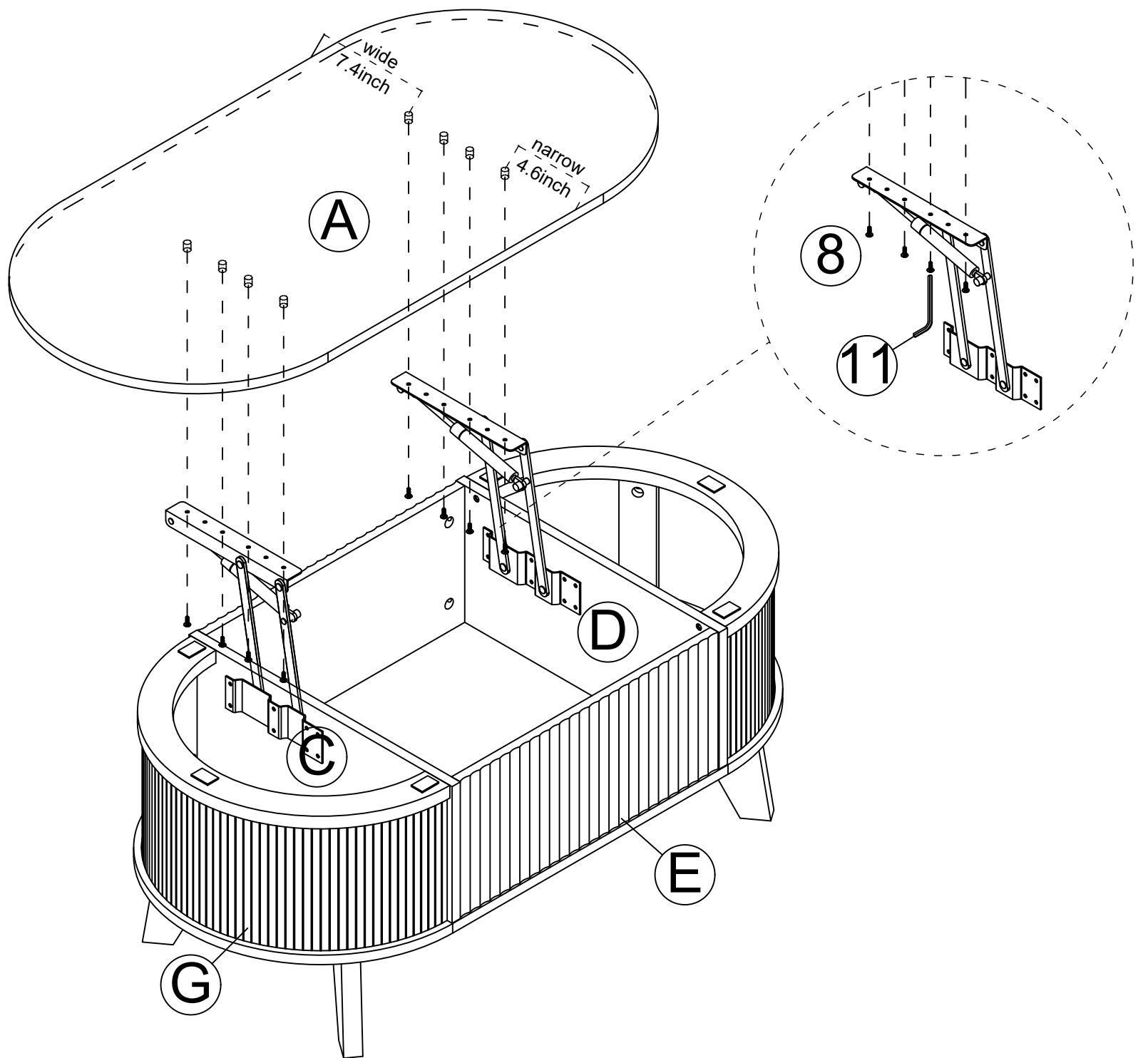
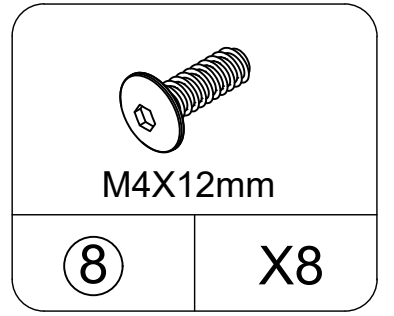
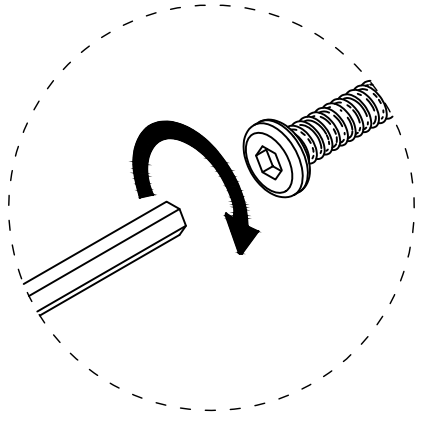

For this step, you need one helper.

# STEP11

---



The table surface lifting requires both hands to operate, one hand supports the left side of the table surface, and the other hand supports the right side of table surface for lifting, the descent is also the same operation.

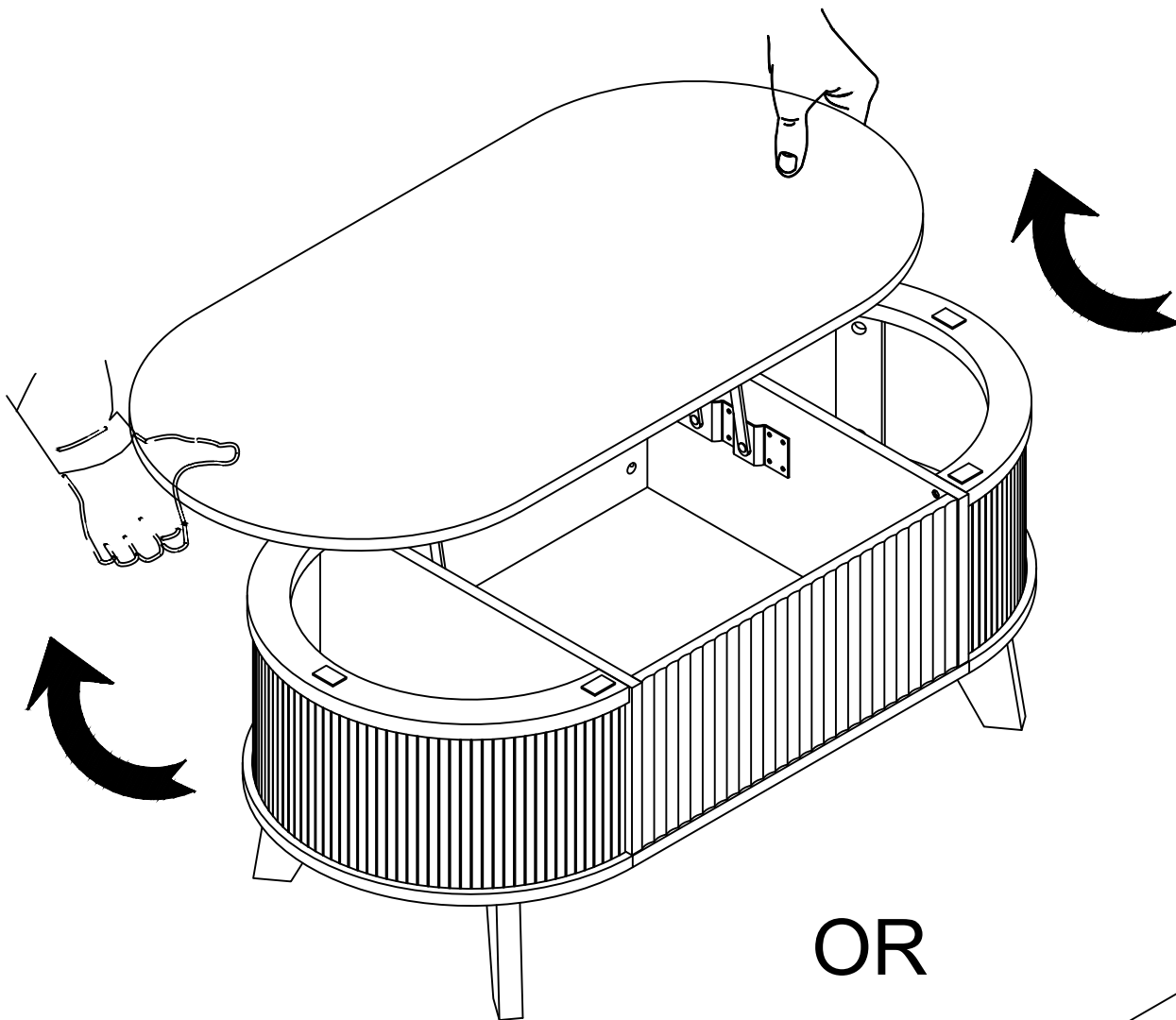

OR

