

ASSEMBLY INSTRUCTION

SKU:WF310757+WF310758

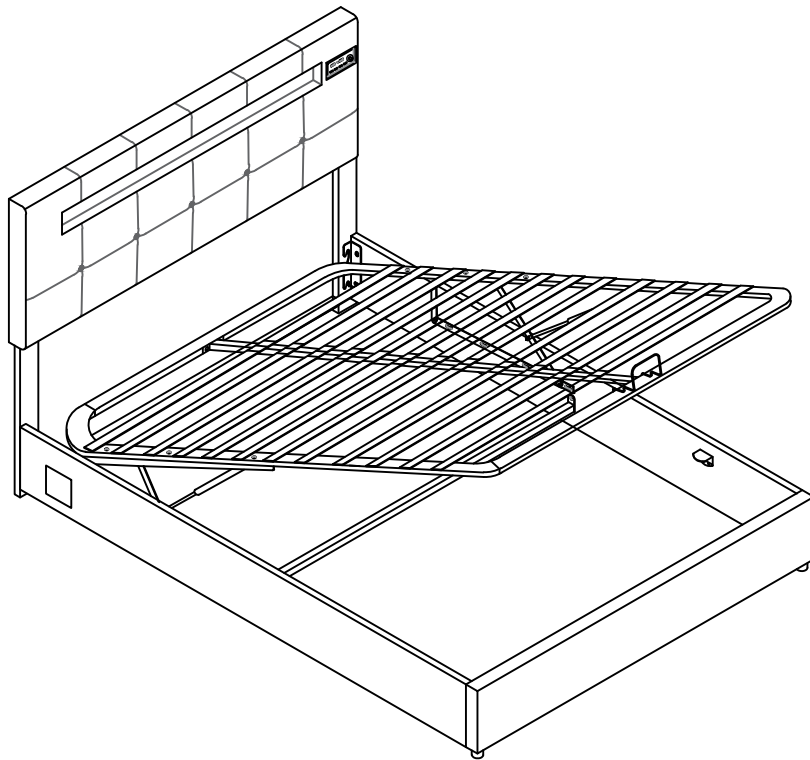

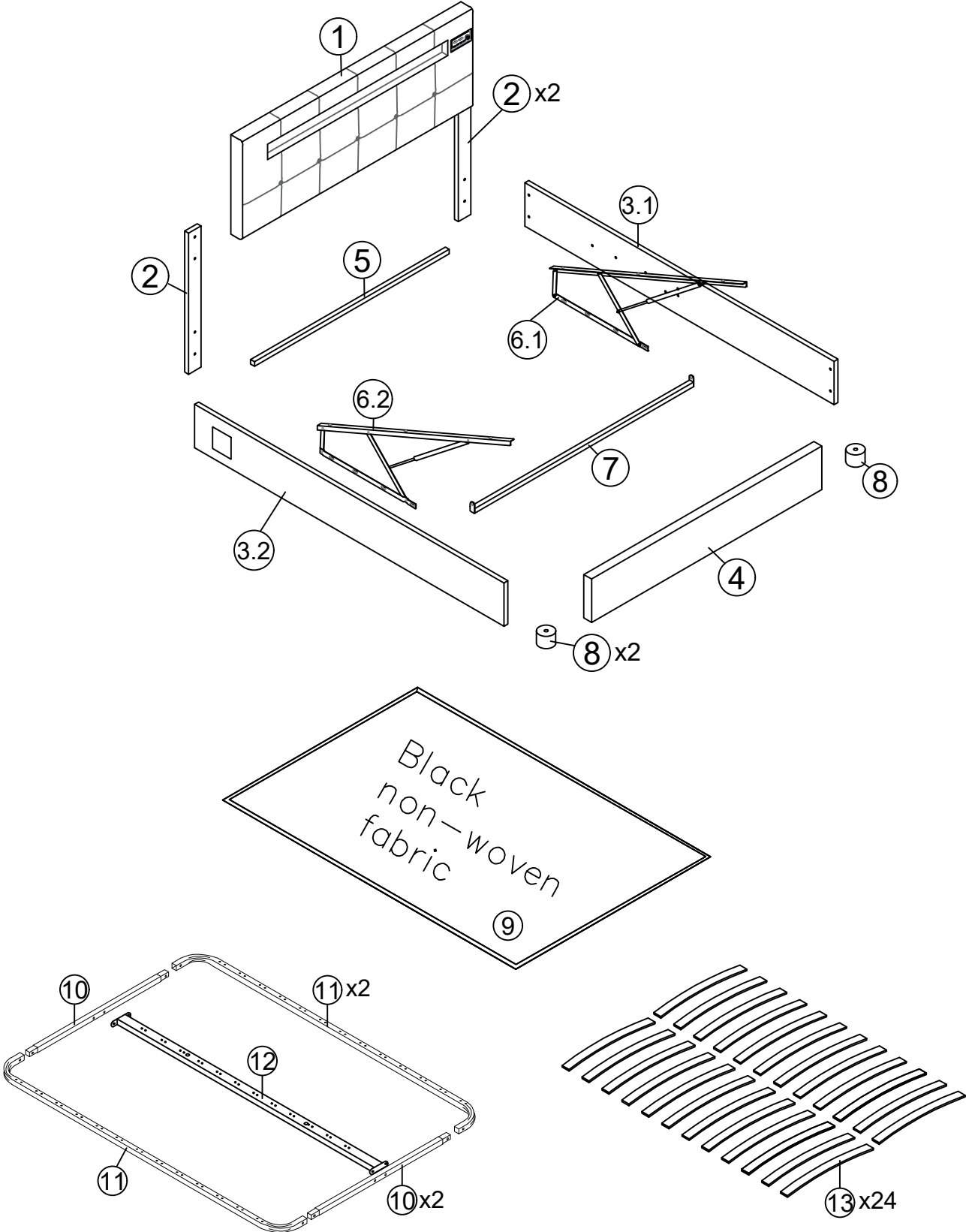





Detail View

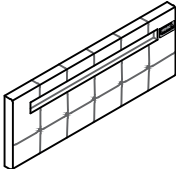

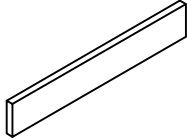
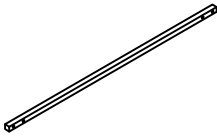
Part List

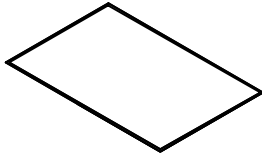
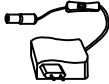
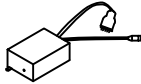

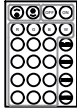



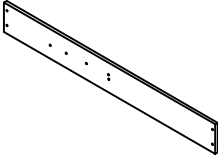
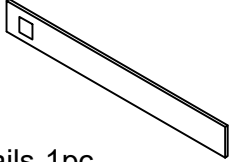
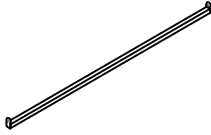
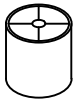
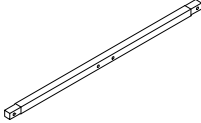
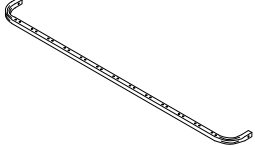
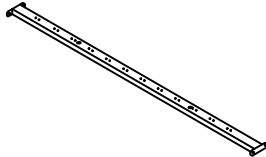
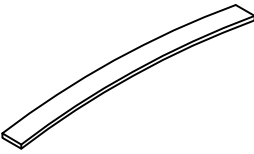





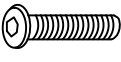

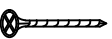
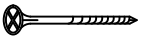
WF310757

<p>1</p>  <p>Head board-1pc</p>	<p>2</p>  <p>Head board leg-2pcs</p>	<p>4</p>  <p>Foot board -1pc</p>
<p>5</p>  <p>Head board cross bar-1pc</p>	<p>6.1</p>  <p>Gas lift -1pc</p>	<p>6.2</p>  <p>Gas lift -1pc</p>
<p>9</p>  <p>Black non-woven fabric-1pc</p>	<p>R</p>  <p>Led adapter-1pc</p>	<p>S</p>  <p>Color controller-1pc</p>
<p>T</p>  <p>Music adapter-1pc</p>	<p>U</p>  <p>AUX Line-1pc</p>	<p>V</p>  <p>Emote control(1pc)</p>

Hardware List+WF310758

<p>3.1</p>  <p>Side rails-1pc</p>	<p>3.1</p>  <p>Side rails-1pc</p>	<p>7</p>  <p>Cross bar-1pc</p>
<p>8</p>  <p>Legs-2pcs</p>	<p>10</p>  <p>Metal frame cross bar-2pcs</p>	<p>11</p>  <p>Metal frame side bar-2pcs</p>
<p>12</p>  <p>Metal frame middle bar-1pc</p>	<p>13</p>  <p>Slat-24pcs</p>	

Hardware List

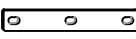

A  20*70mm	B  Ø8*45mm	C  Ø22
Allen Key(1pc)	Bolts(20pcs)	Washer(4pcs)
D  Ø8*18mm	E  Ø15mm	F  Ø4*25mm
Bolts(22pcs)	Nuts(14pcs)	Nails(12pcs)
G  Ø4*50mm	H  Ø12mm	I  Ø6*25mm
Nails(2pcs)	Nuts(2pcs)	Bolts(10pcs)
J  70*23mm	K  150*40mm	L  43*33mm
Spanner(1pc)	Hinge(4pc)	Poly support(4pcs)
M  25*25*215mm	N  55*52*11mm	O  55*27*11mm
Middle legs(2pcs)	Middle slats cap(12pcs)	End slats cap(24pcs)
P  140*118mm	Q  156*24*2mm	
Stopper(1pcs)	Three hole iron(2pcs)	

Attention: Do not tighten the screws before completing the entire installation. If you have any difficulty with the installation process, please feel free to contact us.

Step 1x2

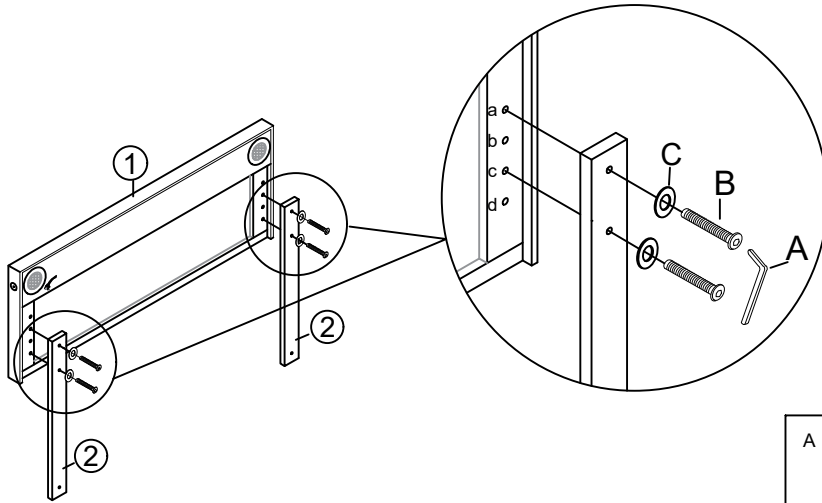
Fix the Headboard legs ② to the headboard ① with Bolts B and Washers C by using Allen key A, you can chose the holes a and c or b and d .





A Allen Key x1 	B Bolts x 4  M8X45mm	C Washer x 4 
---	---	---

Step 2x2

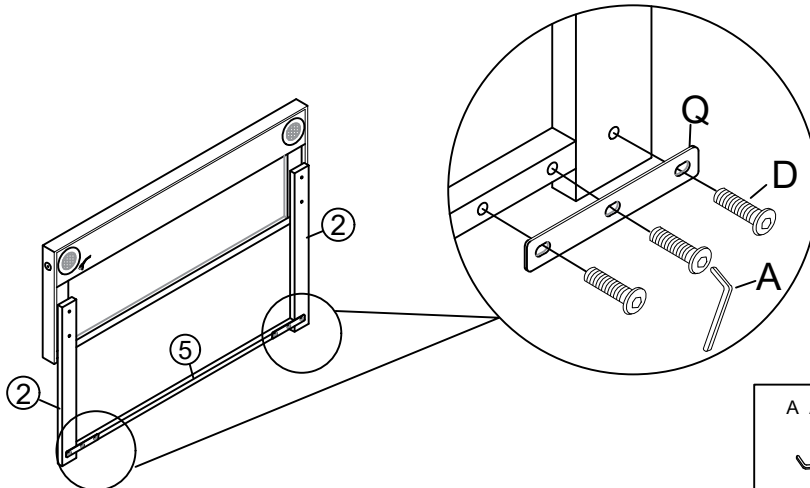
Fix the Headboard cross bar ⑤ to the Headboard legs ② with Bolt D and Three hole iron Q by using Allen key A.





A Allen Key 	D Bolts x 6  M8X18mm	Q Three hole iron x2 
--	---	---

Step 3

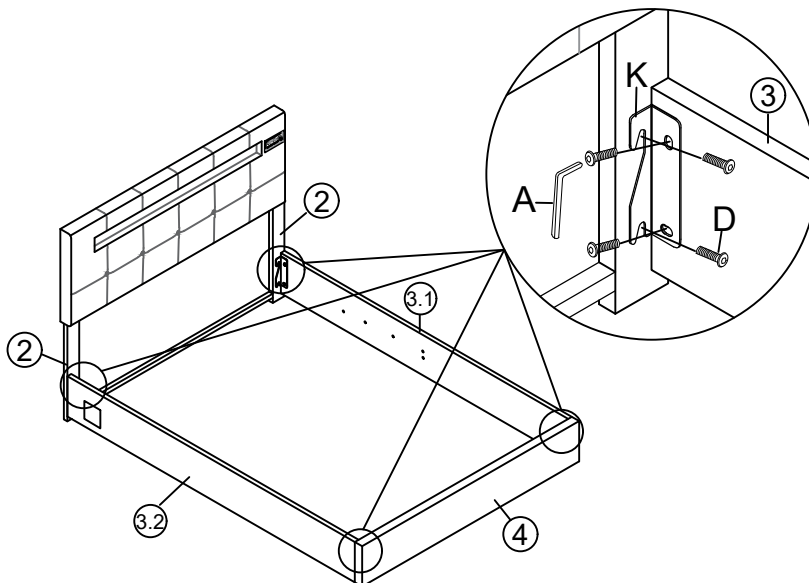
Fix the side rails ③ to the side head board legs ② and footboard ④ with Bolts D and hinges K by using Allen key A .





A Allen Key 	D Bolts x 16  M8X18mm	K Hinge x4 
--	--	---

Step 4

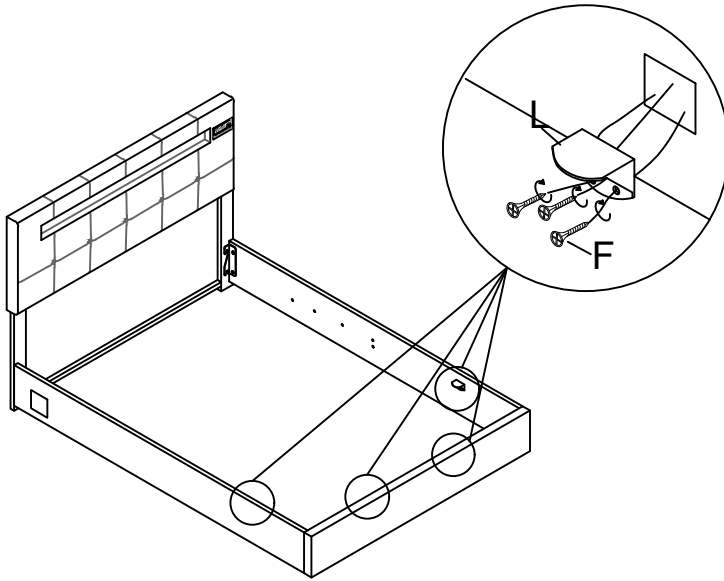
Fix the plastic support L to the side rails ③ and footboard ④ with nails F by using electric drill or screw driver .



F Nails x 12  M4X25mm	L Plastic support x 4 
--	--

Step 5

Stick the black non-woven fabric ⑨ to the bottom of bed .

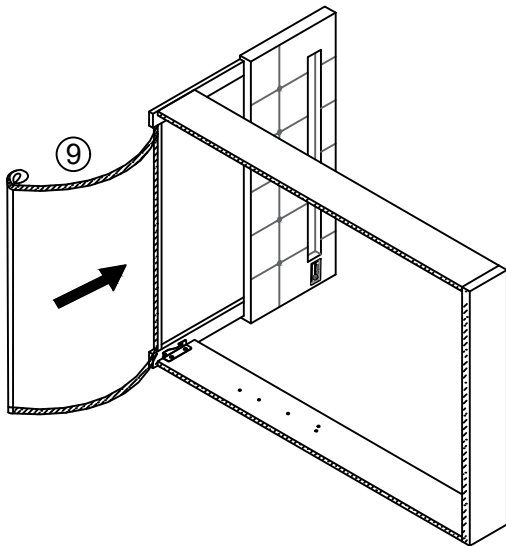

Step 6

Fix the legs ⑧ to the footboard ④ with nails G by using electric drill or screw driver

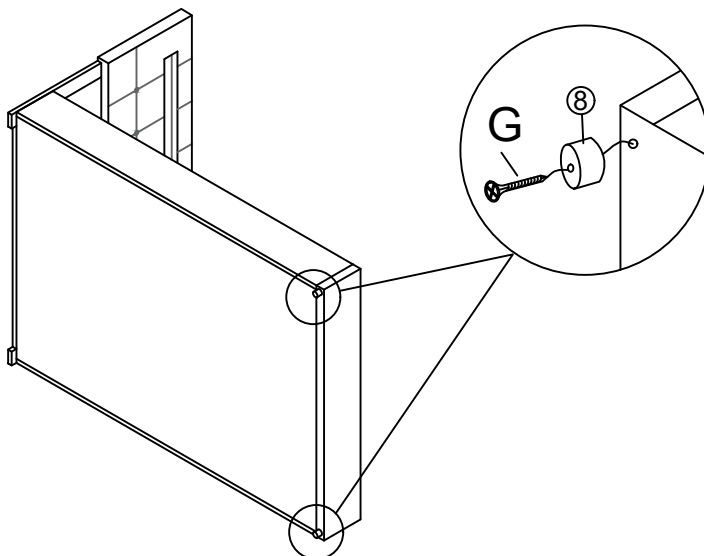

G Nails x2  M4X50mm
--

Step 7

Fix the cross bar ⑦ to the side rails ③ with Bolts I by using electric drill or screw driver.

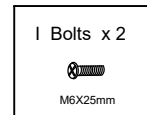
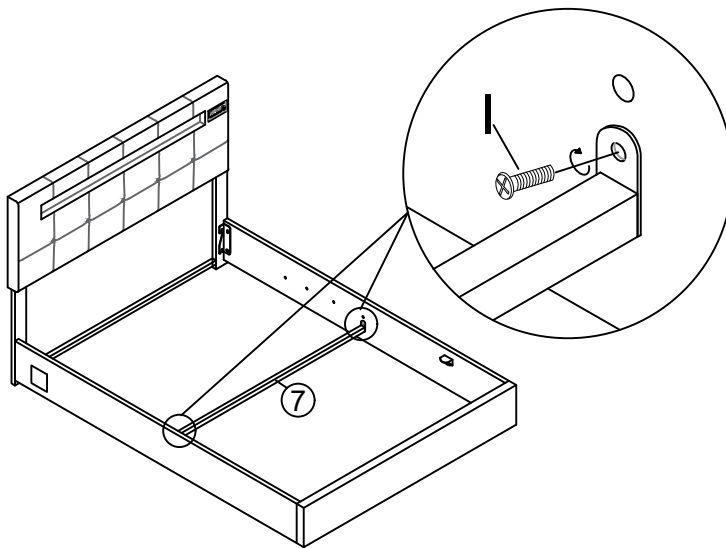

Step 8

Fix the gas lifts ⑥ to the side rails ③ with bolts I by using electric drill. Fix the gas bar to the gas lifts ⑥ with nuts H. Nuts H is the gas lift box.

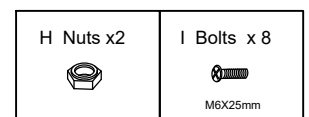
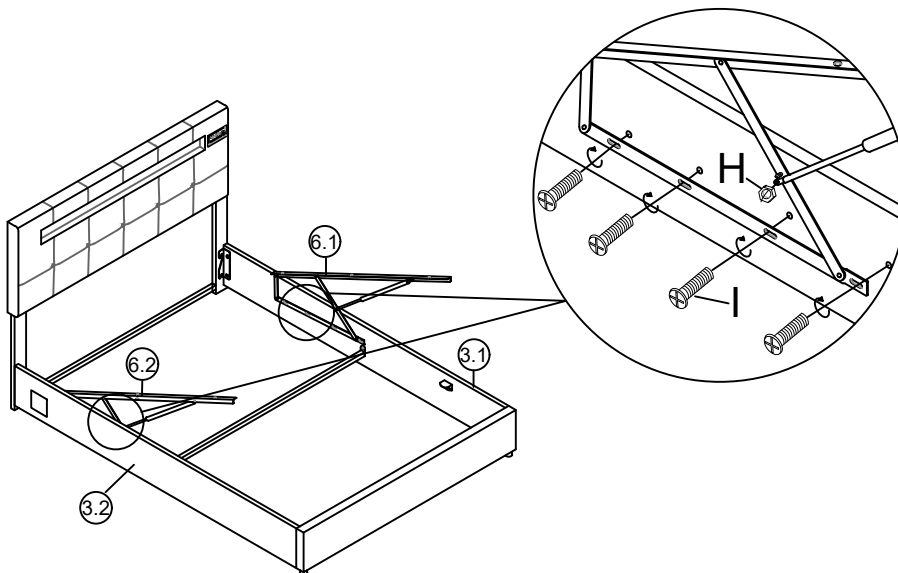

NOTICE:

The hole on the gas list is oval, please make sure that the installation positions on the left and right are roughly the same. If you accidentally install the gas lift one side to the front and the other to the back, which affects your use, you can write it down and reinstall it.

Step 9

Assemble the slats frame with bolts B and nuts E by using Spanner J

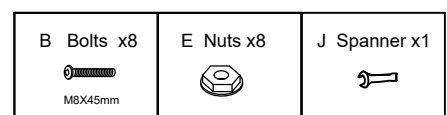
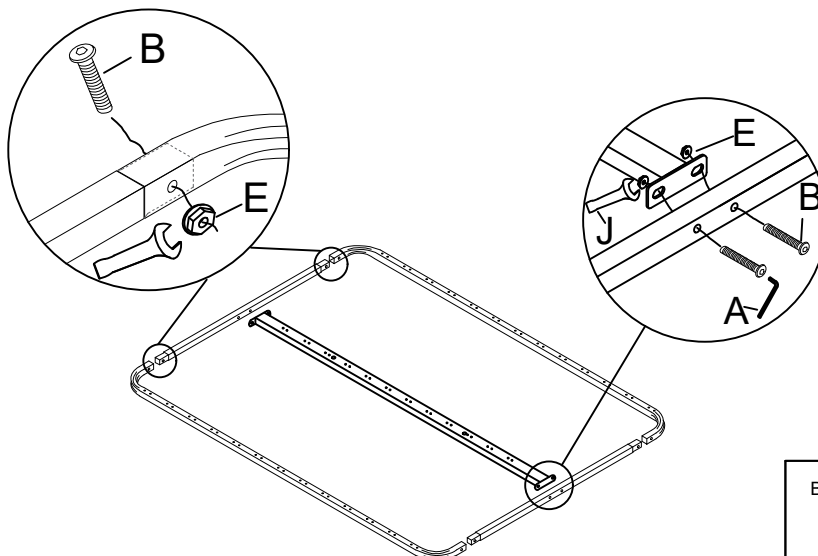

Step 10 x2

Fix middle legs M to the middle bar with bolts B by using Allen key A

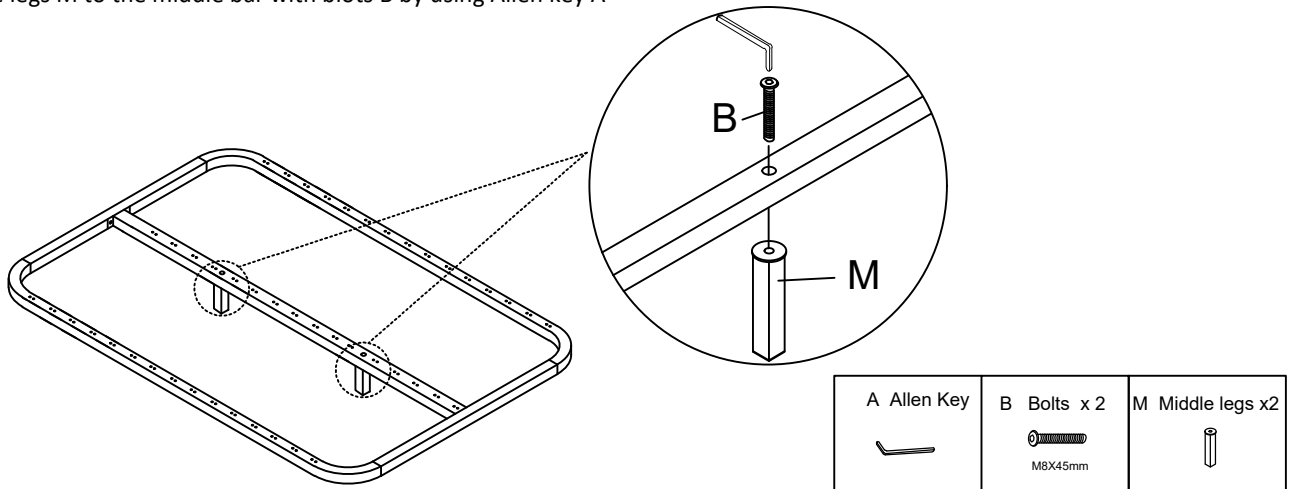

Step 11

Assemble the slats into the assembled slats frame with middle slats cap N and end slats cap O

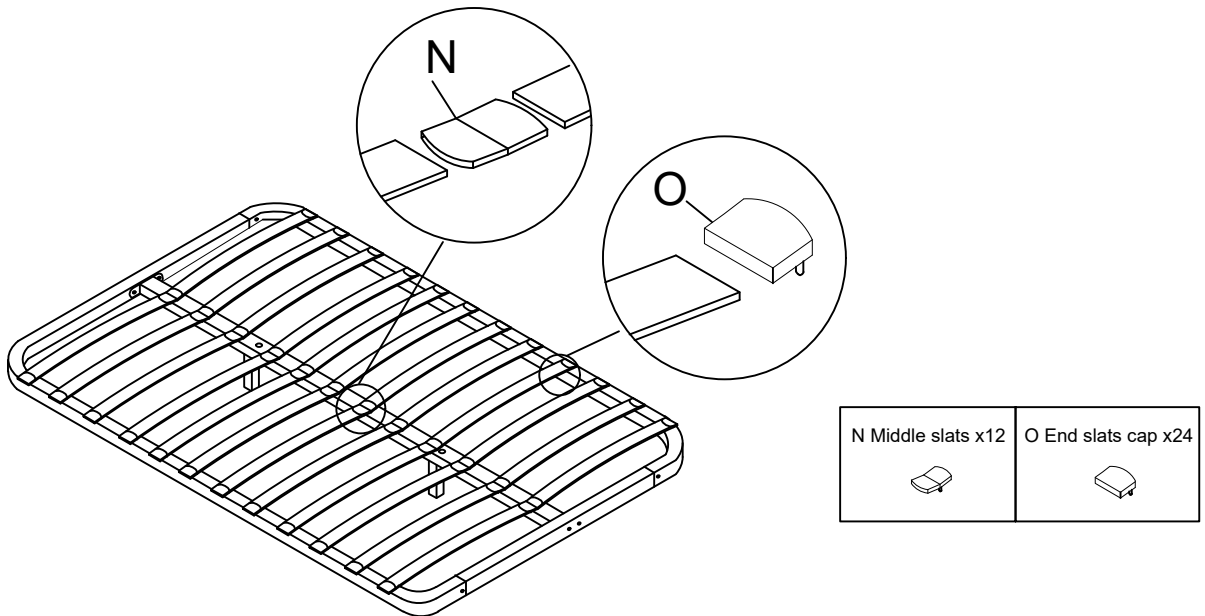

Step 12

Assemble the slats frame ⑪ to the gas lifts ⑥ with bolts B and nuts E, put the stopper P in the end of the slat frame, then assemble is finished, now please tighten all hardware

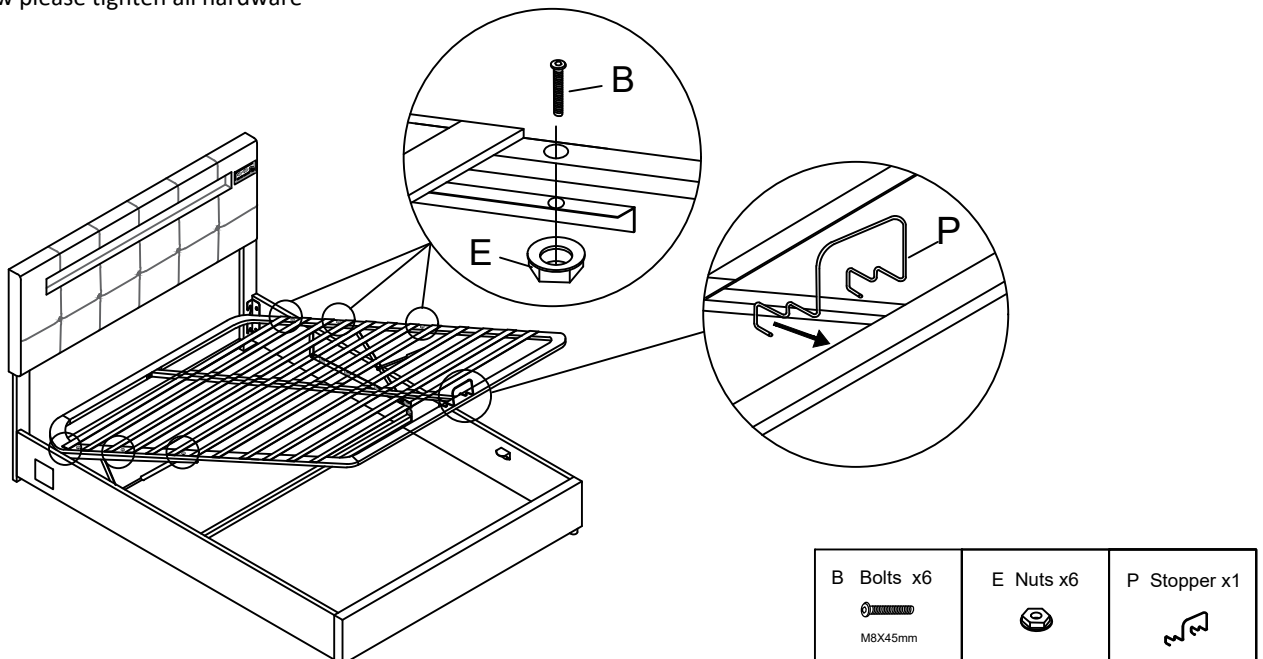



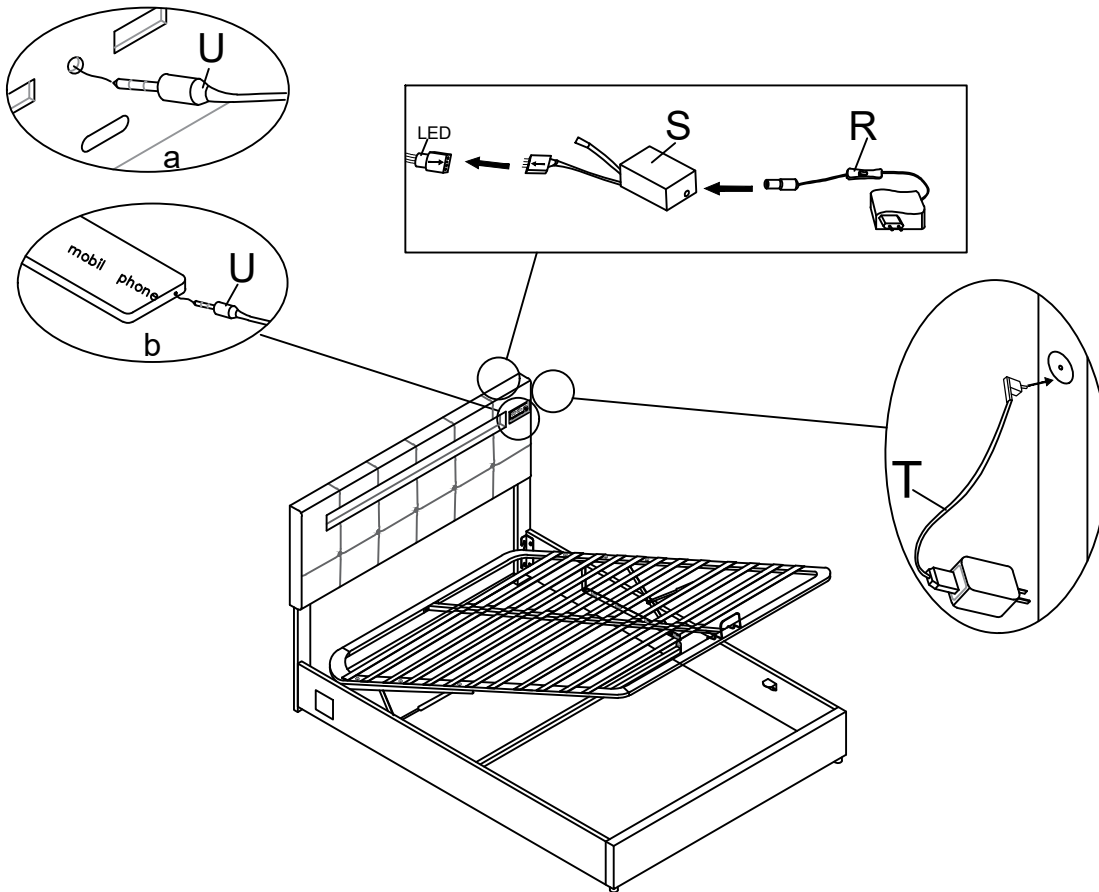

Step 13

Put the color controller S to the light line ,please notice that → ←.

Fix the Led adapter R to the Color controller S.Put one end of T into the headboard.Finally connect the power,and enjoy the bed.



R Led adapter x1	S Color controller x1	T Music adapter x1	U AUX Line x1
			

Notice: The adapters of LED light and Bluetooth player are different. The color of LED light adapter box is white. The box named "FITTINGS" is for Bluetooth player.

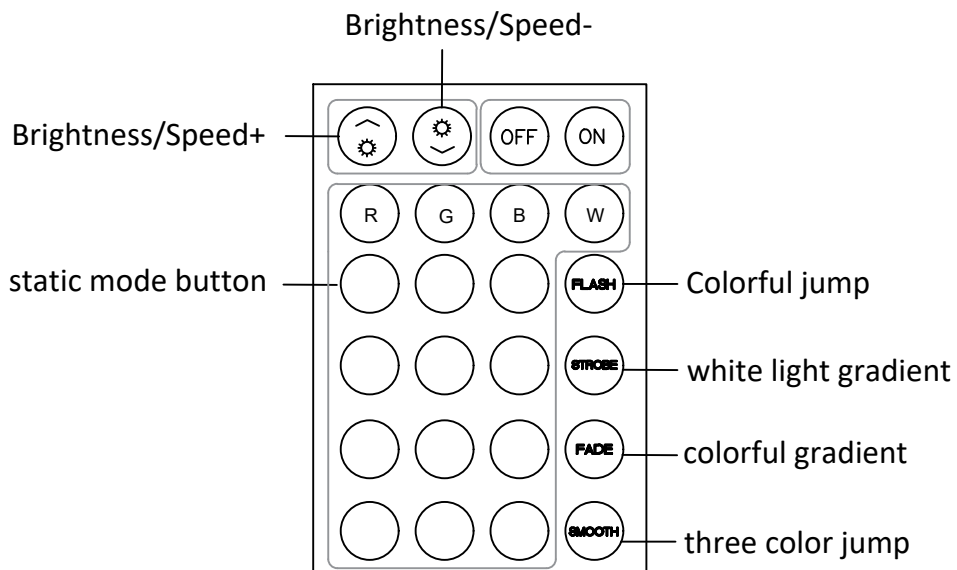

NOTICE:

When you use the remote control board to control the color of the light, Please remove the clear plastic card first, then please be sure to point the remote control at the color controller S.