

Assembly Instructions

Flat Mid Back Office Chair

PLEASE NOTE: Check that you have received all components and hardware before assembling. If you are missing any parts, contact your retailer.



IMPORTANT NOTE:
Screws and washers (Parts H) are preassembled into the underside of the seat (Part B). Remove screws and washers from seat and then use to attach Part C to Part B, as shown in step 1.

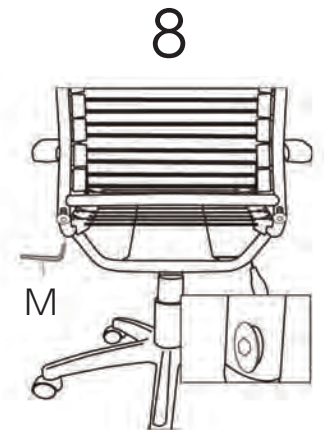
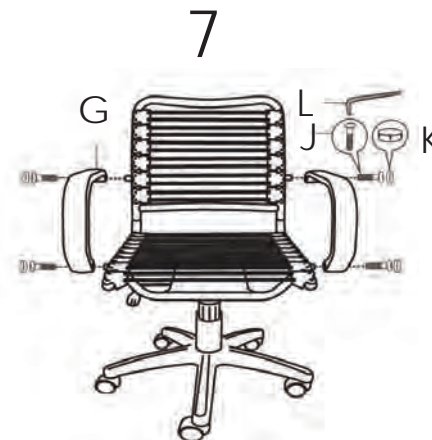
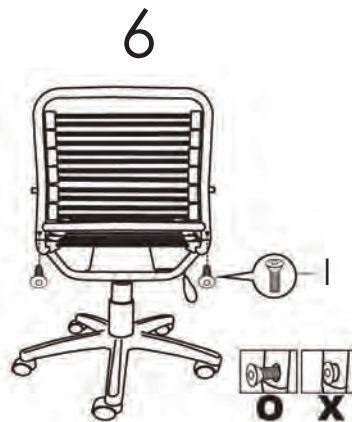
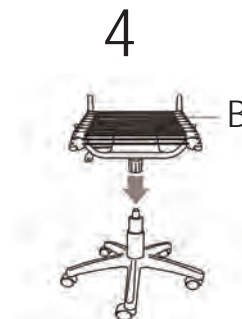
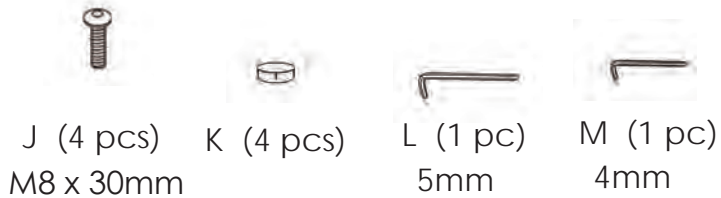
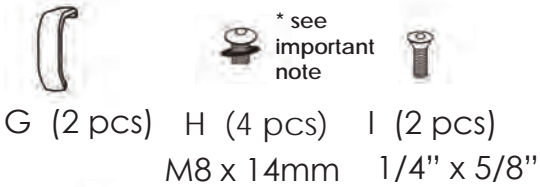
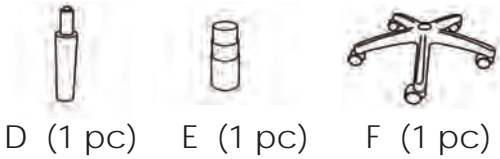
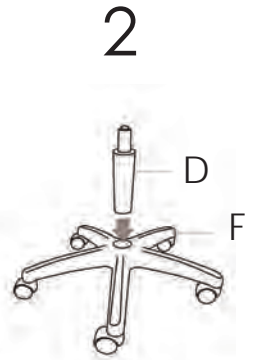
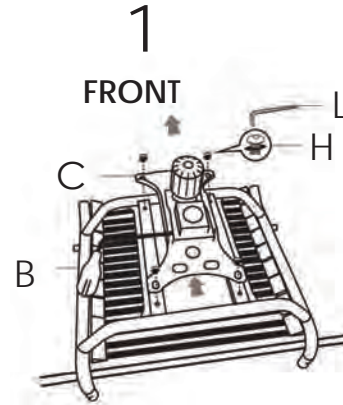

During assembly, hand tighten screws only. When the screws are in place, tighten completely.

Function Description

PLEASE NOTE: Check that you have received all components and hardware before assembling. If you are missing any parts, contact your retailer.

1. To adjust chair height



2. Chair tilt and lock

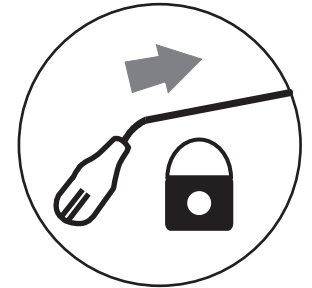
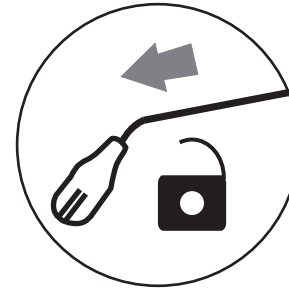

3. To loosen or tighten chair tilt

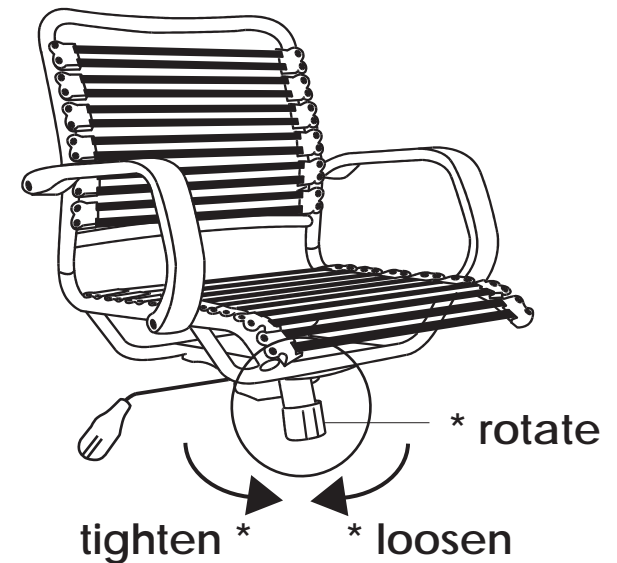

During assembly, hand tighten screws only. When the screws are in place, tighten completely.