

SIDEBOARD BUFFET & WINE RACK

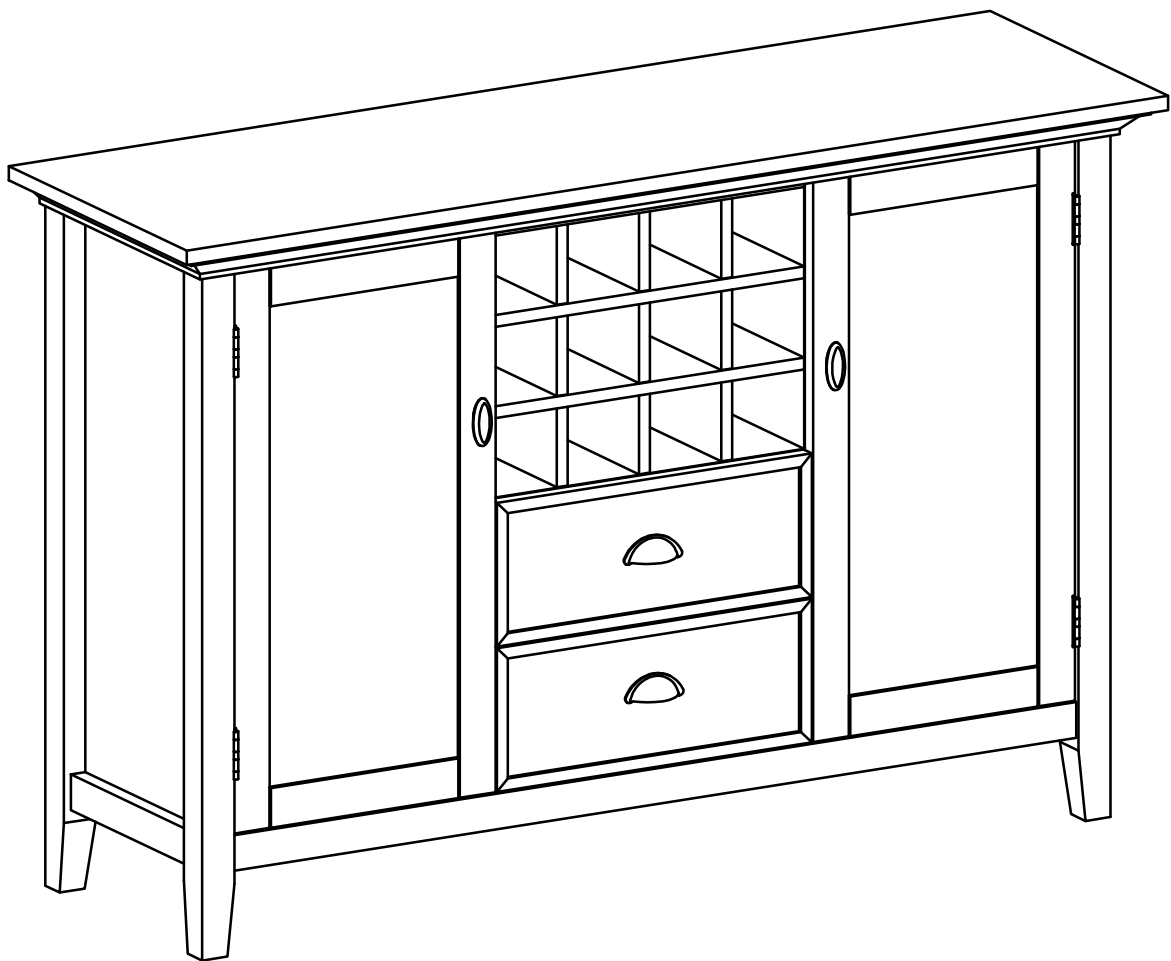



FOR REPLACEMENT PARTS OR HELP WITH
ASSEMBLY PLEASE CONTACT US

PLEASE ENSURE TO HAVE THE MODEL #
FROM THE PACKAGING OR INSTRUCTION BOOKLET

TO RETURN THE PRODUCT:
PLEASE CONTACT THE RETAILER
WHERE THE ITEM WAS PURCHASED FROM

IMPORTANT : Please read this manual carefully before beginning assembly of this product. Keep this manual for future reference.

SAFETY INFORMATION

CAUTION: Injuries and damage can occur from furniture tip over if product is not properly anchored to the wall. Use the Furniture Anti-Tipping Restraint provided with the product. Consult our assembly instructions for help. If the Furniture Anti-Tipping Restraint kit is not in the box, please contact our customer service department in order to obtain another kit before using the furniture.

Identify all the parts and hardware. Do not discard of the packaging until you have checked that you have all of the parts and hardware required. Hardware package may have spare parts.

WARNING: This item contains small parts which can be swallowed by children and pets. Keep children and pets away during assembly. To avoid danger of suffocation, always keep plastic bags away from children and pets. We recommend that you assemble this unit on a carpeted floor to avoid scratches. If using power tools, set the tool to low torque to avoid damage.

May require 2 people for ease of assembly.

CARE and MAINTENANCE

To clean, use a soft or slightly damp cloth, then wipe with a clean, dry cloth. Dust with soft dry cloth.

Do not use ammonia-based cleaning products, as they will damage the finish. Do not leave liquids or damp cloths on this furniture.

To avoid dulling of the finish, do not place furniture in direct sunlight.

Please inspect and tighten all screws or bolts on a regular basis to ensure proper performance and safety of your item.

PRE-ASSEMBLY INFORMATION

PART DESCRIPTION

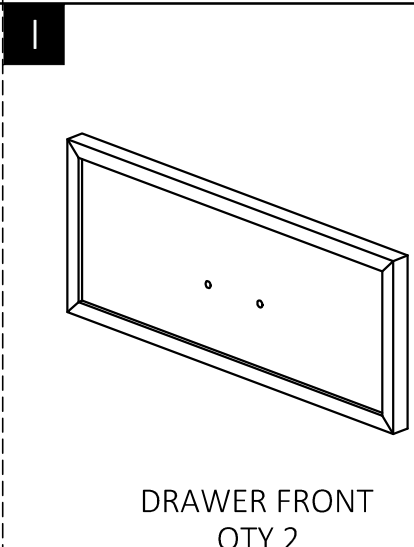
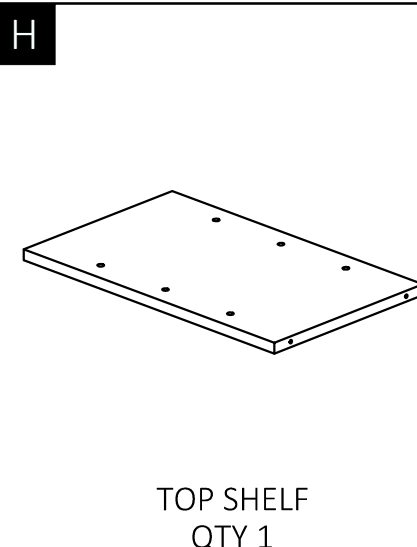
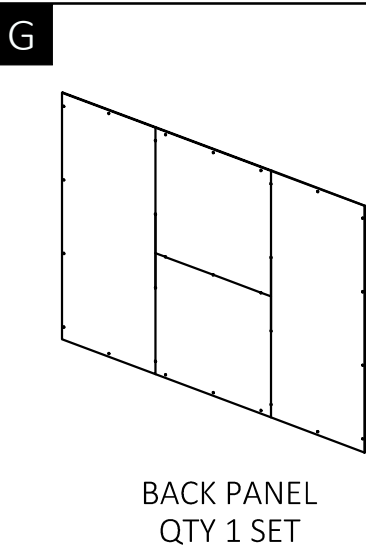
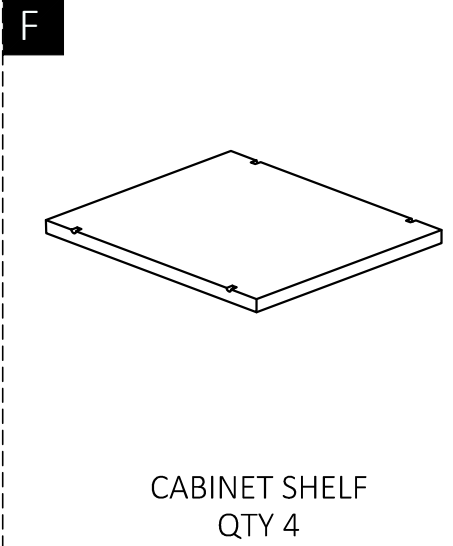
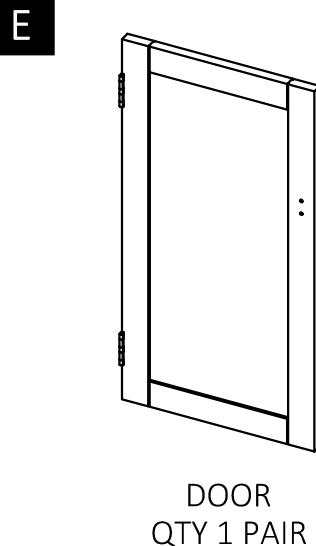
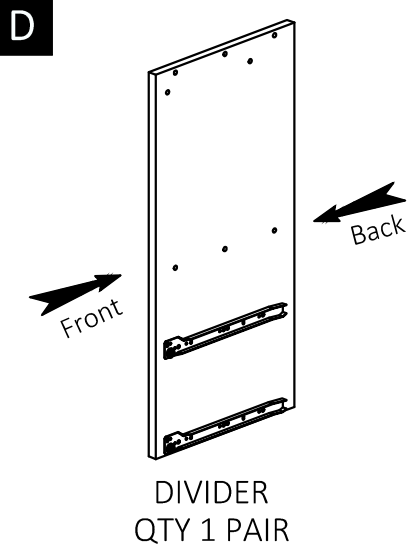
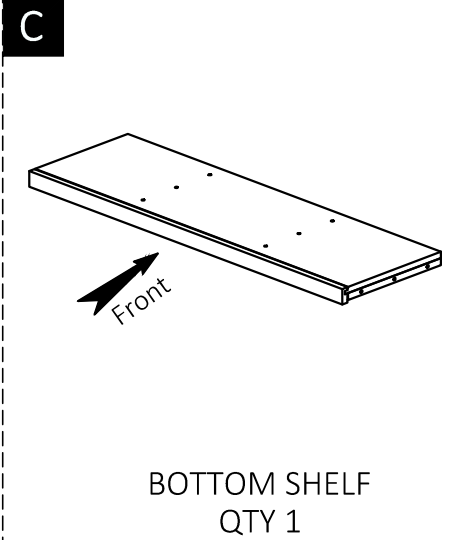
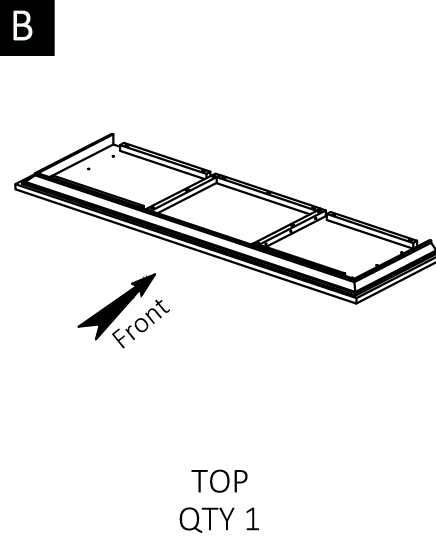
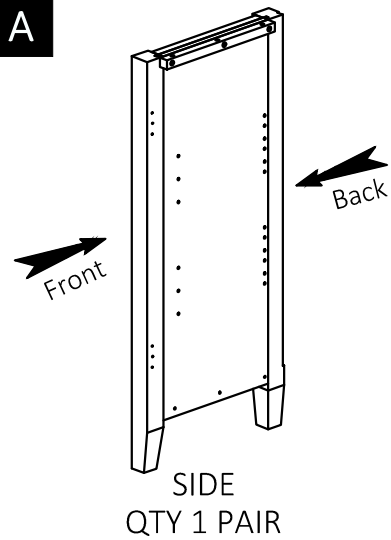

NEED HELP? For help with assembly or if you are missing a part,
Please call customer service

PRE-ASSEMBLY INFORMATION

PART DESCRIPTION

J

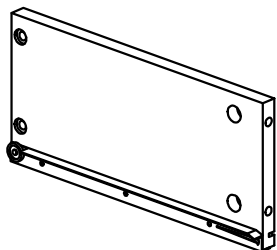

DRAWER SIDE
QTY 2 PAIRS

K

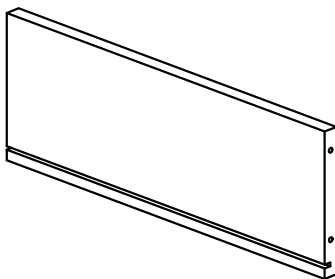

DRAWER BACK
QTY 2

L

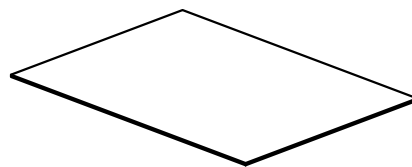

DRAWER BOTTOM
QTY 2

M

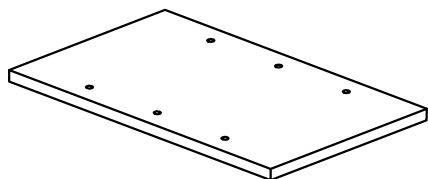

MIDDLE SHELF
QTY 2

N

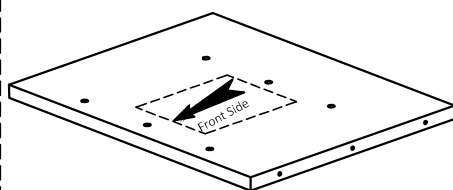

SHELF
QTY 1

O

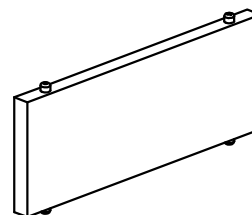

DIVIDER OF WINE RACK
QTY 9

NEED HELP? For help with assembly or if you are missing a part,
Please call customer service

PRE-ASSEMBLY INFORMATION

HARDWARE DESCRIPTION

1

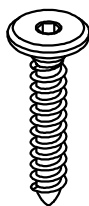

ALLEN KEY SCREW
M6 X 30mm
QTY 42

2



ALLEN KEY
QTY 1

3

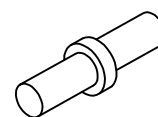

SHELF SUPPORT
QTY 24

4



PHILLIPS SCREW
M3 X 12mm
QTY 12

5



PHILLIPS SCREW
M3 X 15mm
QTY 16

6

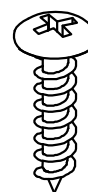

PHILLIPS SCREW
ROUND HEAD
M4 X 15mm
QTY 29

7

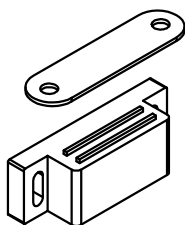

MAGNET AND PLATE
QTY 4 SETS

8

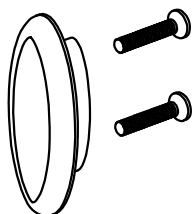

HANDLE
M4 X 22mm
QTY 2 SETS

9





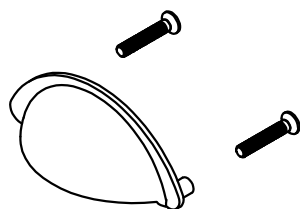

CAM LOCK PIN
CAM LOCK
QTY 8 SETS

10

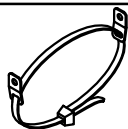

HANDLE
M4 X 10mm
QTY 2 SETS

11

- 
- a.  M4 X 25mm - QTY 1
b.  M4 X 15mm - QTY 1
c.  M4 X 25mm - QTY 1

FURNITURE ANTI-TIPPING
RESTRAINT
QTY 1 SET

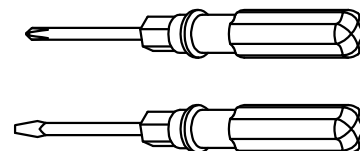

Required -
Flathead screwdriver
Phillips screwdriver
Not Included

NEED HELP? For help with assembly or if you are missing a part,
Please call customer service

COMPONENTS-KEY DIAGRAM

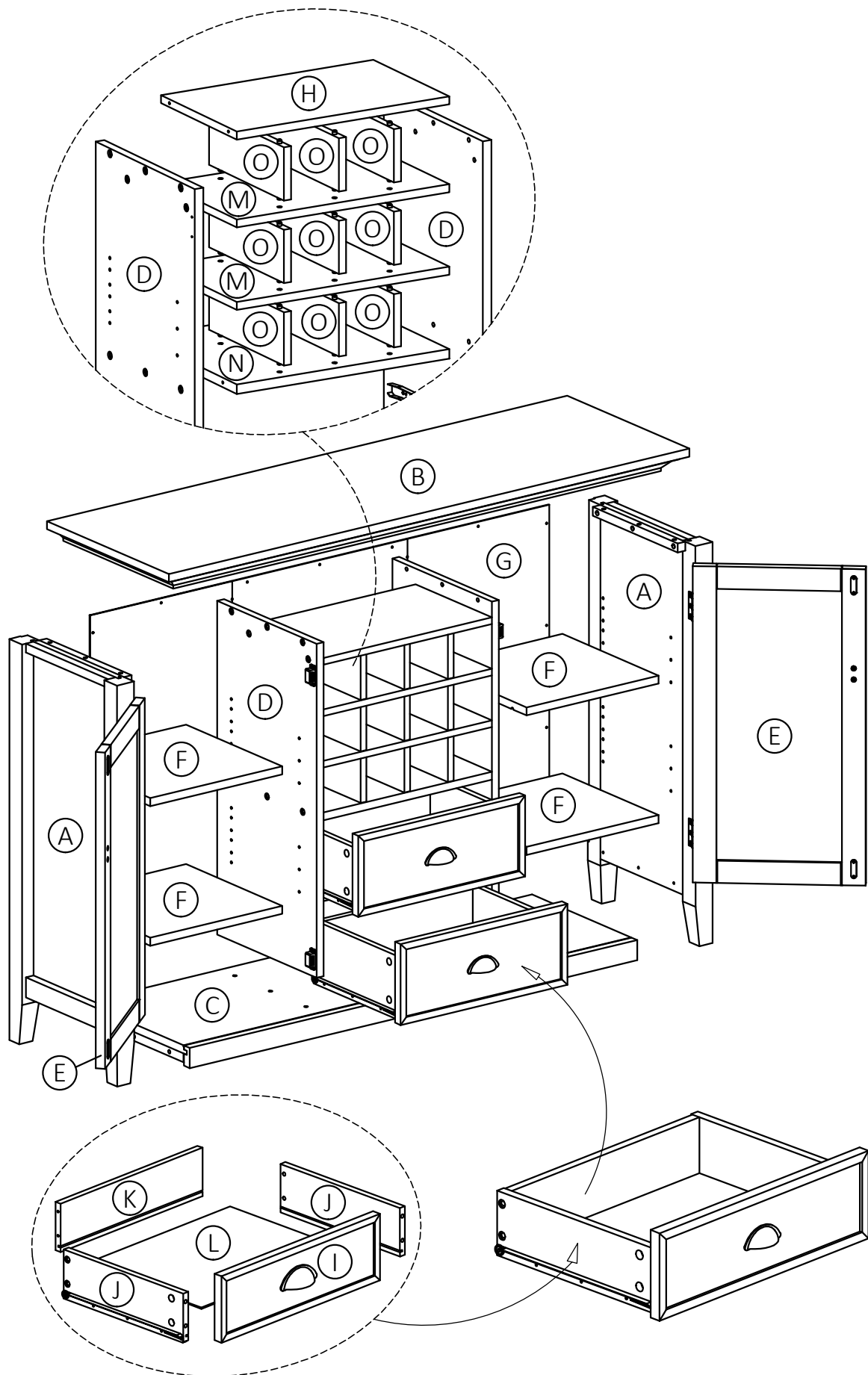

ASSEMBLY

STEP-1

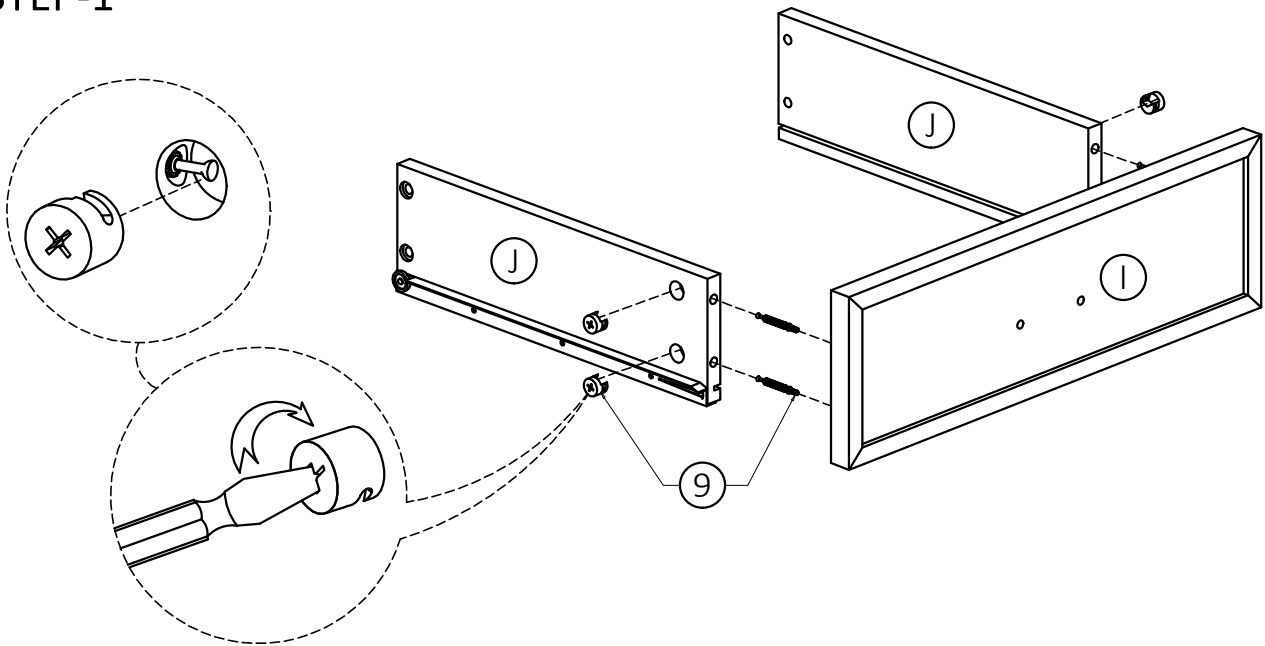

1. Attach four Cam Lock Pins (9) to back of Drawer Front (I).
2. Align Cam Lock Pins with pre-drilled holes and attach Drawer Sides (J).
3. Insert two Cam Locks (9) into pre-drilled holes on each Drawer Side (J).
4. Use flathead screwdriver to secure Cam Locks.

STEP-2

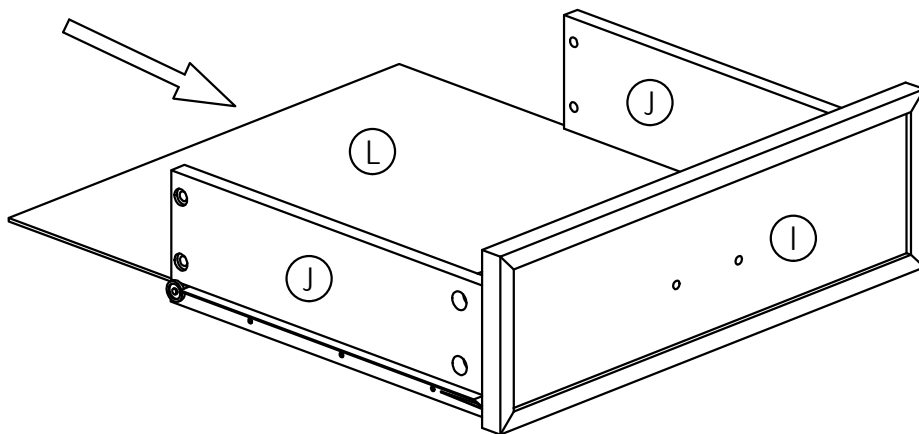

1. Slide Drawer Bottom (L) firmly into slots on Drawer Sides (J) and Drawer Front (I).

ASSEMBLY

STEP-3

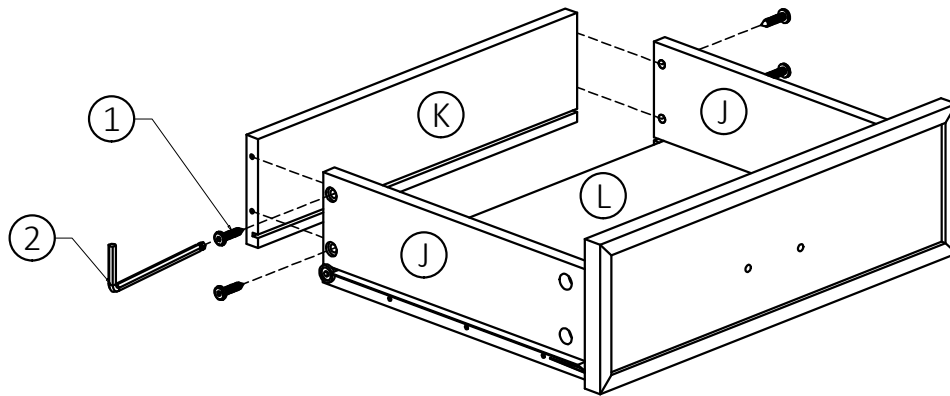

1. Align Drawer Back (K) with Drawer Bottom (L) and press firmly into slot.
2. Attach Drawer Back (K) using two Allen Key Screws (1) through pre-drilled holes on each Side (J).
3. Use Allen Key (2) to tighten Screws. Do not over-tighten.

STEP-4

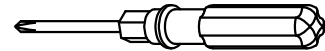
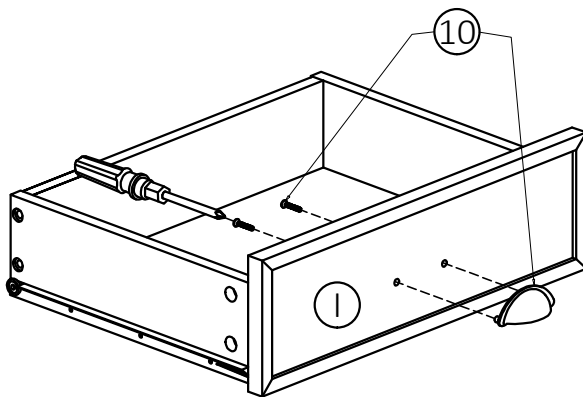

NOTE: The screwdriver is not included in the hardware pack.

1. Use phillips screwdriver to attach Handle (10) to Drawer Front (I).

Repeat Step 1 - 4 for the second drawer.

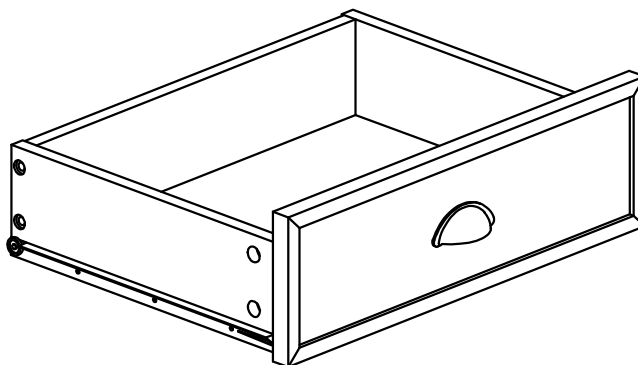

ASSEMBLY

STEP-5

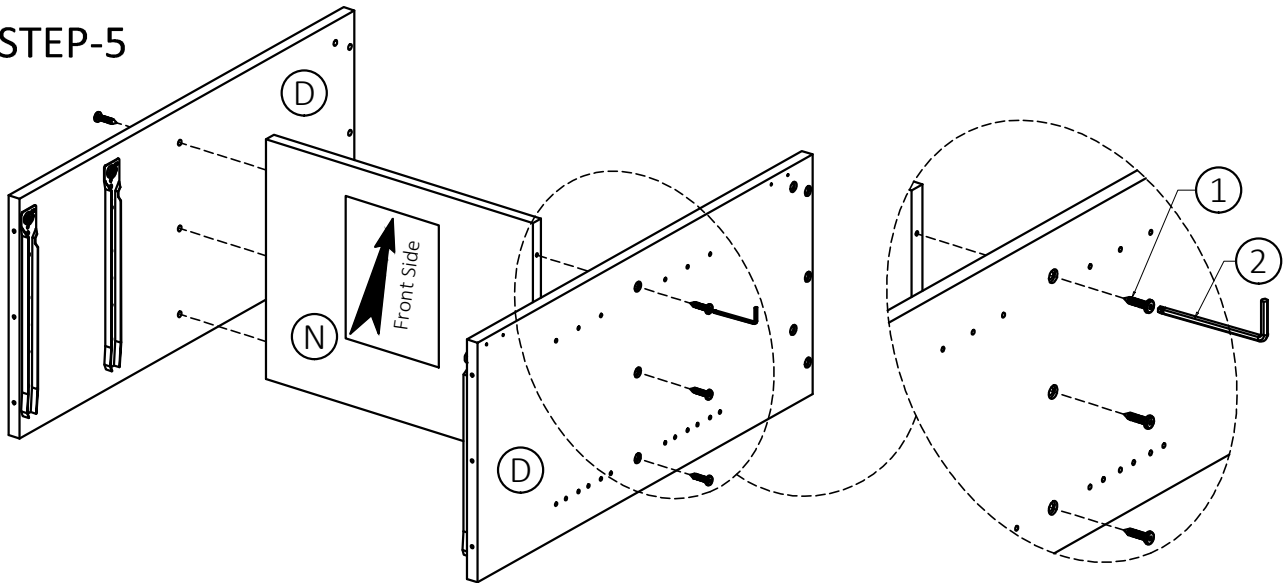

1. Attach Dividers (D) to Shelf (N) using six Allen Key Screws (1) (three screws on each Divider).
2. Use Allen Key (2) to tighten screws. Do not over-tighten.

STEP-6

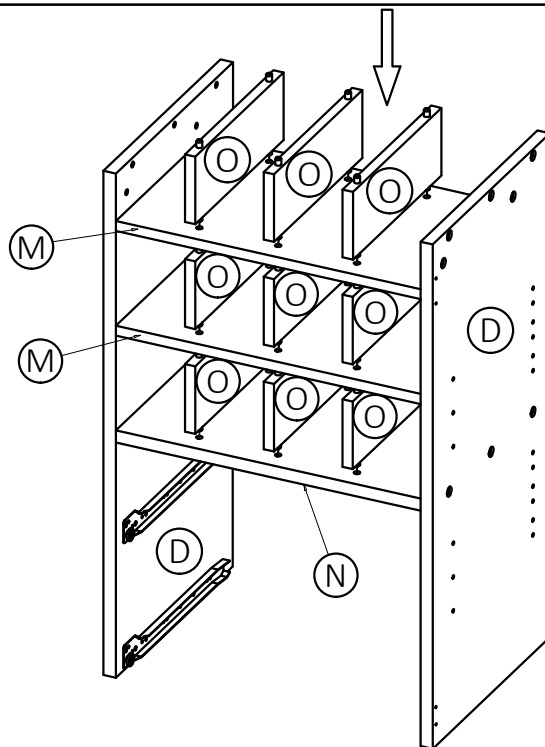

1. Attach three Dividers of Wine Rack (O) to Shelf (N) by aligning and inserting dowels in Dividers of Wine Rack (O) into pre-drilled holes on Shelf (N).
2. Align dowels on Dividers of Wine Rack (O) into pre-drilled holes on the bottom of Middle Shelf (M) and attach Middle Shelf (M).
3. Attach other three Dividers of Wine Rack (O) to Middle Shelf (M) by aligning and inserting dowels in Dividers of Wine Rack (O) into pre-drilled holes on Middle Shelf (M).
4. Align dowels on Dividers of Wine Rack (O) into pre-drilled holes on the bottom of Middle Shelf (M) and attach Middle Shelf (M).
5. Attach other three Dividers of Wine Rack (O) to Middle Shelf (M) by aligning and inserting dowels in Dividers of Wine Rack (O) into pre-drilled holes on Middle Shelf (M).

ASSEMBLY

STEP-7

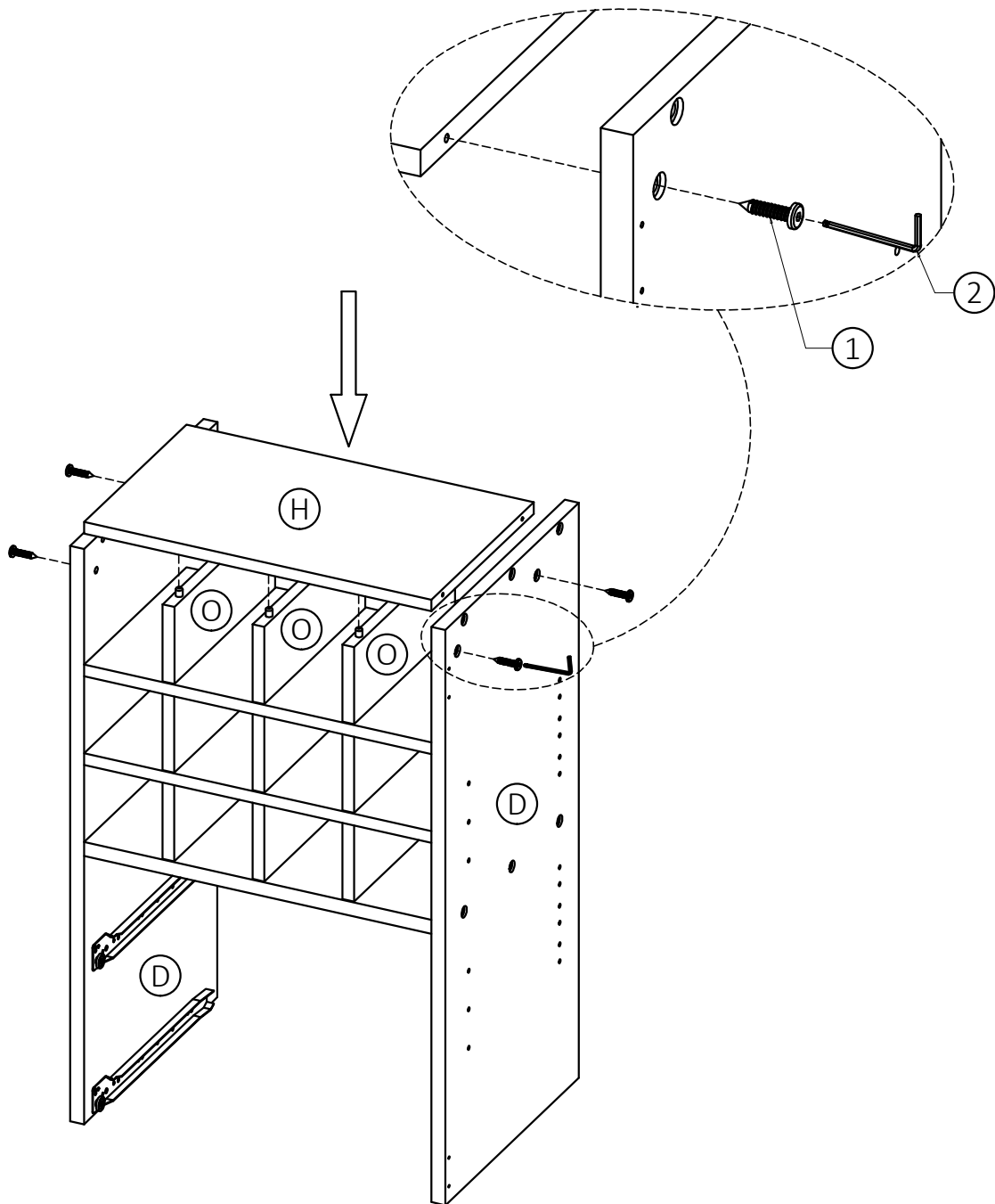

1. Align dowels on Dividers of Wine Rack (D) into pre-drilled holes on the bottom of Top Shelf (H) and attach Top Shelf (H).
2. Attach Top Shelf (H) to Dividers (D) using four Allen Key Screws (1) (two Screws on each Divider).
3. Use Allen Key (2) to tighten Screws. Do not over-tighten.

ASSEMBLY

STEP-8

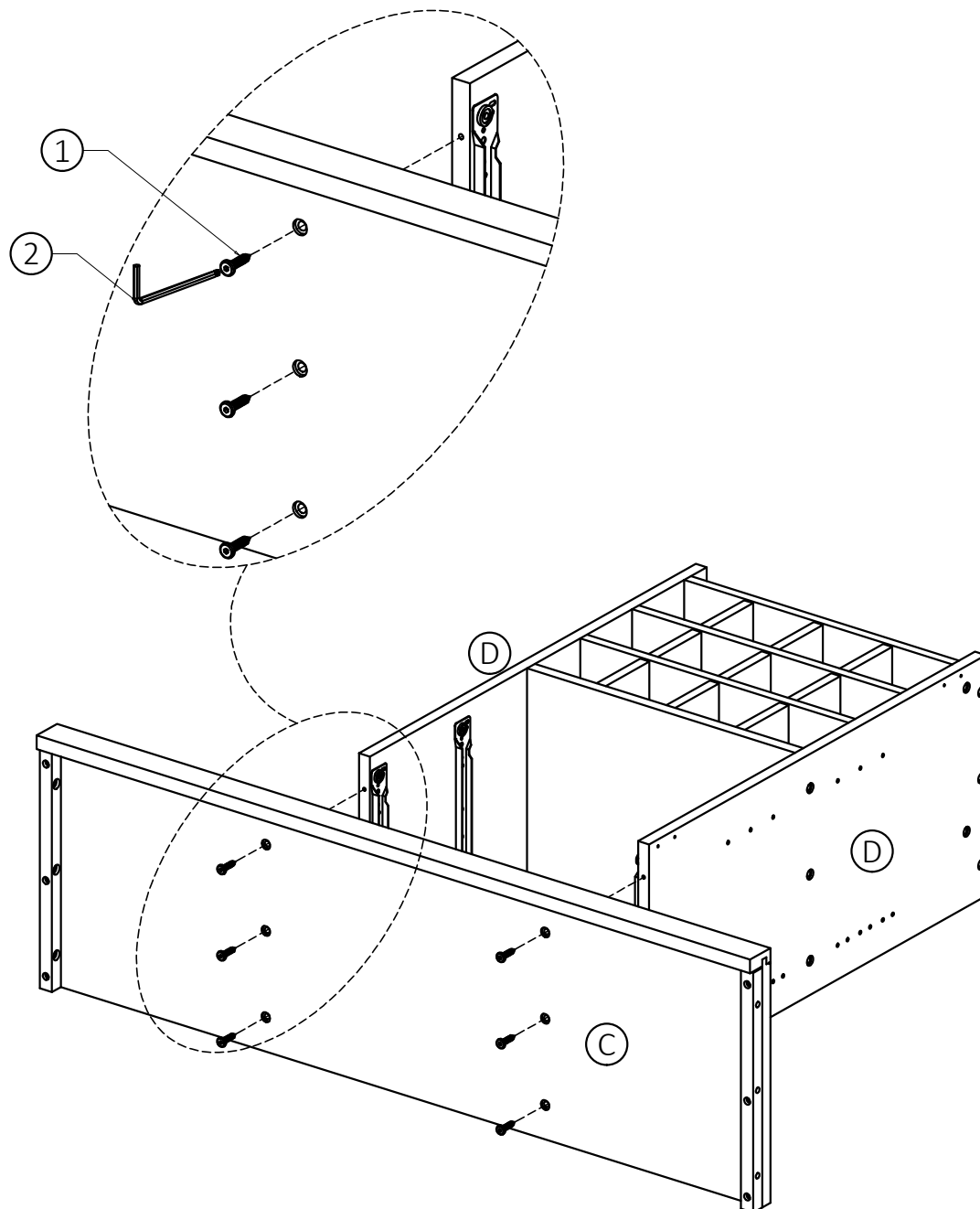

1. Attach Bottom Shelf (C) to Dividers (D) using six Allen Key Screws (1) (three screws on each Divider).
2. Use Allen Key (2) to tighten screws. Do not over-tighten.

ASSEMBLY

STEP-9

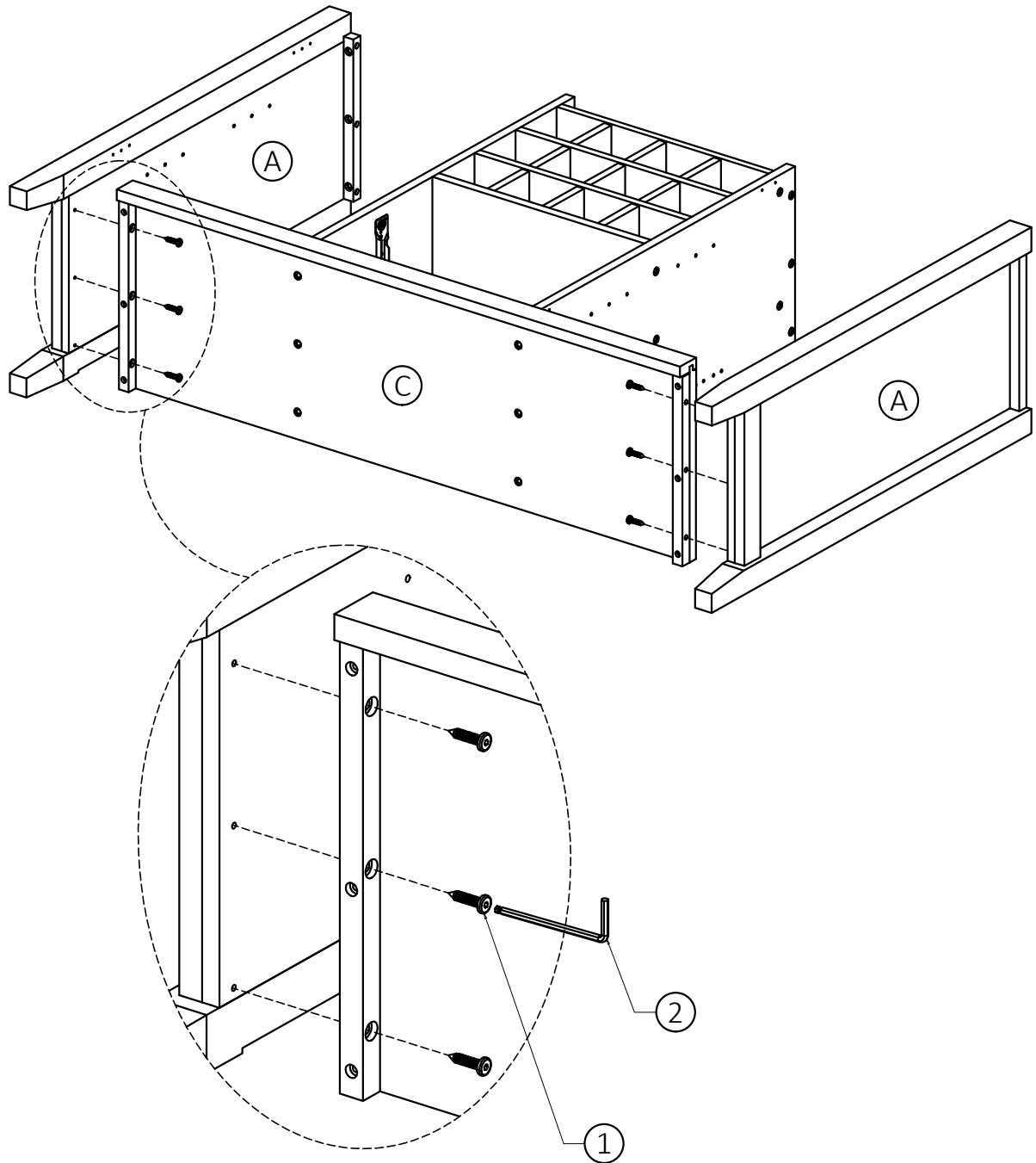

1. Attach Sides (A) to Bottom Shelf (C) using six Allen Key Screws (1) (three screws on each Side).
2. Use Allen Key (2) to tighten screws. Do not over-tighten.

ASSEMBLY

STEP-10

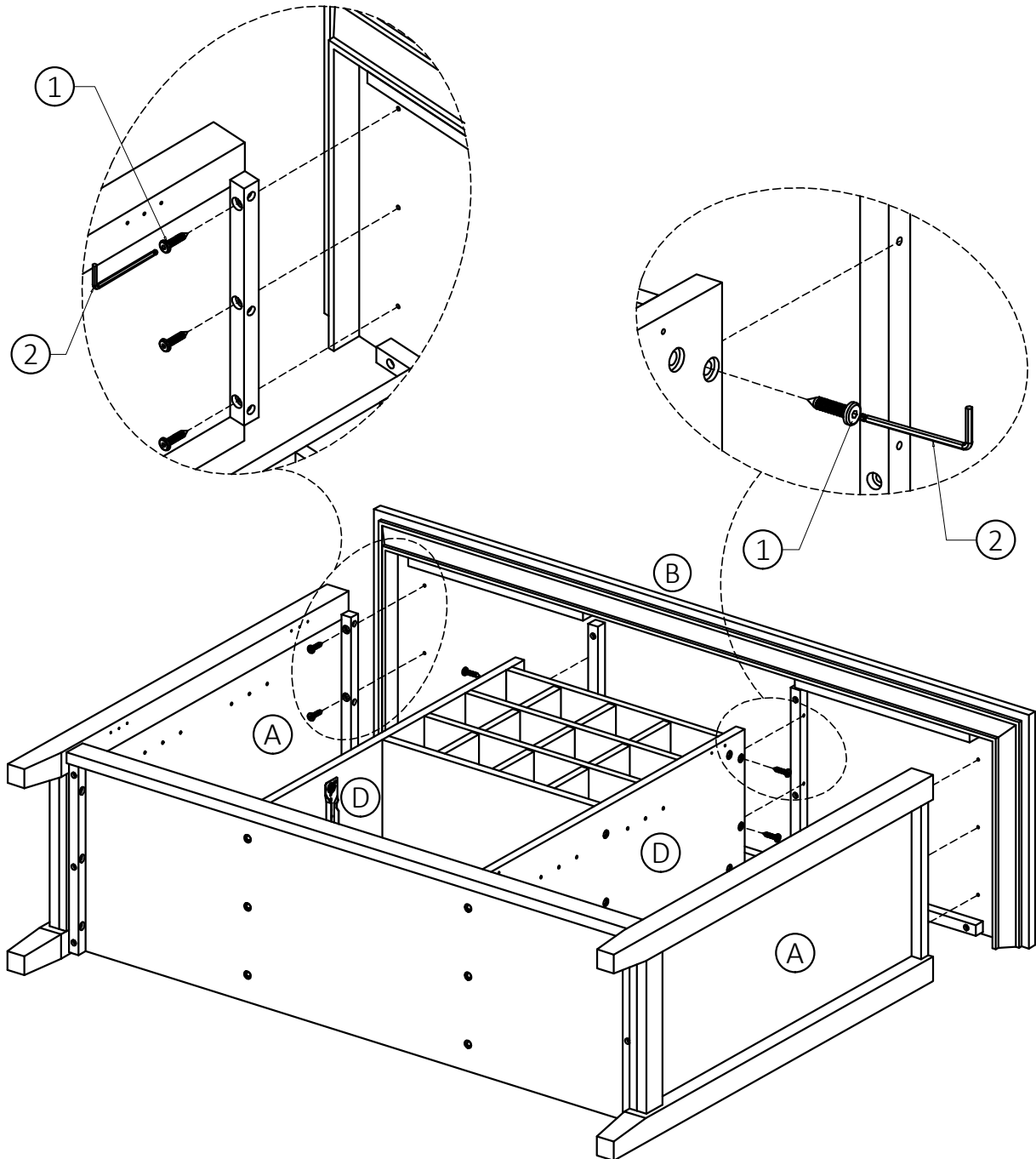

1. Attach Top (B) to Sides (A) and Dividers (D) using twelve Allen Key Screws (1) (three Screws on each Side and Divider).
2. Use Allen Key (2) to tighten screws. Do not over-tighten.

ASSEMBLY

STEP-11

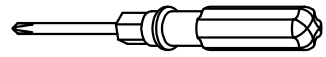

NOTE: The screwdriver is not included in the hardware pack.

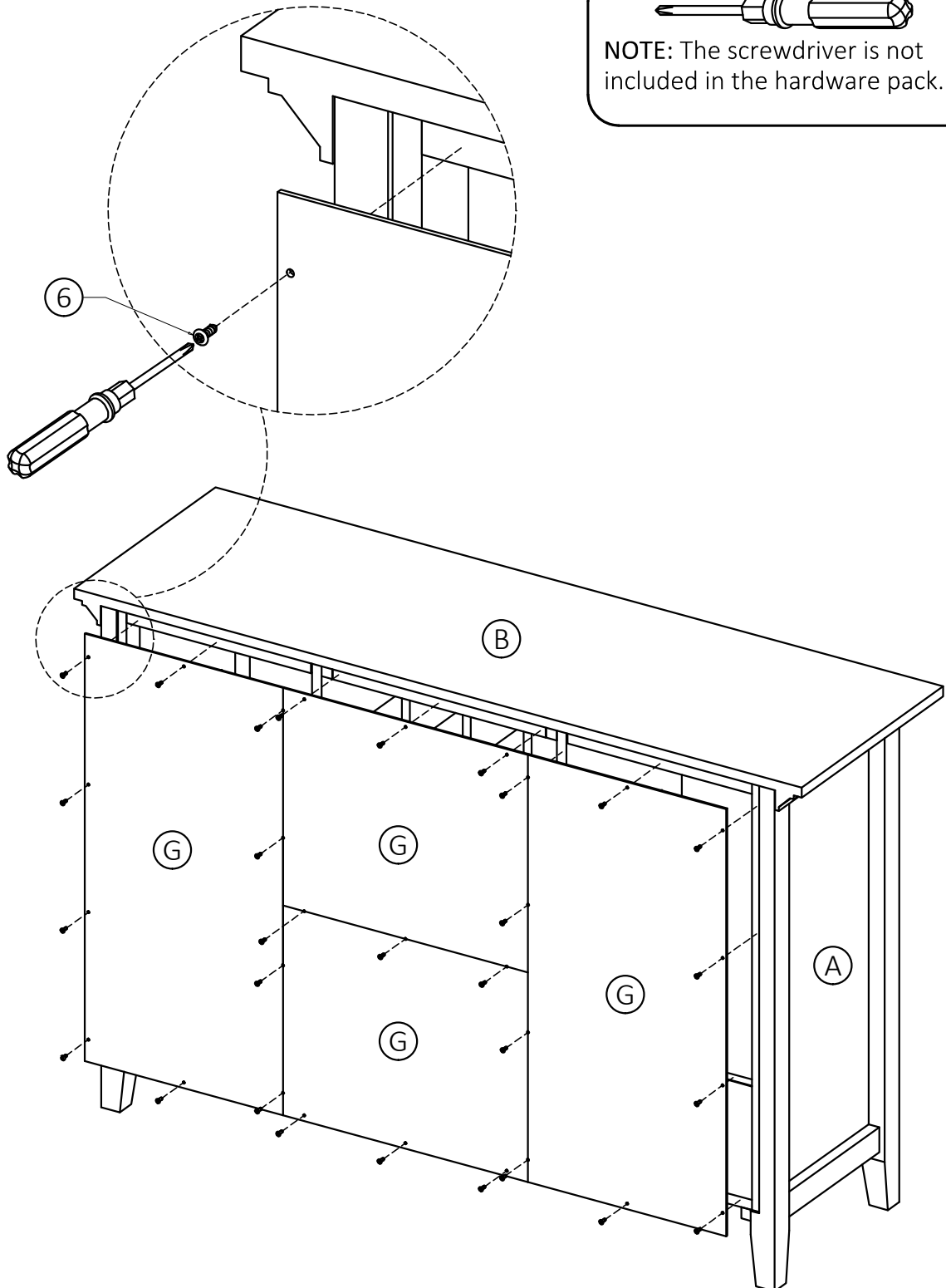

1. Attach Back Panels (G) to back frame of sideboard using twenty nine Phillips Screws Round Head (6) through pre-drilled holes.
2. Use Phillips Screwdriver to tighten screws.

ASSEMBLY

STEP-12

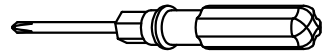

NOTE: The screwdriver is not included in the hardware pack.

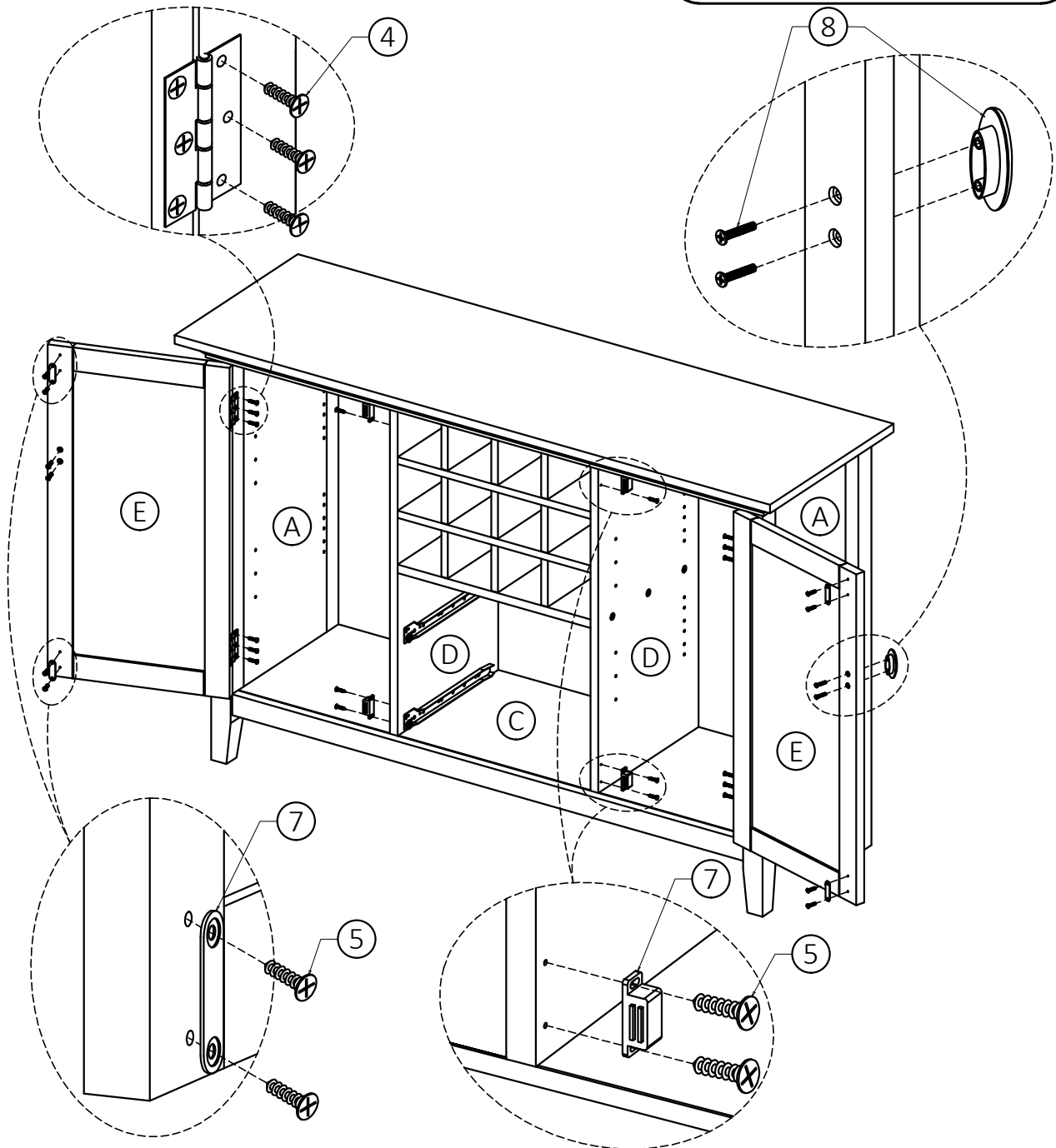

1. Attach hinges on Doors (E) to Sides (A) using Phillips Screws (4) into guide holes.
2. Attach Magnet Plates (7) to bottom corner of Doors (E) using Phillips Screws (5) into guide holes on Doors (E).
3. Attach Magnets (7) using Phillips Screws (5) into guide holes on Dividers (D).
4. Use Phillips screwdriver to snugly tighten screw.
5. Use Phillips screwdriver to attach Handle (8) to Doors (E).

ASSEMBLY

STEP-13

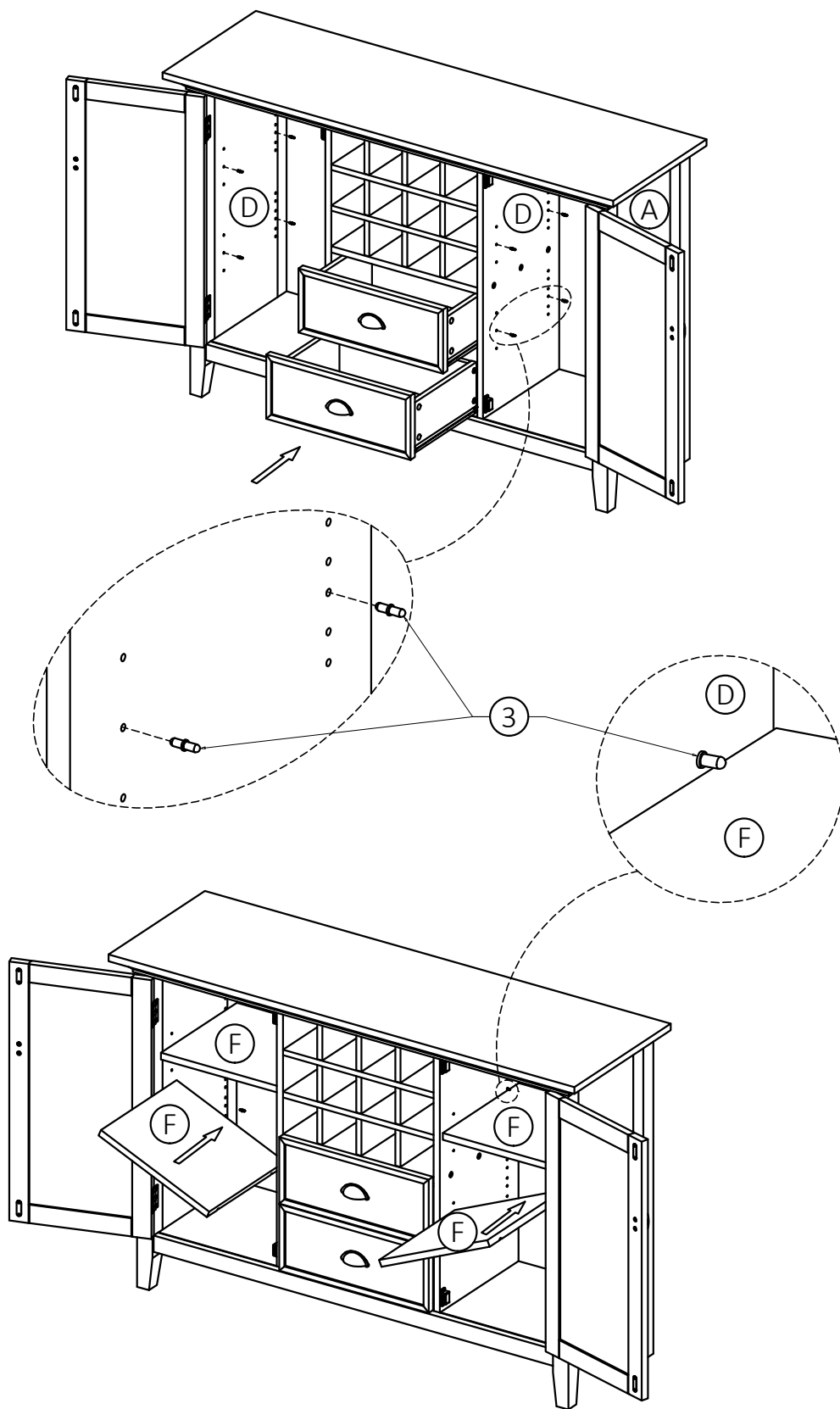

1. Use four Shelf Supports (3) for each Cabinet Shelf (F) in desired location.
2. Two Shelf Supports (3) may be used on back top of each Cabinet Shelf (F) as a tipping restraint.
3. Insert assembled drawers into glides on assembled sideboard.

FURNITURE ANTI-TIPPING RESTRAINT ASSEMBLY

NOTE: Injuries and damage can occur from furniture tip-over. It is important to use the safety bracket included. If the tipping restraint kit is not in the box, please contact our customer service department in order to obtain another kit before using the furniture.

STEP-14

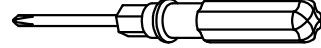

NOTE: The screwdriver is not included in the hardware pack.

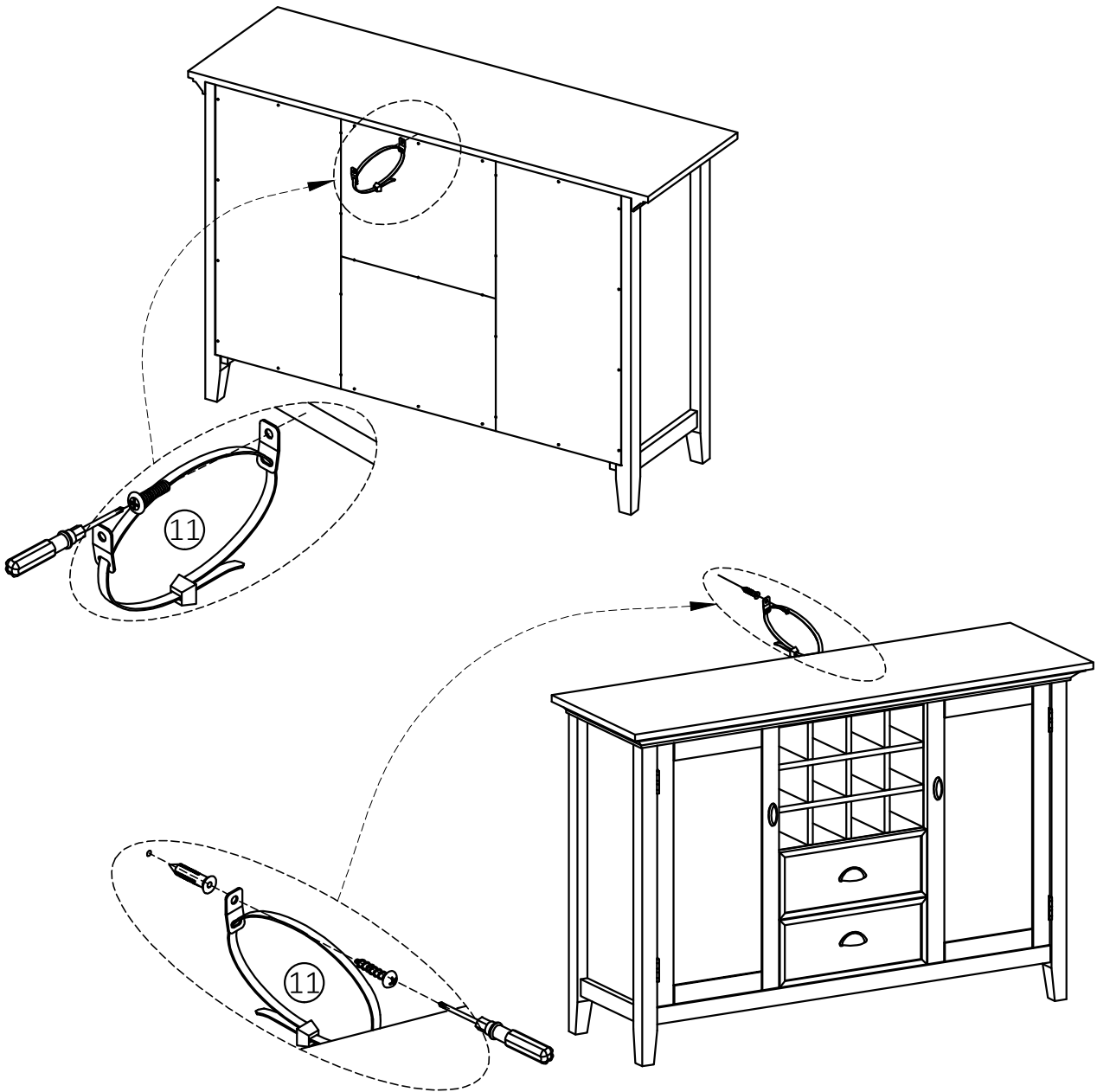

FURNITURE ANTI-TIPPING RESTRAINT ASSEMBLY

Furniture Anti-Tipping Restraint Instructions:

1. Attach one of the mounting brackets securely to the back edge of the furniture. Use the shorter screw.
 2. Determine where furniture is to be placed and mark location on the wall for mounting bracket screw hole approximately 2 inches below the bracket mounted to the furniture.
 3. Drill a 3/16 inch hole in the wall. Press the plastic anchor into the hole and gently tap until the flange on the anchor is against the wall surface.
 4. Position the bracket over the anchor and use the longer screw to securely attach the bracket to the wall.
 5. Place the furniture so the back edge is in line with the bracket on the wall.
 6. Lace an end of the nylon restraint down through each bracket. Bring both ends together and slide the beaded end of the strap through the keyhole shaped slot in the other end until snug. Pull down on the beaded end until it snap locks into the keyhole slot.
 7. To double lock, return the beaded end back through the keyhole as shown.
 8. Check to make sure the strap is securely laced and locked to the brackets.
- **DO NOT** put a TV or other heavy objects on top of a Sideboard Buffet & Wine Rack or any other furniture not intended for use with a TV
 - **DO NOT** place heavy objects in top drawers
 - **DO NOT** let children climb or hang on drawers, doors or shelves

WARRANTY

Thank you for purchasing a product. These products have been made to demanding, high-quality standards and are guaranteed for domestic use against manufacturing faults for a period of 12 months from the date of purchase. This warranty does not affect your statutory rights.

We reserve the right to repair or replace the defective product, at its discretion.

This product is guaranteed for 12 months if used for normal purposes. Any warranty is invalid if the product has been overloaded or subject to neglect, improper use or an attempted repair by other than an authorized agent. Heavy-duty or daily professional/commercial usage are not guaranteed.

Due to continuous product improvement, we reserve the right to change the product specifications without prior notice.