

Assembly Guide

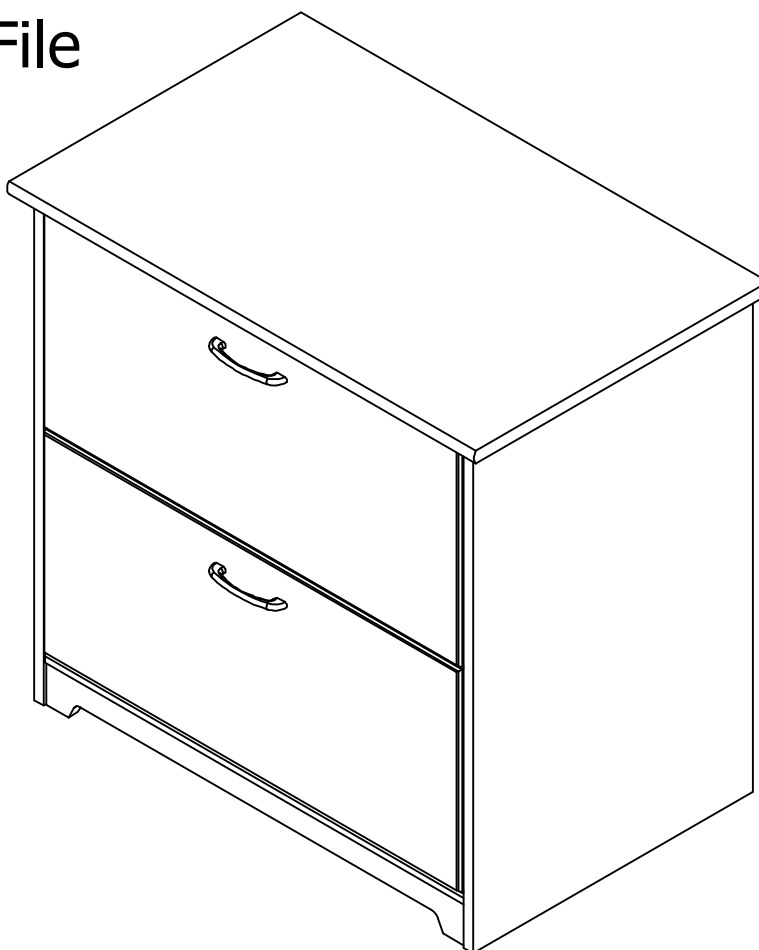

Lateral File



Get Ready to Assemble

For best results, keep these tips in mind:

- ① We know you want to finish this assembly as quickly as possible, but trust us: you'll have a better experience if you take it one step at a time.
- ② Give yourself some room to work near where you want the fully assembled product.
- ③ If your floor isn't carpeted, assemble this product on the empty carton to avoid scratching.
- ④ Do you have a friend who owes you a favor? Some steps may go a little easier with a second set of hands.

DOs

- ✔ Use a #2 Phillips head screwdriver (or other handheld tools as indicated)
- ✔ Wear safety glasses at all times during assembly
- ✔ Carefully follow the instructions in this guide and complete all steps in order
- ✔ Give us a call if you're having trouble with a particularly tricky step

DON'Ts

- ✘ We know power tools are quick and easy, but you shouldn't use them when assembling this product (unless otherwise specified)
- ✘ Never move your furniture with items inside or resting on the surface
- ✘ Do not attempt to use this product before all steps have been completed

IMPORTANT SAFETY INFORMATION



PLEASE READ WARNINGS

Improper use can cause safety hazards, or damage to your furniture and household items.

Warning	Do	Don't	Why it's important
Serious injury may occur.	<ul style="list-style-type: none">Assemble following all instructions using all indicated parts and hardware provided.Verify furniture is stable on it's own. Place heaviest items in the lower drawers.Always load the bottom drawer first. Check before using that only one drawer opens at a time.Evenly distribute files front to back. If so equipped, extend front levelers 1/4" more than rear levelers so unit tilts slightly rearward."	<ul style="list-style-type: none">Do not load with a television or other heavy equipment.Do not exceed the maximum load limits stated in the instructions.Do not allow children to stand, climb, or hang on furniture."	<ul style="list-style-type: none">Improper assembly, use or loading can lead to product instability, tip-over or collapse.
Serious injury may occur.	<ul style="list-style-type: none">Properly install and maintain the anti-tip mechanism.		<ul style="list-style-type: none">The anti-tip mechanism prevents more than one drawer from being opened at once which may lead to instability or product tip-over.

Caution	Do	Don't	Why it's important
Injury may occur.	<ul style="list-style-type: none">Unload unit prior to moving starting with top drawer first.	<ul style="list-style-type: none">Do not move unit when loaded.	<ul style="list-style-type: none">Loaded units are heavy and are not designed to be moved when loaded.

IMPORTANT SAFETY INFORMATION



PLEASE READ WARNINGS

Improper use can cause safety hazards, or damage to your furniture and household items.

Advertencia	Hacer	No	Por qué es importante
Se pueden producir lesiones graves.	<ul style="list-style-type: none">• Ensamble siguiendo todas las instrucciones utilizando todas las piezas y ferretería indicados provistos.• Verifique que los muebles sean estables por sí mismos.• Coloque los artículos más pesados en los cajones inferiores.• Siempre cargue primero el cajón inferior.• Compruebe antes de usar que solo se abre un cajón a la vez.• Distribuya uniformemente los archivos de adelante hacia atrás. Si está equipado, extienda los niveladores delanteros 1/4 " "más que los niveladores traseros para que la unidad se incline ligeramente hacia atrás."	<ul style="list-style-type: none">• No cargue con un televisor u otro equipo pesado. No exceda los límites máximos de carga establecidos en las instrucciones.• No permita que los niños se paren, trepen o cuelguen de muebles.	<ul style="list-style-type: none">• El ensamblaje, uso o carga inadecuados pueden provocar inestabilidad del producto, vuelco o colapso.
Se pueden producir lesiones graves.	<ul style="list-style-type: none">• Instale y mantenga adecuadamente el mecanismo antivuelco.		<ul style="list-style-type: none">• El mecanismo antivuelco evita que se abra más de un cajón a la vez, lo que puede provocar inestabilidad o vuelco del producto.

Atención	Hacer	No	Por qué es importante
Se pueden producir lesiones.	<ul style="list-style-type: none">• Descargue la unidad antes de moverla, comenzando primero con el cajón superior.	<ul style="list-style-type: none">• No mueva la unidad cuando esté cargada.	<ul style="list-style-type: none">• Las unidades cargadas son pesadas y no están diseñadas para moverse cuando están cargadas.

IMPORTANT SAFETY INFORMATION



PLEASE READ WARNINGS

Improper use can cause safety hazards, or damage to your furniture and household items.

Avertissement	Faire	Ne le fais pas	Pourquoi c'est important
Des blessures graves peuvent survenir.	<ul style="list-style-type: none">• Assemblez en suivant toutes les instructions en utilisant toutes les pièces et le matériel indiqués fournis.• Vérifiez que les meubles sont stables par eux-mêmes.• Placez les objets les plus lourds dans les tiroirs inférieurs.• Chargez toujours le tiroir inférieur en premier.• Vérifiez avant d'utiliser qu'un seul tiroir s'ouvre à la fois.• Répartissez uniformément les fichiers d'avant en arrière.• Si tel est le cas, déployez les niveleurs avant de 1/4 po de plus que les niveleurs arrière afin que l'appareil s'incline légèrement vers l'arrière.	<ul style="list-style-type: none">• Ne chargez pas avec un téléviseur ou un autre équipement lourd. Ne dépassez pas les limites de charge maximale indiquées dans les instructions.• Ne laissez pas les enfants se tenir debout, grimper ou s'accrocher aux meubles.	<ul style="list-style-type: none">• Un assemblage, une utilisation ou un chargement incorrects peuvent entraîner une instabilité du produit, un renversement ou un effondrement.
Des blessures graves peuvent survenir.	<ul style="list-style-type: none">• Installez et entretenez correctement le mécanisme anti-basculement.		<ul style="list-style-type: none">• Le mécanisme anti-basculement empêche l'ouverture simultanée de plusieurs tiroirs, ce qui peut entraîner une instabilité ou un renversement du produit.

Attention	Faire	Ne le fais pas	Pourquoi c'est important
Des blessures graves peuvent survenir.	<ul style="list-style-type: none">• Déchargez l'unité avant de déplacer en commençant par le tiroir supérieur en premier.	<ul style="list-style-type: none">• Ne déplacez pas l'unité lorsqu'elle est chargée.	<ul style="list-style-type: none">• Les unités chargées sont lourdes et ne sont pas conçues pour être déplacées lorsqu'elles sont chargées.

Get to know your Boards

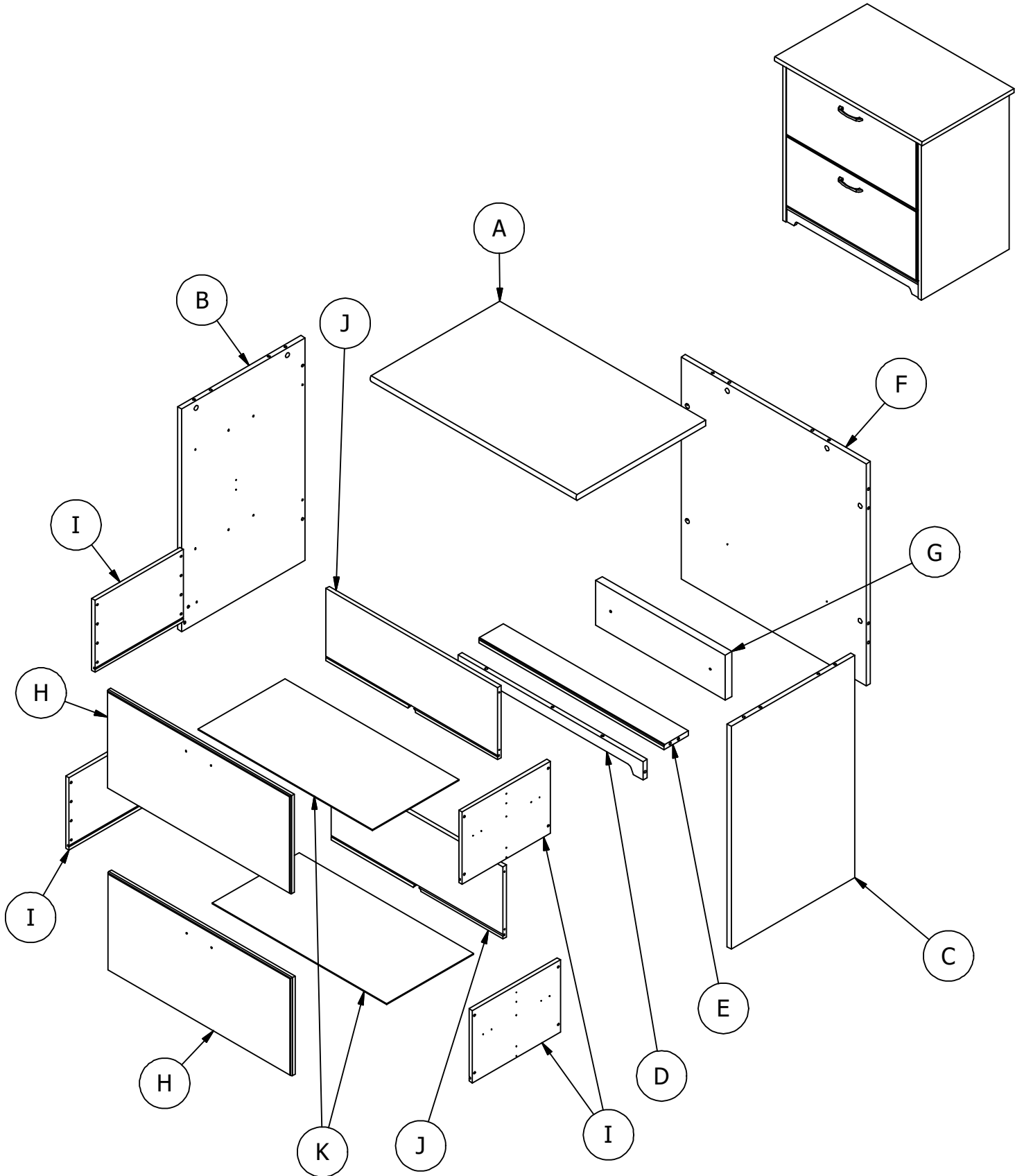

Get to know your Fasteners

Fasteners are shown actual size.

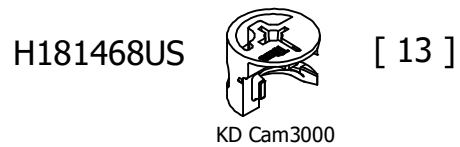
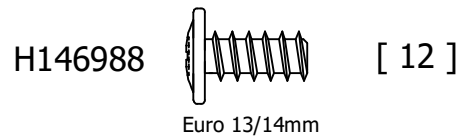
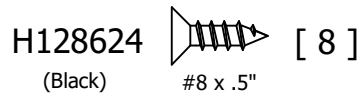
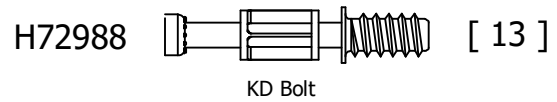
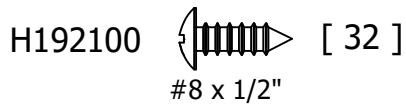
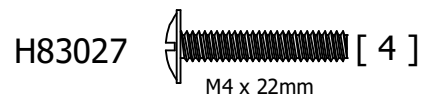
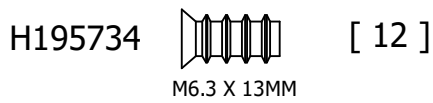
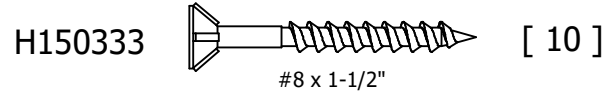
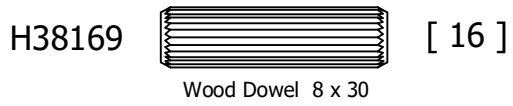

Get to know your Hardware

Hardware not to scale.

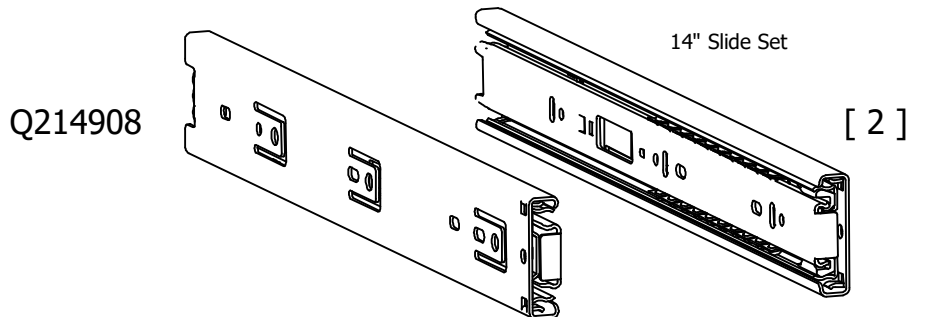
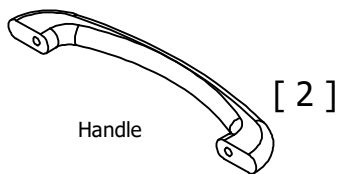
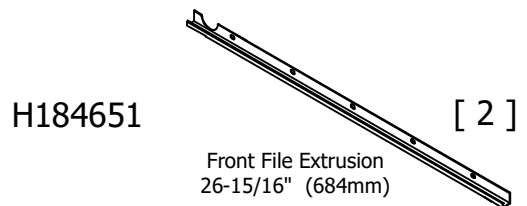
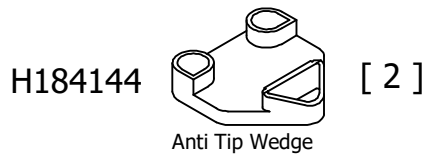
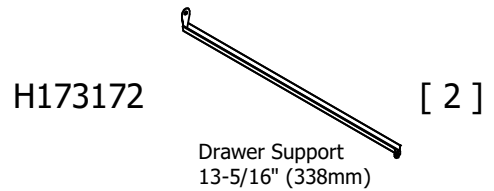
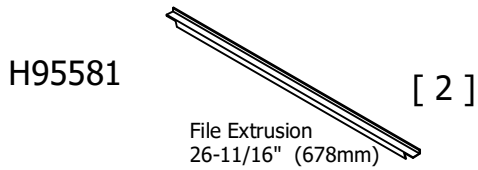
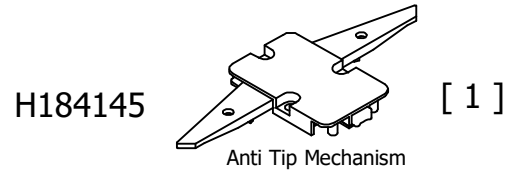
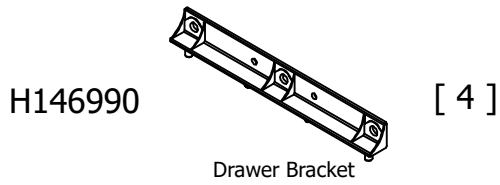
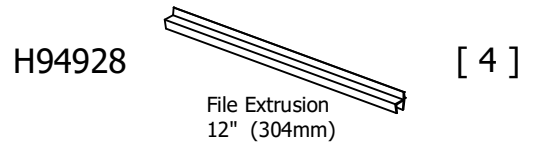
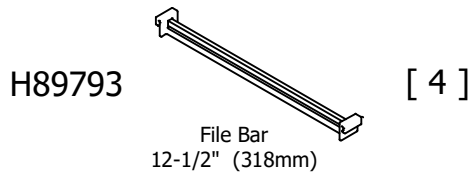

STEP 1

Prepare Panels

H146988 [12]
Euro 13/14mm

H146990 [4]
Drawer Bracket

H83027 [4]
M4 x 22mm

Handle [2]

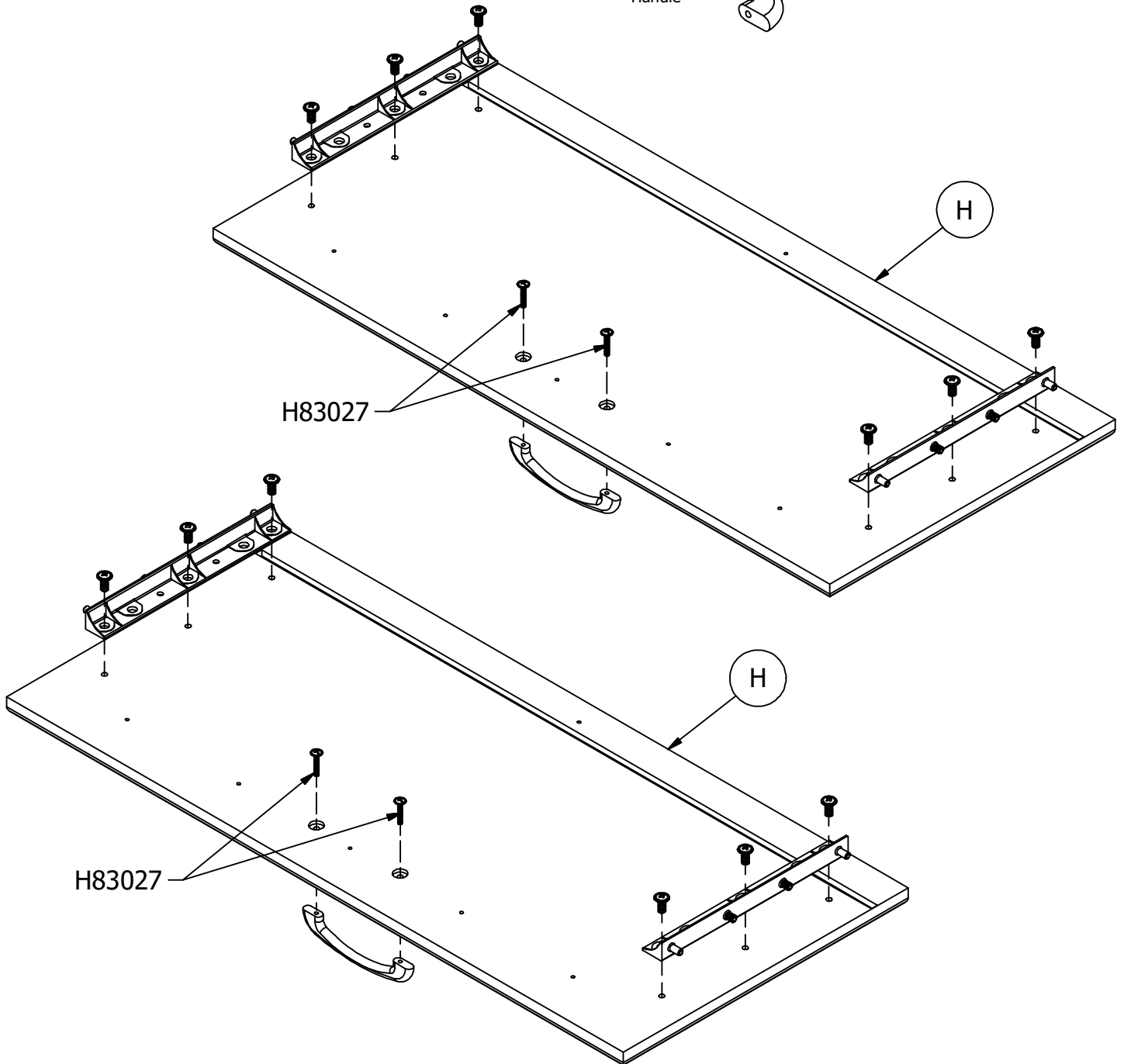

STEP 2

Prepare Panels

H192100 [10]
#8 x 1/2"

H184651

[2]

Front File Extrusion
26-15/16" (684mm)

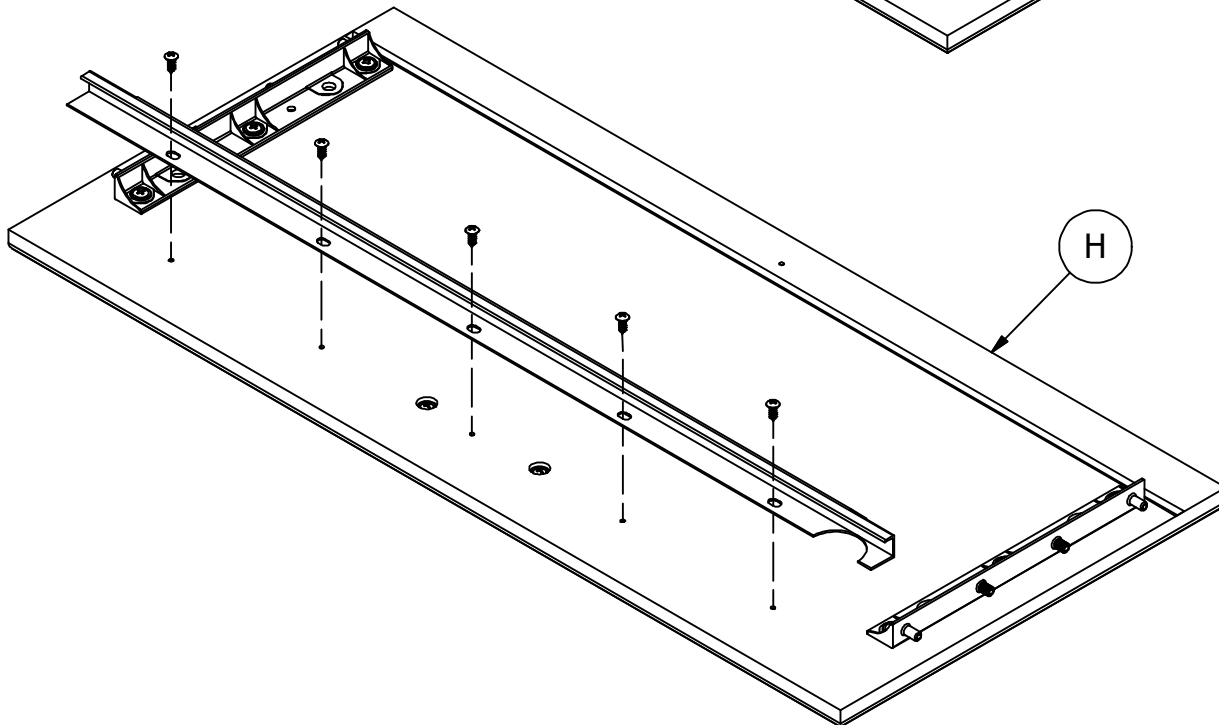
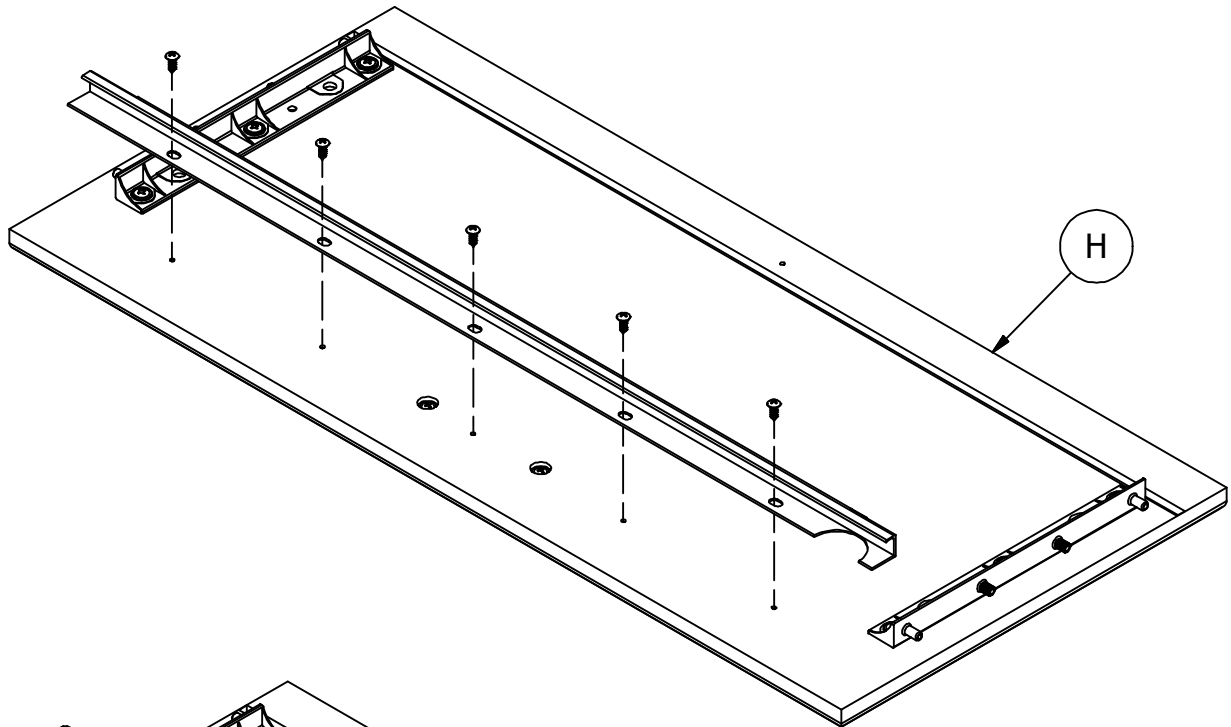
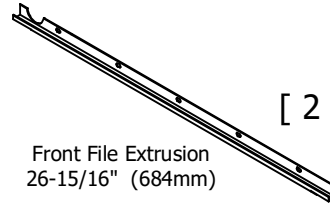

STEP 3

Assemble Drawers

H128624 [8]
(Black) #8 x .5"

H150333 [8]
#8 x 1-1/2"

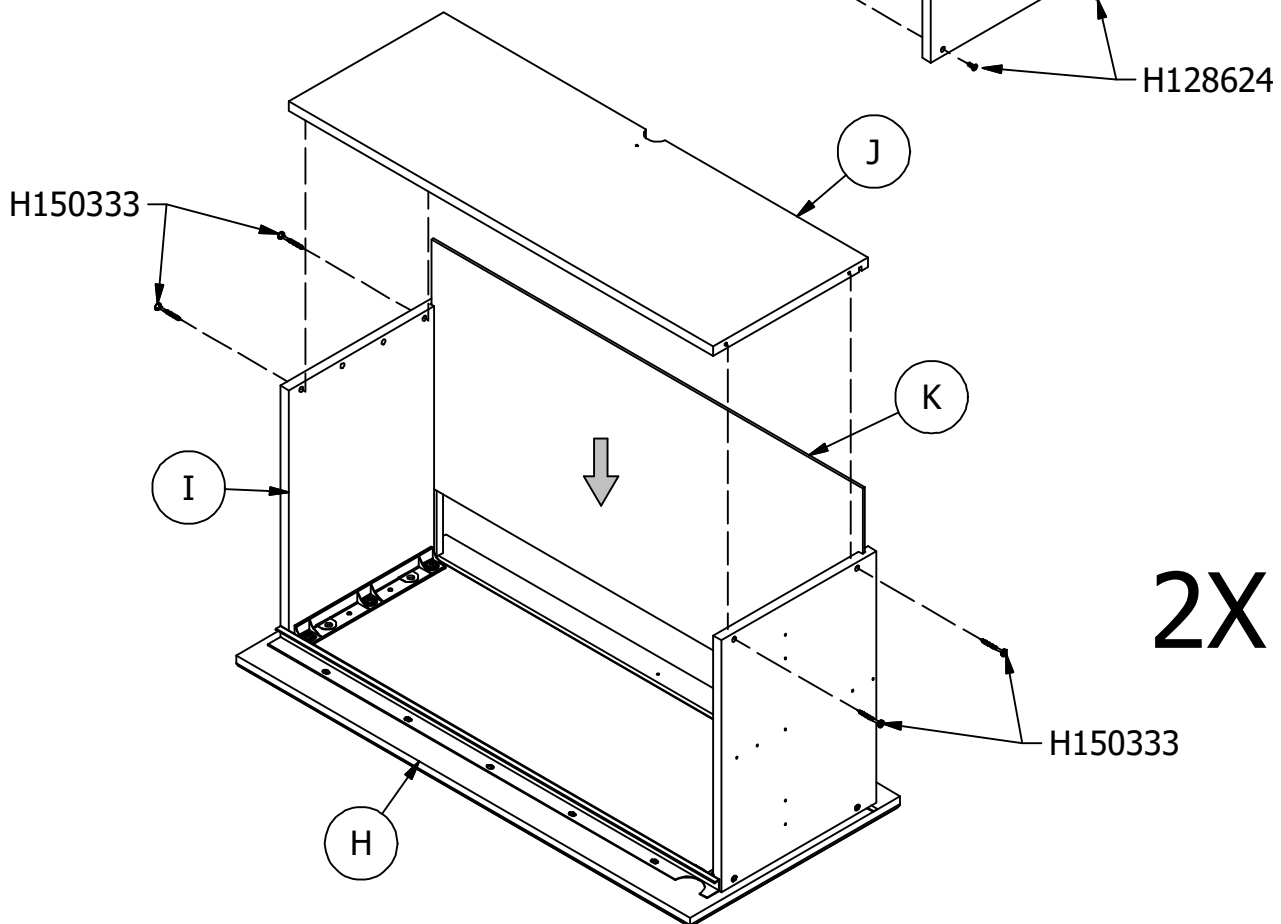
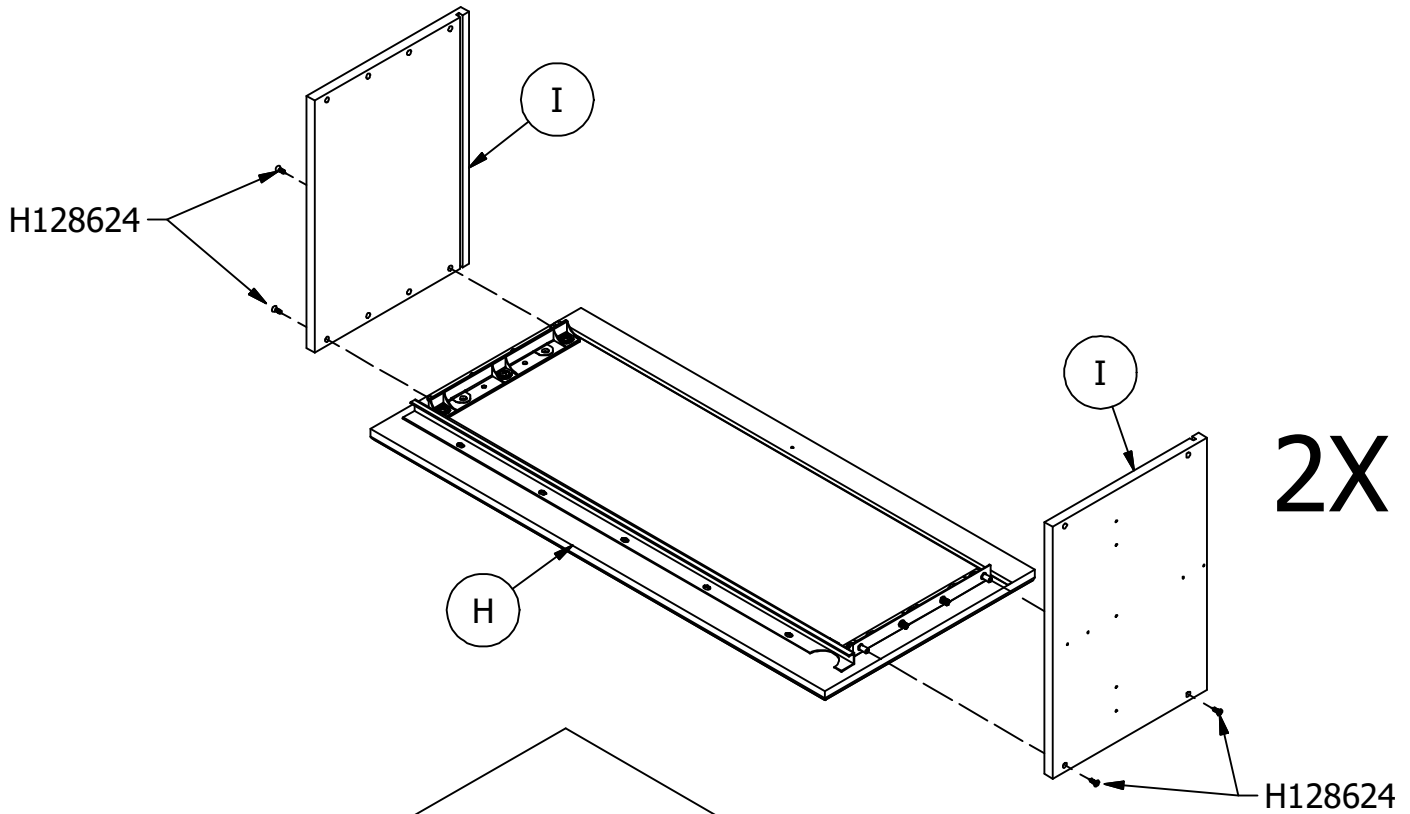

STEP 4

Attach Hardware

H192100 [4]
#8 x 1/2"

H173172 [2]
Drawer Support
13-5/16" (338mm)

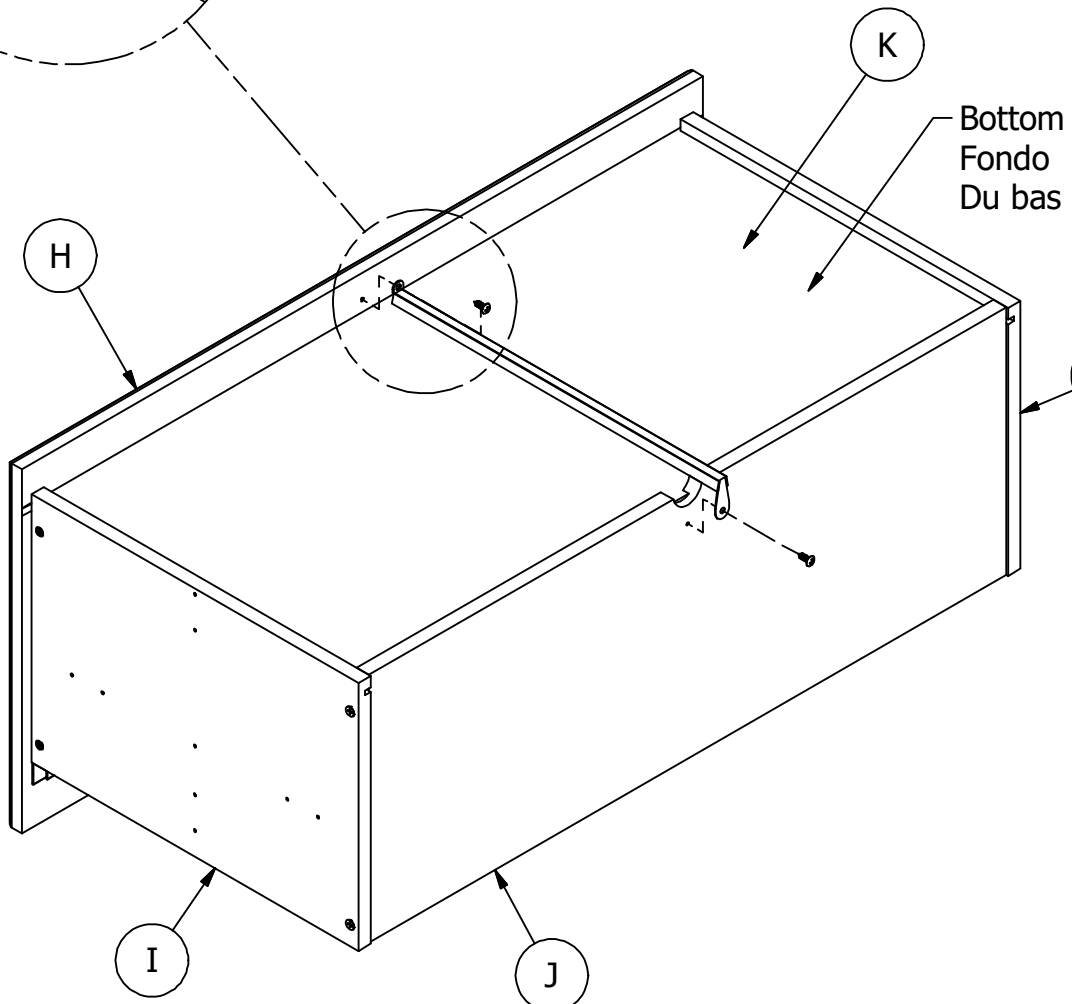
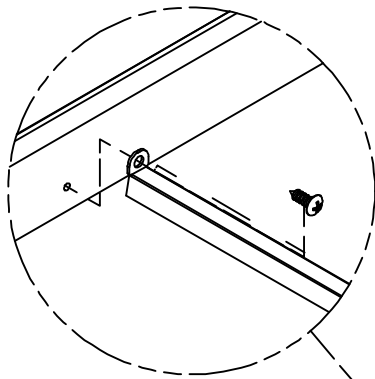

2x

STEP 5

Separate Slides

Scan QR Code to Watch Video on:



How to Separate and Install Drawer Slides

**Slides Must Be Separated Before Assembly.
After Separated, Set Aside Until Needed for Assembly.**

Las diapositivas deben separarse antes del montaje.
Después de la separación, déjelo a un lado hasta que sea necesario.

Les glissières doivent être séparées avant l'assemblage.
Après la séparation, mettez de côté jusqu'au moment de l'assemblage.

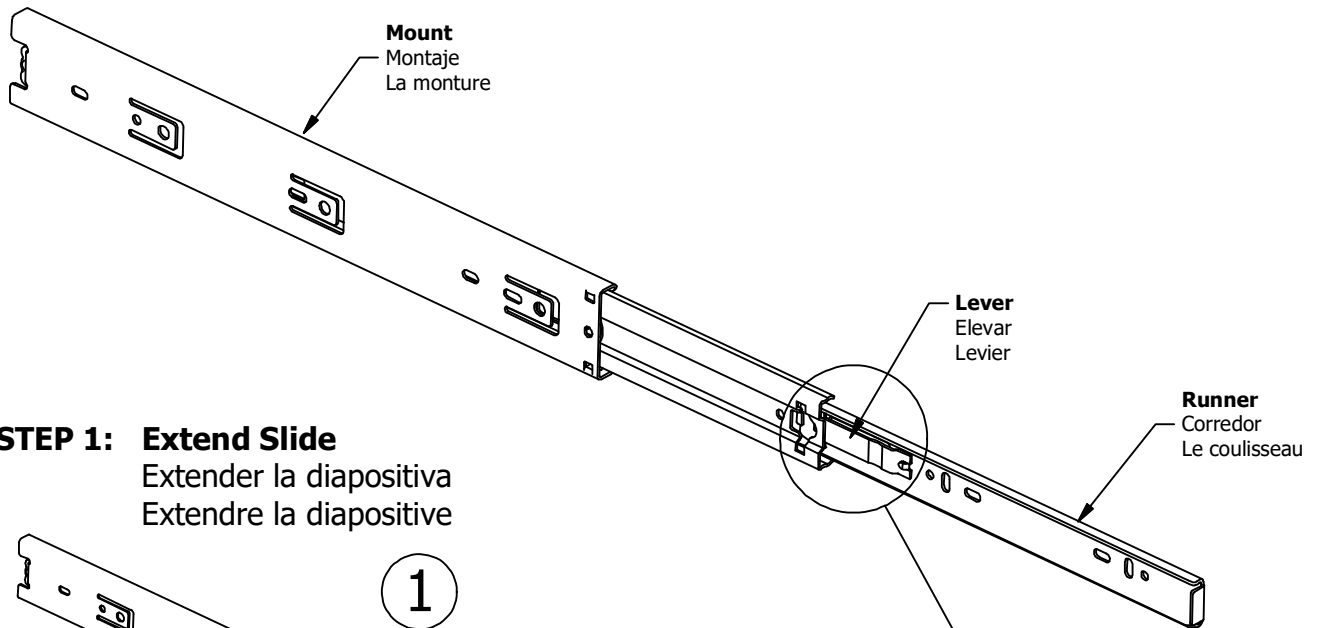

STEP 1: Extend Slide
Extender la diapositiva
Extendre la diapositive

1

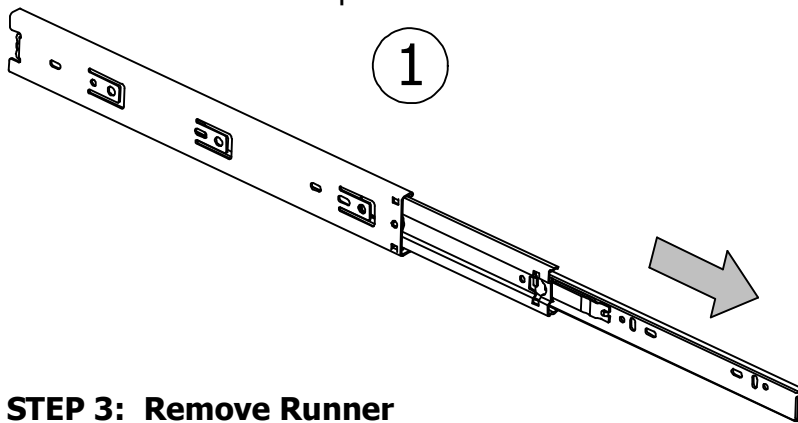

STEP 3: Remove Runner
Quitar el corredor
Enlever le coureur

2

3

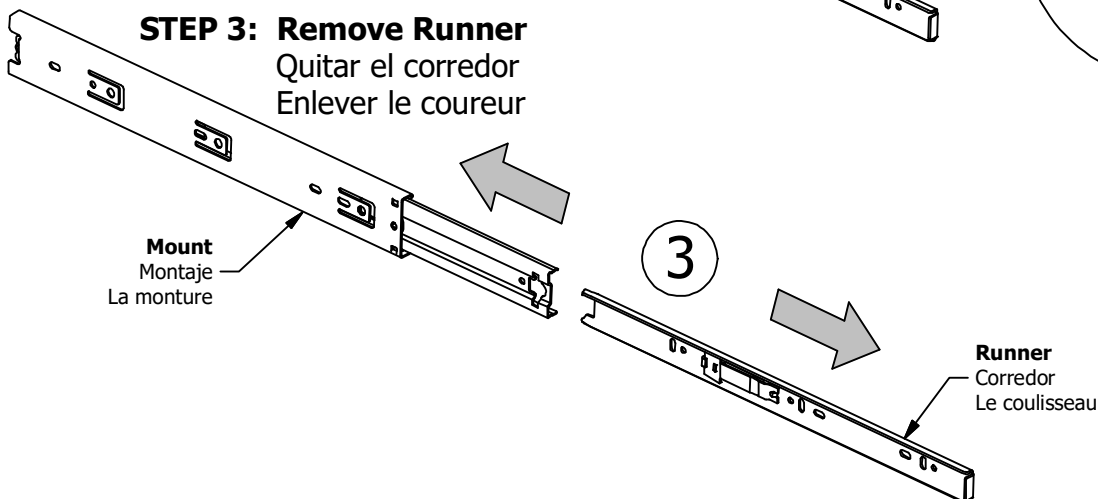

STEP 6

Attach Hardware

Scan QR Code to Watch Video on:



How to Separate and Install Drawer Slides

H192100  [12]
#8 x 1/2"

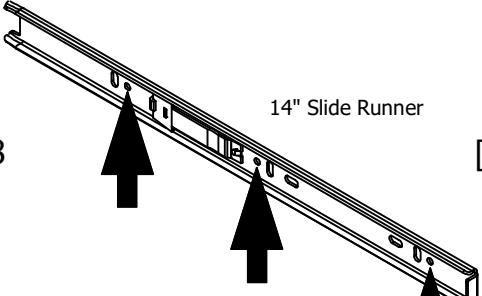
Q214908  14" Slide Runner [4]

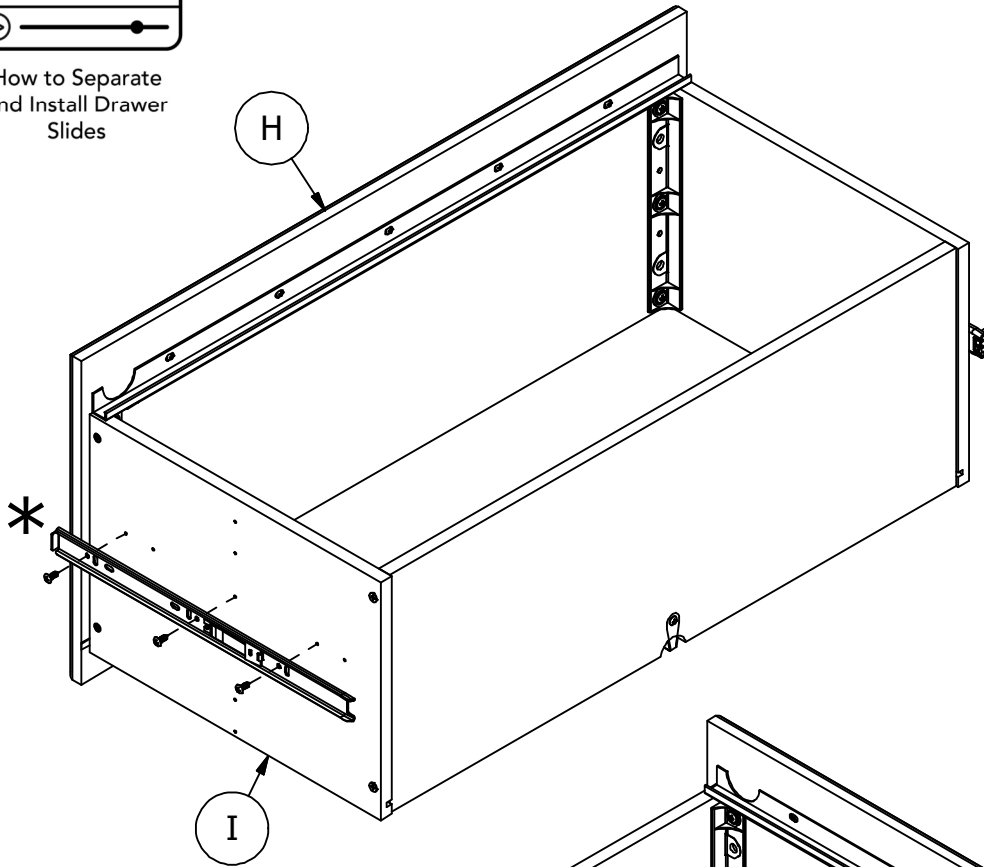

2X

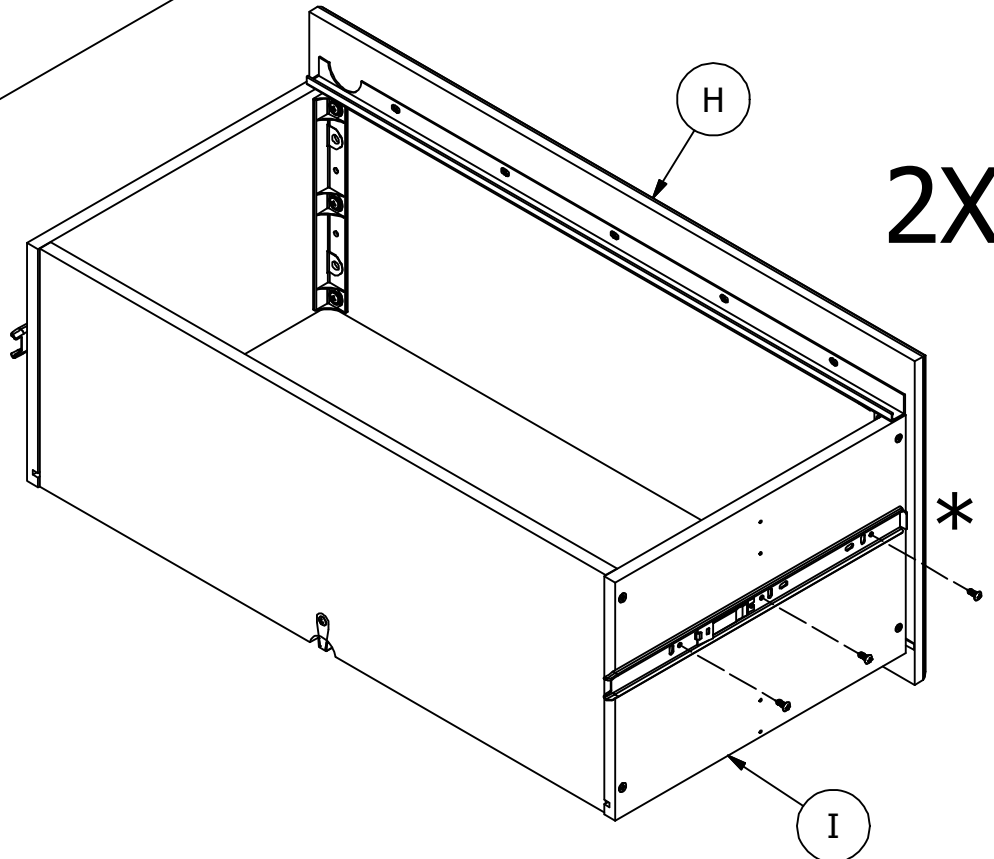

2X

STEP 7

Attach hardware

H95581

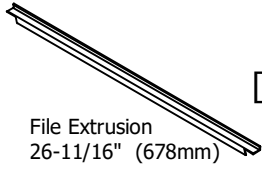

[2]

H89793

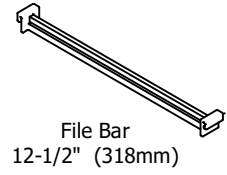

[4]

H94928

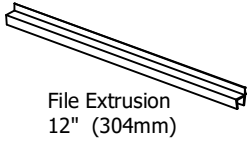

[4]

2x

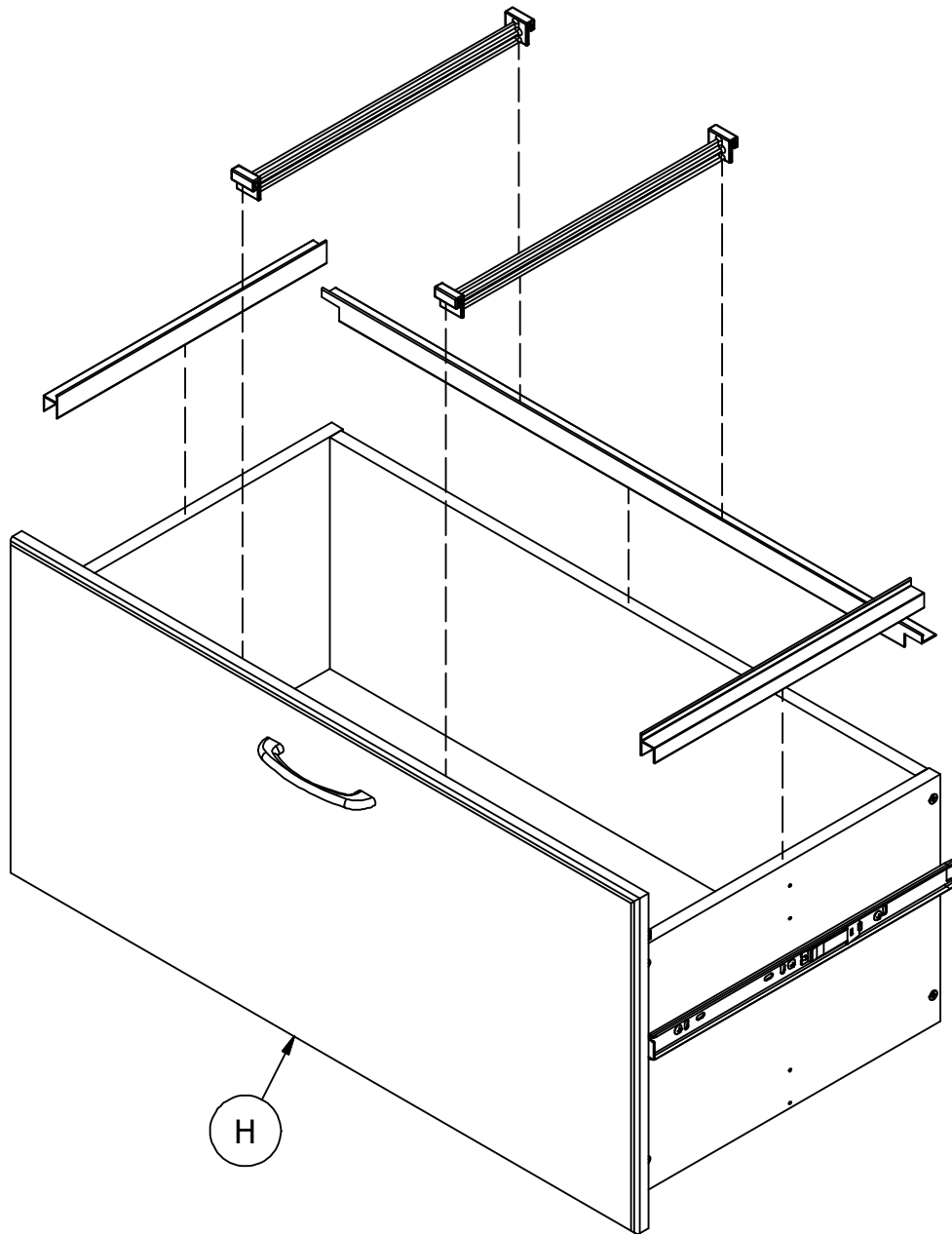

STEP 8

Prepare Panel

Scan QR Code to Watch Video on:



How to Separate and Install Drawer Slides

H195734  [6]
M6.3 X 13MM

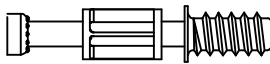
H72988  [3]
KD Bolt

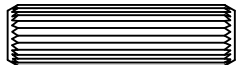
H38169  [2]
Wood Dowel 8 x 30

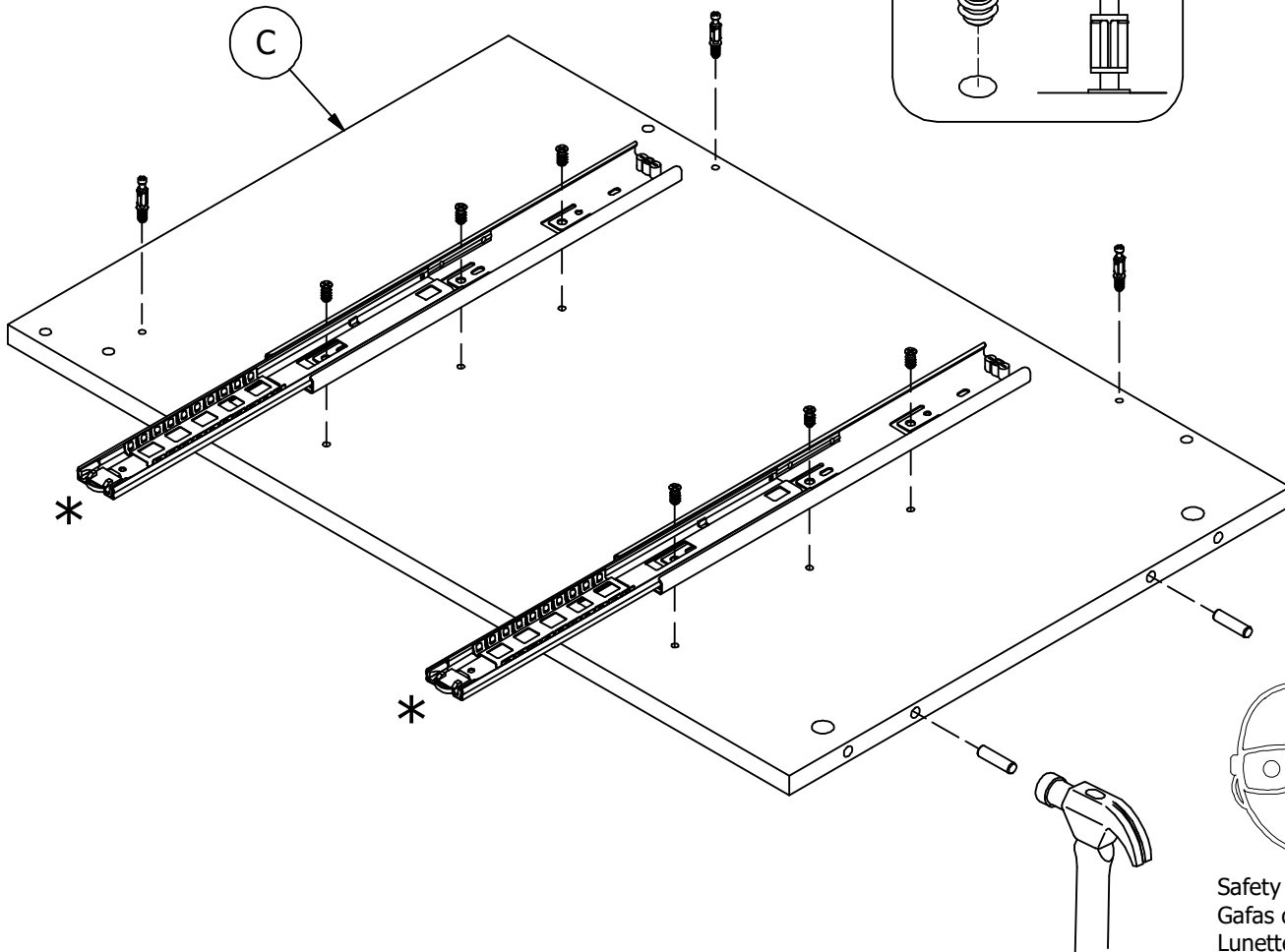
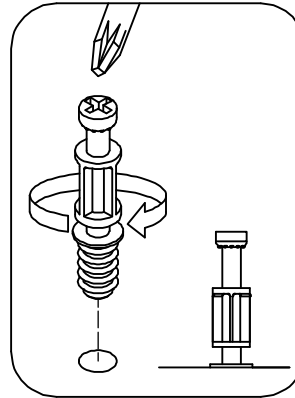
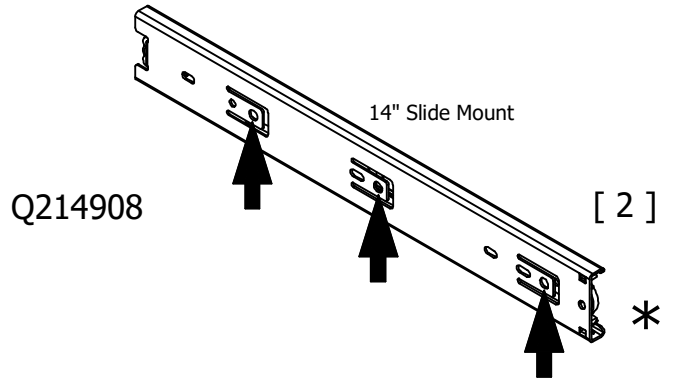

Safety glasses
Gafas de seguridad
Lunettes de protection

STEP 9

Prepare Panel

Scan QR Code to Watch Video on:



How to Separate and Install Drawer Slides

H192100 [2]
#8 x 1/2"

H195734 [6]
M6.3 X 13MM

H38169 [2]
Wood Dowel 8 x 30

H72988 [3]
KD Bolt

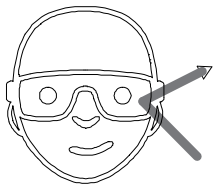
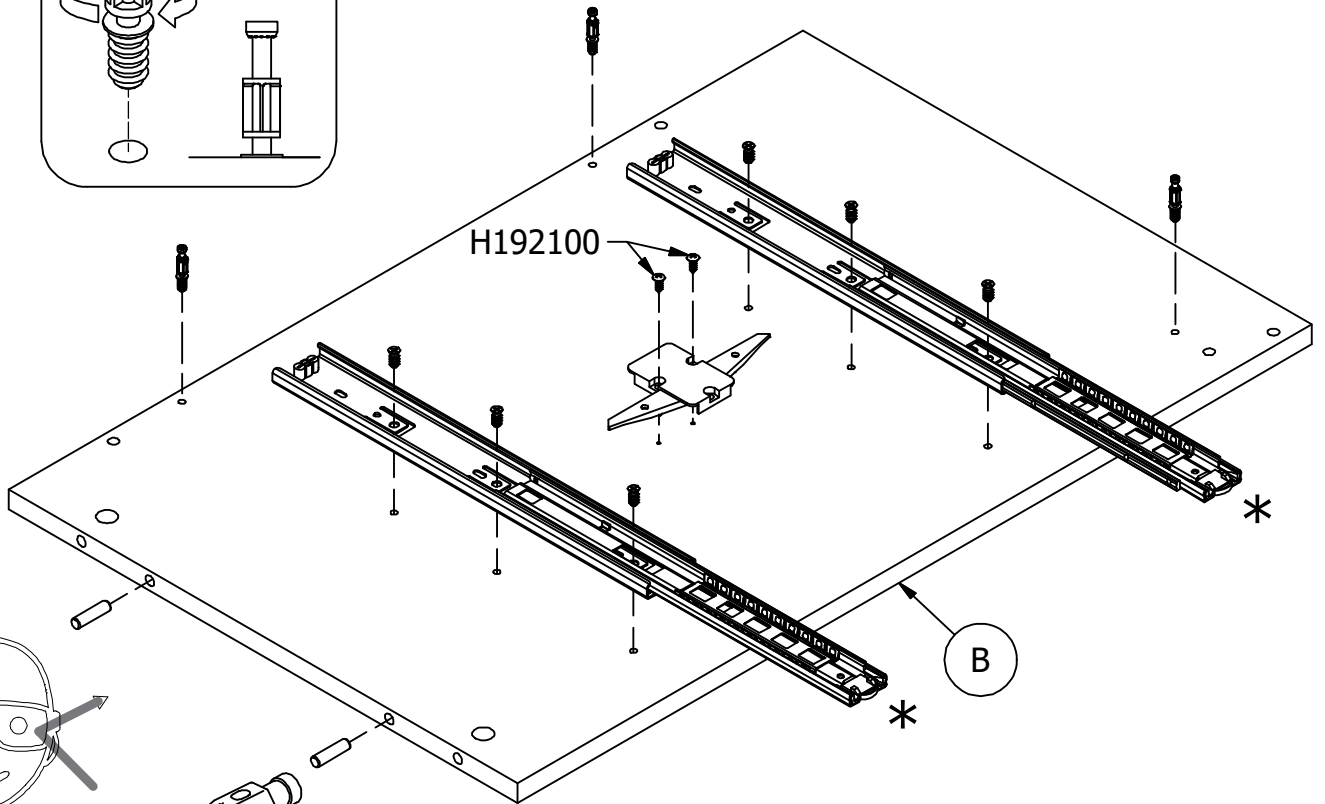
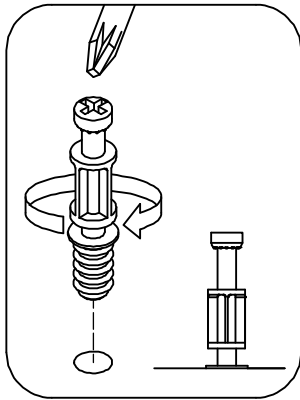
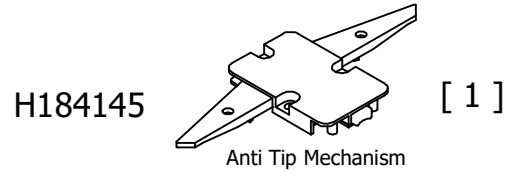
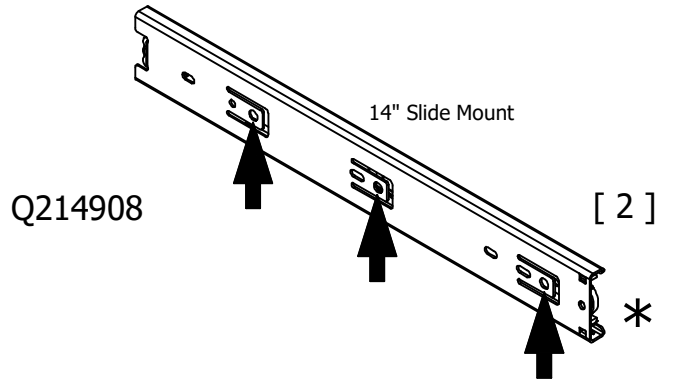

Safety glasses
Gafas de seguridad
Lunettes de protection



STEP 10

Assemble Panels

H150333

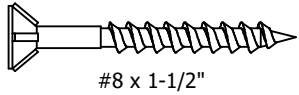

[2]

H38169



[6]

Wood Dowel 8 x 30

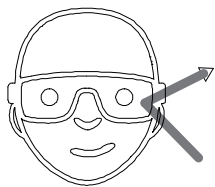
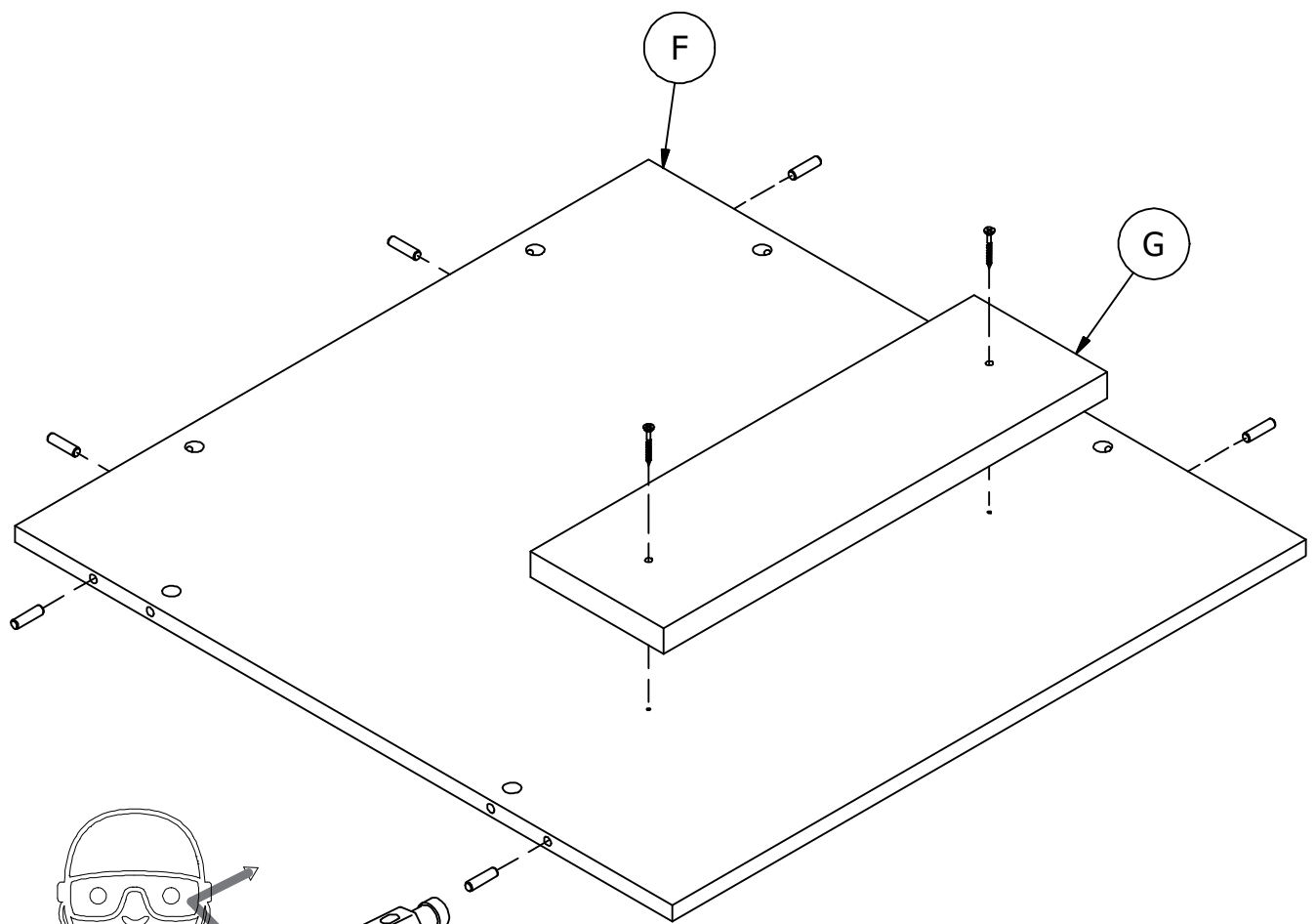

Safety glasses
Gafas de seguridad
Lunettes de protection



STEP 11

Assemble Panels

Scan QR Code to Watch Video on:



How to Tighten KD Cams

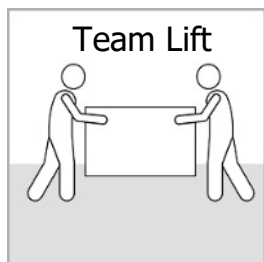

H181468US



[2]

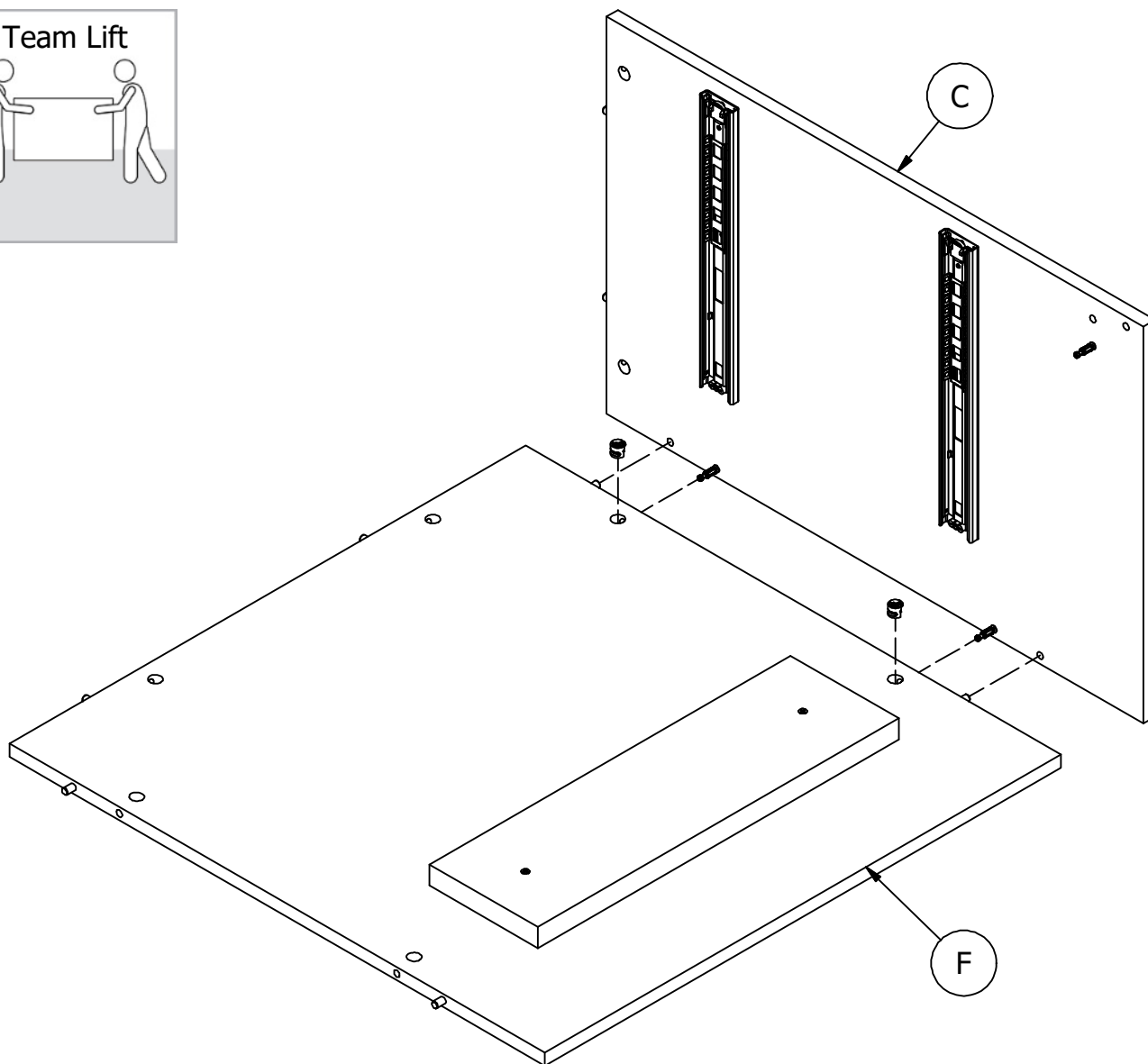
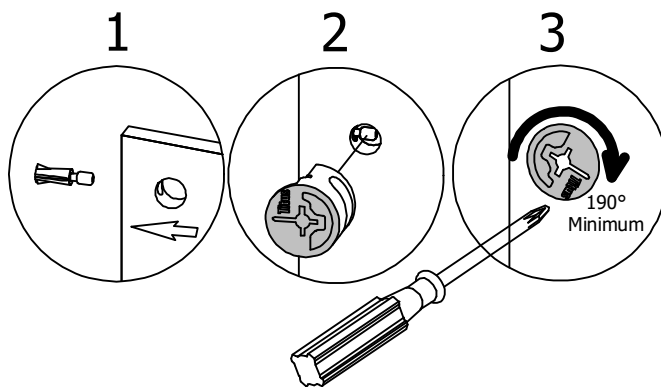

STEP 12

Prepare and Assemble Panels

Scan QR Code to Watch Video on:



How to Tighten KD Cams

H38169  [6]
Wood Dowel 8 x 30

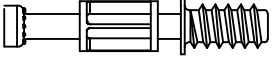
H72988  [1]
KD Bolt

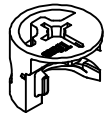
H181468US  [1]
KD Cam3000

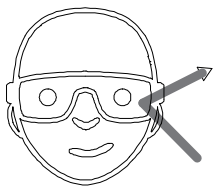
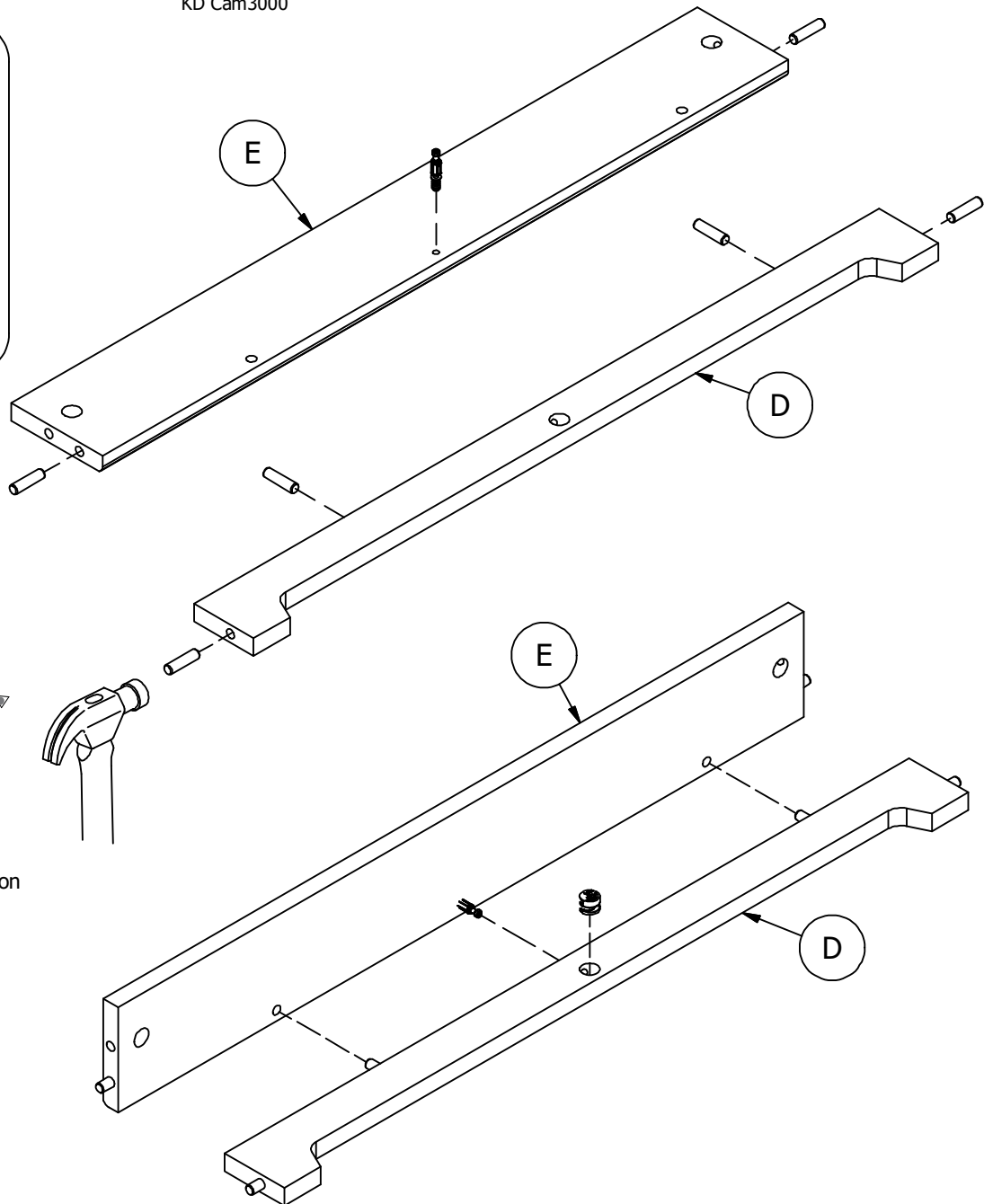
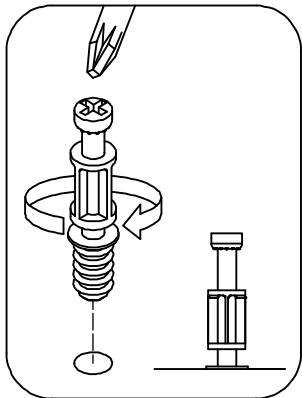
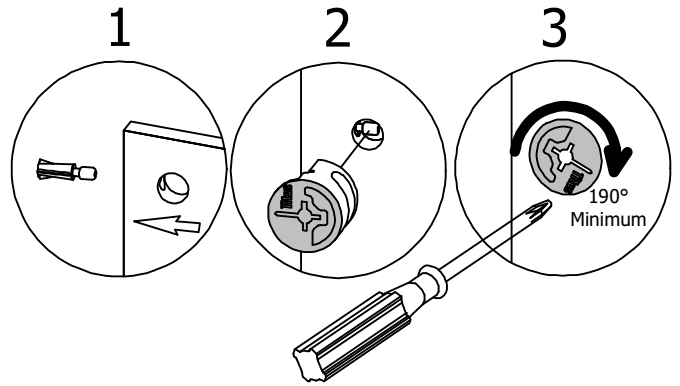

Safety glasses
Gafas de seguridad
Lunettes de protection

STEP 13

Assemble Panels

Scan QR Code to Watch Video on:



How to Tighten KD Cams

H181468US



[1]

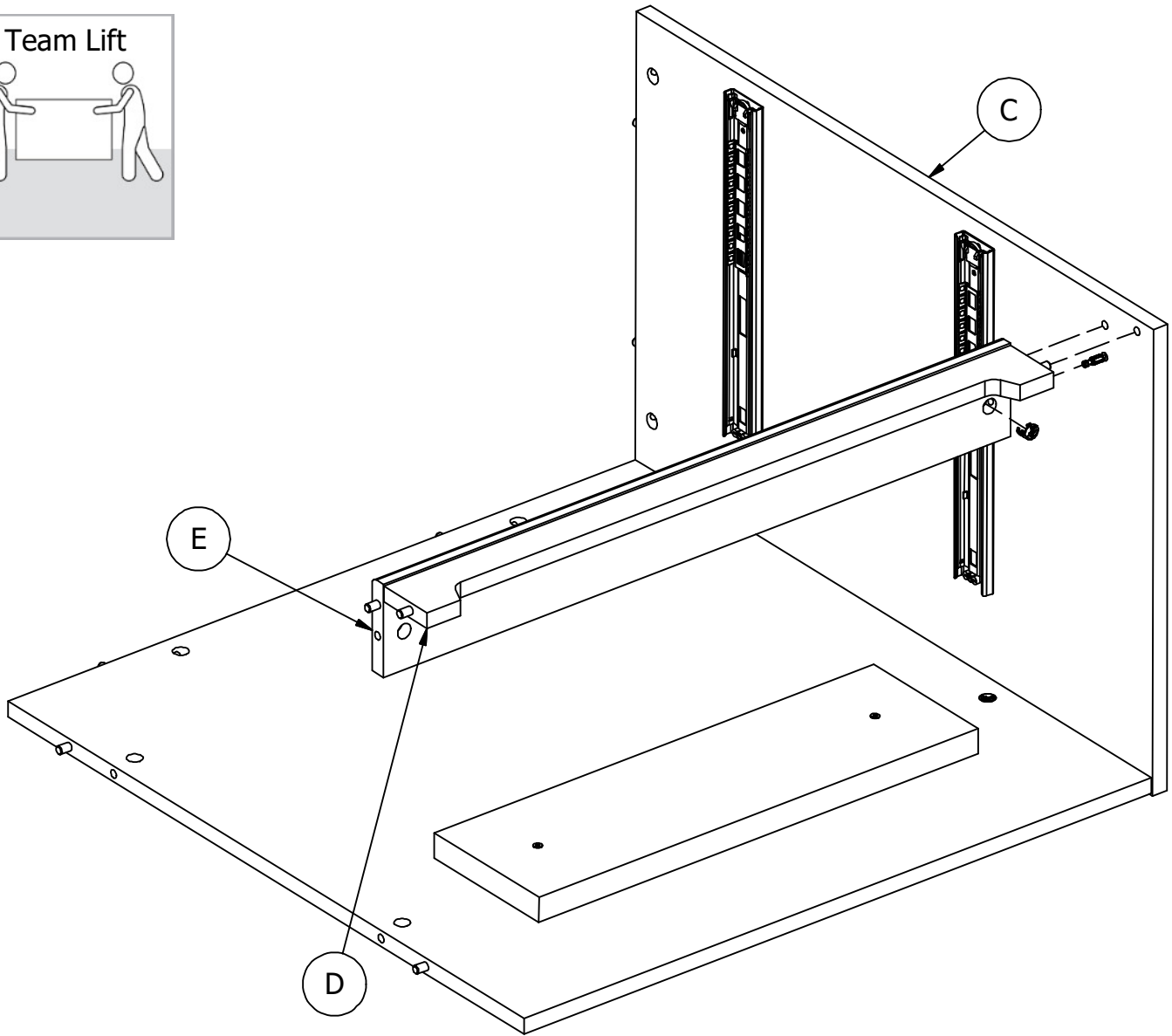
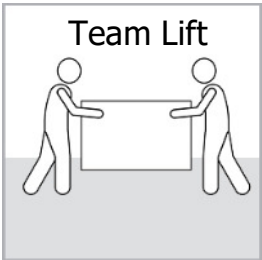
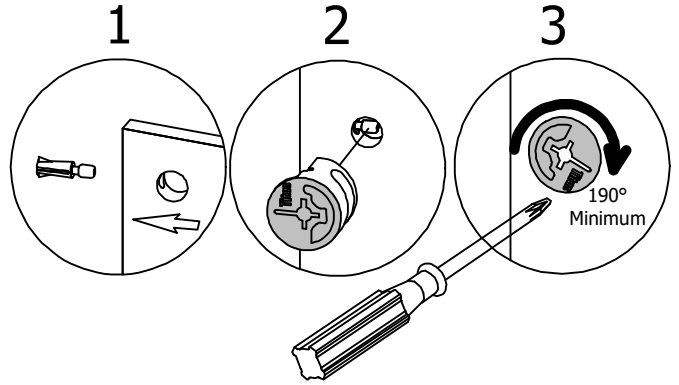

STEP 14

Assemble Panels

Scan QR Code to Watch Video on:



How to Tighten KD Cams

H181468US



[3]

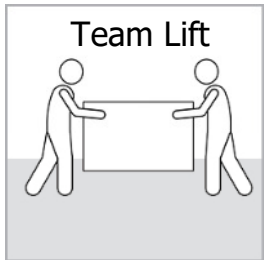
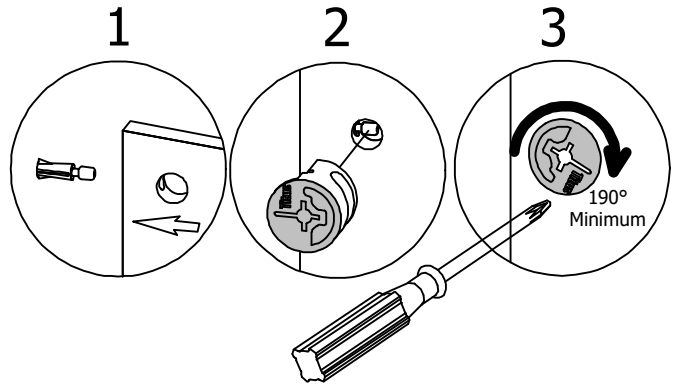

Team Lift

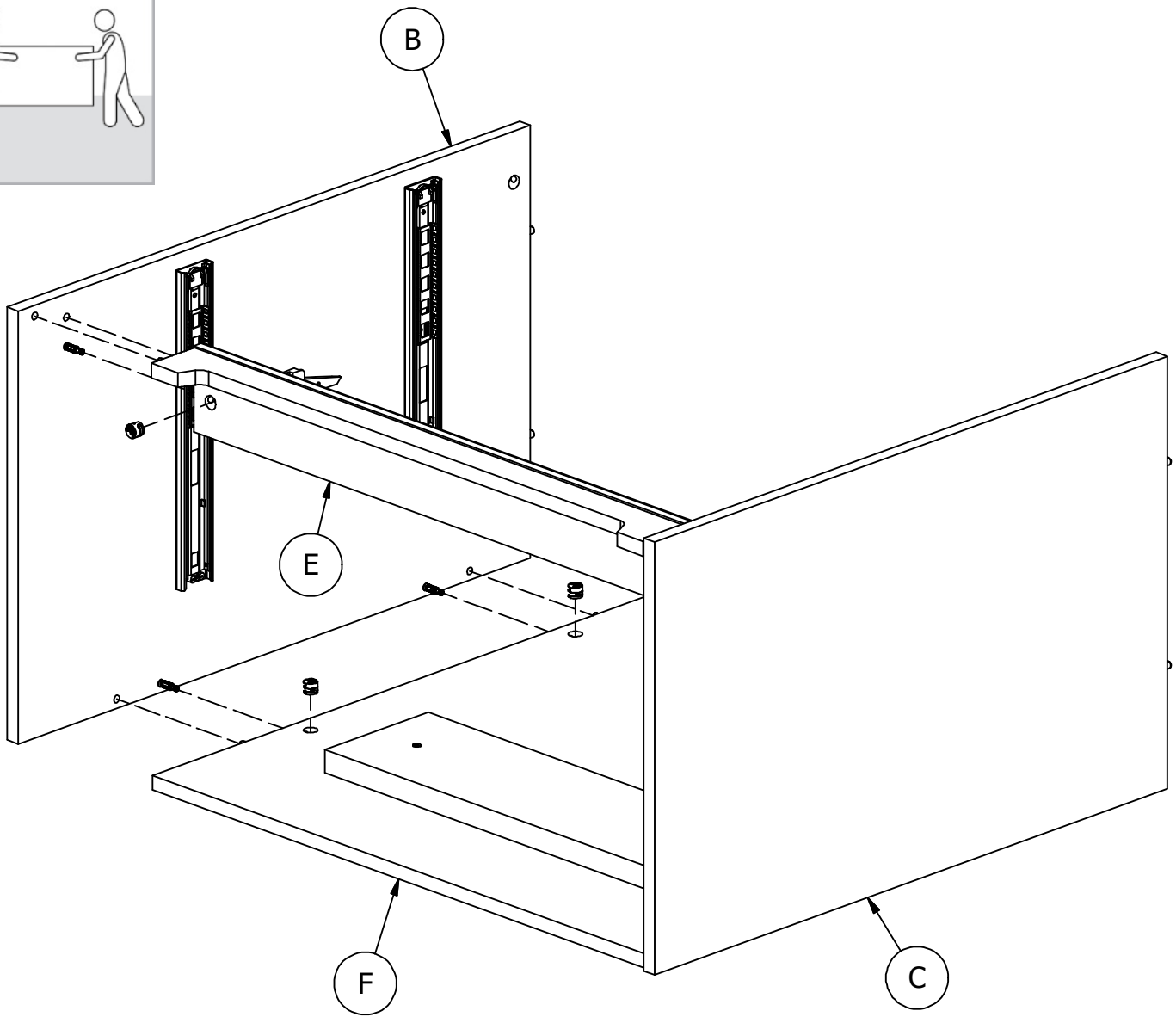

STEP 15

Prepare Panel

H72988 [6]
KD Bolt

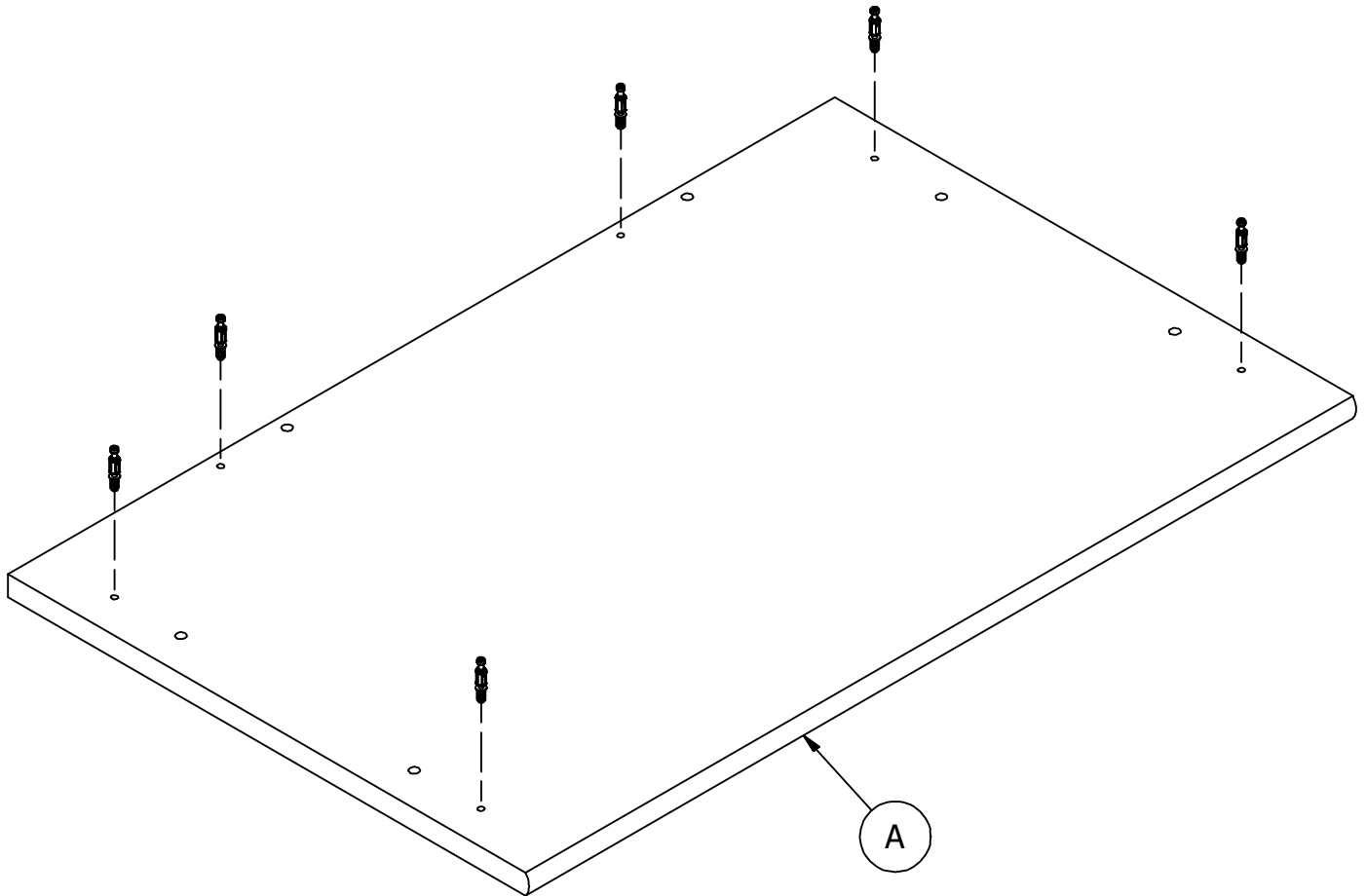
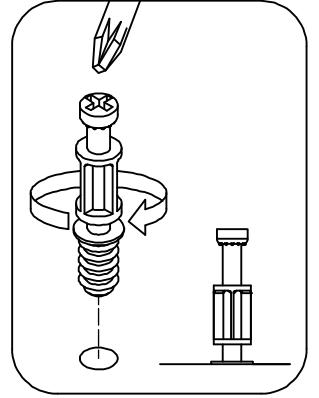

STEP 16

Assemble Panels

Scan QR Code to Watch Video on:



How to Tighten KD Cams

H181468US



[6]

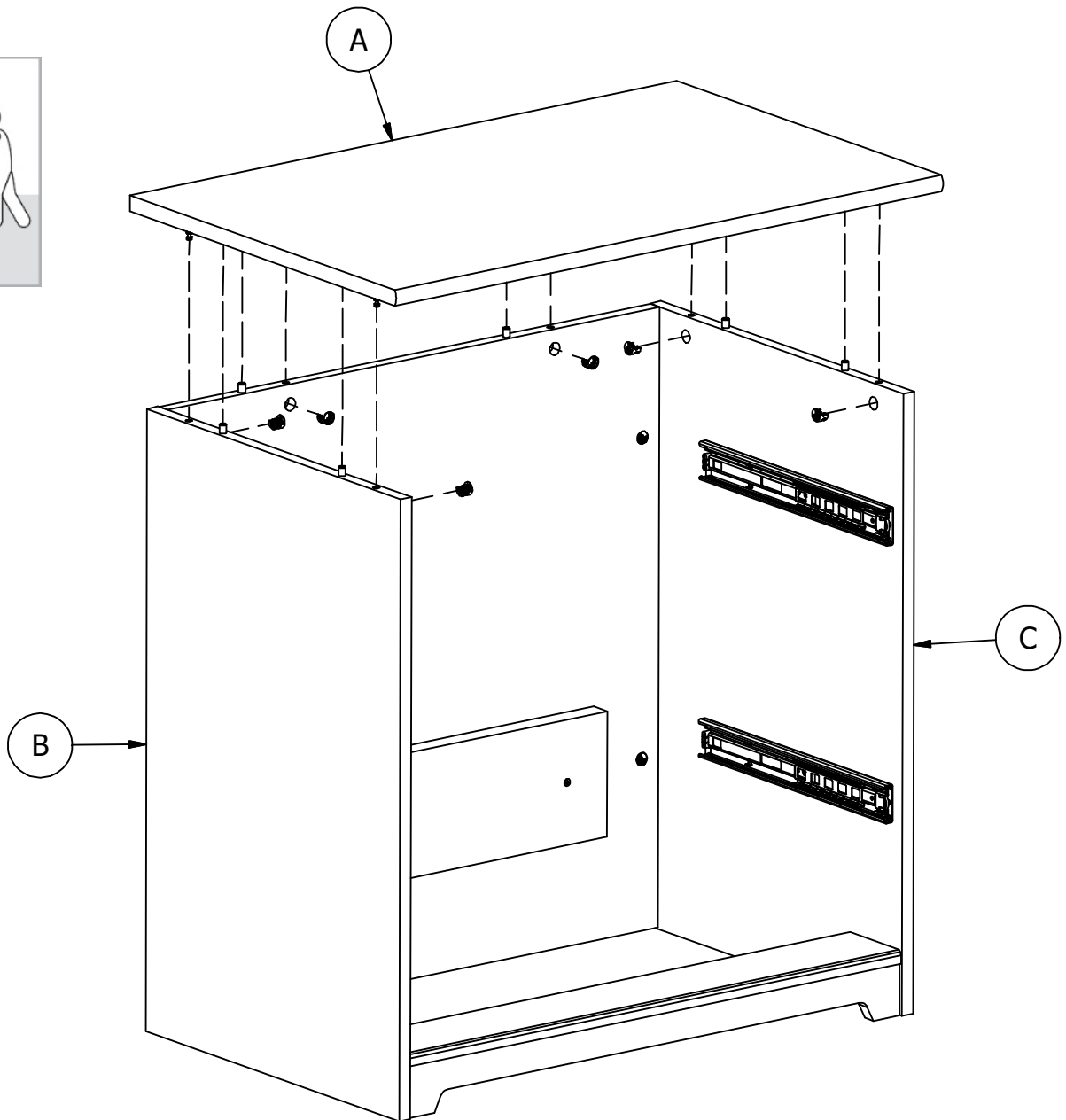
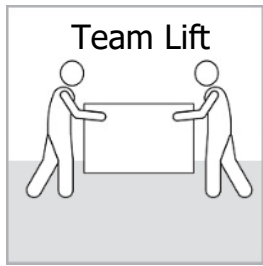
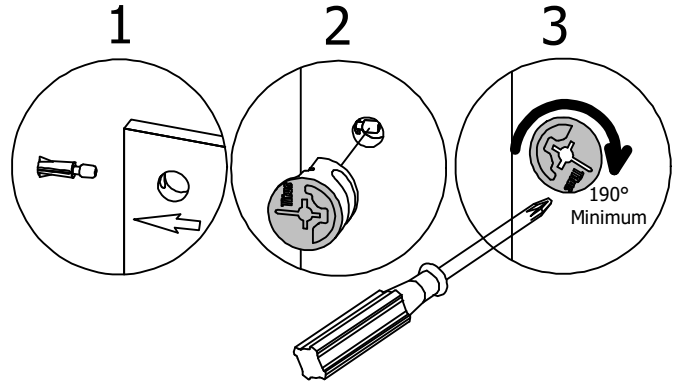

STEP 17

Insert Lower Drawer

Scan QR Code to
Watch Video on:



How to Separate
and Install Drawer
Slides

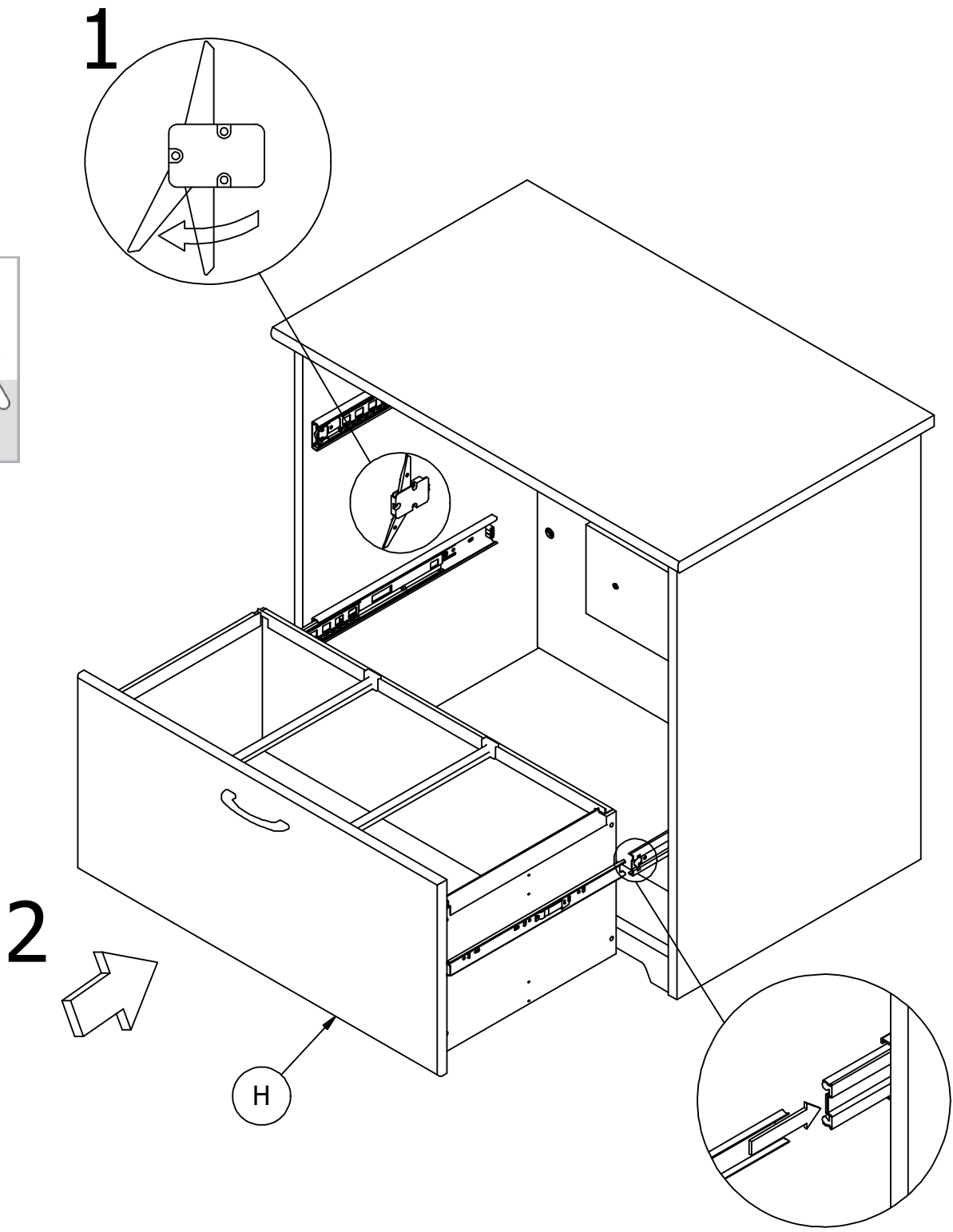
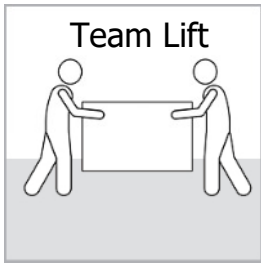

STEP 18

Attach Hardware

H184144 [1]
Anti Tip Wedge

H192100 [2]
#8 x 1/2"

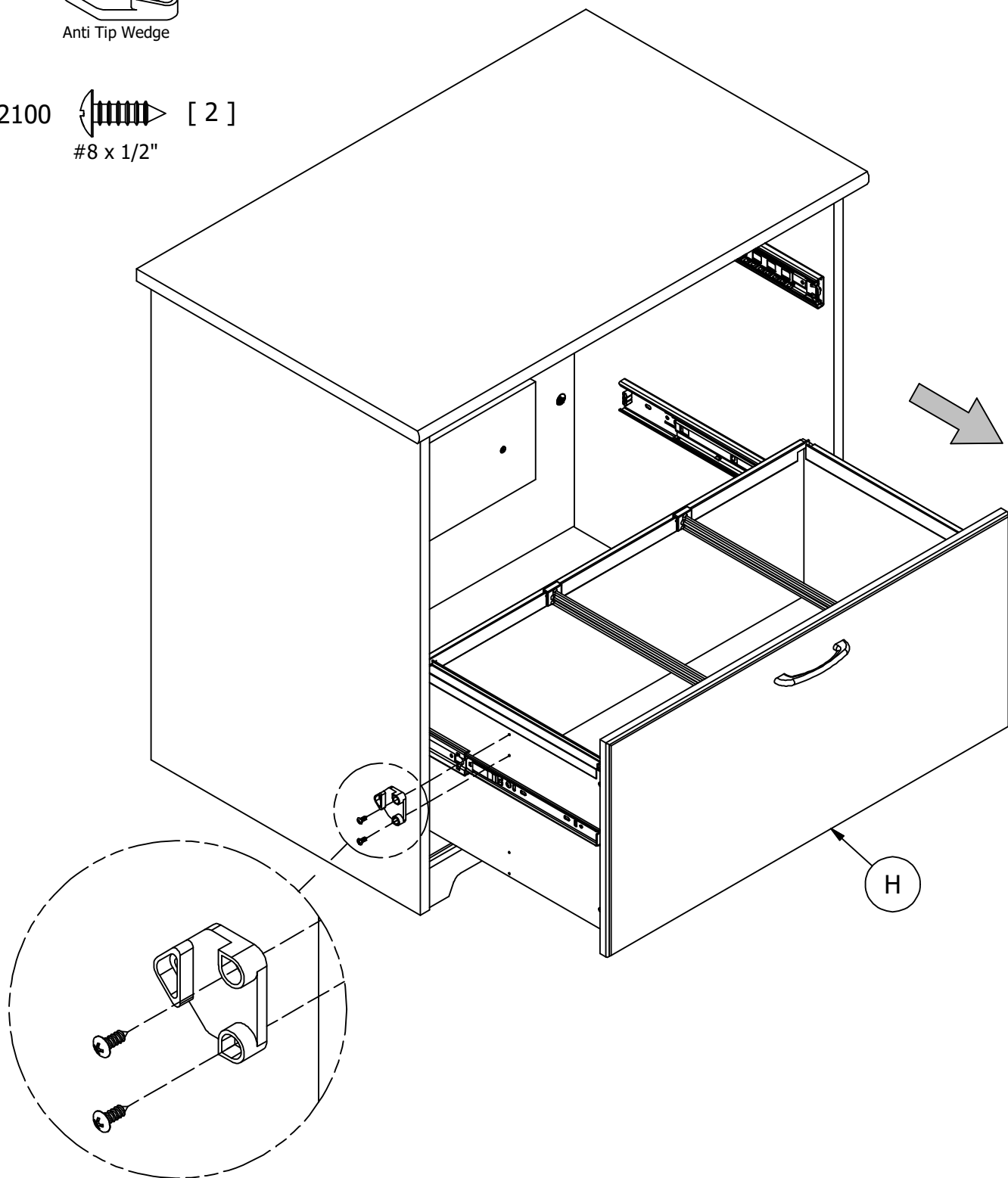

STEP 19

Insert Upper Drawer

Scan QR Code to
Watch Video on:



How to Separate
and Install Drawer
Slides

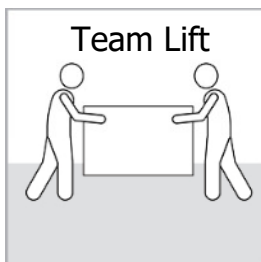

- 1 Close lower drawer
Cerrar cajón inferior
Fermer le tiroir inférieur

- 2

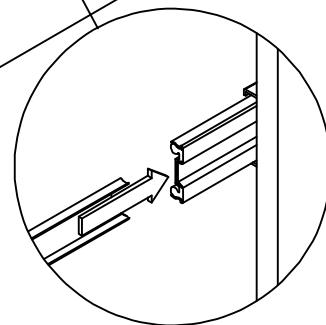
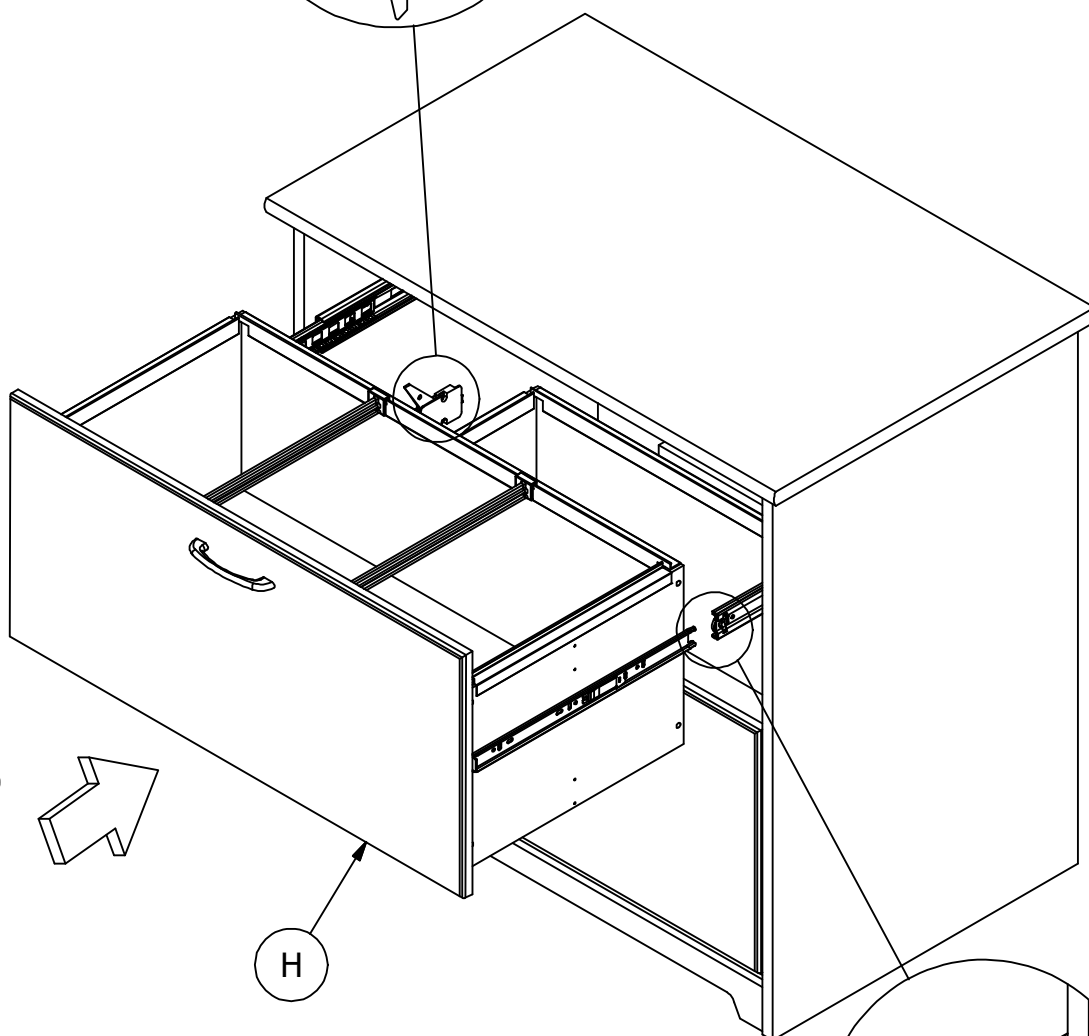
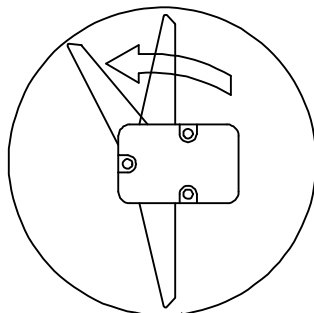

STEP 20

Attach Hardware

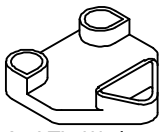
H184144  [1]
Anti Tip Wedge

H192100  [2]
#8 x 1/2"

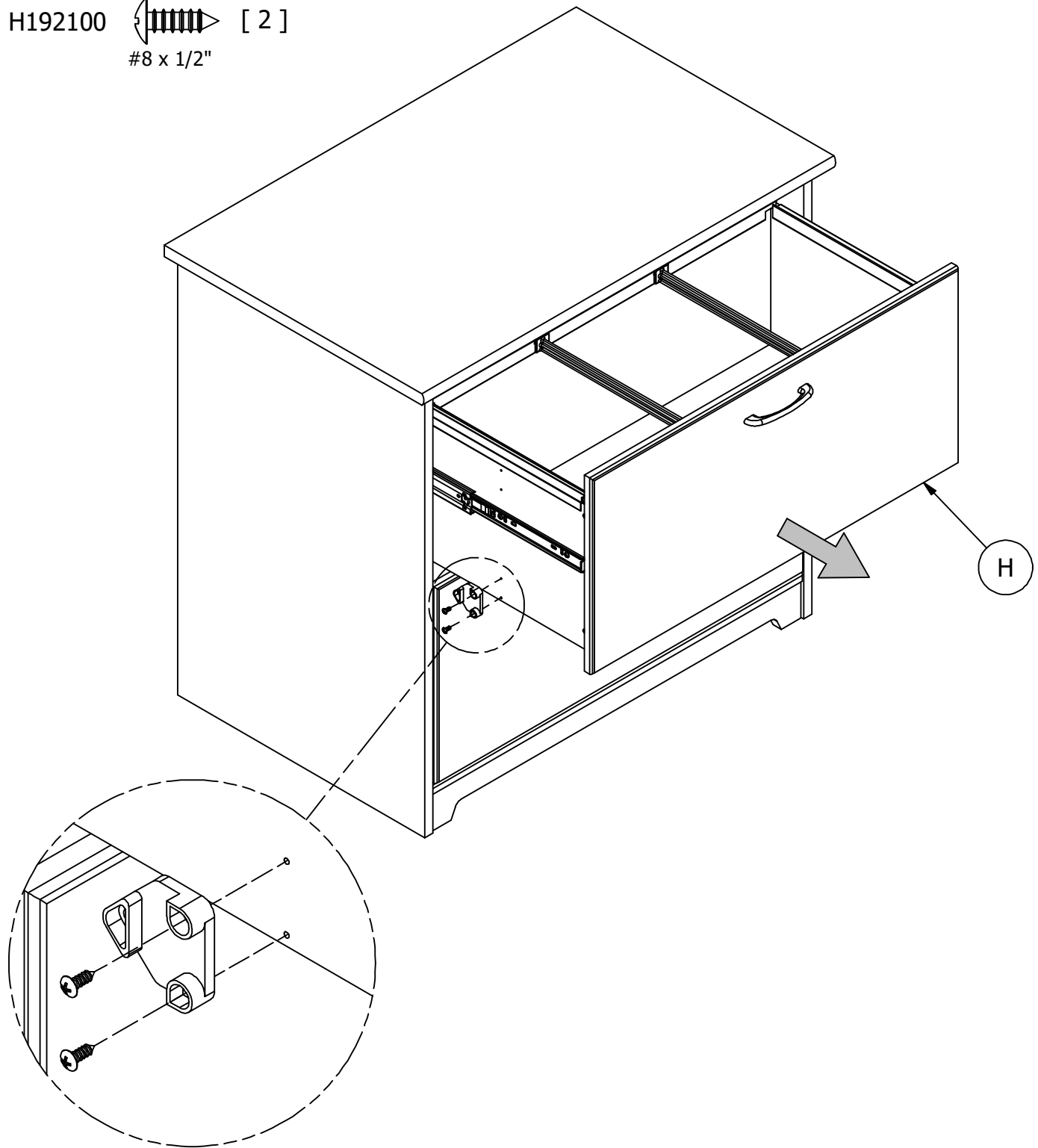

STEP 21

Drawer Adjustment

Scan QR Code to Watch Video on:



How to Adjust Drawer Fronts

DRAWER FRONT VIEW

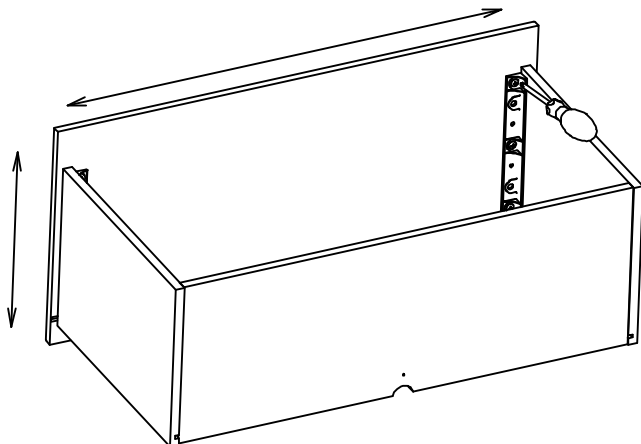
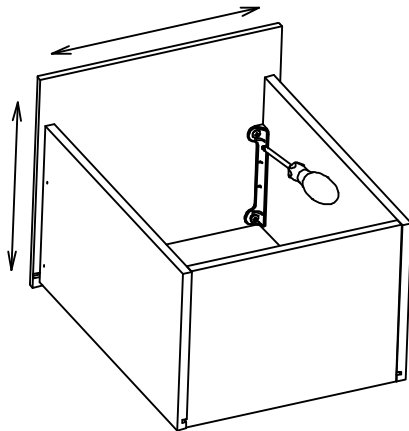
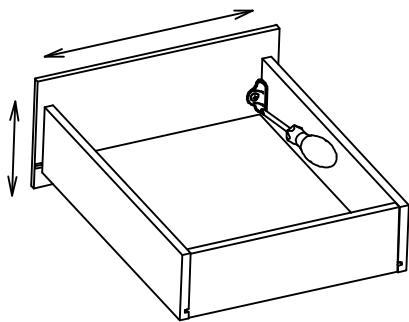
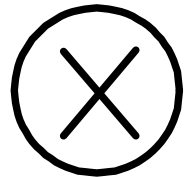
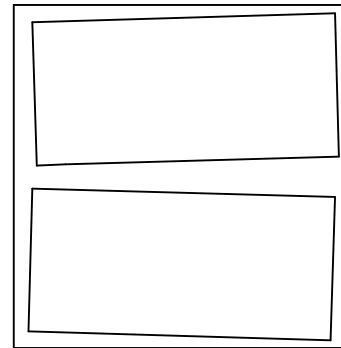
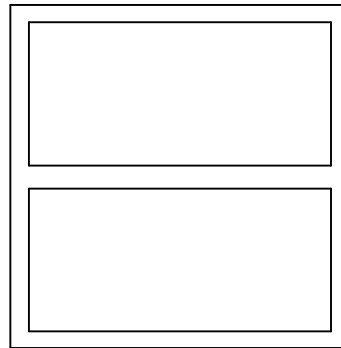

REQUIRED TOOL: PHILLIPS SCREWDRIVER

HERRAMIENTA REQUERIDA: DESTORNILLADOR PHILLIPS
OUTIL REQUIS: TOURNEVIS CRUCIFORME

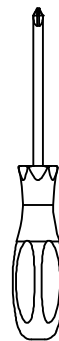

1. LOOSEN SCREWS.
2. ADJUST DRAWER FRONTS.
3. TIGHTEN SCREWS.

1. Afloje los tornillos
2. Ajustar frentes de cajón
3. Apriete los tornillos

1. Desserrer les vis
2. Ajuster les façades des tiroirs
3. Serrer les vis

STEP 22

Cleaning and Maximum Loading

Scan QR Code to
Watch Video on:



How to Clean
the Surface

File drawers hold letter, legal or A4 size files.

Las gavetas para archivador reciben archivos de tamaño carta, legal o A4.

Les tiroirs a dossiers peuvent accueillir des dossiers de format lettre, grand format ou A4.

Gently clean surfaces with a damp sponge eraser.

Maximum Weight: 71 Lbs.
Peso Máximo: 71 Libras
Poids Maximum: 32 kilogramme

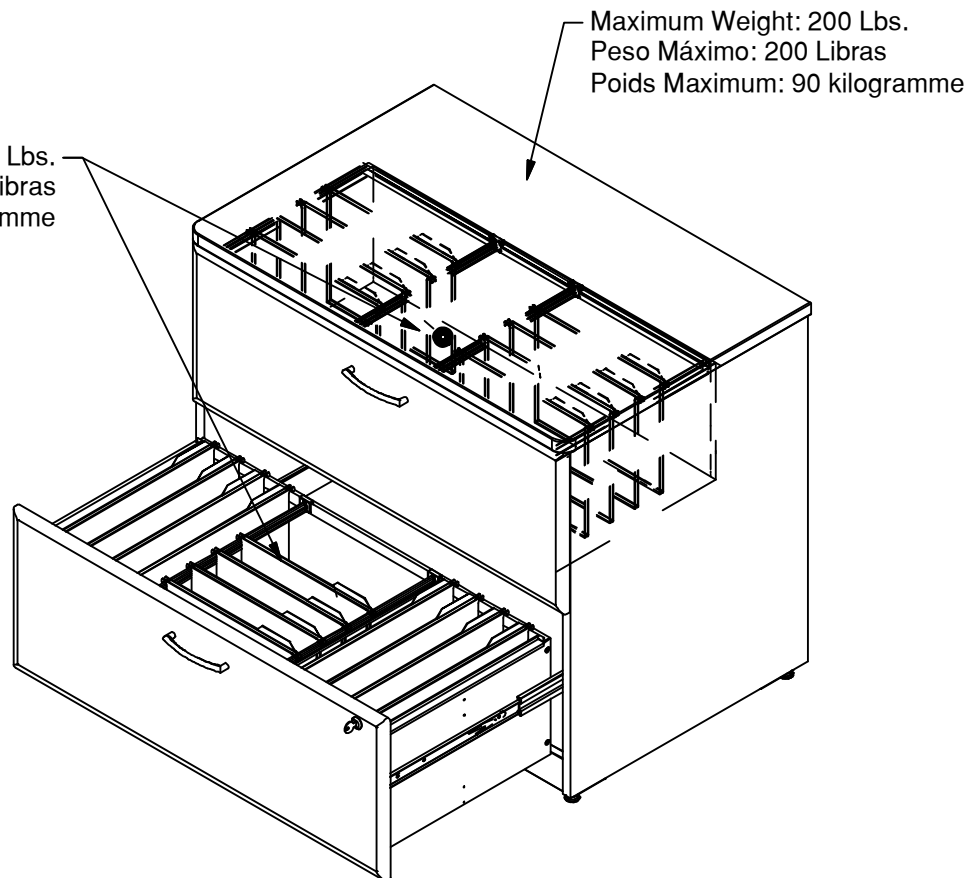

Congratulations! You are all done. If you have any questions or concerns, please call.

PARTS LIST

WC31280

A	[1]	W197071	TOP SHELF
B	[1]	W213413	LEFT SIDE PANEL
C	[1]	W213414	RIGHT SIDE PANEL
D	[1]	W197077	BOTTOM RAIL
E	[1]	W197074	SUPPORT RAIL
F	[1]	W197075	BACK PANEL
G	[1]	W184914	BALLAST
H	[2]	W197076	DRAWER FRONT
I	[4]	W195654	DRAWER SIDE
J	[2]	W195675	DRAWER BACK
K	[2]	W182006	DRAWER BOTTOM

H192372US

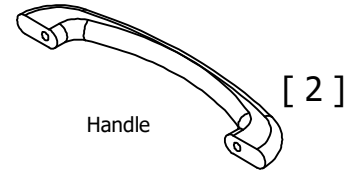

WC31980

A	[1]	W192188	TOP SHELF
B	[1]	W195657	LEFT SIDE PANEL
C	[1]	W195658	RIGHT SIDE PANEL
D	[1]	W193720	BOTTOM RAIL
E	[1]	W192192	SUPPORT RAIL
F	[1]	W192193	BACK PANEL
G	[1]	W184914	BALLAST
H	[2]	W192194	DRAWER FRONT
I	[4]	W195654	DRAWER SIDE
J	[2]	W195675	DRAWER BACK
K	[2]	W182006	DRAWER BOTTOM

H192372US

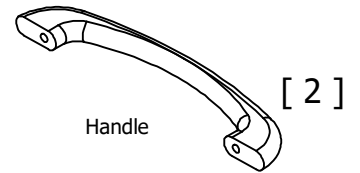

WC31780

A	[1]	W184908	TOP SHELF
B	[1]	W195655	LEFT SIDE PANEL
C	[1]	W195656	RIGHT SIDE PANEL
D	[1]	W193719	BOTTOM RAIL
E	[1]	W184912	SUPPORT RAIL
F	[1]	W184913	BACK PANEL
G	[1]	W184914	BALLAST
H	[2]	W184915	DRAWER FRONT
I	[4]	W195654	DRAWER SIDE
J	[2]	W195675	DRAWER BACK
K	[2]	W182006	DRAWER BOTTOM

H160870US

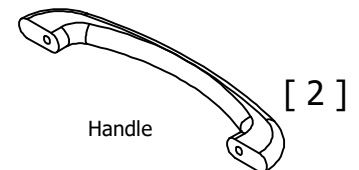

PARTS LIST

WC31480

A	[1]	W210227	TOP SHELF
B	[1]	W210228	LEFT SIDE PANEL
C	[1]	W210229	RIGHT SIDE PANEL
D	[1]	W210230	BOTTOM RAIL
E	[1]	W210231	SUPPORT RAIL
F	[1]	W210232	BACK PANEL
G	[1]	W184914	BALLAST
H	[2]	W210233	DRAWER FRONT
I	[4]	W195654	DRAWER SIDE
J	[2]	W195675	DRAWER BACK
K	[2]	W182006	DRAWER BOTTOM

H160870US

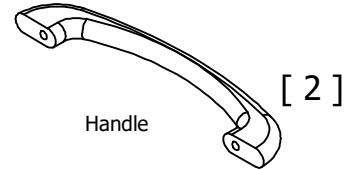

WC31880

A	[1]	W213270	TOP SHELF
B	[1]	W213271	LEFT SIDE PANEL
C	[1]	W213272	RIGHT SIDE PANEL
D	[1]	W213273	BOTTOM RAIL
E	[1]	W213274	SUPPORT RAIL
F	[1]	W213275	BACK PANEL
G	[1]	W184914	BALLAST
H	[2]	W213276	DRAWER FRONT
I	[4]	W195654	DRAWER SIDE
J	[2]	W195675	DRAWER BACK
K	[2]	W182006	DRAWER BOTTOM

H160870US

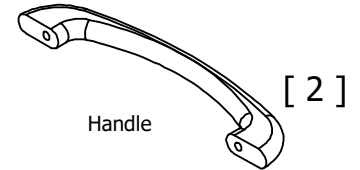

PARTS LIST

WC31380			
LABEL CODE	PART NUMBER	QTY	DESCRIPTION
A	W214204	1	TOP SHELF
B	W214205	1	LEFT SIDE PANEL
C	W214206	1	RIGHT SIDE PANEL
D	W214207	1	BOTTOM RAIL
E	W214208	1	SUPPORT RAIL
F	W214209	1	BACK PANEL
G	W184914	1	BALLAST
H	W214210	2	DRAWER FRONT
I	W195654	4	FILE DRAWER SIDE
J	W195675	2	DRAWER BACK
K	W182006	2	DRAWER BOTTOM

H160870US

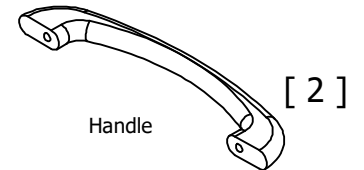

WC31080			
LABEL CODE	PART NUMBER	QTY	DESCRIPTION
A	W214225	1	TOP SHELF
B	W214226	1	LEFT SIDE PANEL
C	W214227	1	RIGHT SIDE PANEL
D	W214228	1	BOTTOM RAIL
E	W214229	1	SUPPORT RAIL
F	W214230	1	BACK PANEL
G	W184914	1	BALLAST
H	W214231	2	DRAWER FRONT
I	W195654	4	FILE DRAWER SIDE
J	W195675	2	DRAWER BACK
K	W182006	2	DRAWER BOTTOM

H200221US

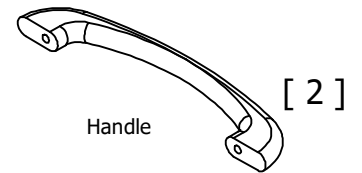

PARTS LIST

WC31180			
LABEL CODE	PART NUMBER	QTY	DESCRIPTION
A	W214218	1	TOP SHELF
B	W214219	1	LEFT SIDE PANEL
C	W214220	1	RIGHT SIDE PANEL
D	W214221	1	BOTTOM RAIL
E	W214222	1	SUPPORT RAIL
F	W214223	1	BACK PANEL
G	W184914	1	BALLAST
H	W214224	2	DRAWER FRONT
I	W195654	4	FILE DRAWER SIDE
J	W195675	2	DRAWER BACK
K	W182006	2	DRAWER BOTTOM

H192372US

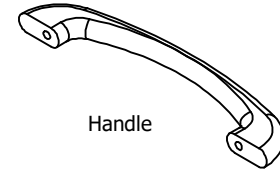

[2]

WC31580			
LABEL CODE	PART NUMBER	QTY	DESCRIPTION
A	W214211	1	TOP SHELF
B	W214212	1	LEFT SIDE PANEL
C	W214213	1	RIGHT SIDE PANEL
D	W214214	1	BOTTOM RAIL
E	W214215	1	SUPPORT RAIL
F	W214216	1	BACK PANEL
G	W184914	1	BALLAST
H	W214217	2	DRAWER FRONT
I	W195654	4	FILE DRAWER SIDE
J	W195675	2	DRAWER BACK
K	W182006	2	DRAWER BOTTOM

H200221US

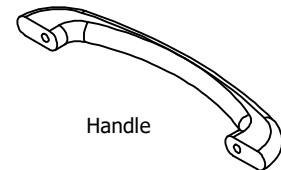

[2]

Maintenance

Maintenance Tip

It may be necessary to periodically open each drawer to its full extension. This will reset the drawer slides and allow for continued smooth operation.

Información de Mantenimiento

Puede ser necesario el abrir cada gaveta a su máxima extensión periódicamente. Este procedimiento ayuda a recomponer las correderas de las gavetas, asegurando una operación libre.

Conseil d'entretien

Il faut de temps en temps ouvrir chaque tiroir jusqu'au bout. Cela remboite les coulisses des tiroirs pour qu'elles continuent de fonctionner sans accroc.

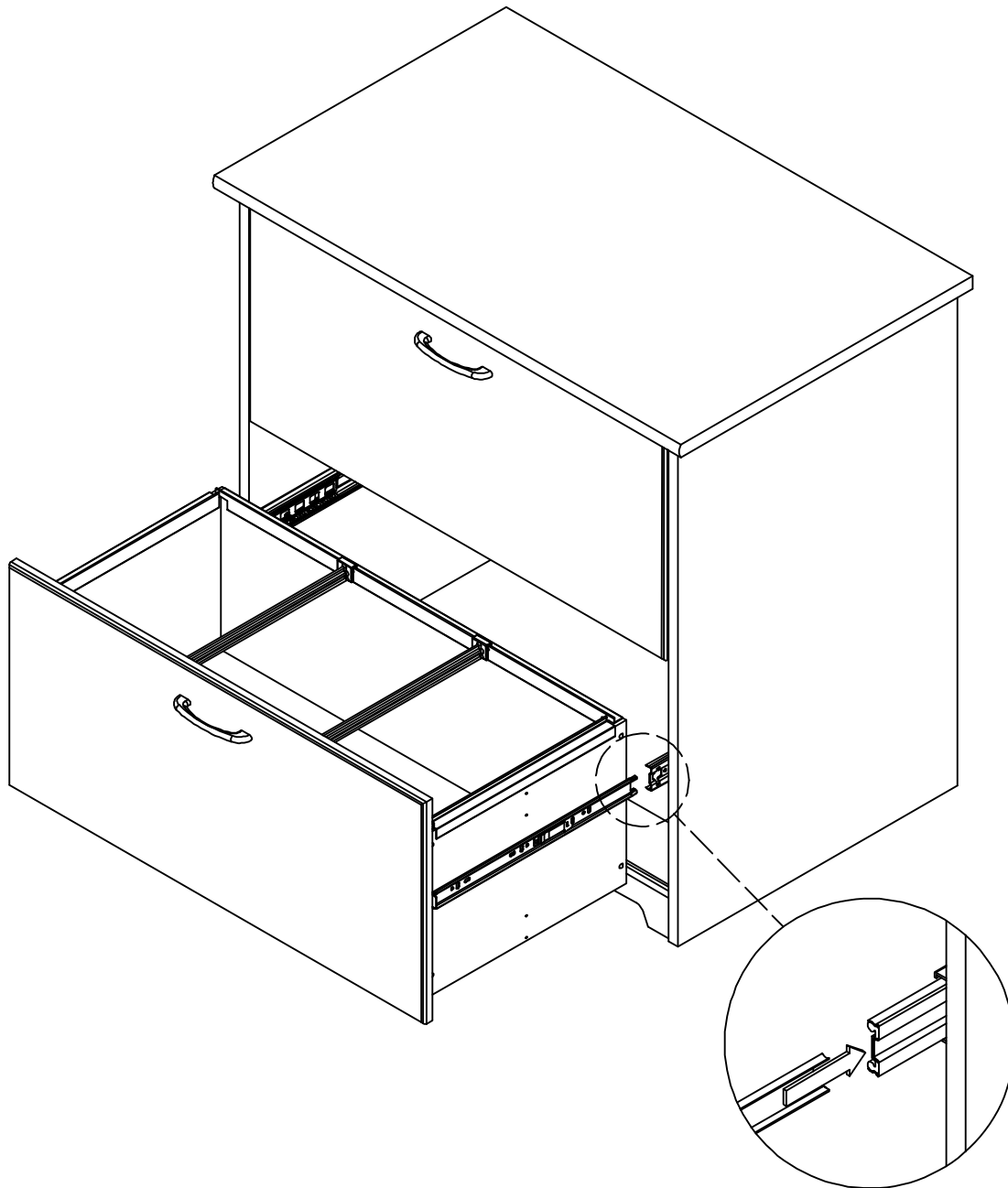

Drawer Removal

Scan QR Code to
Watch Video on:



How to Separate
and Install Drawer
Slides

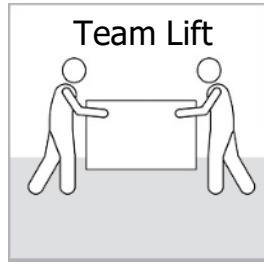

Drawer Removal (if required)
Quitado de Gaveta (si es necesario)
retrait du tiroir (si necessaire)

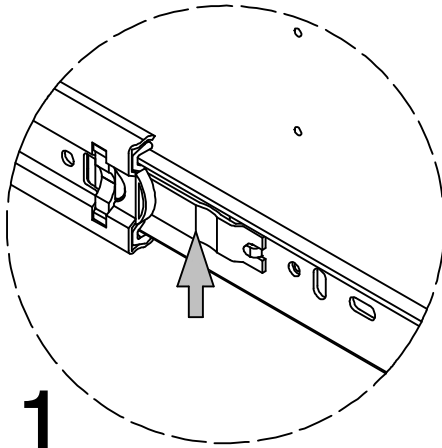

1

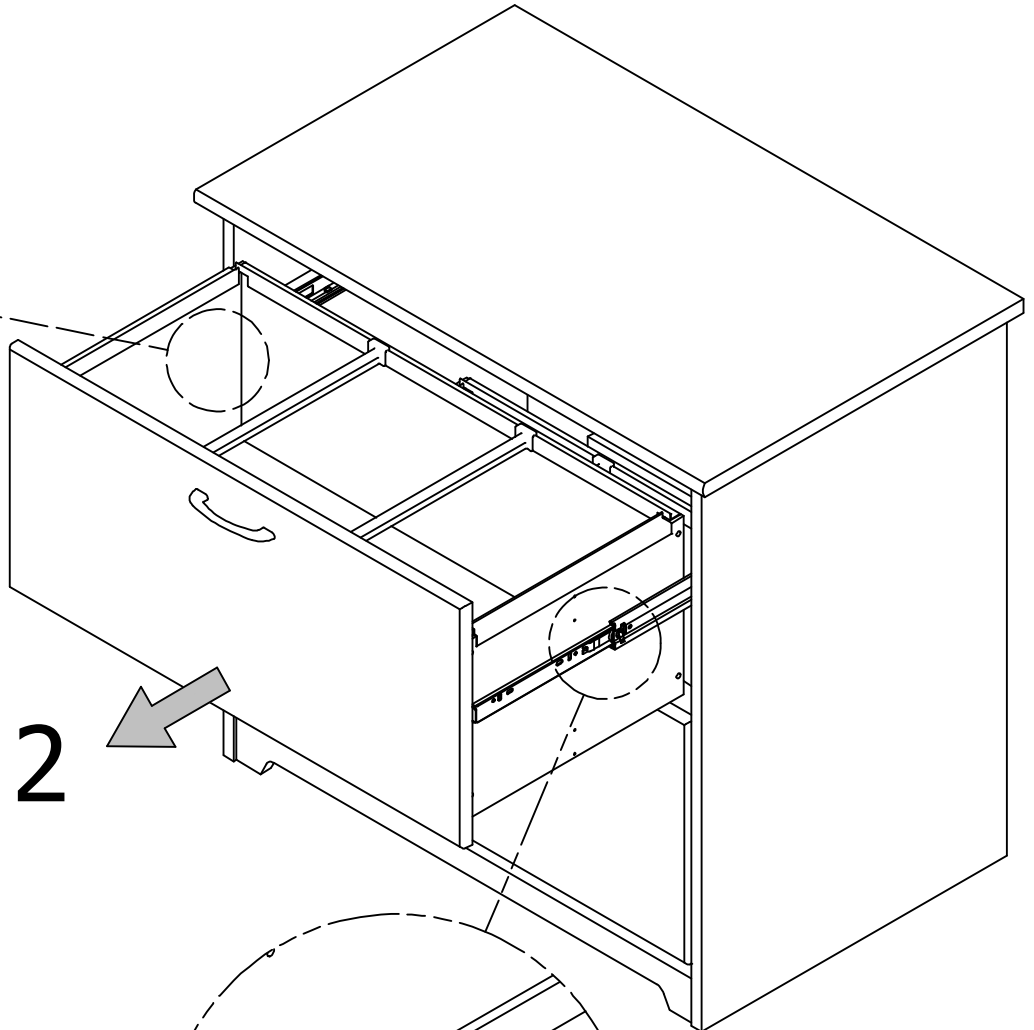

2

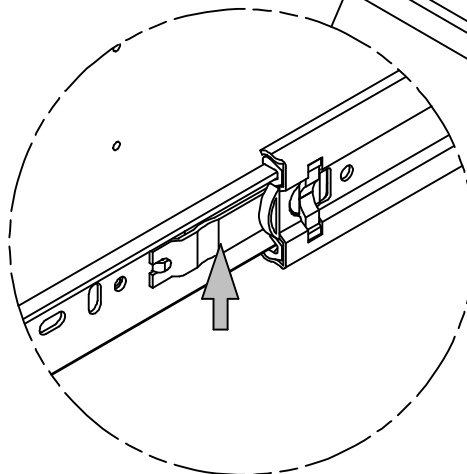

1

Drawer Removal

Scan QR Code to
Watch Video on:



How to Separate
and Install Drawer
Slides

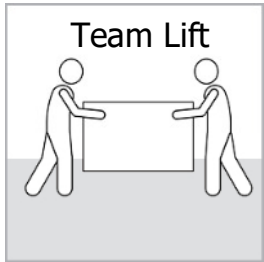

Drawer Removal (if required)
Quitado de Gaveta (si es necesario)
retrait du tiroir (si necessaire)

