

Kitchen Cart



IMPORTANT

Carefully remove all the parts from the carton and place them individually on a soft cloth to prevent scratches or other damage.

Carefully and strictly follow these assembly instructions to ensure a completed product as designed.

Do not use power tools above 8 volts to assemble.

Part List

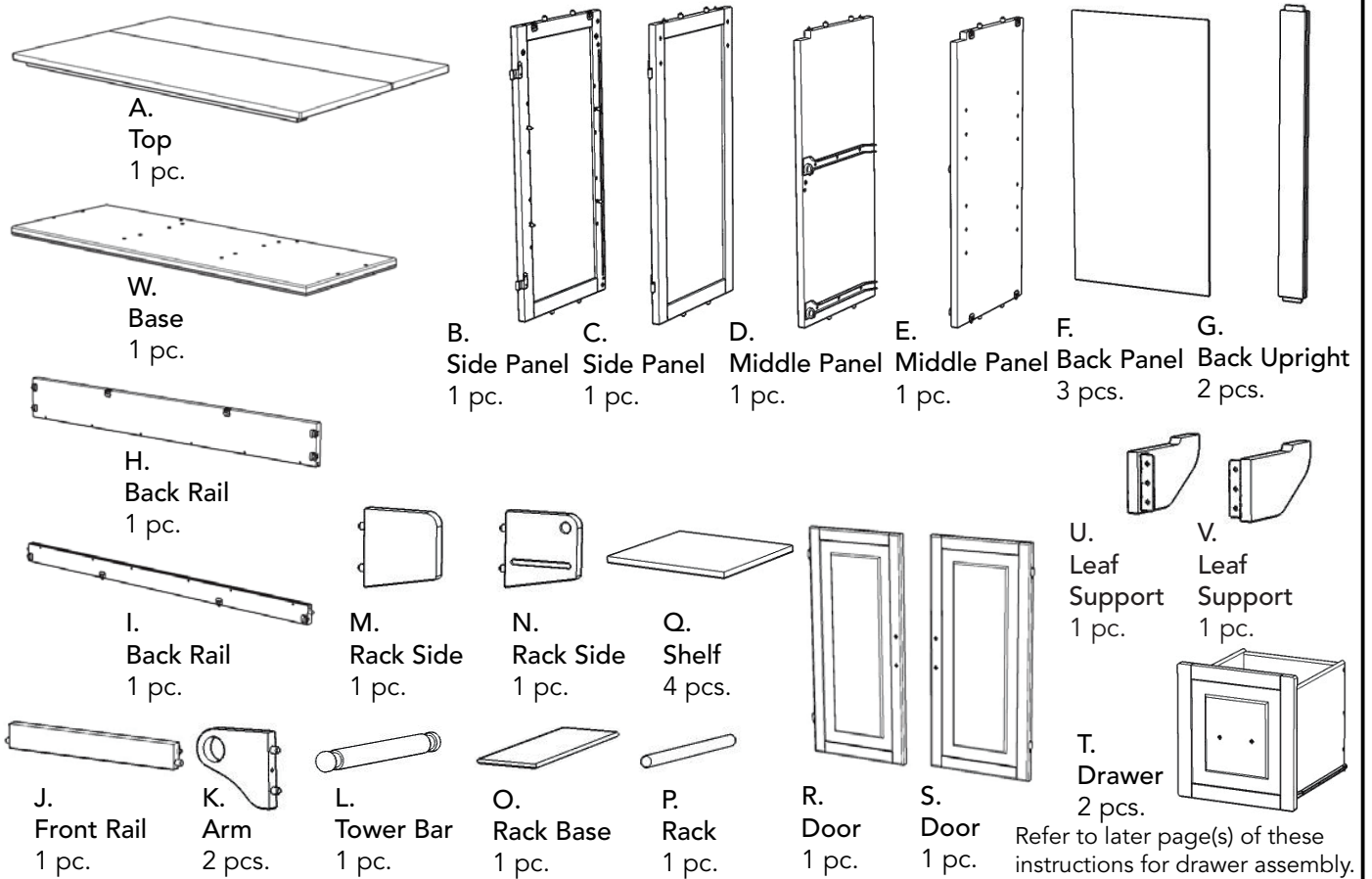

Hardware List

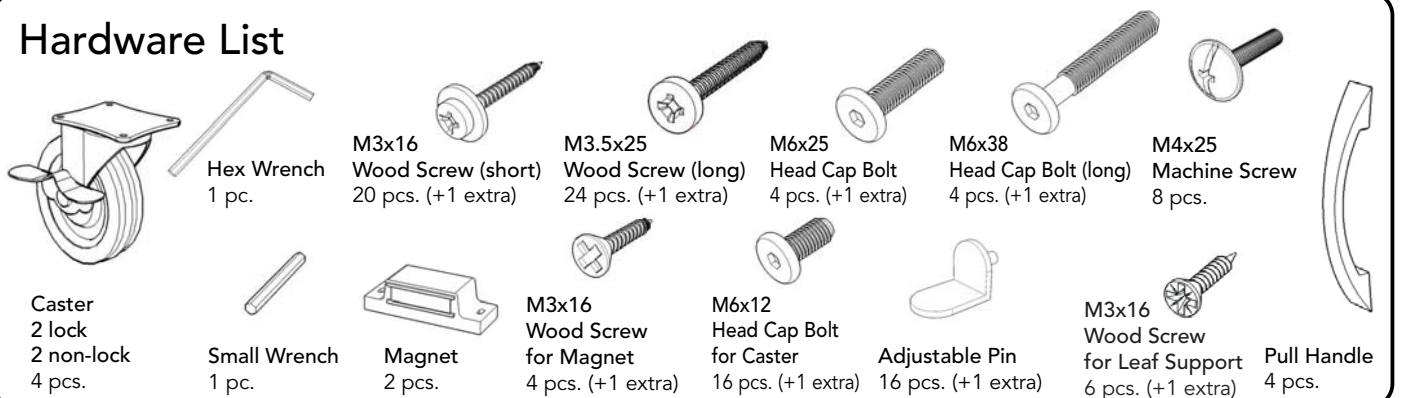

Tool(s) required for assembly: Phillips screwdriver

Assembly Instructions 2/7

IMPORTANT

- Use a soft cloth between these parts and the floor.
- Do not use power tools above 8 volts to assemble.
- Do not tighten all the bolts until each part is properly assembled.
- Keep Hex Wrench as the bolts may need to be tightened in the future.

STEP 1

Assemble Rack Sides (M), (N), Rack Base (O) and Rack (P).

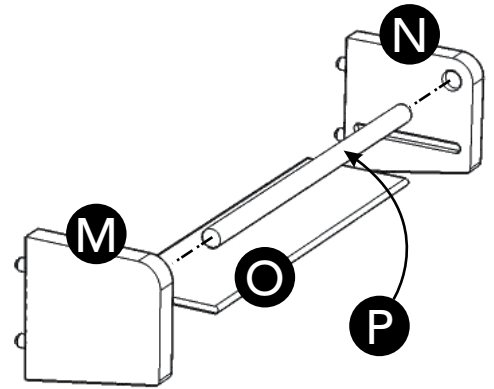

STEP 2

Attach unit to Side Panel (C) with Head Cap Bolts.

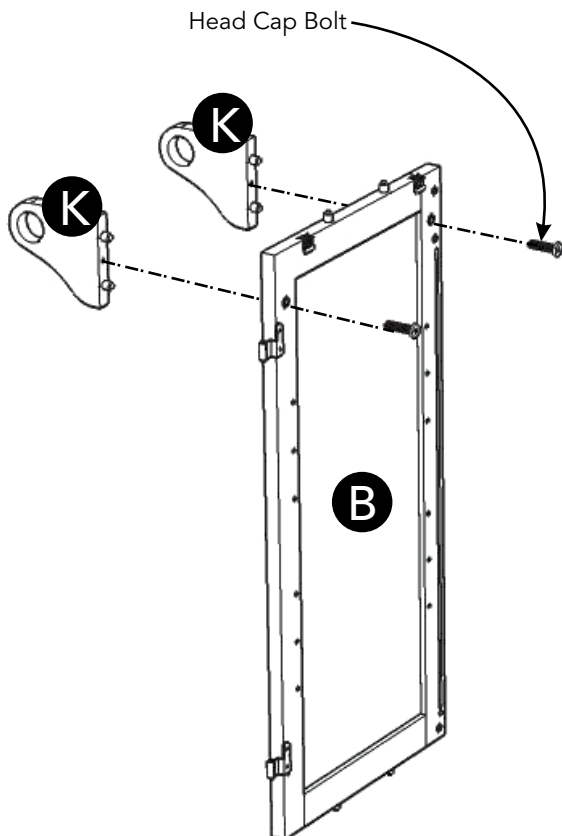
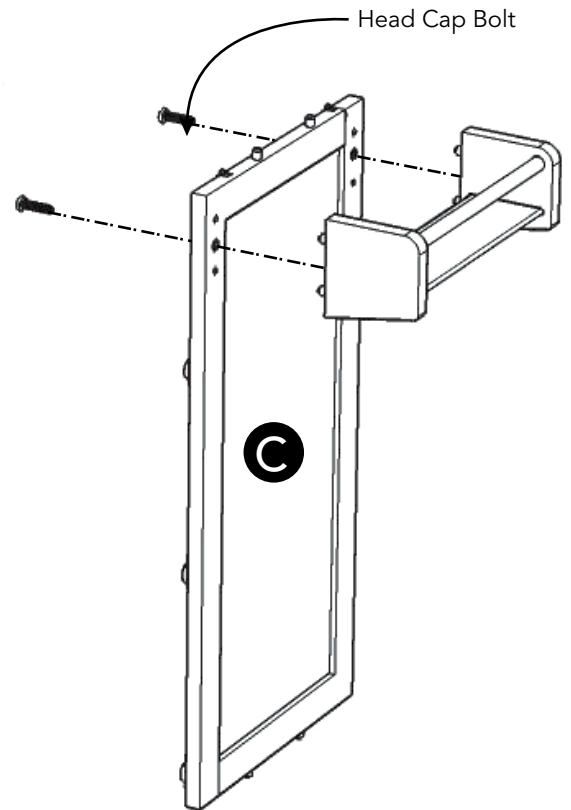

STEP 3

Attach Arms (K) to Side Panel (B) with Head Cap Bolts.

Assembly Instructions 3/7

STEP 4

Attach Back Rail (H) to Side Panel (C), then flip the Locks. (See Figures 1 and 2)

Attach Back Uprights (G) and slide Back Panels (F) into position.

Attach Back Rail (I) to unit, then flip the Lock.

Attach Side Panel (B) to unit, then flip the Locks.

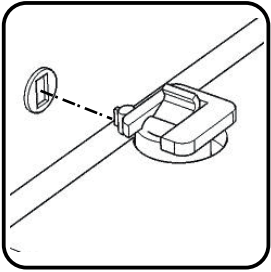
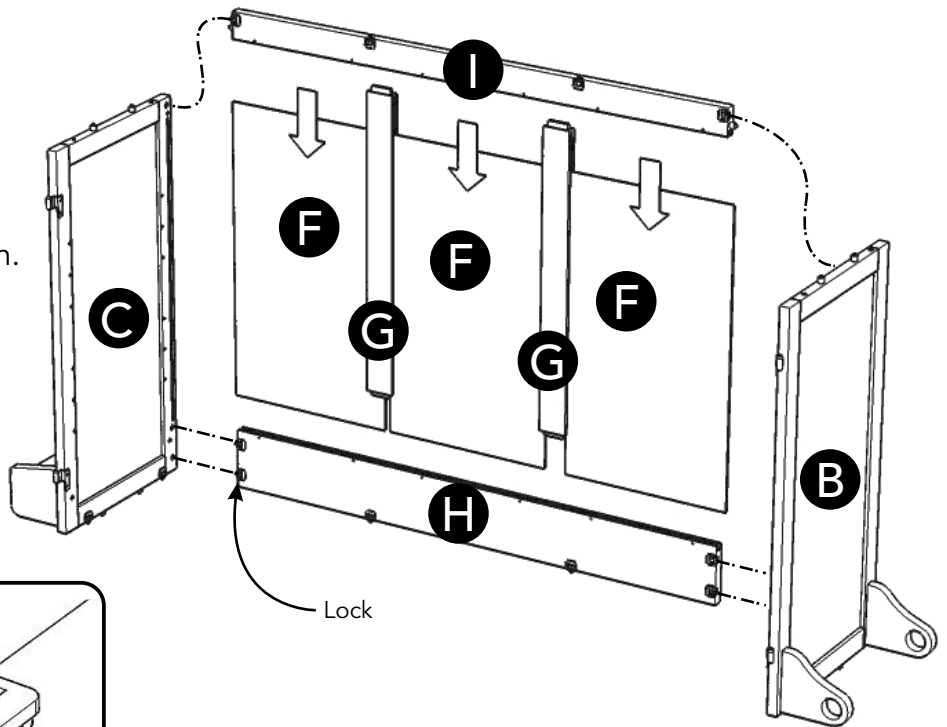

Figure 1

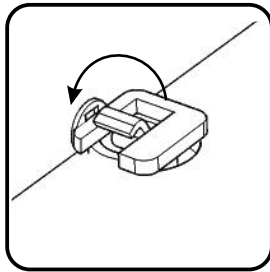
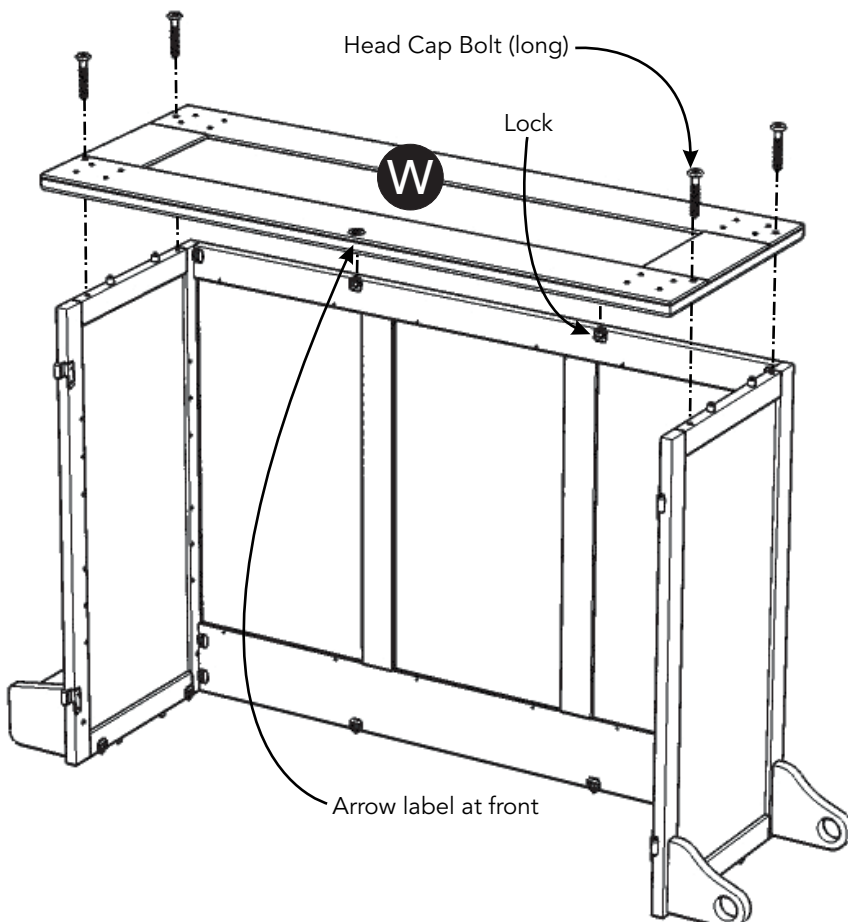

Figure 2



STEP 5

Attach Base (W) to unit with Head Cap Bolts (long), then flip the Locks. (See Figure 3)

Note: Arrow label indicates front of Base (W).

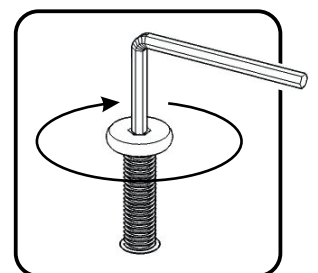

Figure 3

Assembly Instructions 4/7

STEP 6

Attach Casters to unit with Head Cap Bolts for Caster into pre-drilled holes, with Locking Casters at front. (See Figure 4)

Note: Arrow label indicates front of unit.

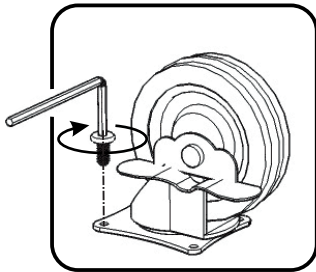
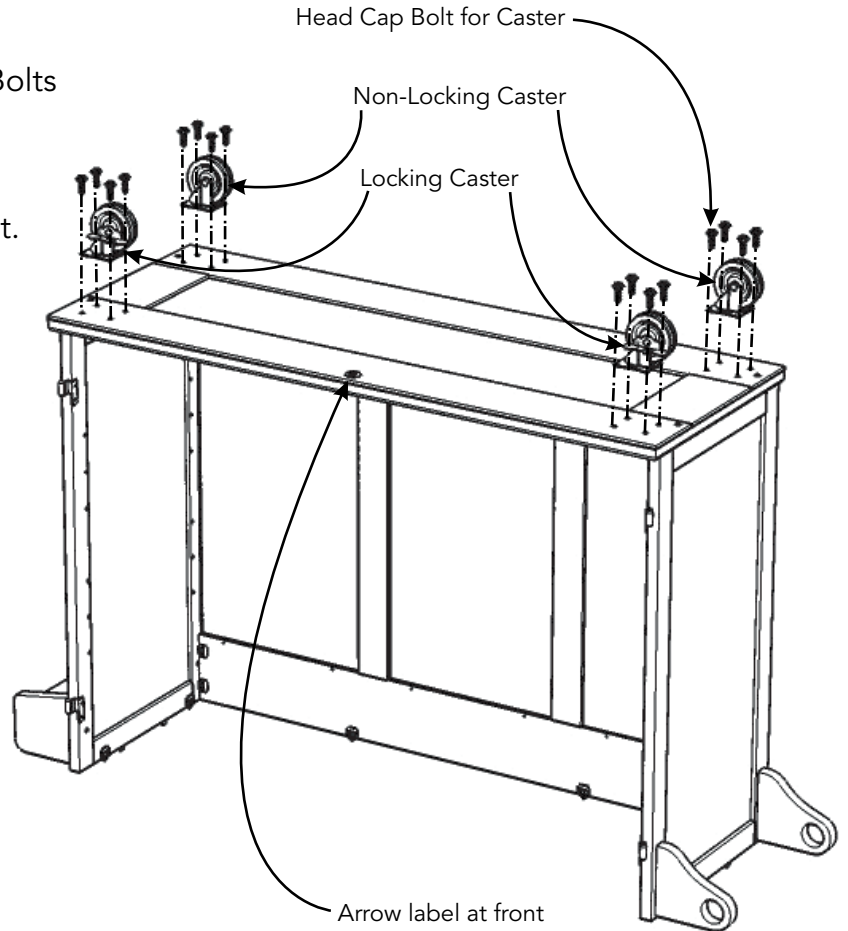

Figure 4



STEP 7

Turn unit over to its' upright position.

Attach Middle Panel (D) to unit, then flip the Locks.

Attach Front Rail (J) and Middle Panel (E) to unit, then flip the Lock.

Insert Wood Screws (short) into pre-drilled holes of unit.

Slide Towel Bar (L) into position.

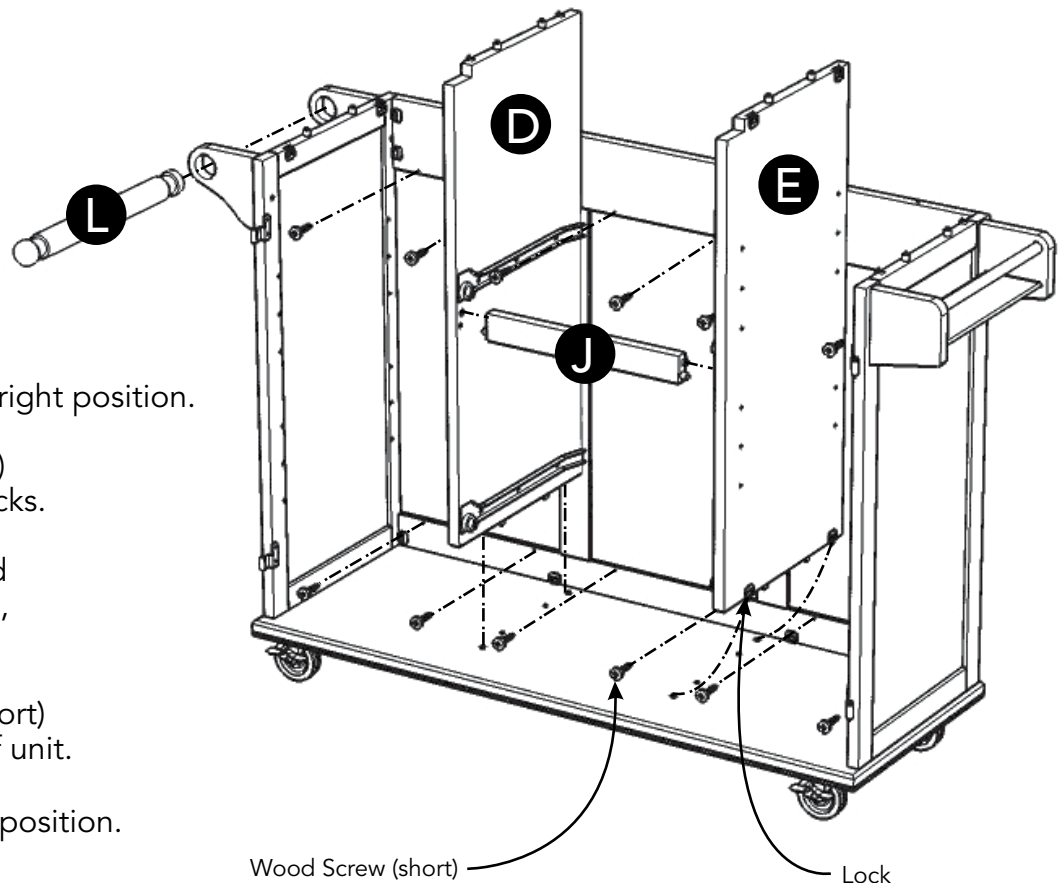

Assembly Instructions 5/7

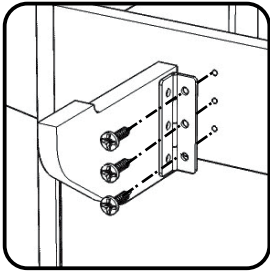

Figure 5

STEP 8

Attach Leaf Supports (U) and (V) to unit with Wood Screws for Leaf Support. (See Figure 5)

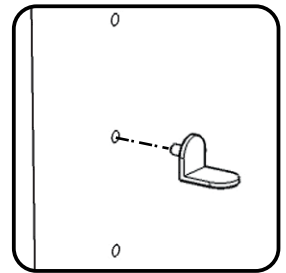
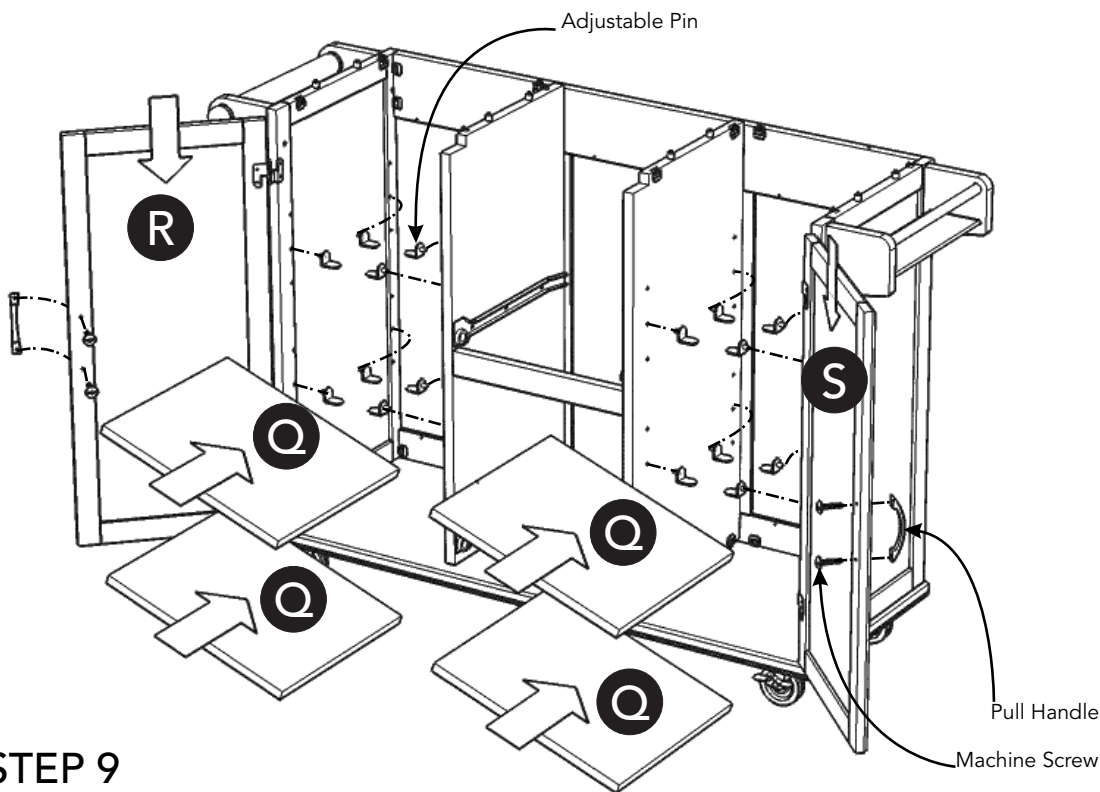
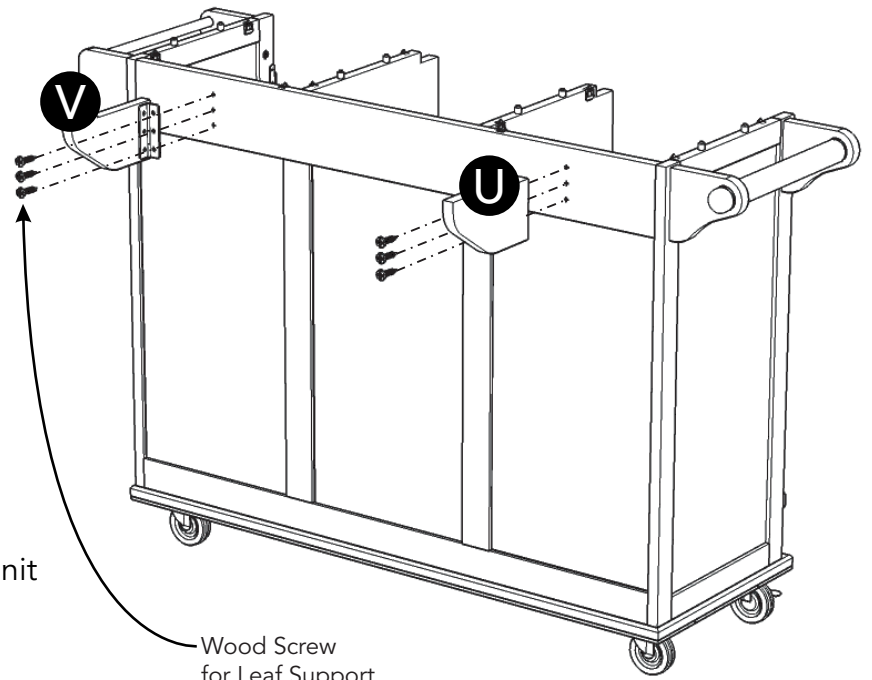

Figure 6

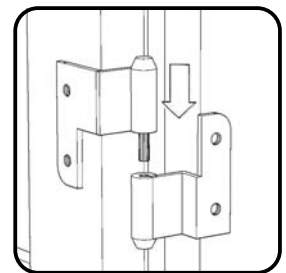

Figure 7

STEP 9

Insert Adjustable Pins into side panels and middle panels at desired level. (See Figure 6)

Place Shelves (Q) into position.

Attach Doors (R) and (S) by sliding door hinges into side panel hinges. (See Figure 7)

Attach Pull Handles to Doors (R) and (S) with Machine Screws. (See Figure 8)

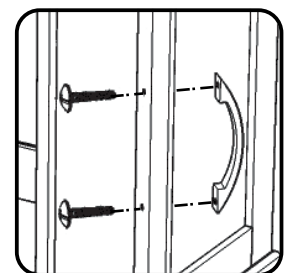
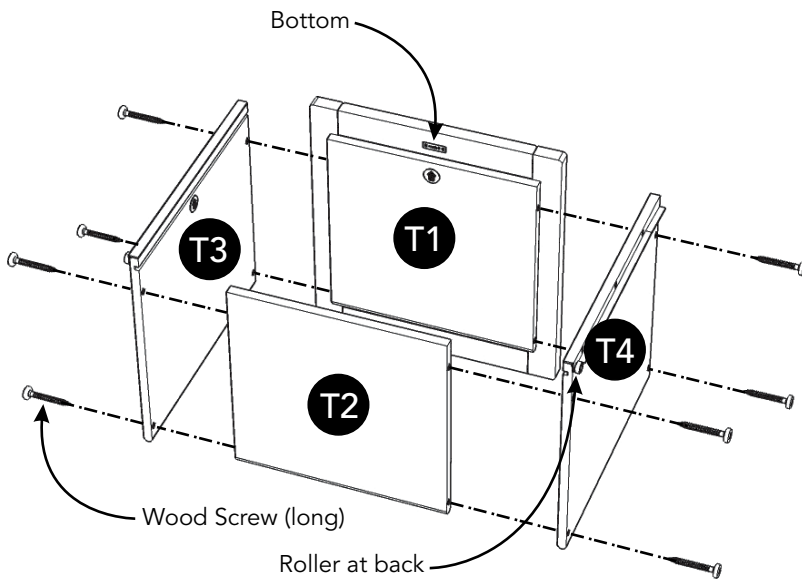
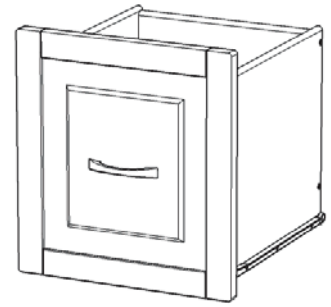

Figure 8

Assembly Instructions 6/7

Drawer (T)



STEP 10

Attach Drawer Front (T1) and Drawer Back (T2) to Drawer Side (T3) with Wood Screws (long).

Attach Drawer Side (T4) to unit with Wood Screws (long).

STEP 11

Slide Drawer Bottom (T5) into the grooves of Drawer Sides (T3) and (T4) until it meets Drawer Front (T1).

Attach Drawer Bottom (T5) to unit with Wood Screws (short).

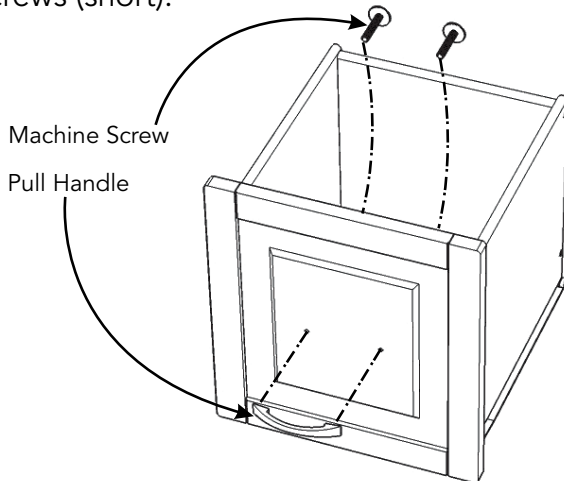
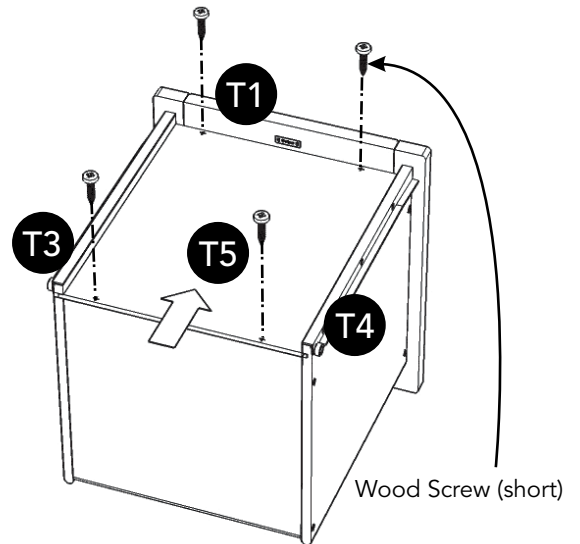

STEP 12

Attach Pull Handle with Machine Screws.

Part List

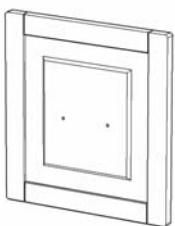

T1.
Drawer Front
2 pcs.



T2.
Drawer Back
2 pcs.



T3.
Drawer Side
2 pcs.



T4.
Drawer Side
2 pcs.



T5.
Drawer Bottom
2 pcs.

Assembly Instructions 7/7

STEP 13

Place Top (A) upside down on a soft cloth.

Attach Magnets to Top (A) by inserting Wood Screws for Magnet into pre-drilled holes. (See Figure 9)

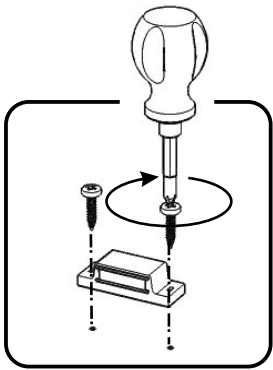
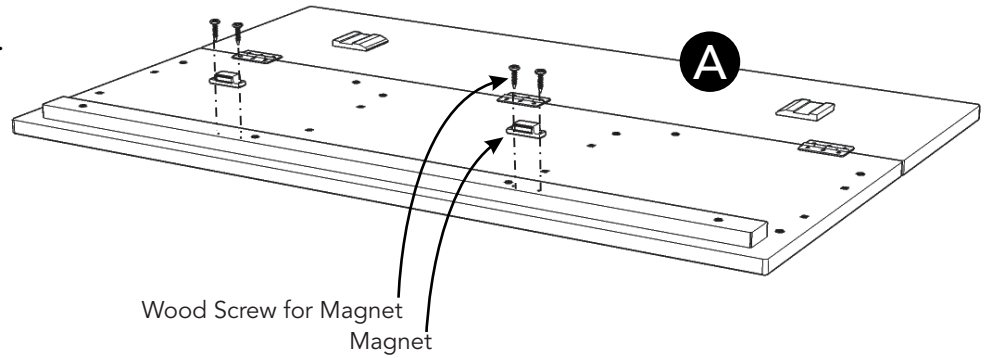
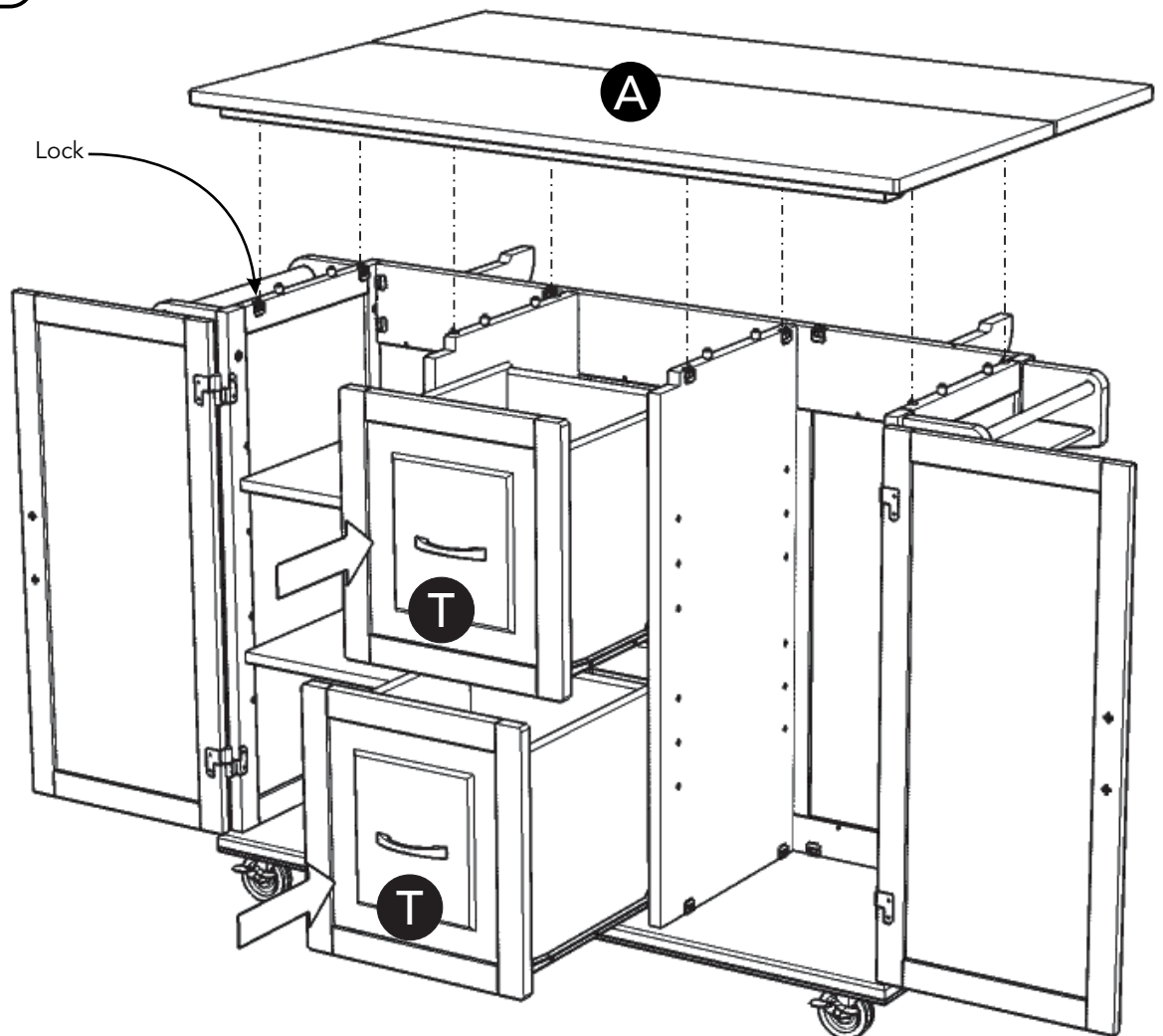

Figure 9



STEP 14

Attach Top (A) to unit, then flip the Locks.

Slide Drawers (T) into position.

CARE INSTRUCTIONS

NEVER

allow liquids to remain on furniture.
Absorption causes parts to warp
and split and finishes to delaminate.

NEVER

use glass cleaners on
finished furniture. Ammonia
chemically attacks the finish.



Do not use power tools
above 8 volts to assemble.
**PREVENT
CRACKING**



Do not place
in direct sunlight.
**PREVENT
FADING**



Do not write
directly on surface.
**PREVENT
MARKING**



Do not place hot
objects on surface.
**PREVENT
FINISH DAMAGE**

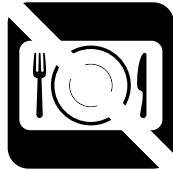

Do not use rubber
based placemats.
**PREVENT
DISCOLORING**



Do not use commercial
waxes and polishes.
**PREVENT
YELLOWING**

CLEAN

with a soft cloth moistened
in lukewarm soap and water.
Buff with a dry clean cloth.

