

# Over Commode Stand

## IMPORTANT

Carefully remove all the parts from the carton and place them individually on a soft cloth to prevent scratches or other damage.

Carefully and strictly follow these assembly instructions to ensure a completed product as designed.

Do not use power tools above 8 volts to assemble.

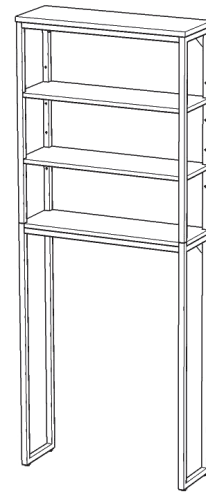

## Part List



A.  
Top  
1 pc.



B.  
Shelf  
2 pcs.



C.  
Shelf  
1 pc.



H.  
Front Stretcher  
2 pcs.

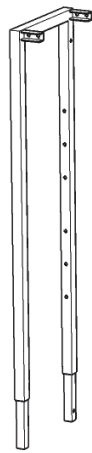

D.  
Side Frame  
1 pc.



E.  
Side Frame  
1 pc.

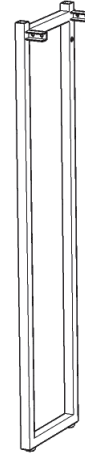

F.  
Side Frame  
1 pc.

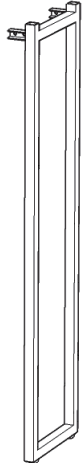

G.  
Side Frame  
1 pc.



I.  
Back Stretcher  
2 pcs.

## Hardware List

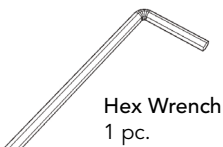

Hex Wrench  
1 pc.



Small Hex Wrench  
1 pc.

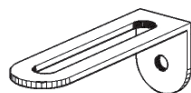

Steel Plate  
2 pcs.

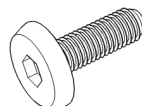

M6x16  
Head Cap Bolt  
32 pcs. (+1 extra)



Spring Washer  
32 pcs. (+1 extra)



Flat Washer  
32 pcs. (+1 extra)

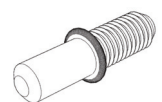

Adjustable Pin  
8 pcs. (+1 extra)

Tool(s) required for assembly: Phillips screwdriver, Level, Drill (8 volts or less), 3/8" Drill Bit, Pencil

# Assembly Instructions 2/4

## IMPORTANT

- Use a soft cloth between these parts and the floor.
- Do not use power tools above 8 volts to assemble.
- Do not tighten all the bolts until each part is properly assembled.
- The unit must be level to work properly. Use the included adjustable levelers to level.
- Keep Hex Wrench in a safe place as the bolts may need to be tightened up in the future.

## STEP 1

Attach Side Frames (D) to Side Frame (F) with Flat Washer, Spring Washer and Head Cap Bolt, tightening the bolt only half way. (See Figure 1)

Attach Steel Plates to Back Stretcher (I) with Flat Washers, Spring Washers and Head Cap Bolts. (See Figure 2)

Attach Front Stretchers (H) and Back Stretchers (I) to unit with Flat Washers, Spring Washers and Head Cap Bolts, tightening the bolts only half way.

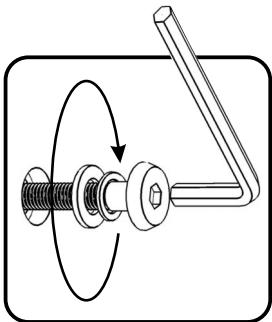
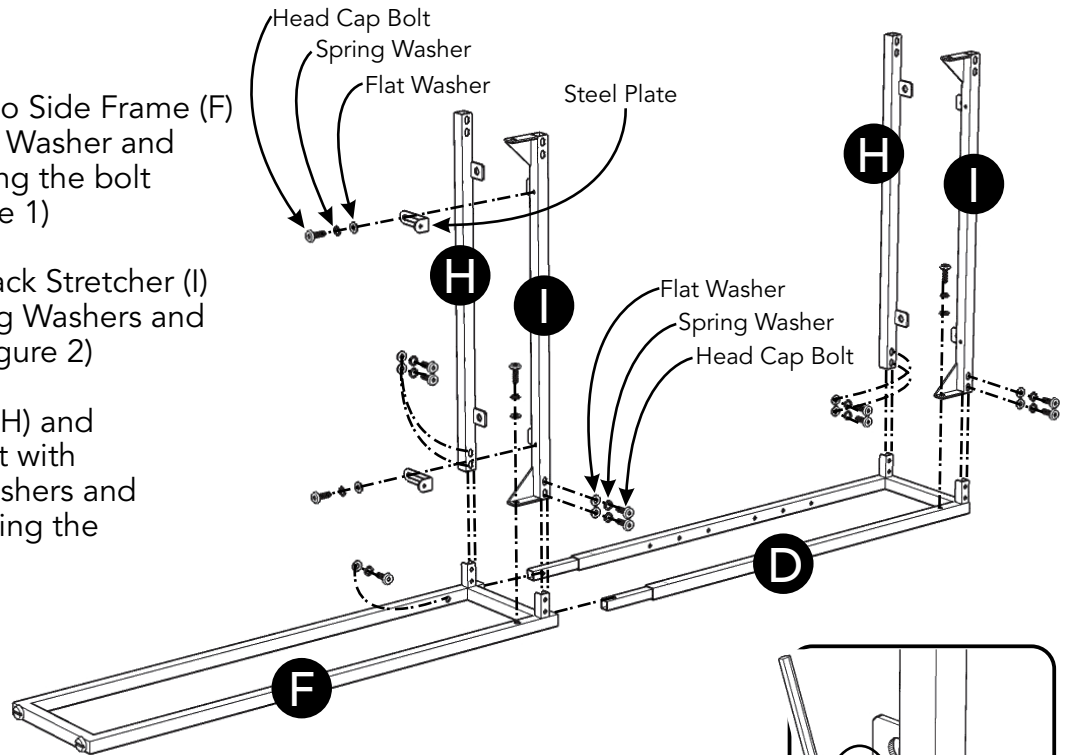

Figure 1

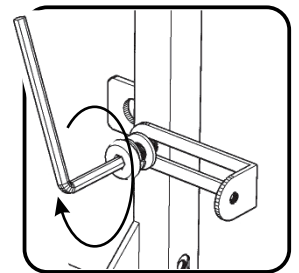
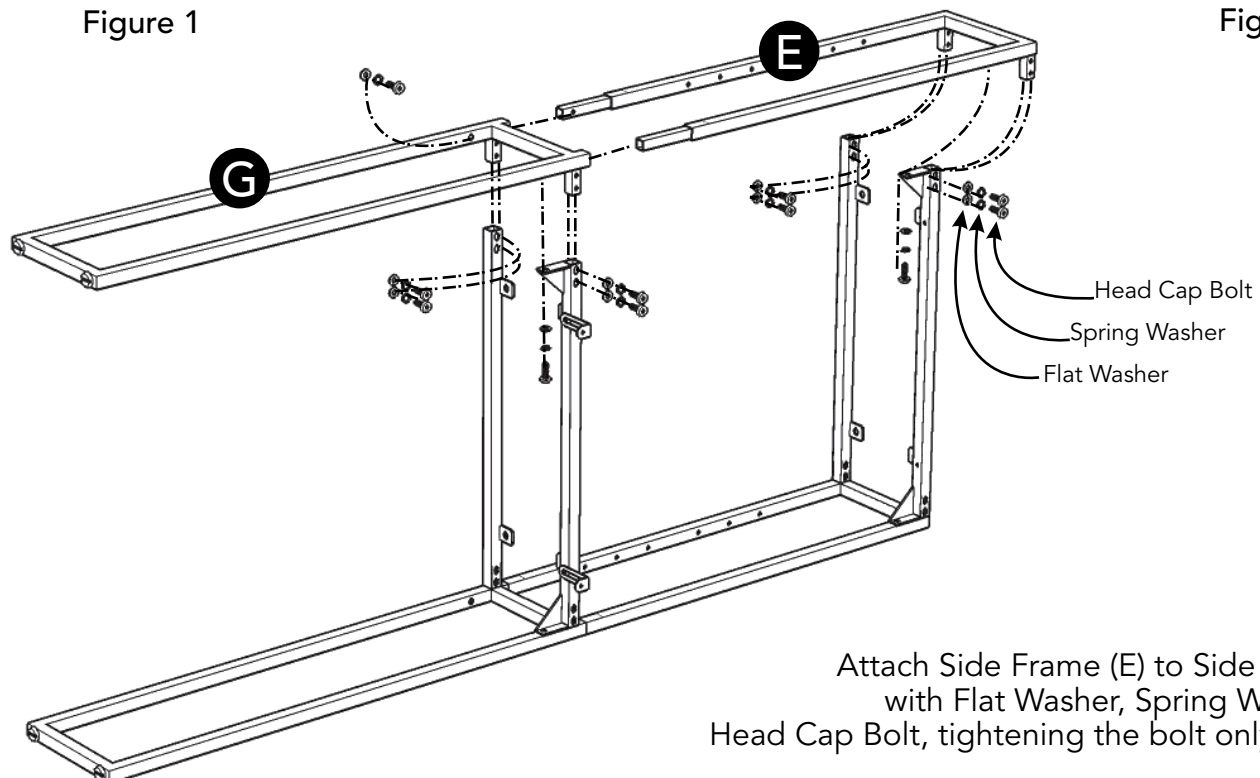

Figure 2



## STEP 2

Attach Side Frame (E) to Side Frame (G) with Flat Washer, Spring Washer and Head Cap Bolt, tightening the bolt only half way.

Attach unit to unit from Step 1 with Flat Washers, Spring Washers and Head Cap Bolts, tightening the bolts only half way.

## Assembly Instructions 3/4

### STEP 3

Attach Top (A) and Shelf (C) to unit with Flat Washers, Spring Washers and Head Cap Bolts, tightening the bolts only half way.

Tighten all Head Cap Bolts used in all steps.

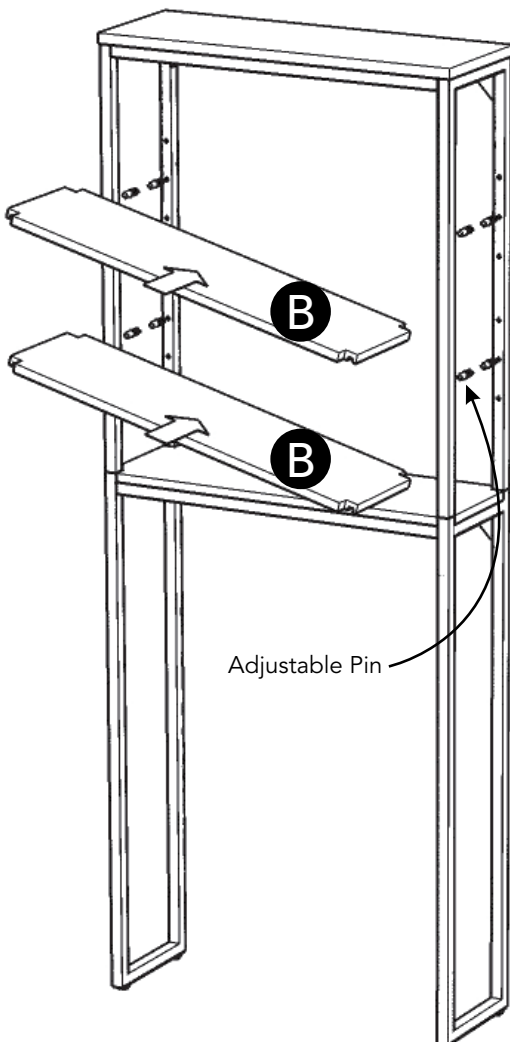
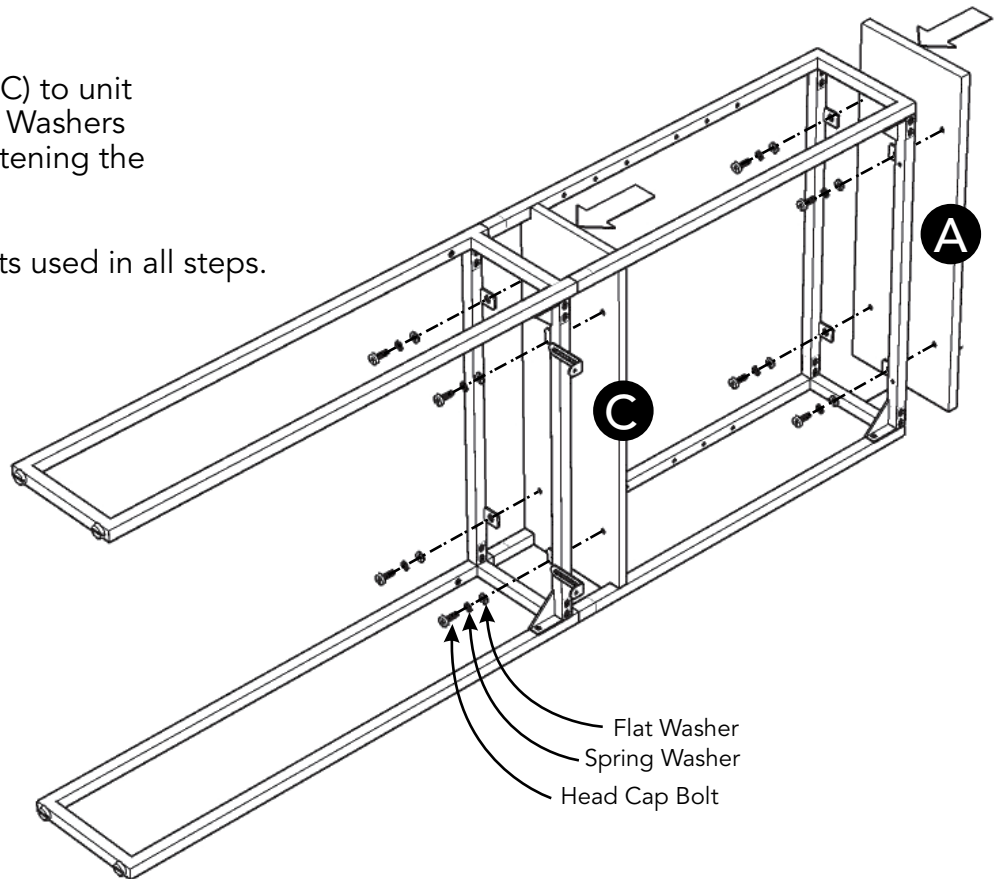

### STEP 4

Turn unit to its' upright position.

Insert Adjustable Pins into unit at desired level.  
(See Figure 3)

Place Shelves (B) into position.

Level unit by adjusting the adjustable levels  
on the bottom of unit. (See Figure 4)

Note: Unit must be level to work properly.

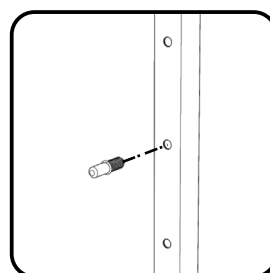

Figure 3

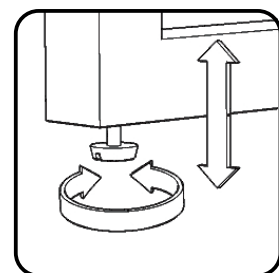

Figure 4

# Assembly Instructions 4/4

## IMPORTANT

- To help reduce the risk of the unit tipping over, the Tip-over Restraint must be installed following these instructions exactly.

## STEP 5

Place unit at desired location.

Loosen slightly the Head Cap Bolts attaching Steel Plates to the unit, slide the Steel Plates to the wall, then re-tighten the Head Cap Bolts.

Mark wall with pencil in the Steel Plates screw holes. (See Figure 5)

Move unit.

Drill 3/8" holes in wall at pencil marks.

Insert Anchors into the wall holes.

Move unit back into place.

Attach Steel Plates to wall with Wall Screws. (See Figure 6)

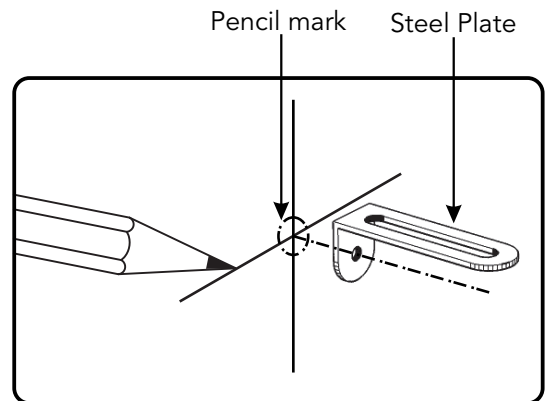

Figure 5

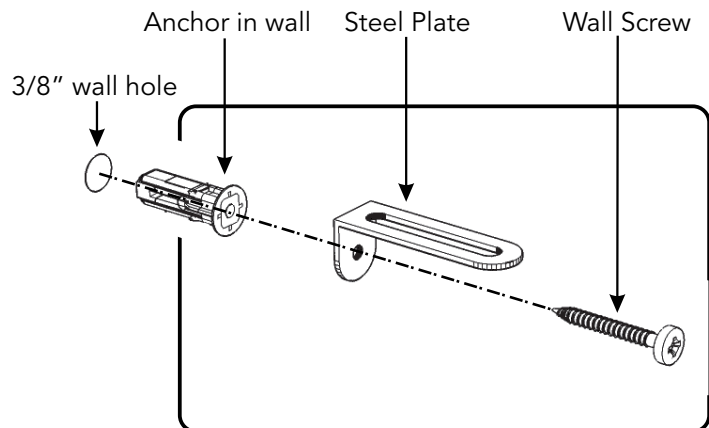
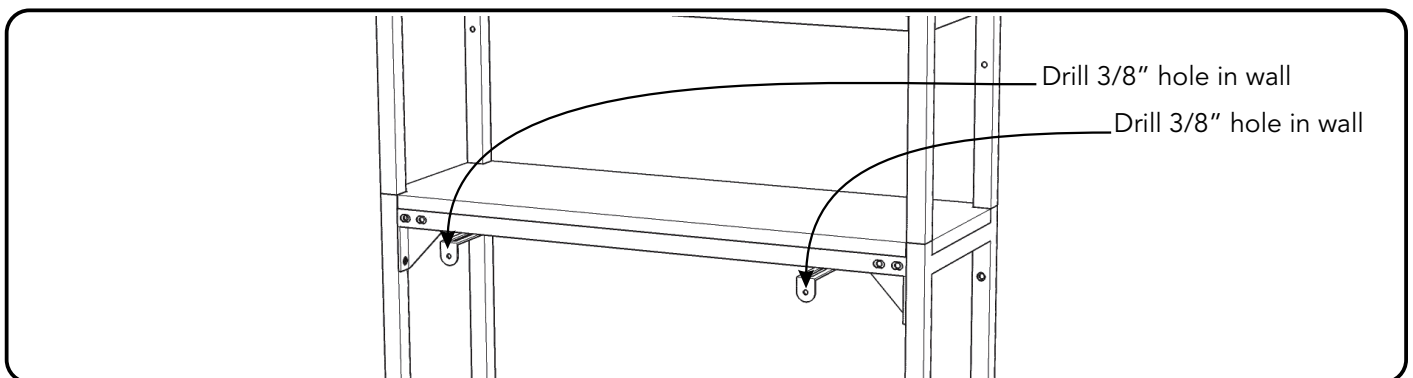
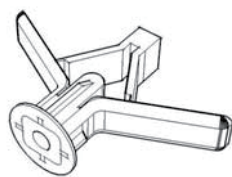

Figure 6



## Hardware List



Anchor  
2 pcs. (+1 extra)

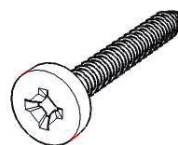

M3.5x40  
Wall Screw  
2 pcs. (+1 extra)

# CARE INSTRUCTIONS

## NEVER

allow liquids to remain on furniture.  
Absorption causes parts to warp  
and split and finishes to delaminate.

## NEVER

use glass cleaners on  
finished furniture. Ammonia  
chemically attacks the finish.



Do not use power tools  
above 8 volts to assemble.  
**PREVENT  
CRACKING**



Do not place  
in direct sunlight.  
**PREVENT  
FADING**



Do not write  
directly on surface.  
**PREVENT  
MARKING**



Do not place hot  
objects on surface.  
**PREVENT  
FINISH DAMAGE**

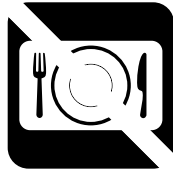

Do not use rubber  
based placemats.  
**PREVENT  
DISCOLORING**



Do not use commercial  
waxes and polishes.  
**PREVENT  
YELLOWING**

## CLEAN

with a soft cloth moistened  
in lukewarm soap and water.  
Buff with a dry clean cloth.

