

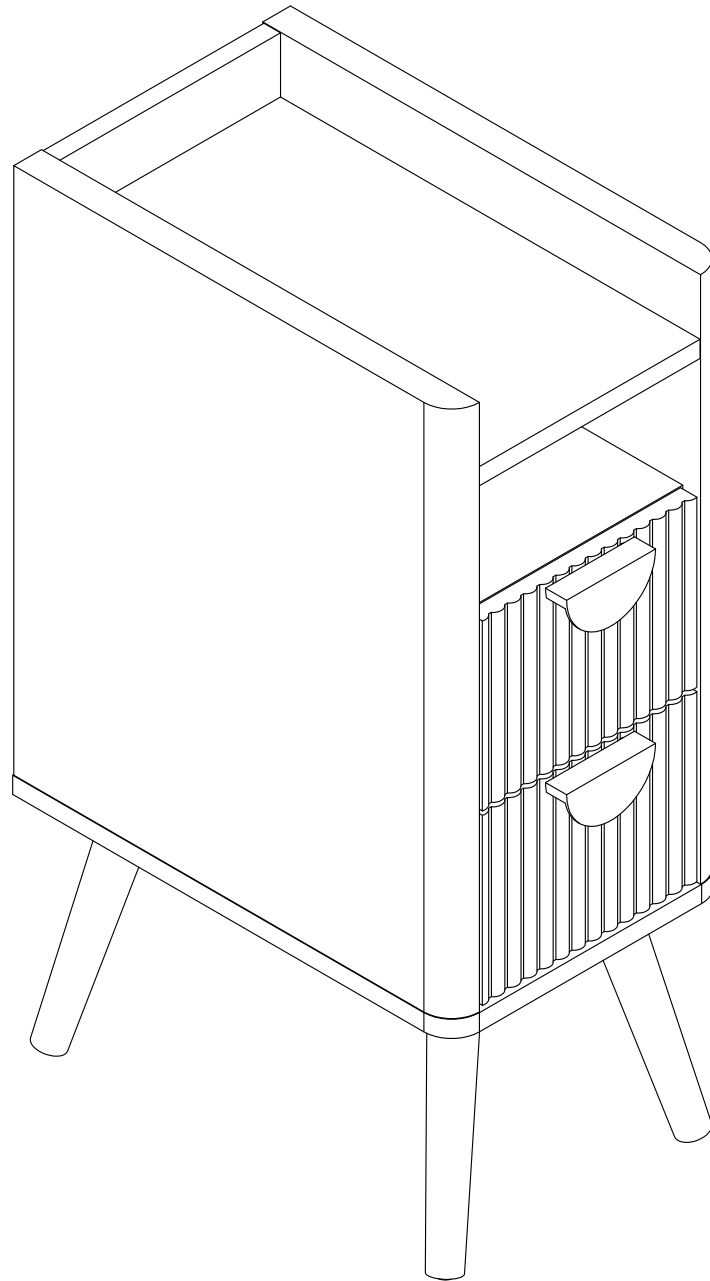









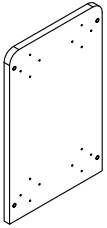
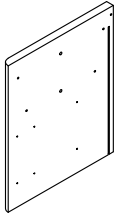
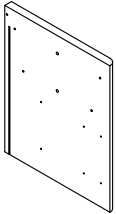
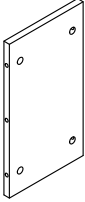
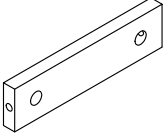
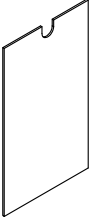
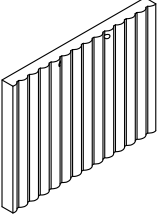
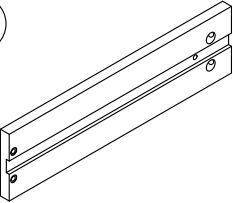
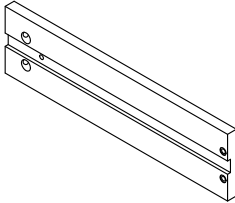
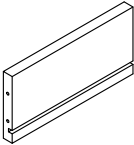
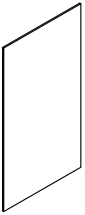





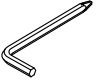
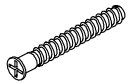

# Assembly Instruction

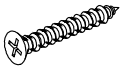

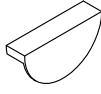
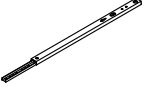
<p>①</p> 	<p>②</p> 	<p>③</p> 	<p>④</p> 
<p>1PC</p>	<p>1PC</p>	<p>1PC</p>	<p>1PC</p>
<p>⑤</p> 	<p>⑥</p> 	<p>⑦</p> 	<p>⑧</p> 
<p>1PC</p>	<p>1PC</p>	<p>1PC</p>	<p>2PCS</p>
<p>⑨</p> 	<p>⑩</p> 	<p>⑪</p> 	<p>⑫</p> 
<p>2PCS</p>	<p>2PCS</p>	<p>2PCS</p>	<p>2PCS</p>
<p>⑬</p> 			
<p>4PCS</p>			

<b>A</b>	X18	<b>B</b>	X10	<b>C</b>	X12	<b>D</b>	X4	<b>E</b>	X1	<b>F</b>	X5
											
M6x35mm		Ø15x9mm		M3.5x14mm		M3x16mm		4mm		M5x40mm	
<b>G</b>	X6	<b>H</b>	X4	<b>I</b>	X4	<b>J</b>	X4	<b>K</b>	X9	<b>M</b>	X4
											
Ø8x30mm		M4x10mm				M4x18mm		M4x35mm			
<b>N</b>	X2	<b>O</b>	X4	<b>P</b>	X17	<b>Q</b>	X8	<b>S</b>	X1	<b>T</b>	X1
											
				M4x14mm		Ø12x9mm				Ø6x30mm	

## Cam Lock Fastening System

Insert the cam bolt into the hole first, then insert the cam lock and lock it.

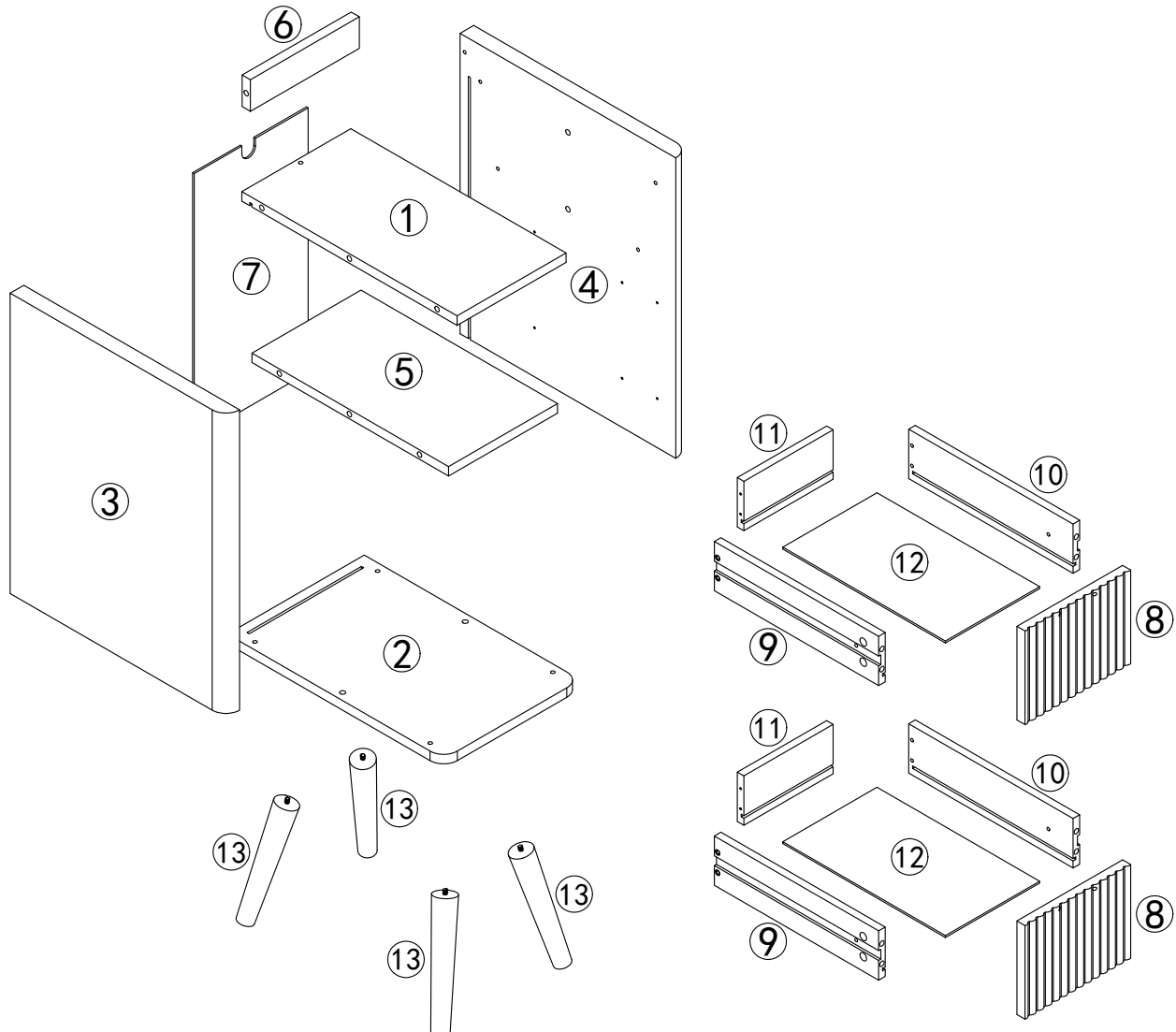
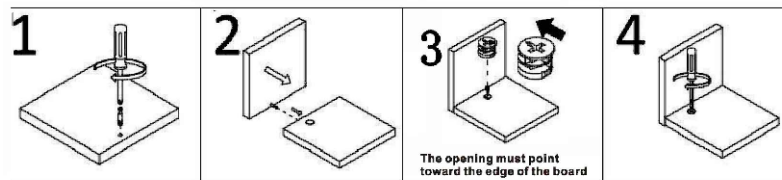

1

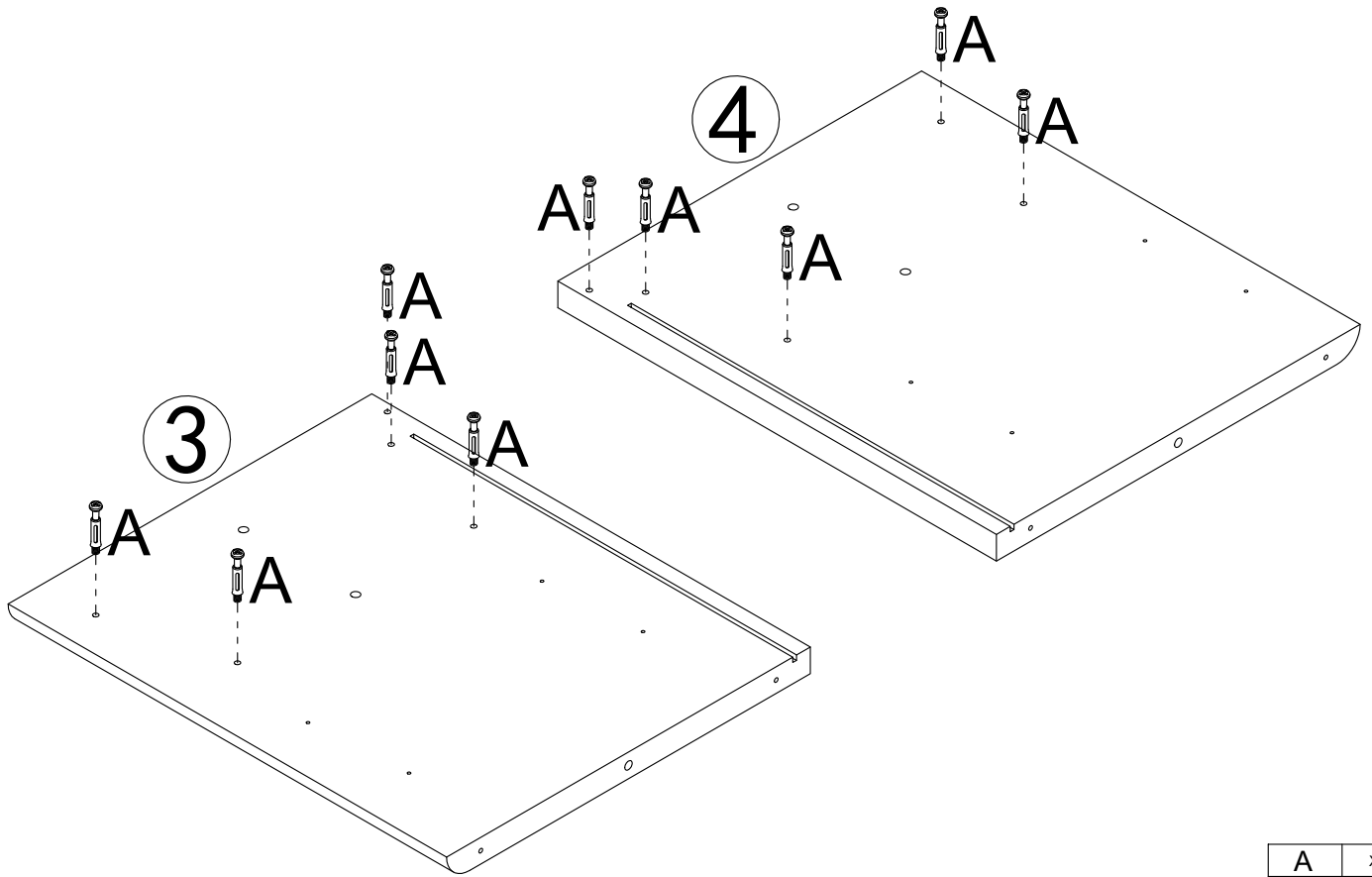

A	X10
	
M6x35mm	

2

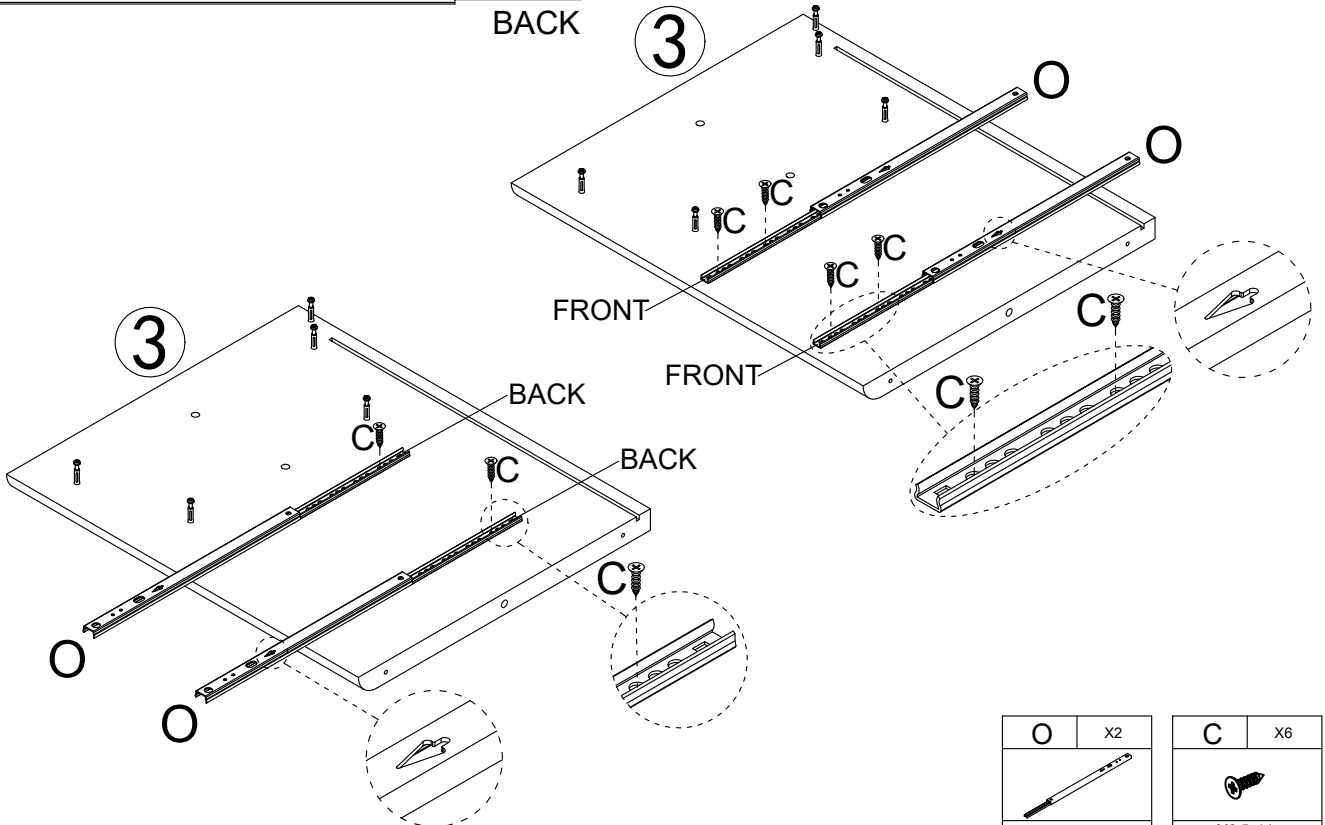
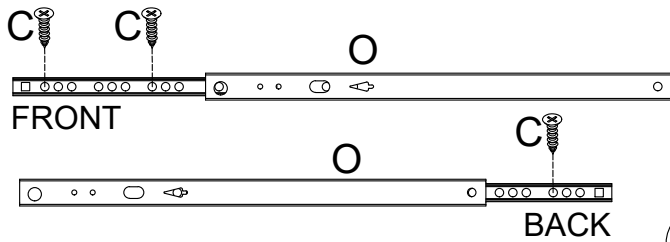

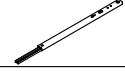
O	X2
	

C	X6
	
M3.5x14mm	

3

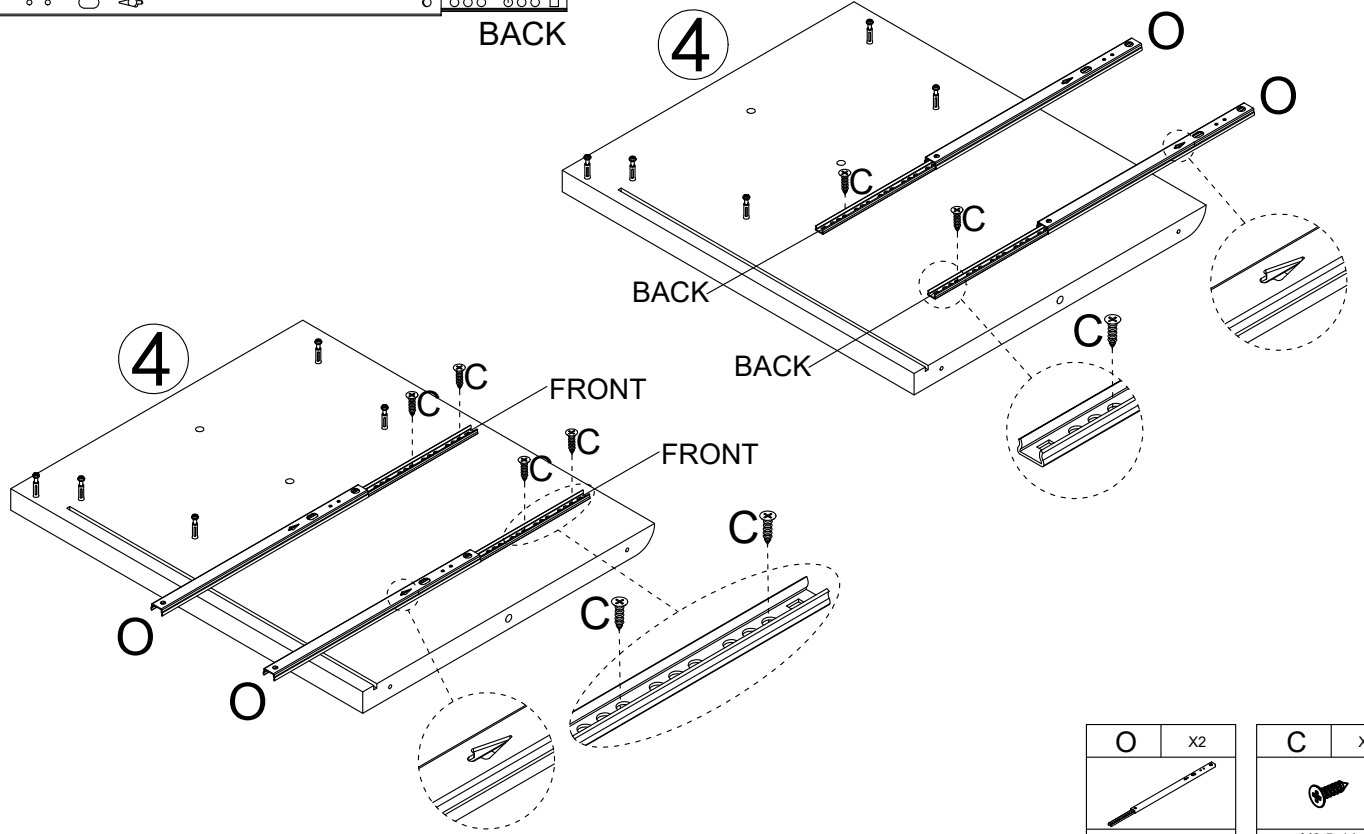
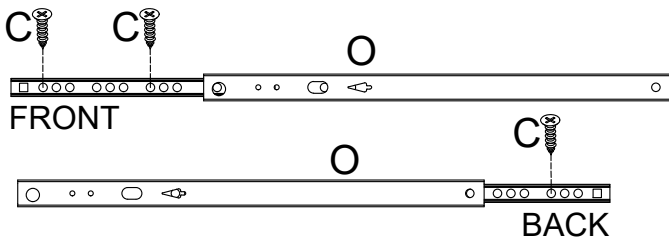

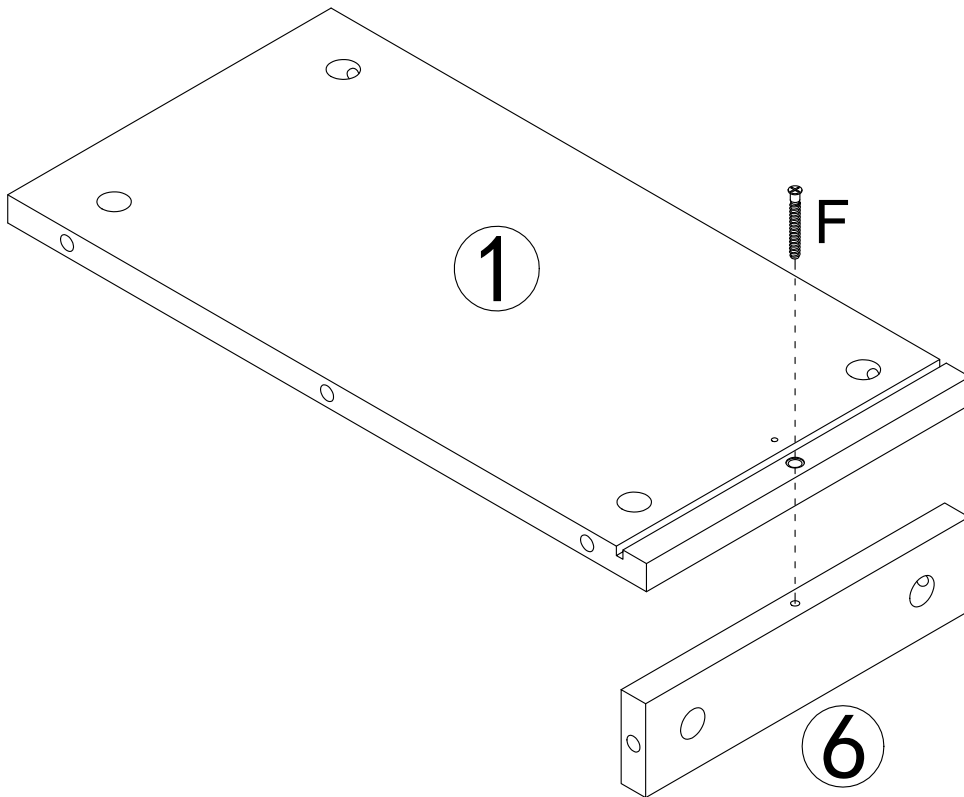

4

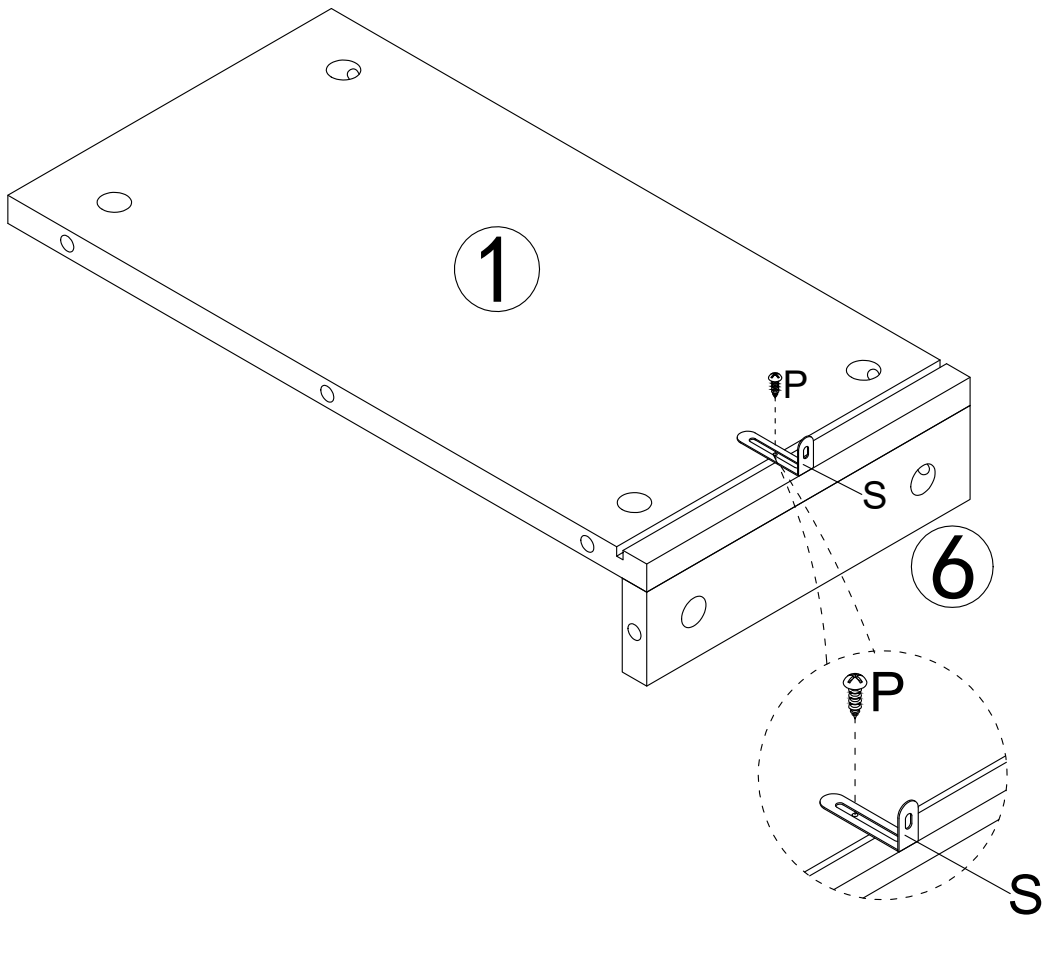

F	X1
M5x40mm	

5





P	x1
	
M4x14mm	

S	x1
	

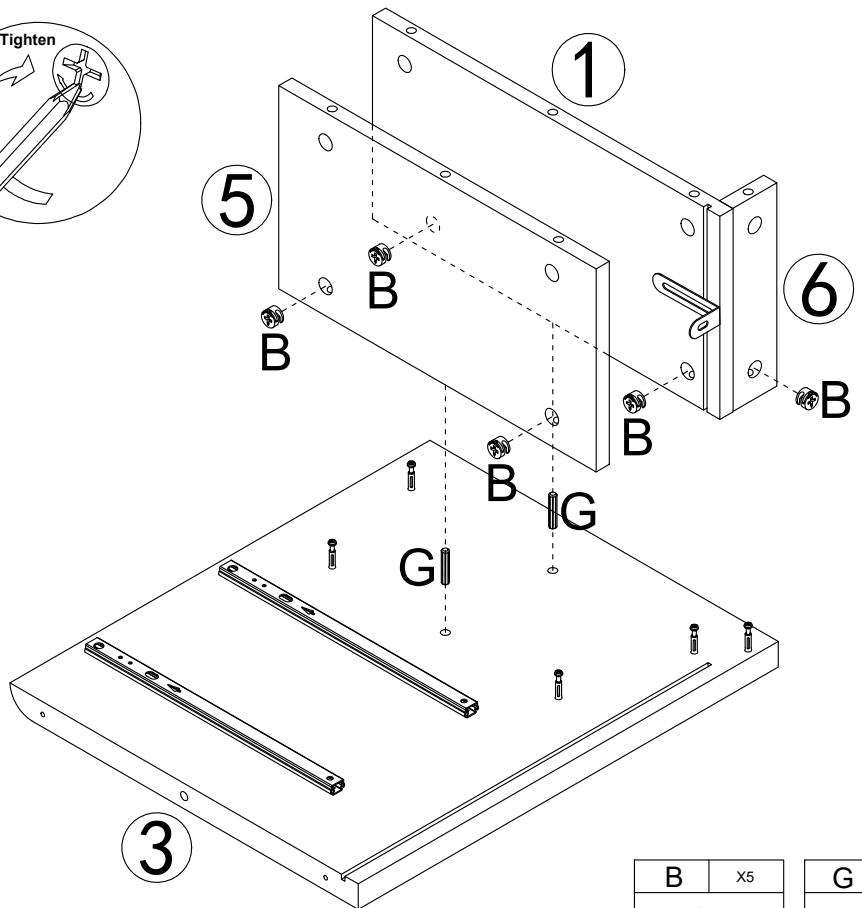
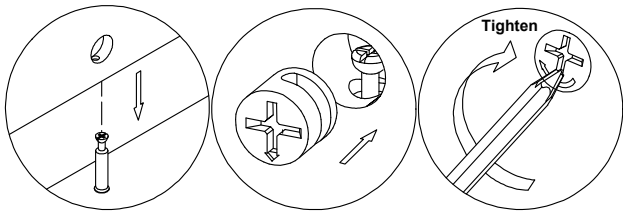
6





B	x5
	
Ø15x9mm	

G	x2
	
Ø8x30mm	

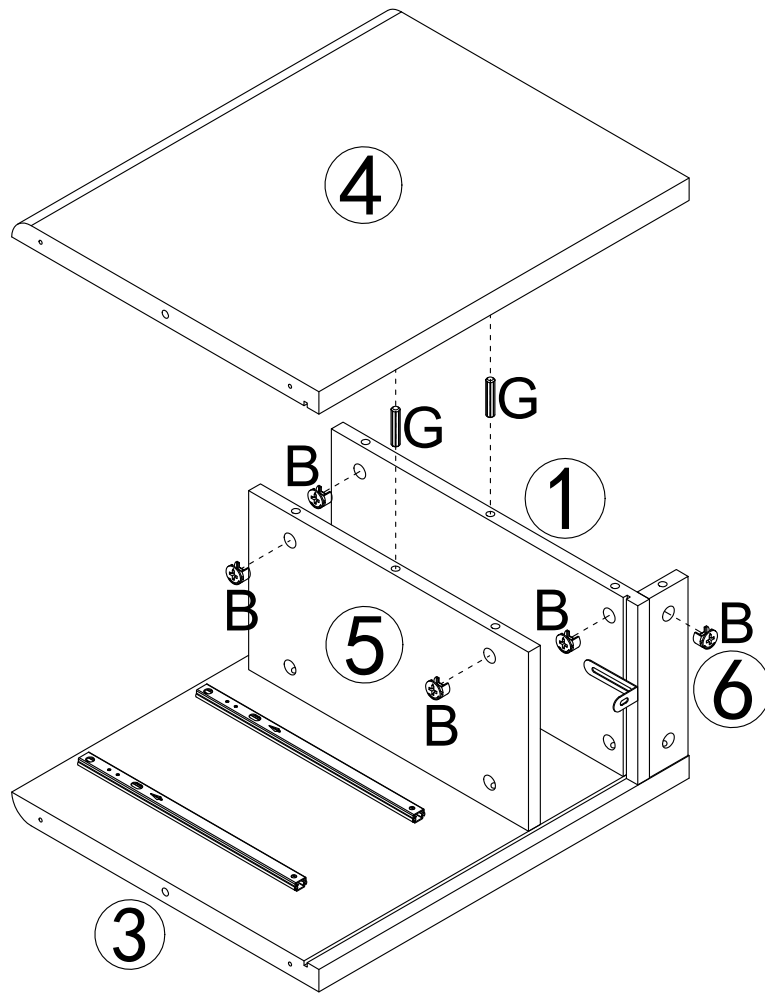
7



B	X5
	
Ø15x9mm	

G	X2
	
Ø8x30mm	

8

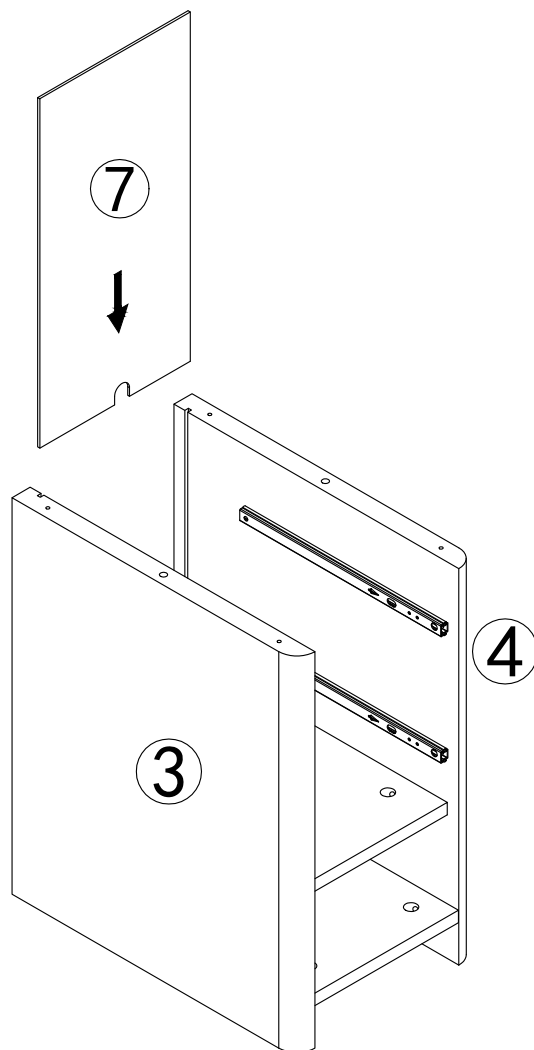

9

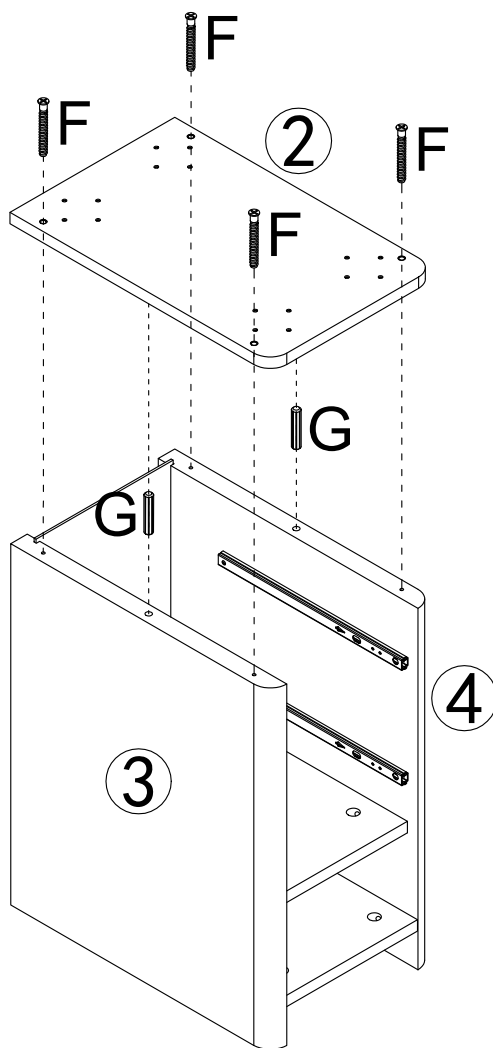

G	X2	F	X4
Ø8x30mm		M5x40mm	

10

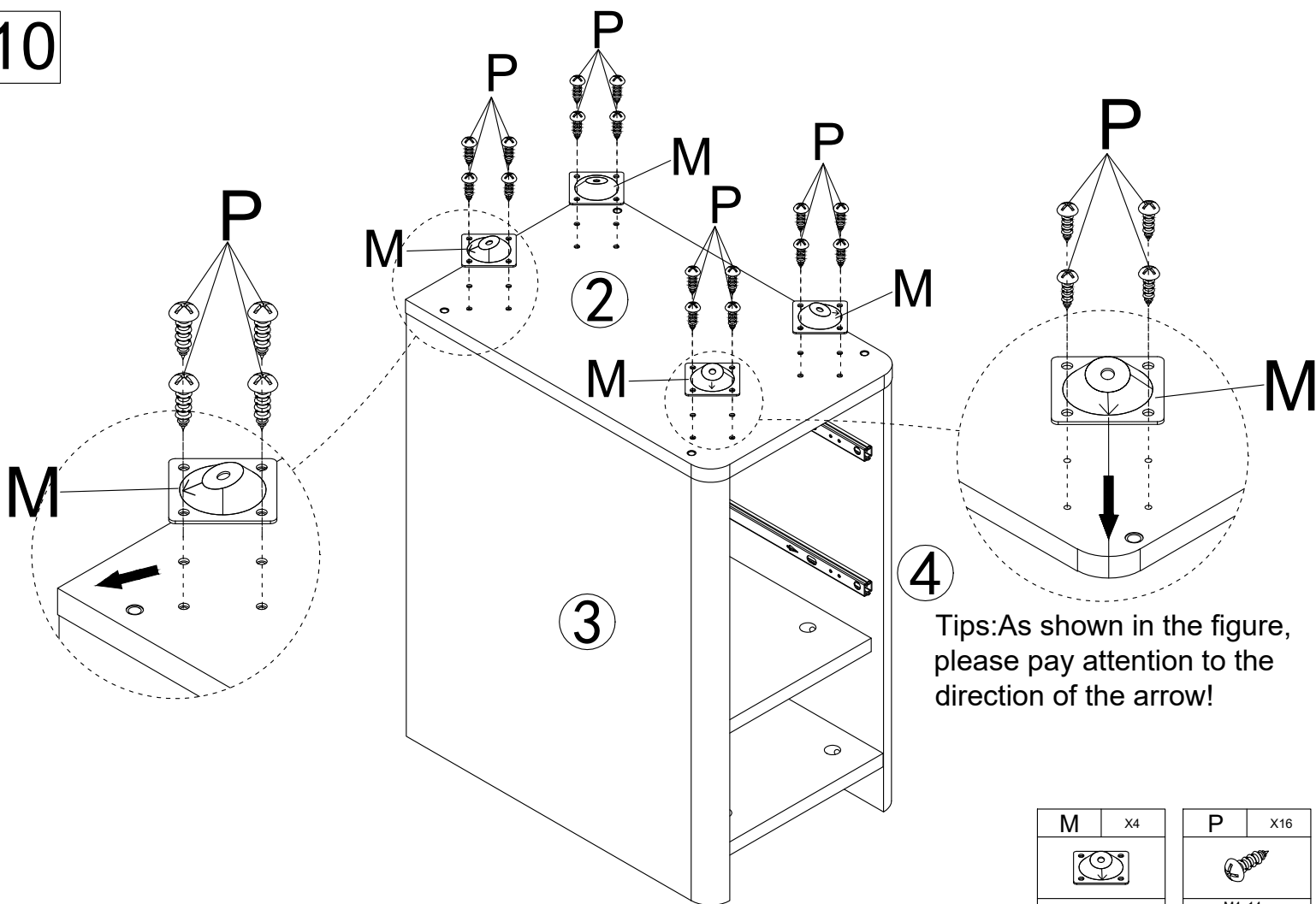

Tips: As shown in the figure, please pay attention to the direction of the arrow!

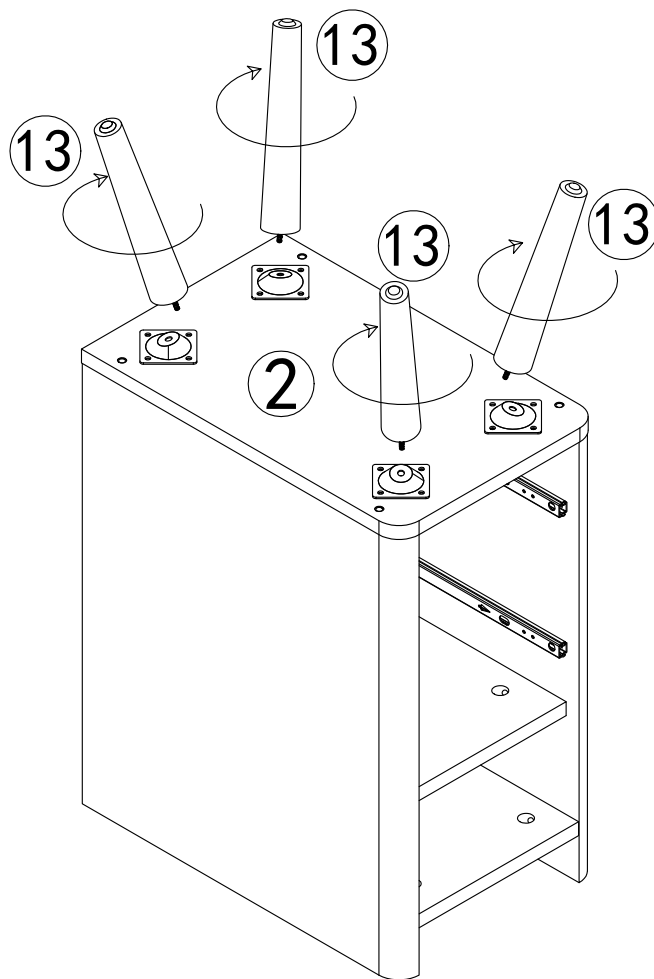

M	X4	P	X16
		M4x14mm	

11



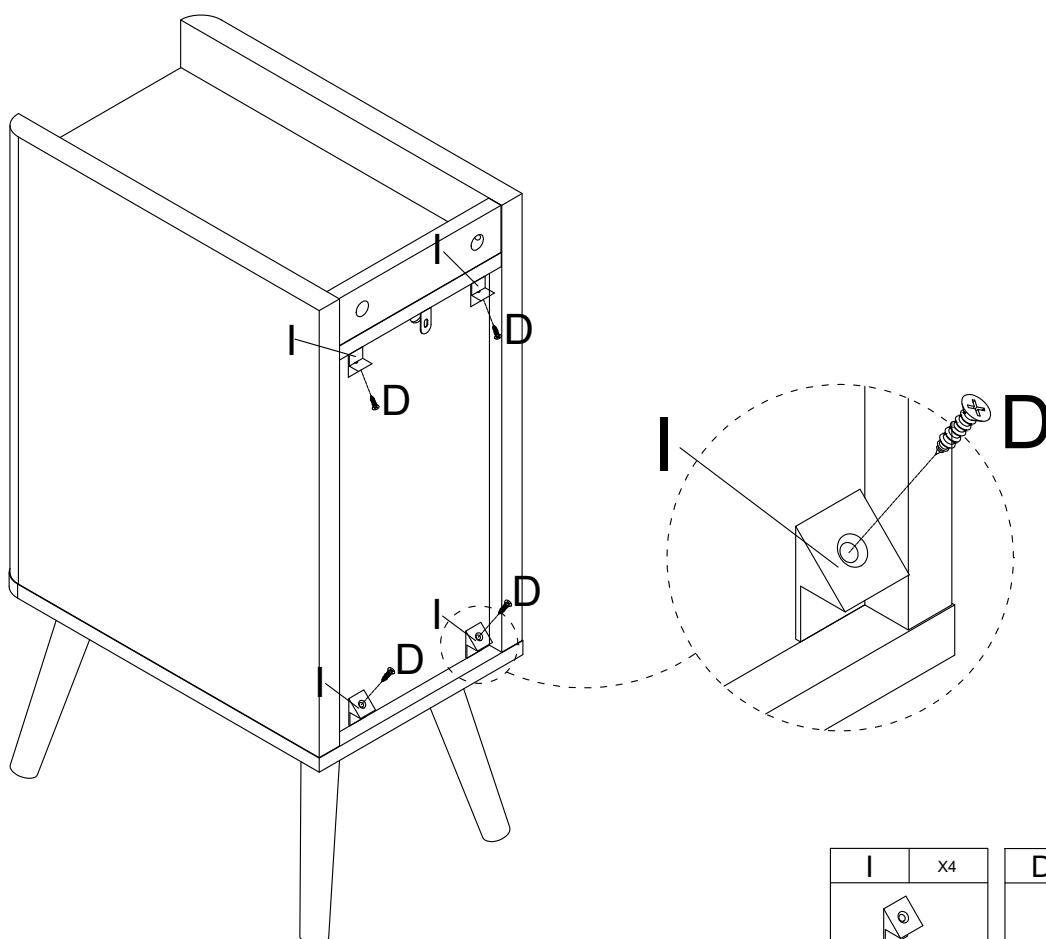

12

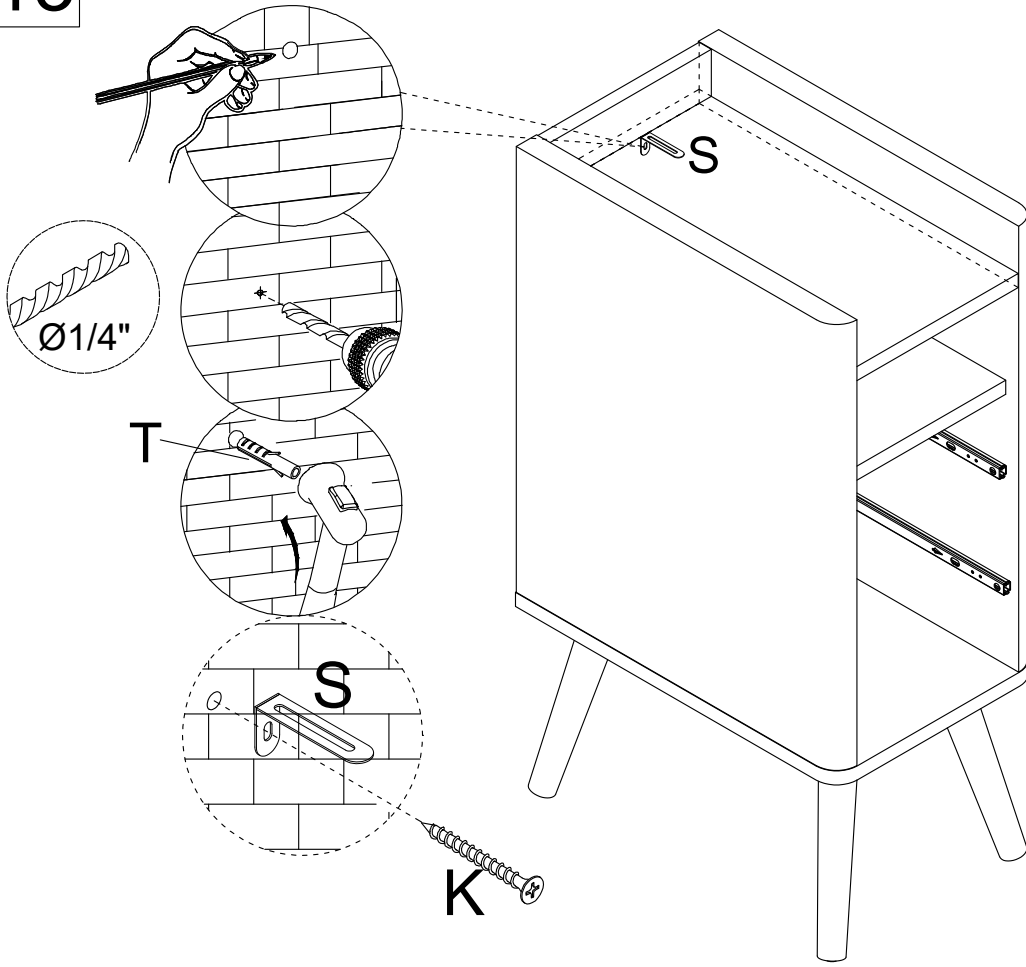

I	x4	D	x4
			
		M3x16mm	

13



K	x1
	
M4x35mm	

T	x1
	
Ø6x30mm	

14

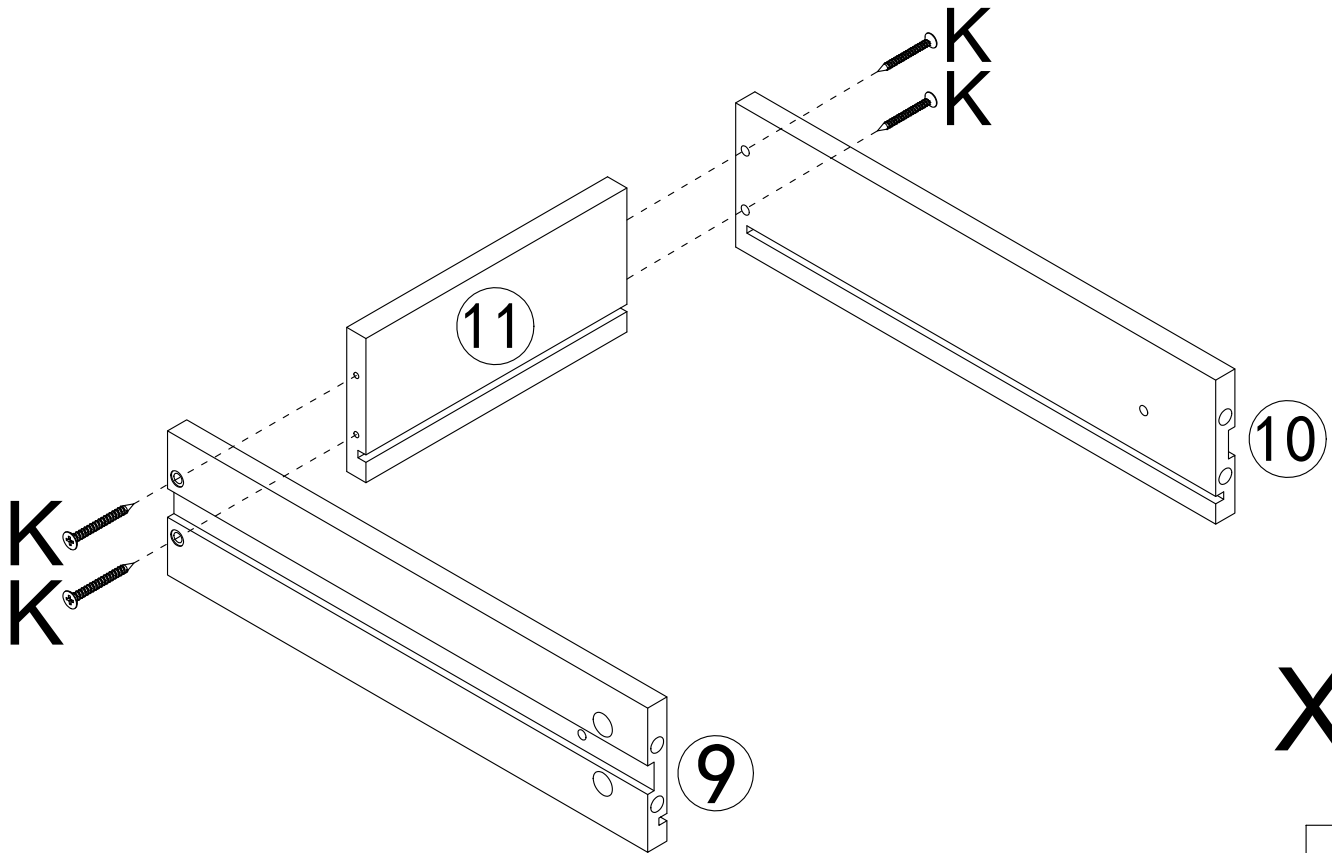

X2

K	x8
	
M4x35mm	

15

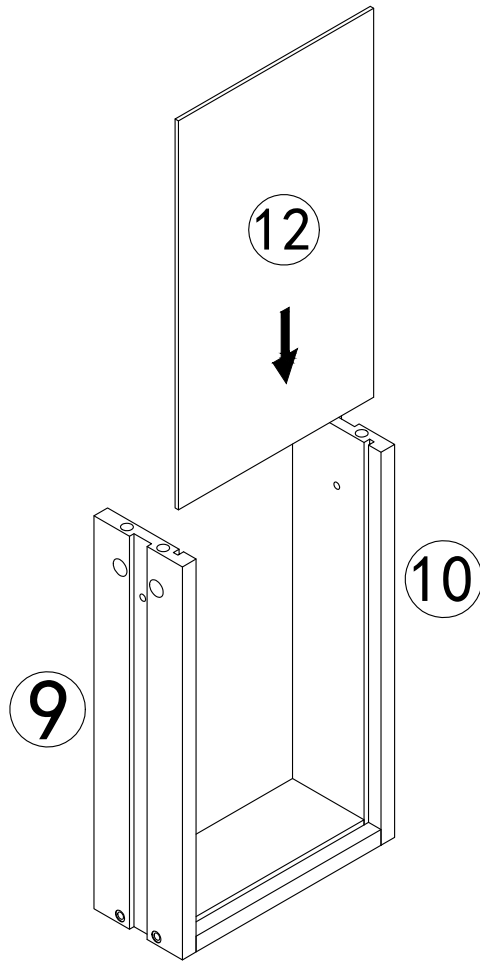



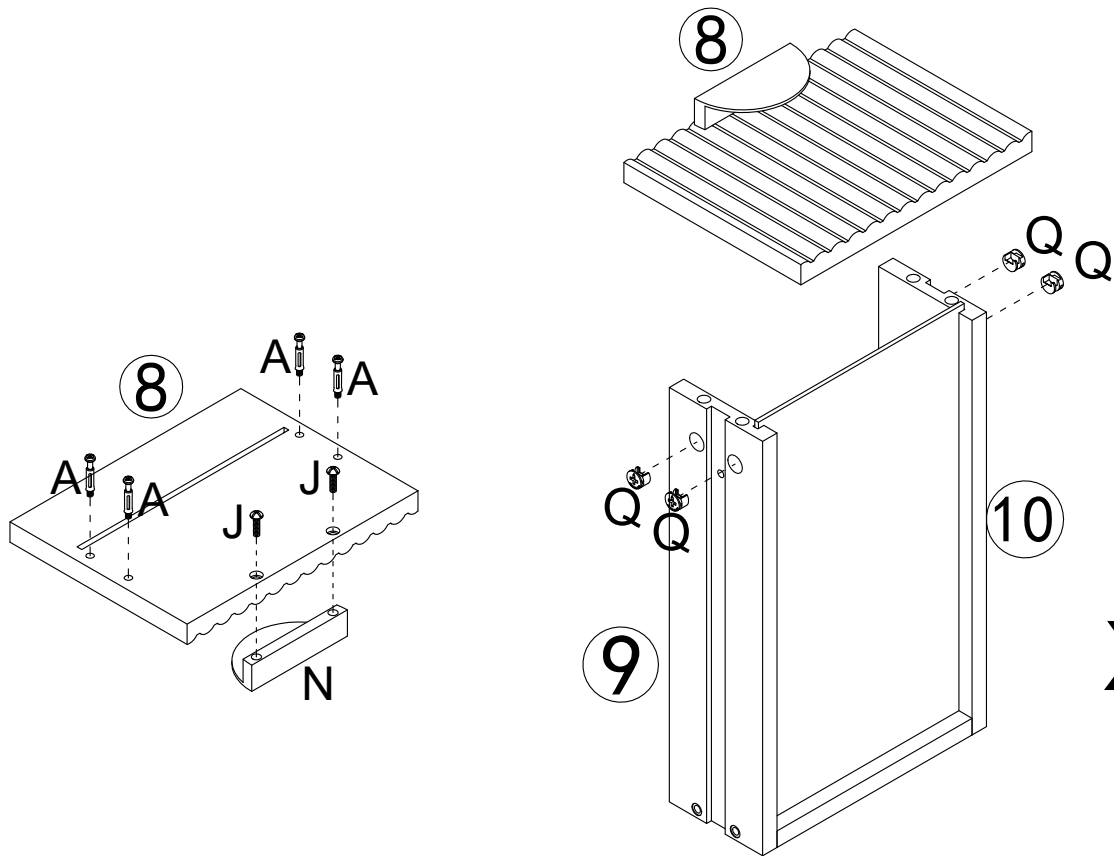

X2

16



X2

J	x4	N	x2	A	x8	Q	x8
							
M4x18mm				M6x35mm		Ø12x9mm	

17

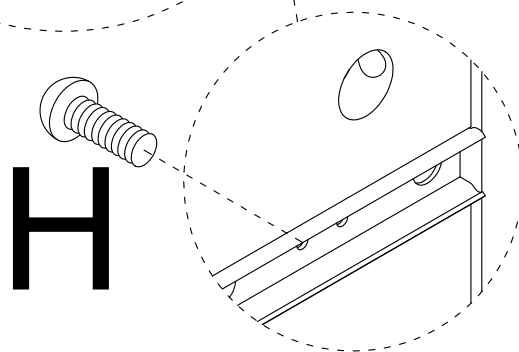
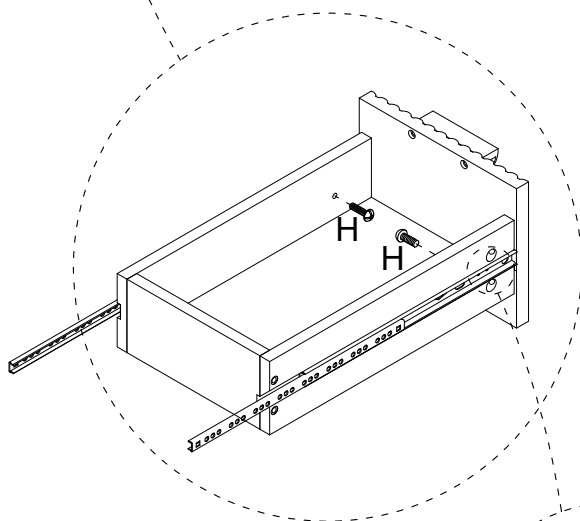
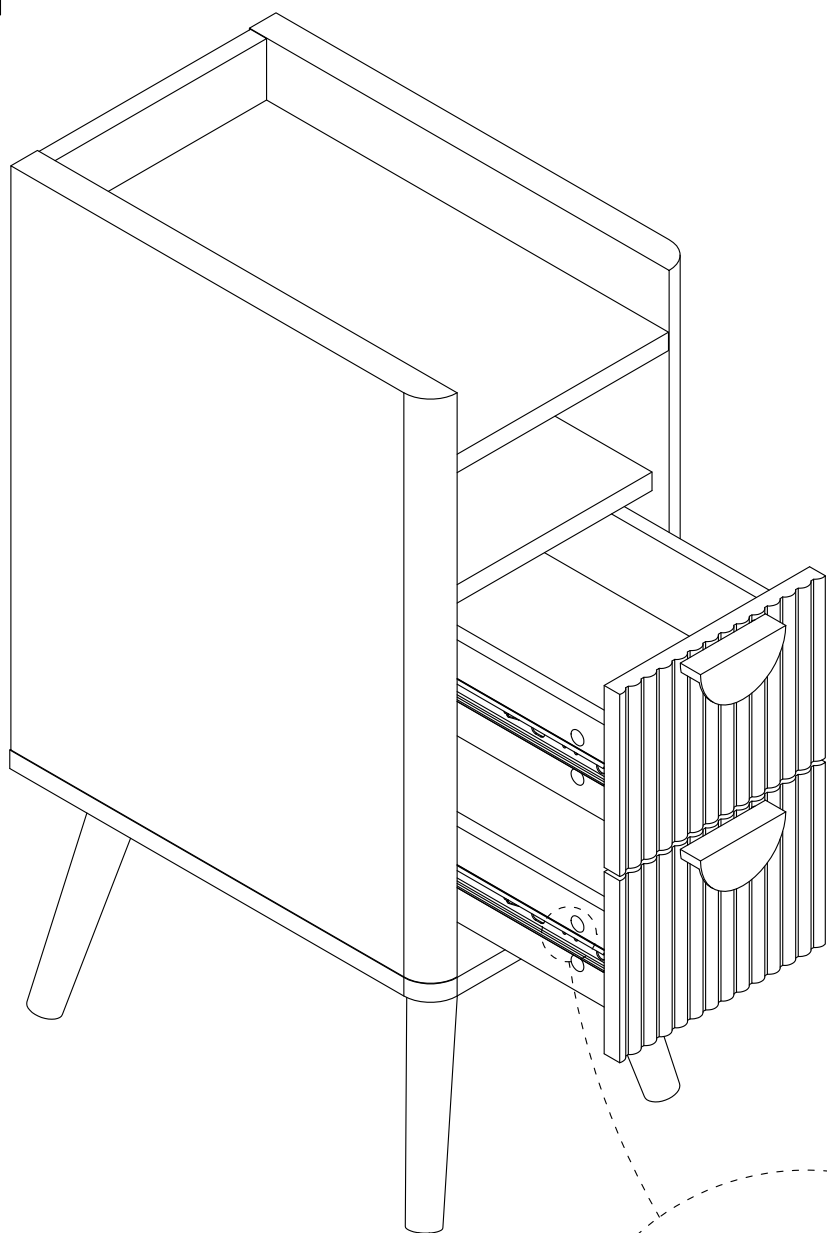

H	X4
	
M4x10mm	