







**ASSEMBLY INSTRUCTIONS / INSTRUCTIONS
D'ASSEMBLAGE / INSTRUCTIVO DEARMADO**



NOTES ON ASSEMBLY / NOTES POUR L'ASSEMBLAGE / NOTAS SOBRE EL ENSAMBLE

- To ensure ease of assembly read all instructions before assembly and follow step by step illustrations.
- Keep instructions for future use.
- Adult assembly required.  2 person required. 
- Due to the present of small parts during assembly, keep out of reach of children until assembly is complete.

- Pour assurer l'assemblage facile veuillez lire toutes les instructions avant l'assemblage et veuillez suivre les illustrations pour chaque etapes.
- Veuillez garder ces instructions pour l'usage ulterieur.
- Assemblage requis pas un adulte.  2 personnes requises. 
- Due a la presence de petite pieces durant l'assemblage, veuillez garder hors de porter des enfants jusqu'a ce que l'assemblage soit completer.

- Para garantizar la facilidad de ensamble lea las instrucciones antes de iniciar y siga paso a paso las ilustraciones.
- Guarde las instrucciones para futuras referencias.
- El ensamble requiere de un adulto.  2 personas requeridas. 
- Debido a que hay piezas pequeñas, mantenga fuera del alcance a los niños durante el ensamble, hasta que haya terminado.

MAINTENANCE TIPS / CONSEILS D'ENTRETIEN / CONSEJOS DE MANUTENIMIENTO

- Never let liquids or damp cloths sit on this furniture.
- Never use chemical cleaning products. They can damage the finish. For cleaning, use only a slightly damp cloth and wipe dry.
- To avoid dulling of the finish, do not place furniture in direct sunlight.
- Do not put plastic or rubber rings under appliances. Use cloth of felt protectors.
- To clean, use a soft or slightly damp cloth, then wipe with a clean, dry cloth.

- Ne jamais laisser de liquide ou linge humide sur le meuble.
- Ne jamais utiliser de nettoyeurs à base de produits chimiques, cela va endommager le fini. Utiliser seulement un linge légèrement humide.
- Ne pas placer le meuble directement au soleil pour prévenir le ternissement.
- Évitez de déposer des appareils avec des rondelles de plastique ou de caoutchouc. Utilisez un protecteur en tissu ou en feutre.
- Pour nettoyer, utilisez un linge doux ou légèrement humecté. Essuyez par la suite avec un linge propre et sec.

- Nunca deje un líquido o un trapo húmedo sobre el mueble.
- Nunca utilice limpiadores a base de químicos, estos dañaran le acabado. Use sólo un paño húmedo.
- No esponga el mueble directamente al sol para prevenir empañamiento.
- Evite apoyar aparatos con redondeles de plástico o de goma. Utilizar un protector de tela o de fieltro.
- Para limpiar, utilice un trapo suave o ligeramente humedecido. Seque luego con un trapo limpio y seco.

WARNING **AVERTISSEMENT / ADVERTENCIA**

Please use your furniture correctly and safely. Improper use can cause safety hazards, or damage to your furniture or household items.

- Follow the assembly steps in order. Do not skip any steps.
- Be sure to check all packing materials carefully for small parts may have come loose inside the carton during shipment. If parts are missing, contact the retailer from which you purchased the product to obtain any missing parts. **DO NOT USE SUBSTITUTE PARTS.**
- Periodically check to ensure that all connectors (bolts, screws, etc.) are tight.
- Keep the instruction for future reference.
- Do not stand on tables, including but not limited to, end table, coffee tables, and dinner tables, as tables are not to support the weight of a person.
- Where assembly instructions state that the assembly requires two or more people, do not attempt by yourself as there is a risk of injury.

Prrière d'utiliser le mobilier à bon escient et avec prudence. Une mauvaise utilisation peut être à l'origine de risques d'accident ou peut endommager le mobilier et les articles ménagers.

- Suivez l'ordre des étapes de montage. N'en sautez aucune.
- Assurez-vous de vérifier attentivement tous les matériaux d'emballage parce que les petites pièces peuvent se détacher à l'intérieur de la boîte lors de l'expédition. Faites l'inventaire attentif de toutes les pièces. Si une ou plusieurs pièces manquent, contactez votre revendeur pour obtenir les pièces en question. **N'UTILISEZ PAS DE PIÈCES DE SUBSTITUTION.**
- Vérifiez régulièrement que tous les connecteurs (boulons, vis, etc.) sont serrés.
- Gardez ces instructions pour pouvoir les consulter ultérieurement.
- Ne vous tenez pas sur les tables, ce qui comprend mais pas uniquement, les tables d'extrémité, les tables basses, les tables à dîner, car elles ne sont pas destinées à supporter le poids des personnes.
- Lorsque les instructions de montage mentionnent que l'installation nécessite deux personnes ou plus, n'essayez pas de monter vous-même le produit, car vous risqueriez de vous blesser.

Por favor use el mobiliario correcta y seguramente. El mal uso puede causar riesgos de seguridad o daño a las unidades o artículos domésticos.

- Siga las pasos de ensamble en orden. No solte ningún paso.
- Asegúrese de comprobar con cuidado todos los materiales de embalaje en busca de piezas que se hayan podido desprenderse dentro del cartón durante el envío. Revise la lista de partes. Si faltan partes, comuníquese con el surtidor del cual usted compró el producto para obtener las partes que le faltan. **NO USE PARTES SUBSTITUTAS.**
- Periódicamente revise para asegurarse que todos los conectores (pernos, tornillos, etc.) estén bien apretados.
- Guarde las instrucciones para referencia futura.
- No se pare en las mesas, incluyendo pero sin límite a, mesas laterales, mesas de centro, mesas de comedor, ya que estas mesas no están diseñadas para soportar el peso de una persona.
- Si las instrucciones dicen que se debe usar dos o más personas no trate de armarlo solo, ya que corre el riesgo de lastimarse.

THINGS TO REMEMBER FOR ASSEMBLY

CHOSSES À SE SOUVENIR POUR UNE ASSEMBLEE

COSAS PARA RECORDAR EN UNA ASAMBLEA

MINIFIX BOLT BOULON MINIFIX PERNO MINIFIX

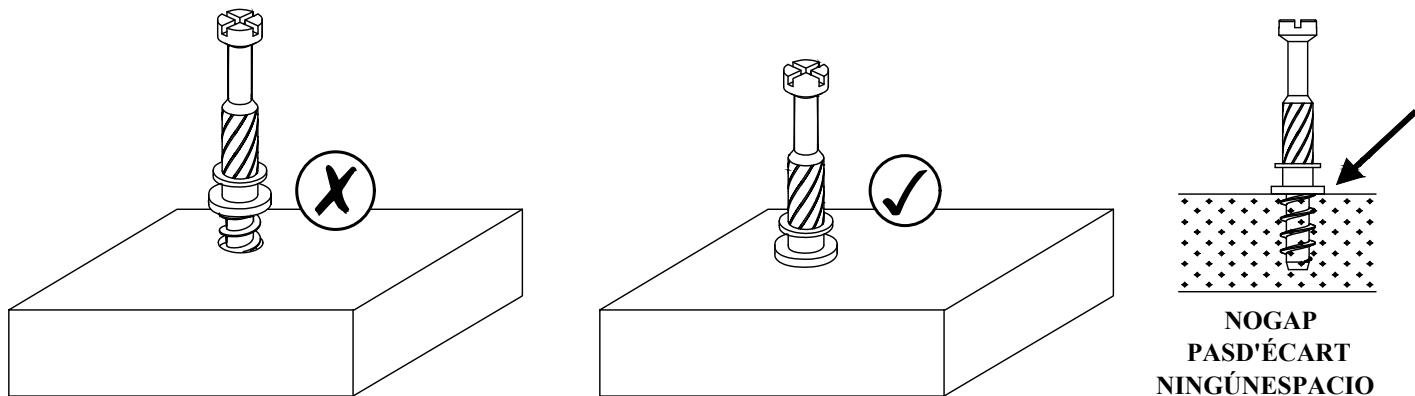

MINIFIX CAM CAMÉRA MINIFIX CÁMARA MINIFIX

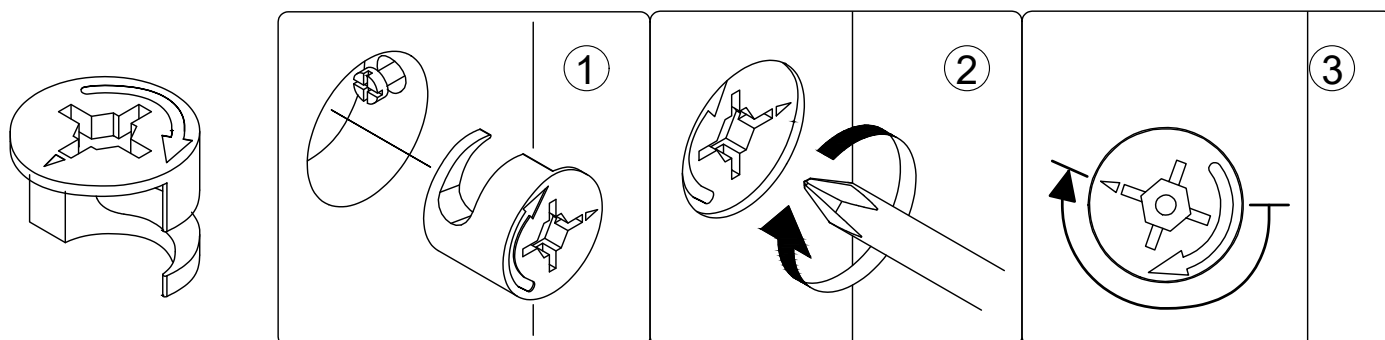



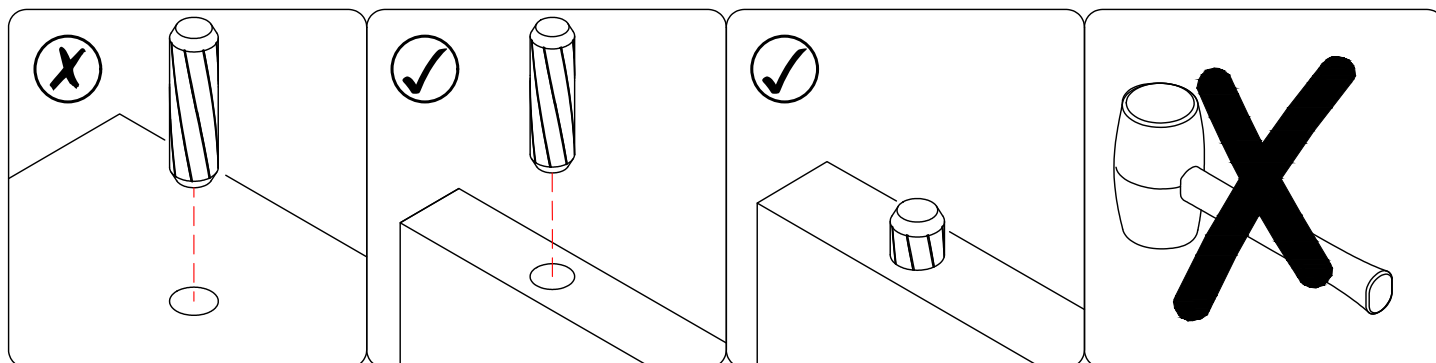



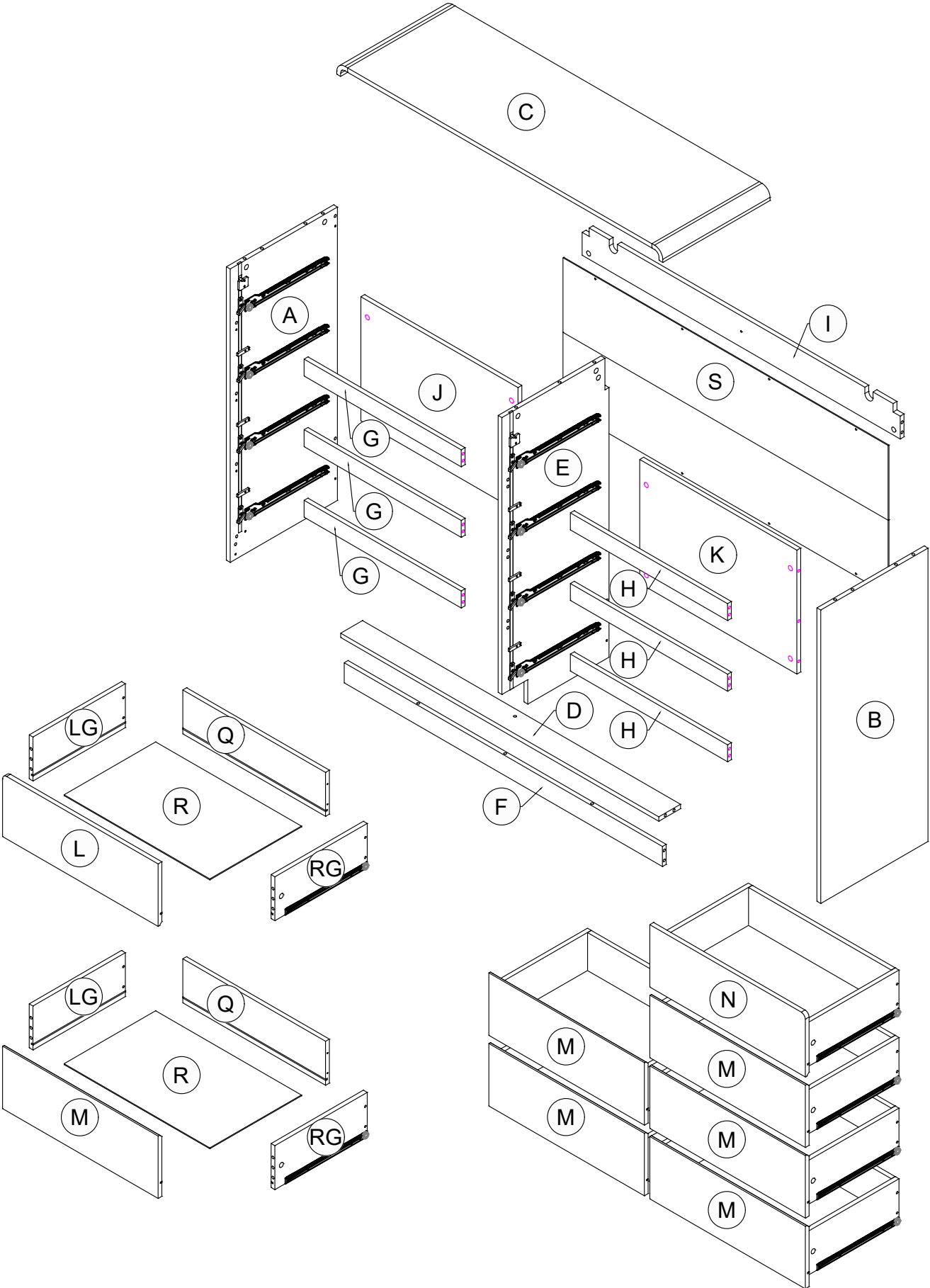







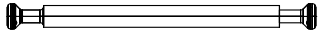
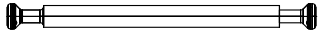



WOOD DOWEL CHEVILLE BOIS PASADOR DE MADERA

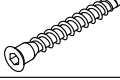
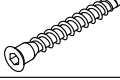
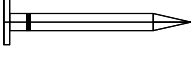
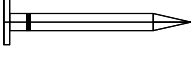
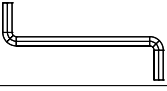
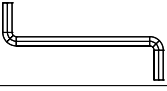

PARTS IDENTIFICATION
IDENTIFICATION DES PIÈCES
IDENTIFICACIÓN DE LAS PARTES

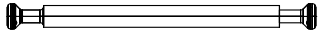



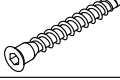
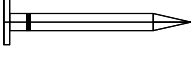
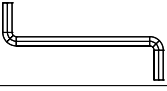





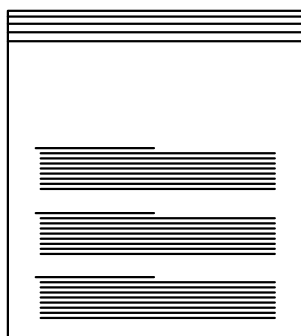



HARDWARE QUINCAILLERIE / HERRAJE

<table border="1" style="width: 100%; border-collapse: collapse;"> <tr> <td style="text-align: center;">(A)</td> <td style="text-align: center;">Minifix Bolt</td> </tr> <tr> <td colspan="2" style="text-align: center;"></td> </tr> <tr> <td colspan="2" style="text-align: center;">45 units</td> </tr> </table>	(A)	Minifix Bolt			45 units		<table border="1" style="width: 100%; border-collapse: collapse;"> <tr> <td style="text-align: center;">(B)</td> <td style="text-align: center;">Minifix Cam</td> </tr> <tr> <td colspan="2" style="text-align: center;"></td> </tr> <tr> <td colspan="2" style="text-align: center;">51 units</td> </tr> </table>	(B)	Minifix Cam			51 units		<table border="1" style="width: 100%; border-collapse: collapse;"> <tr> <td style="text-align: center;">(C)</td> <td style="text-align: center;">Minifix Double Bolt</td> </tr> <tr> <td colspan="2" style="text-align: center;"></td> </tr> <tr> <td colspan="2" style="text-align: center;">3 units</td> </tr> </table>	(C)	Minifix Double Bolt			3 units		<table border="1" style="width: 100%; border-collapse: collapse;"> <tr> <td style="text-align: center;">(D)</td> <td style="text-align: center;">Dowel M8 x 30mm</td> </tr> <tr> <td colspan="2" style="text-align: center;"></td> </tr> <tr> <td colspan="2" style="text-align: center;">54 units</td> </tr> </table>	(D)	Dowel M8 x 30mm			54 units		<table border="1" style="width: 100%; border-collapse: collapse;"> <tr> <td style="text-align: center;">(E)</td> <td style="text-align: center;">Dowel M8 x 50mm</td> </tr> <tr> <td colspan="2" style="text-align: center;"></td> </tr> <tr> <td colspan="2" style="text-align: center;">3 units</td> </tr> </table>	(E)	Dowel M8 x 50mm			3 units		<table border="1" style="width: 100%; border-collapse: collapse;"> <tr> <td style="text-align: center;">(F)</td> <td style="text-align: center;">Screw M3.5 x 15mm</td> </tr> <tr> <td colspan="2" style="text-align: center;"></td> </tr> <tr> <td colspan="2" style="text-align: center;">8 units</td> </tr> </table>	(F)	Screw M3.5 x 15mm			8 units		<table border="1" style="width: 100%; border-collapse: collapse;"> <tr> <td style="text-align: center;">(G)</td> <td style="text-align: center;">Screw M4 X 38mm</td> </tr> <tr> <td colspan="2" style="text-align: center;"></td> </tr> <tr> <td colspan="2" style="text-align: center;">32 units</td> </tr> </table>	(G)	Screw M4 X 38mm			32 units		<table border="1" style="width: 100%; border-collapse: collapse;"> <tr> <td style="text-align: center;">(H)</td> <td style="text-align: center;">Unitar Screw M6.3 x 40mm</td> </tr> <tr> <td colspan="2" style="text-align: center;"></td> </tr> <tr> <td colspan="2" style="text-align: center;">1 units</td> </tr> </table>	(H)	Unitar Screw M6.3 x 40mm			1 units		<table border="1" style="width: 100%; border-collapse: collapse;"> <tr> <td style="text-align: center;">(I)</td> <td style="text-align: center;">Nail</td> </tr> <tr> <td colspan="2" style="text-align: center;"></td> </tr> <tr> <td colspan="2" style="text-align: center;">6 units</td> </tr> </table>	(I)	Nail			6 units		<table border="1" style="width: 100%; border-collapse: collapse;"> <tr> <td style="text-align: center;">(J)</td> <td style="text-align: center;">Allen Key Z (M4)</td> </tr> <tr> <td colspan="2" style="text-align: center;"></td> </tr> <tr> <td colspan="2" style="text-align: center;">1 units</td> </tr> </table>	(J)	Allen Key Z (M4)			1 units	
(A)	Minifix Bolt																																																																				
																																																																					
45 units																																																																					
(B)	Minifix Cam																																																																				
																																																																					
51 units																																																																					
(C)	Minifix Double Bolt																																																																				
																																																																					
3 units																																																																					
(D)	Dowel M8 x 30mm																																																																				
																																																																					
54 units																																																																					
(E)	Dowel M8 x 50mm																																																																				
																																																																					
3 units																																																																					
(F)	Screw M3.5 x 15mm																																																																				
																																																																					
8 units																																																																					
(G)	Screw M4 X 38mm																																																																				
																																																																					
32 units																																																																					
(H)	Unitar Screw M6.3 x 40mm																																																																				
																																																																					
1 units																																																																					
(I)	Nail																																																																				
																																																																					
6 units																																																																					
(J)	Allen Key Z (M4)																																																																				
																																																																					
1 units																																																																					

- Hardware quantity may supplied more than it required. Please keep spares and tools for future use.
- La cantidad de hardware puede suministrarse más de lo requerido. Guarde los repuestos y las herramientas para uso futuro.
- La quantité de matériel peut fournir plus que nécessaire. Veuillez conserver les pièces de rechange et les outils pour une utilisation future.

FURNITURE TIPPING RESTRAINT SEGURO CONTRA VOLCADO DE MUEBLES DISPOSITIF DE SÉCURITÉ POUR MEUBLES



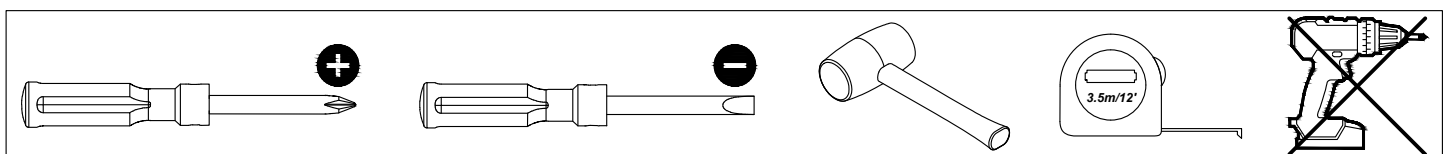

<table border="1" style="width: 100%; border-collapse: collapse;"> <tr> <td style="text-align: center;">(AA)</td> <td style="text-align: center;">Mounting L-Bracket</td> </tr> <tr> <td colspan="2" style="text-align: center;"></td> </tr> <tr> <td colspan="2" style="text-align: center;">2 units</td> </tr> </table>	(AA)	Mounting L-Bracket			2 units		<table border="1" style="width: 100%; border-collapse: collapse;"> <tr> <td style="text-align: center;">(BB)</td> <td style="text-align: center;">Washer M6 x 16mm</td> </tr> <tr> <td colspan="2" style="text-align: center;"></td> </tr> <tr> <td colspan="2" style="text-align: center;">2 units</td> </tr> </table>	(BB)	Washer M6 x 16mm			2 units		<table border="1" style="width: 100%; border-collapse: collapse;"> <tr> <td style="text-align: center;">(CC)</td> <td style="text-align: center;">Screw #10 x 12mm</td> </tr> <tr> <td colspan="2" style="text-align: center;"></td> </tr> <tr> <td colspan="2" style="text-align: center;">2 units</td> </tr> </table>	(CC)	Screw #10 x 12mm			2 units		<table border="1" style="width: 100%; border-collapse: collapse;"> <tr> <td style="text-align: center;">(DD)</td> <td style="text-align: center;">Screw M4 x 38mm</td> </tr> <tr> <td colspan="2" style="text-align: center;"></td> </tr> <tr> <td colspan="2" style="text-align: center;">2 units</td> </tr> </table>	(DD)	Screw M4 x 38mm			2 units	
(AA)	Mounting L-Bracket																										
																											
2 units																											
(BB)	Washer M6 x 16mm																										
																											
2 units																											
(CC)	Screw #10 x 12mm																										
																											
2 units																											
(DD)	Screw M4 x 38mm																										
																											
2 units																											

TOOLS NOT INCLUDED OUTILS PAS INCLUS / HERRAMIENTAS NO INCLUIDAS



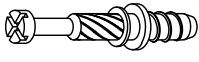

STEP 1

Layout parts on soft surface.

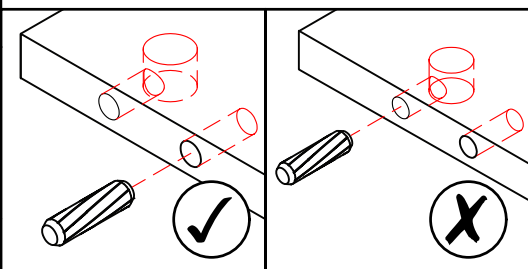
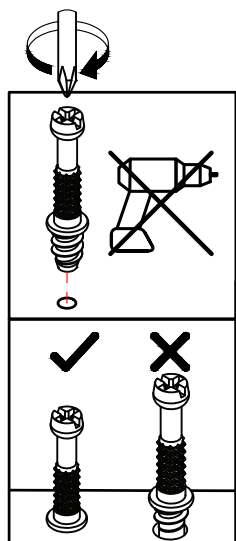
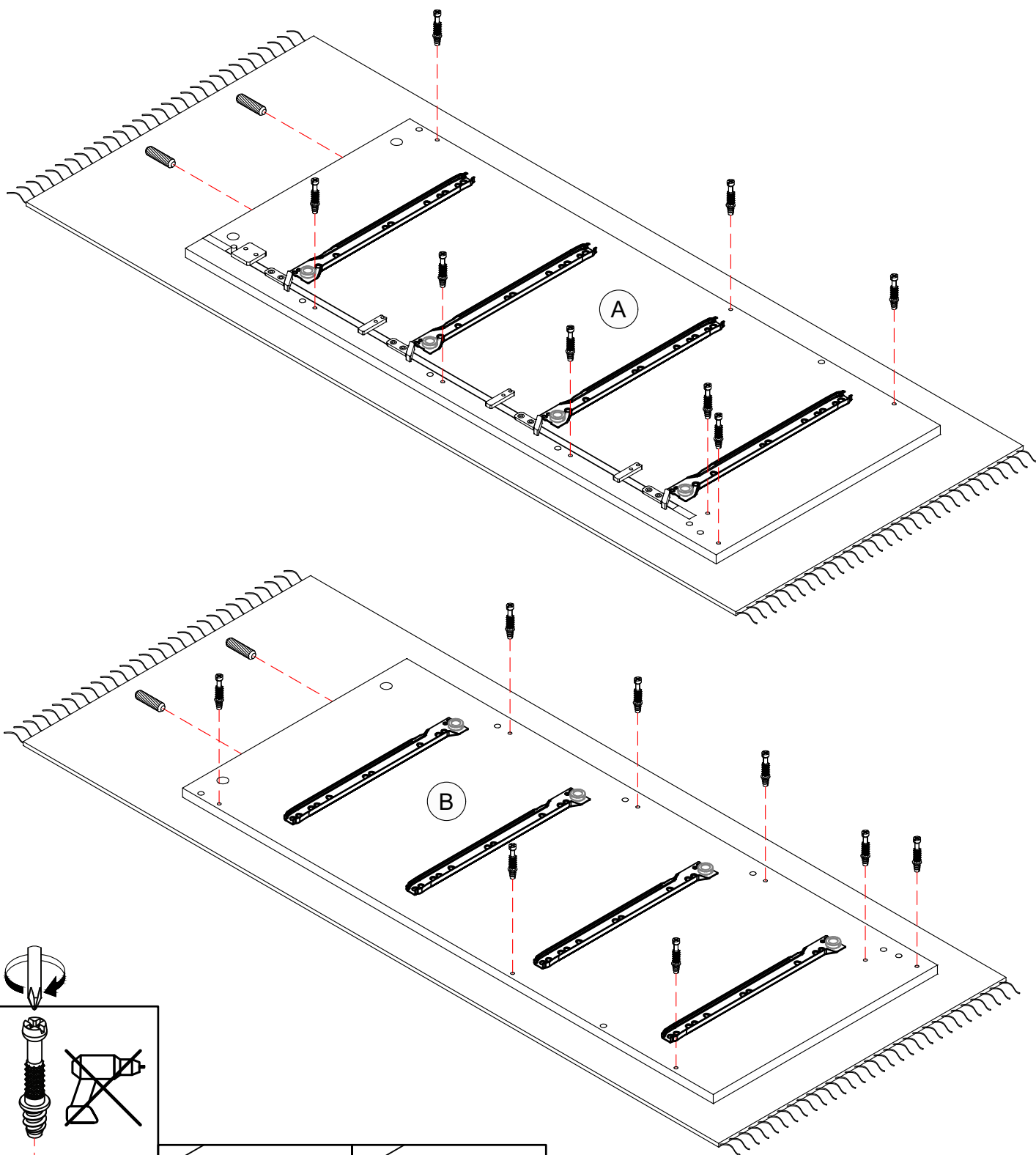
	
A x 16	D x 4



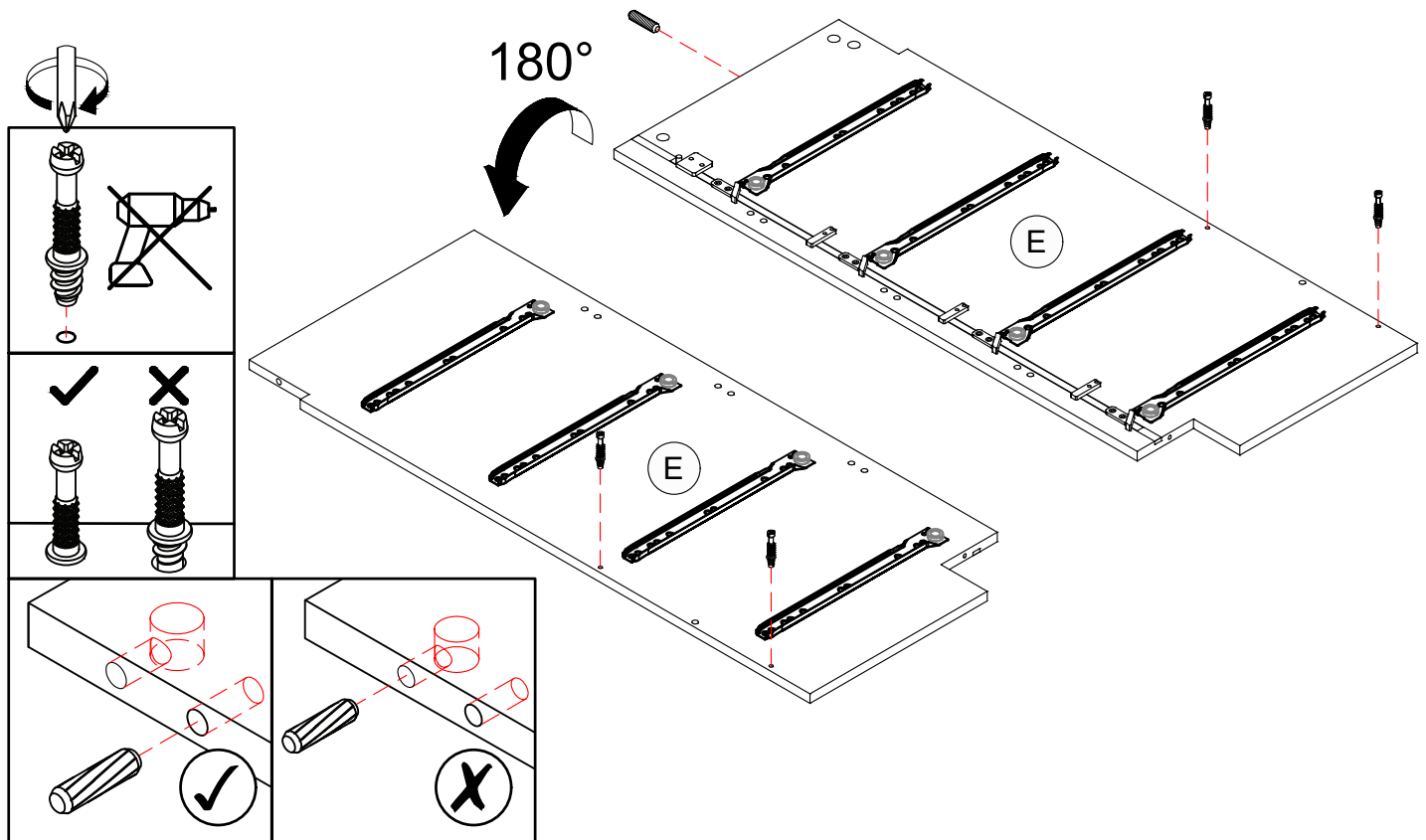

STEP 2

	
A x 4	D x 1



STEP 3

	
A x 1	D x 6

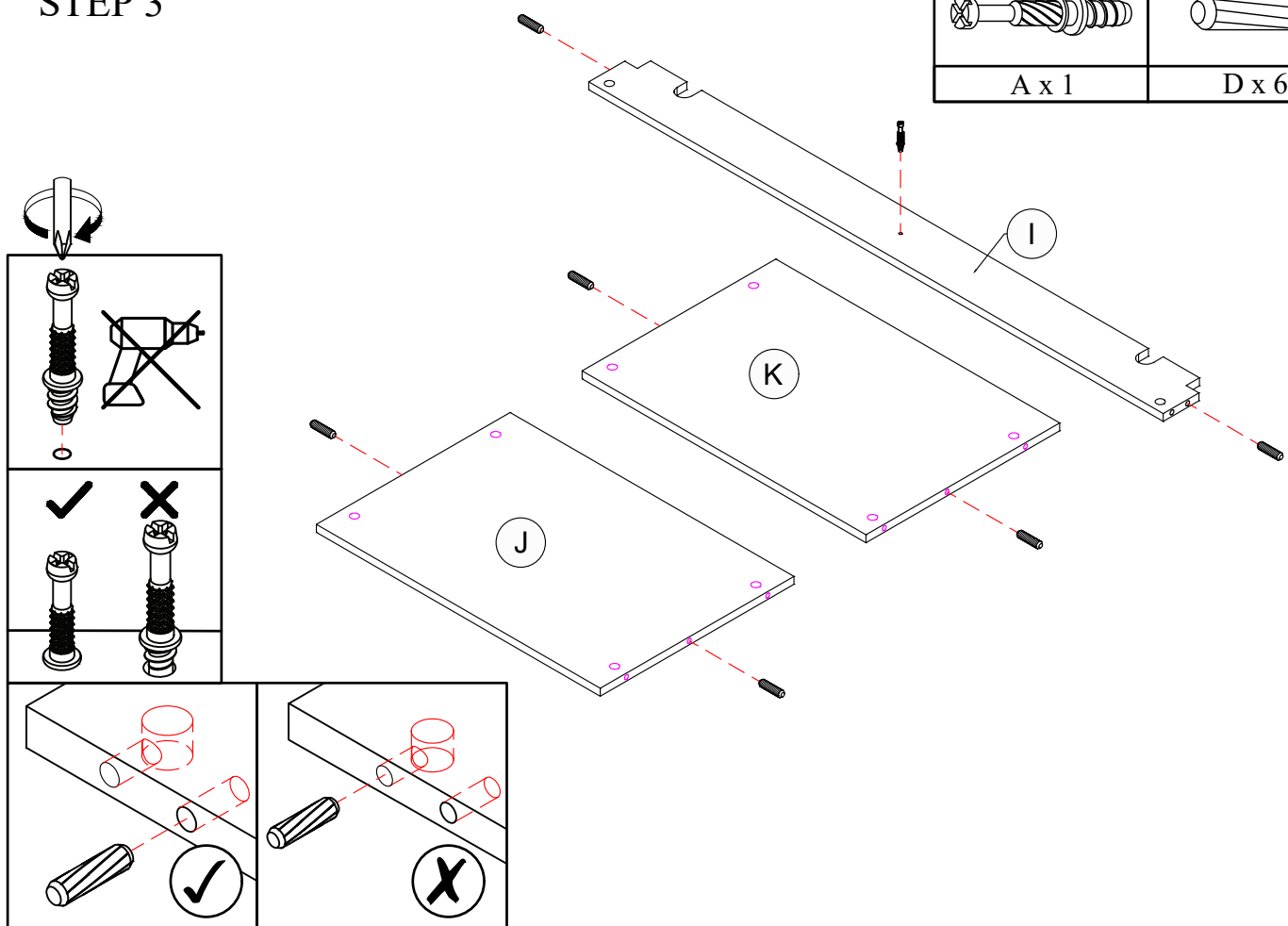

STEP 4

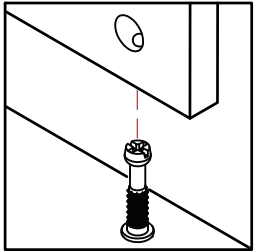
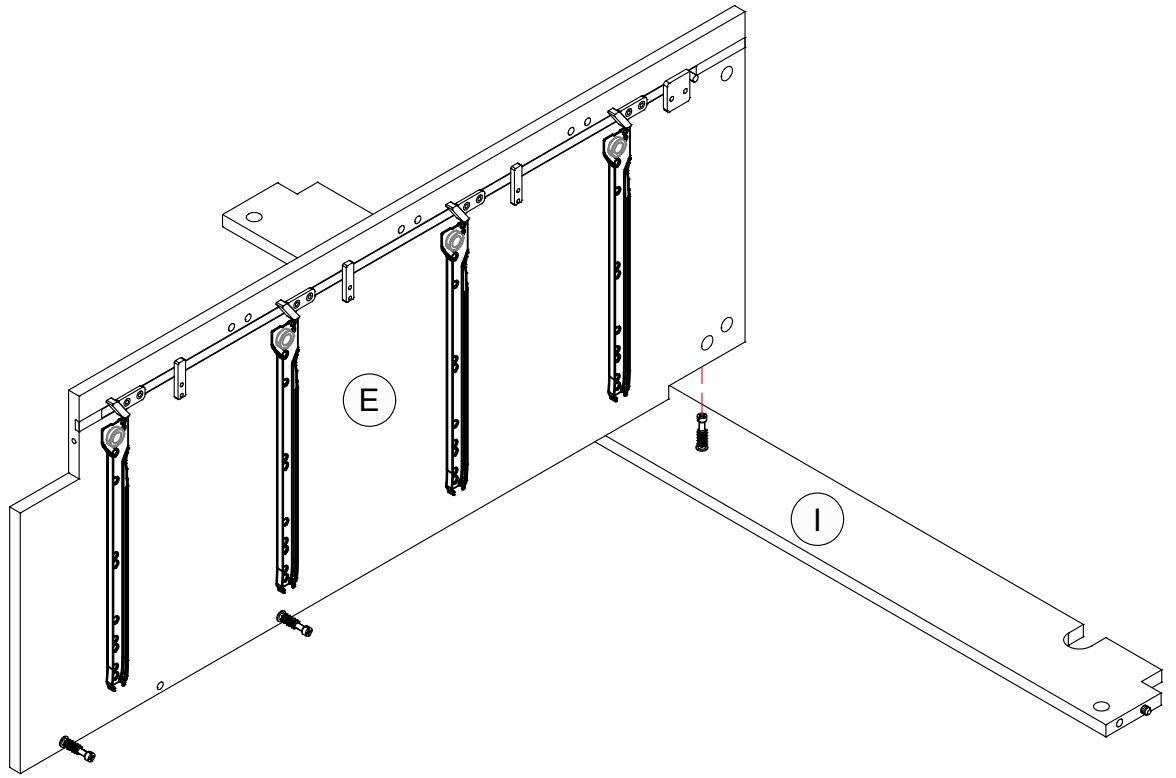

STEP 5

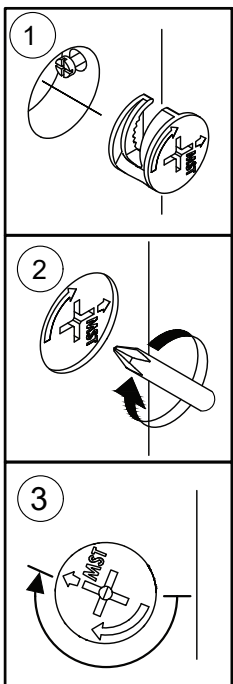
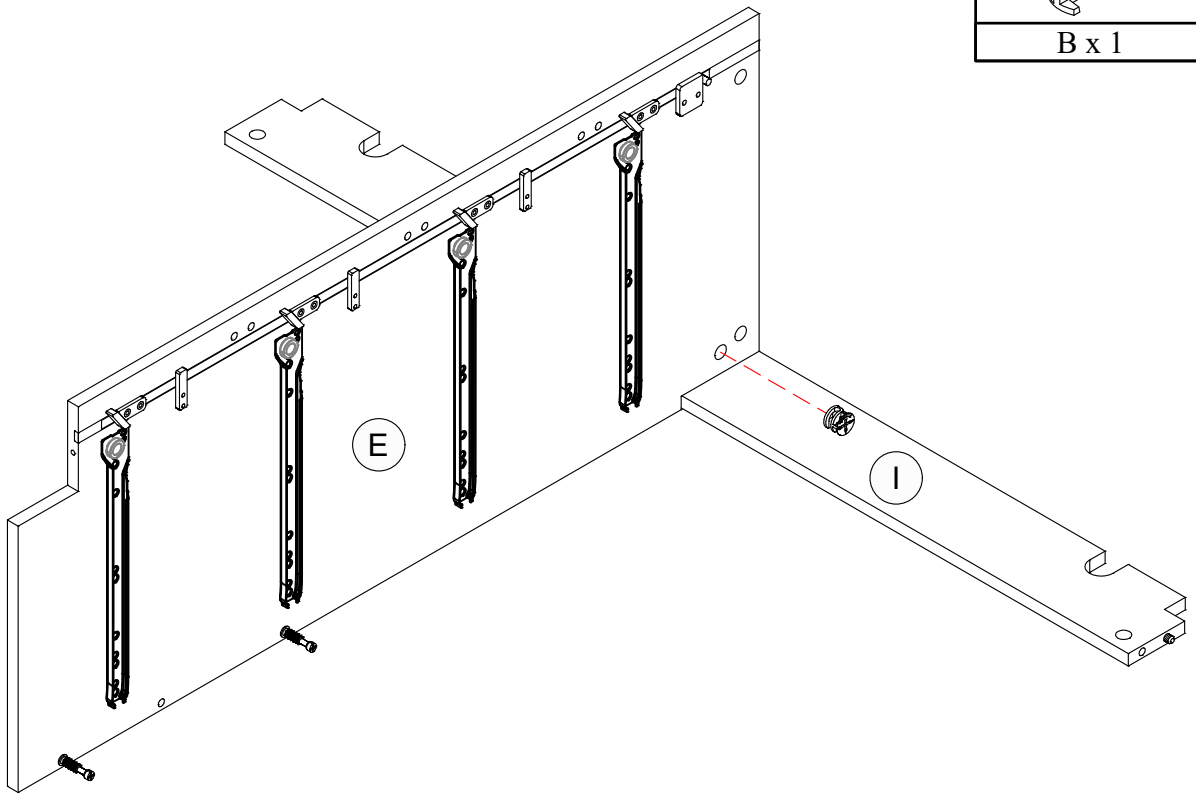
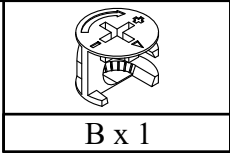

STEP 6

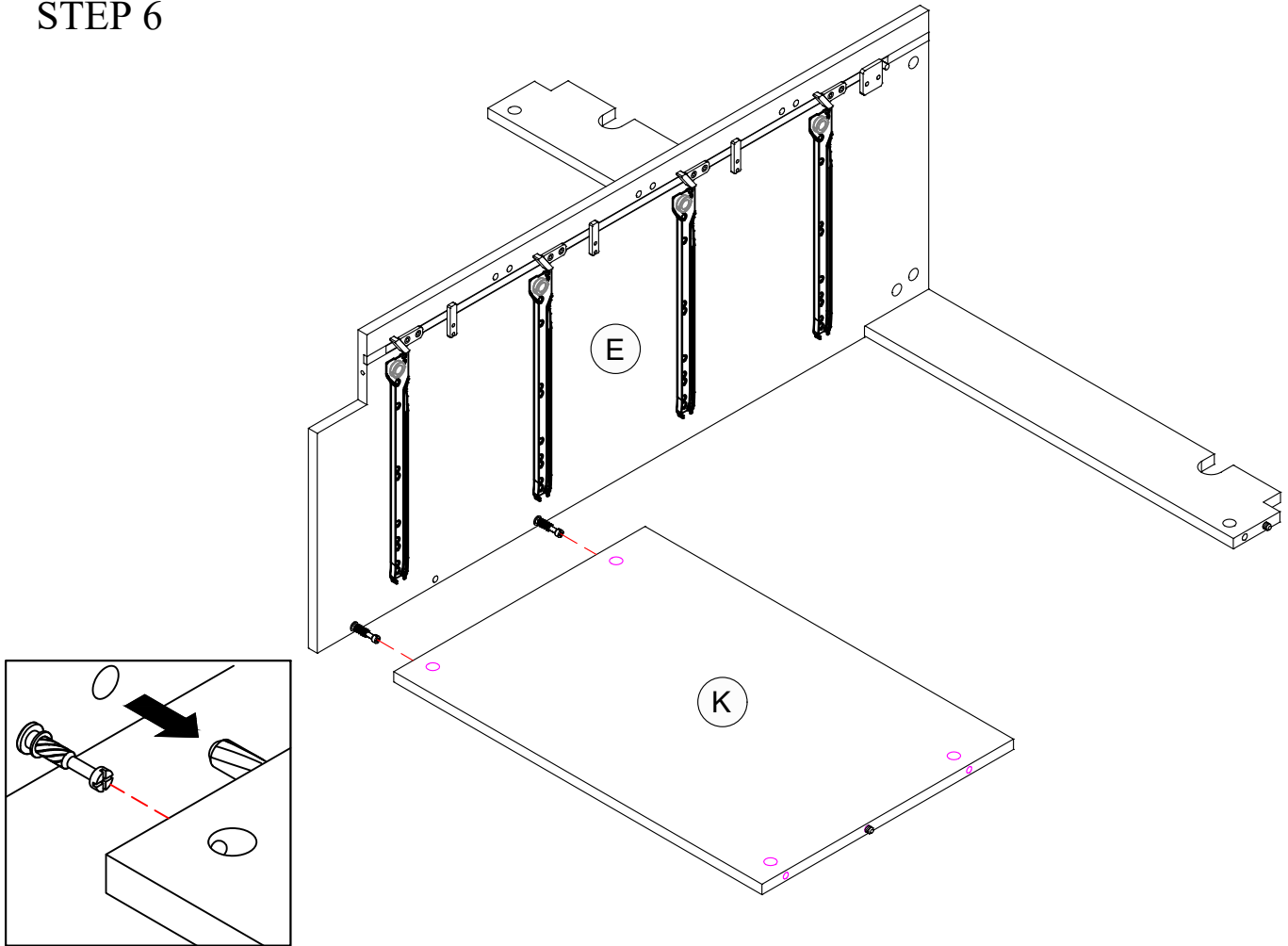

STEP 7

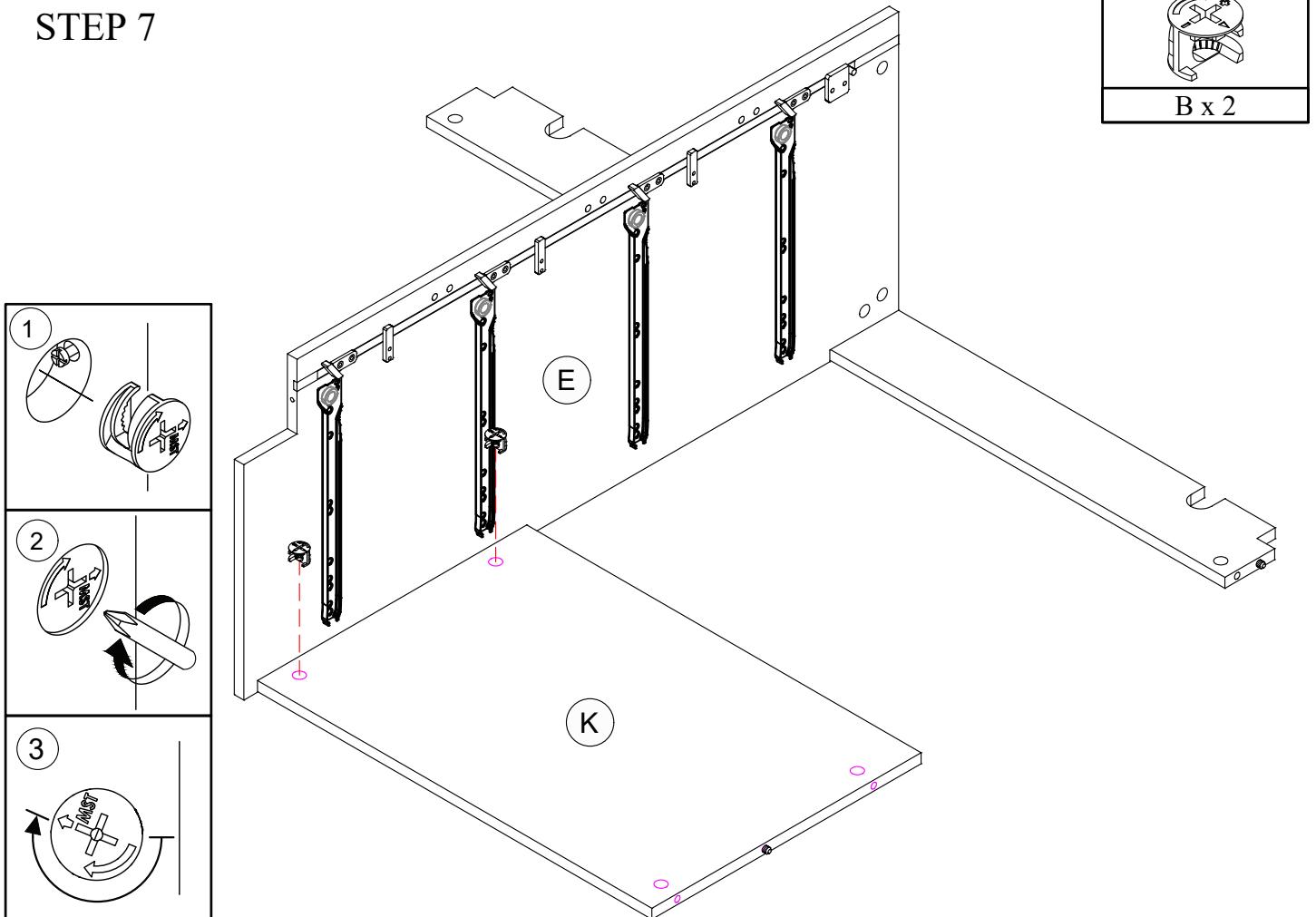

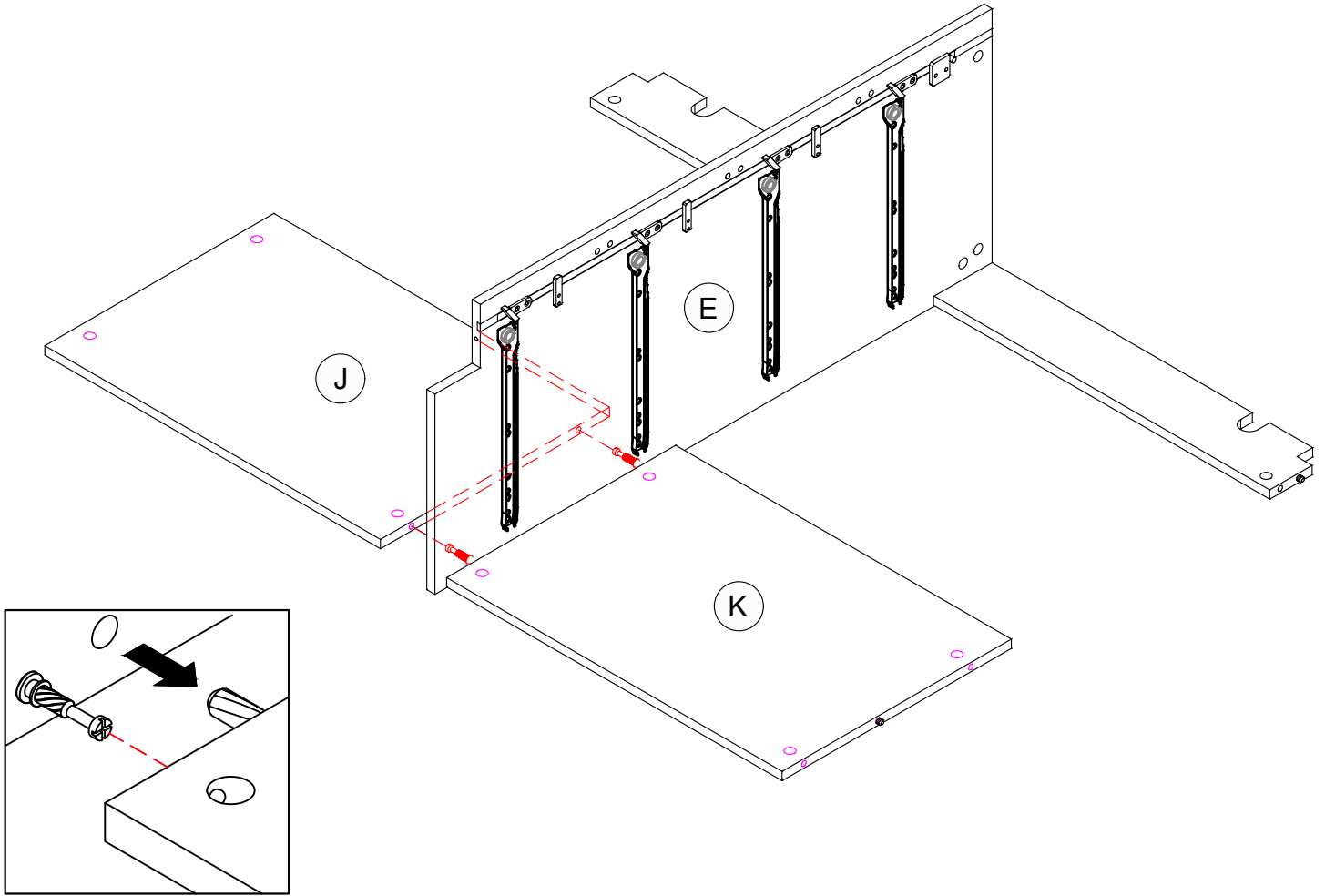

STEP 8

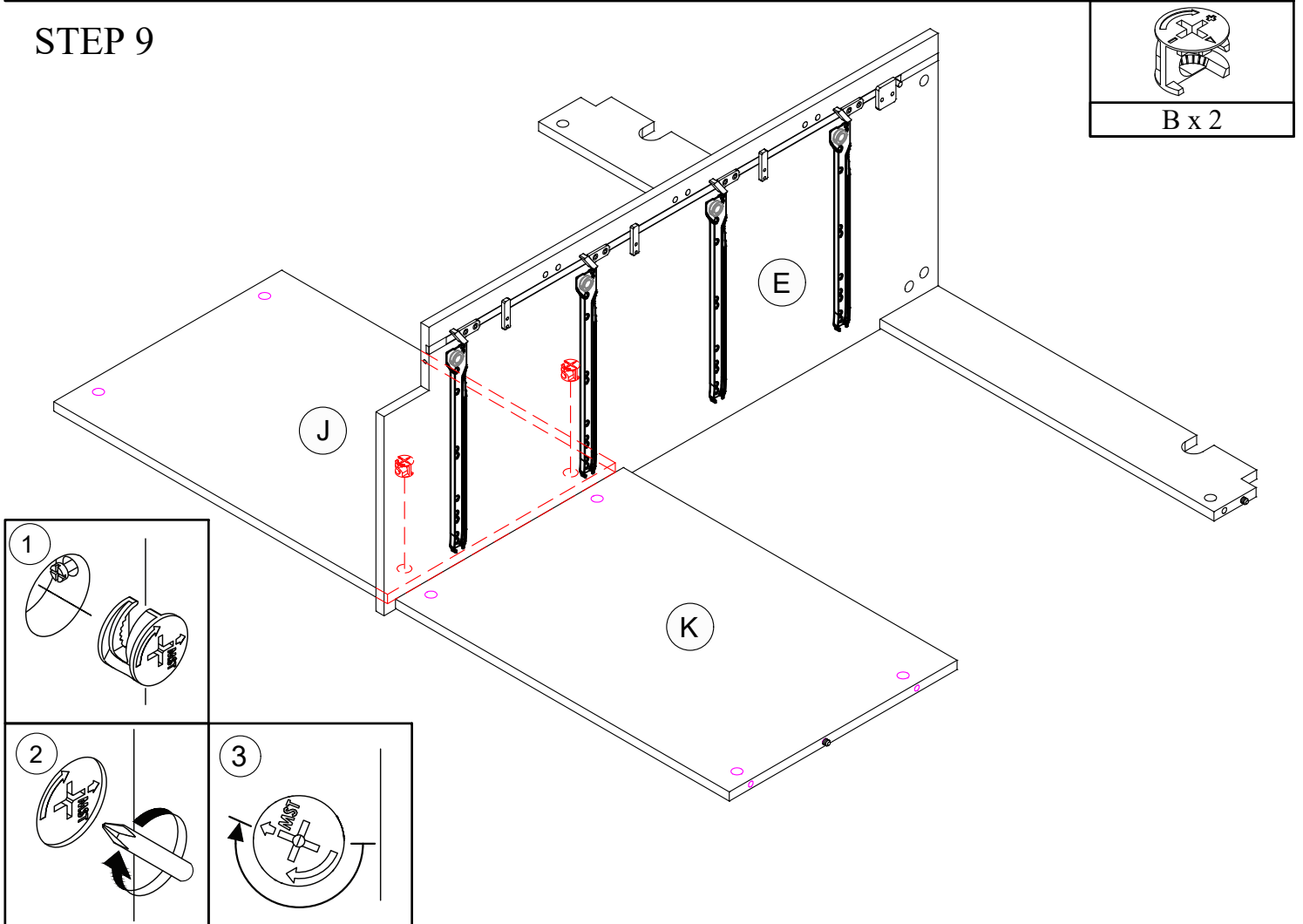

STEP 9



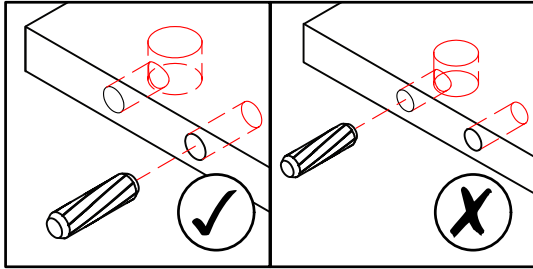
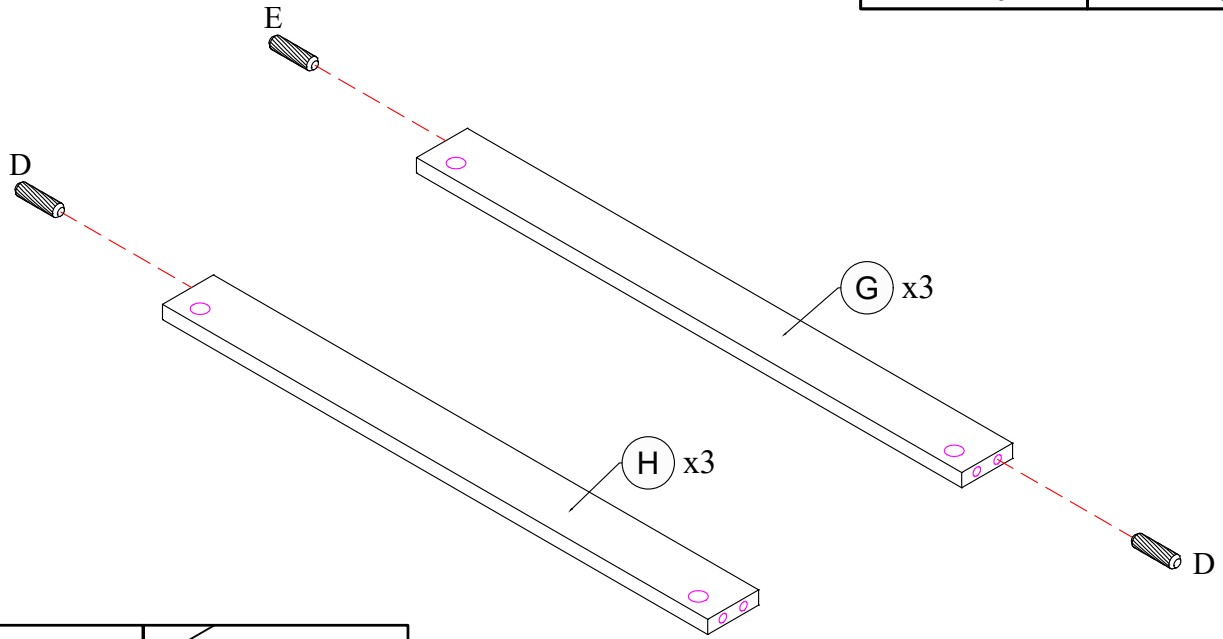

STEP 10

	
D x 6	E x 3



(x3)

STEP 11

	
A x 2	D x 5

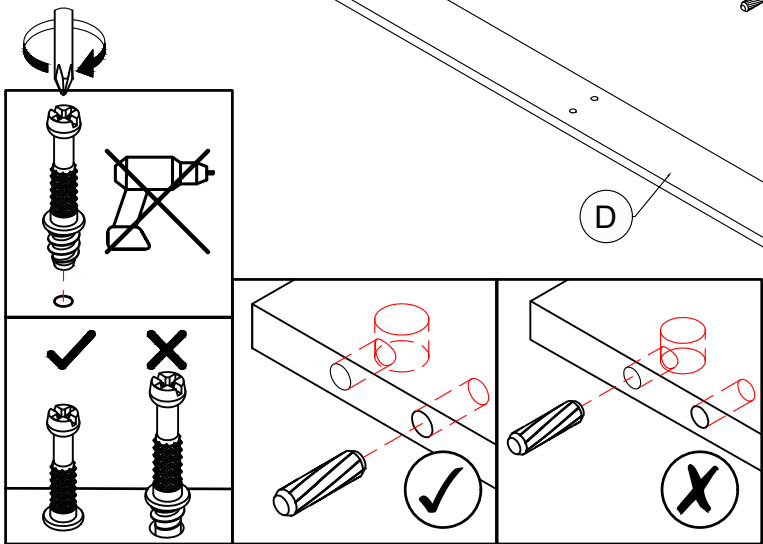
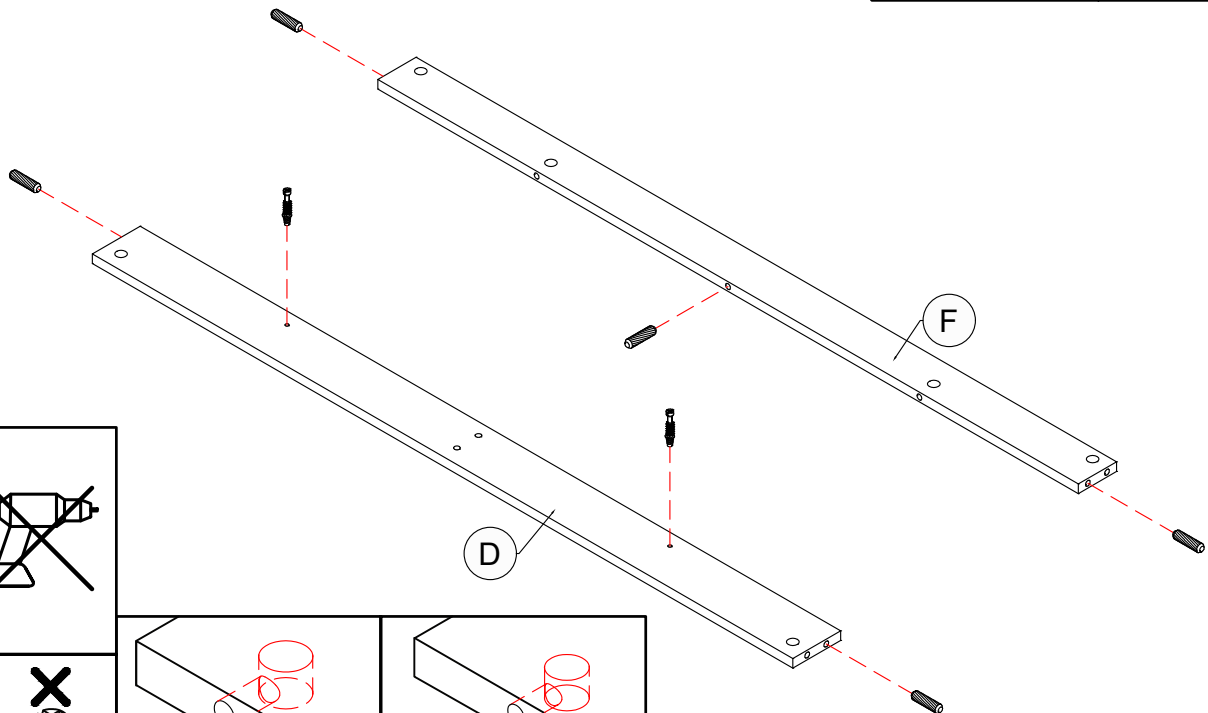

STEP 12

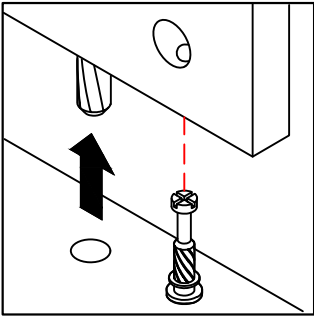
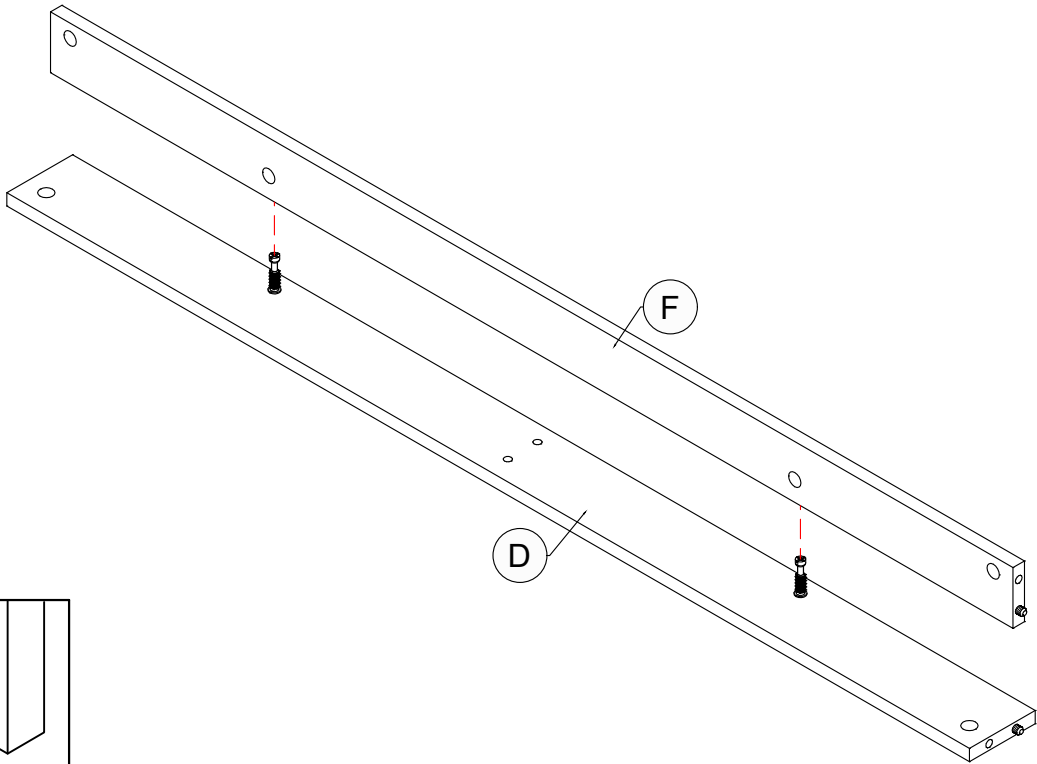

STEP 13

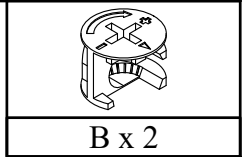

B x 2

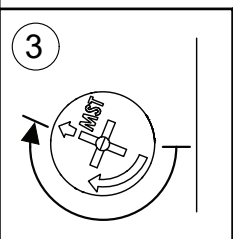
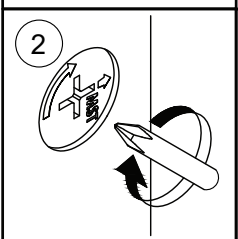
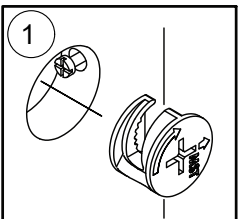
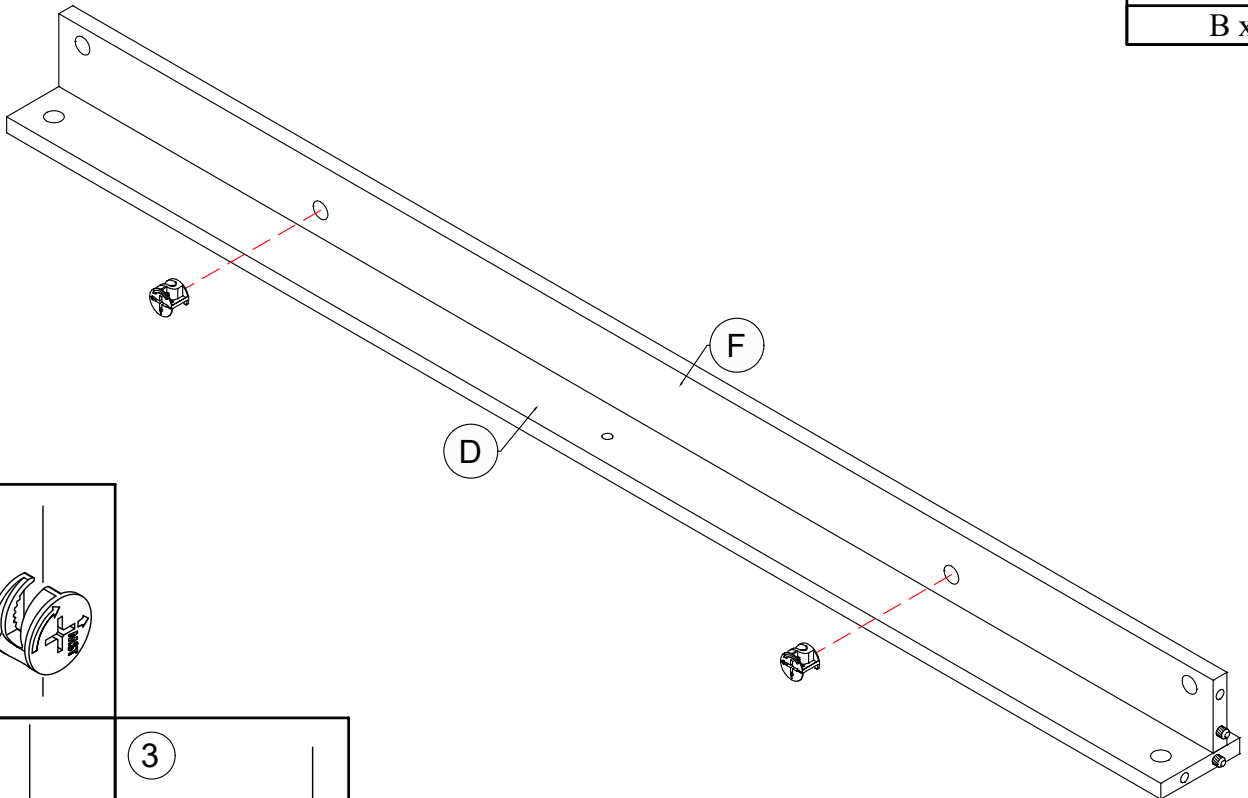

STEP 14

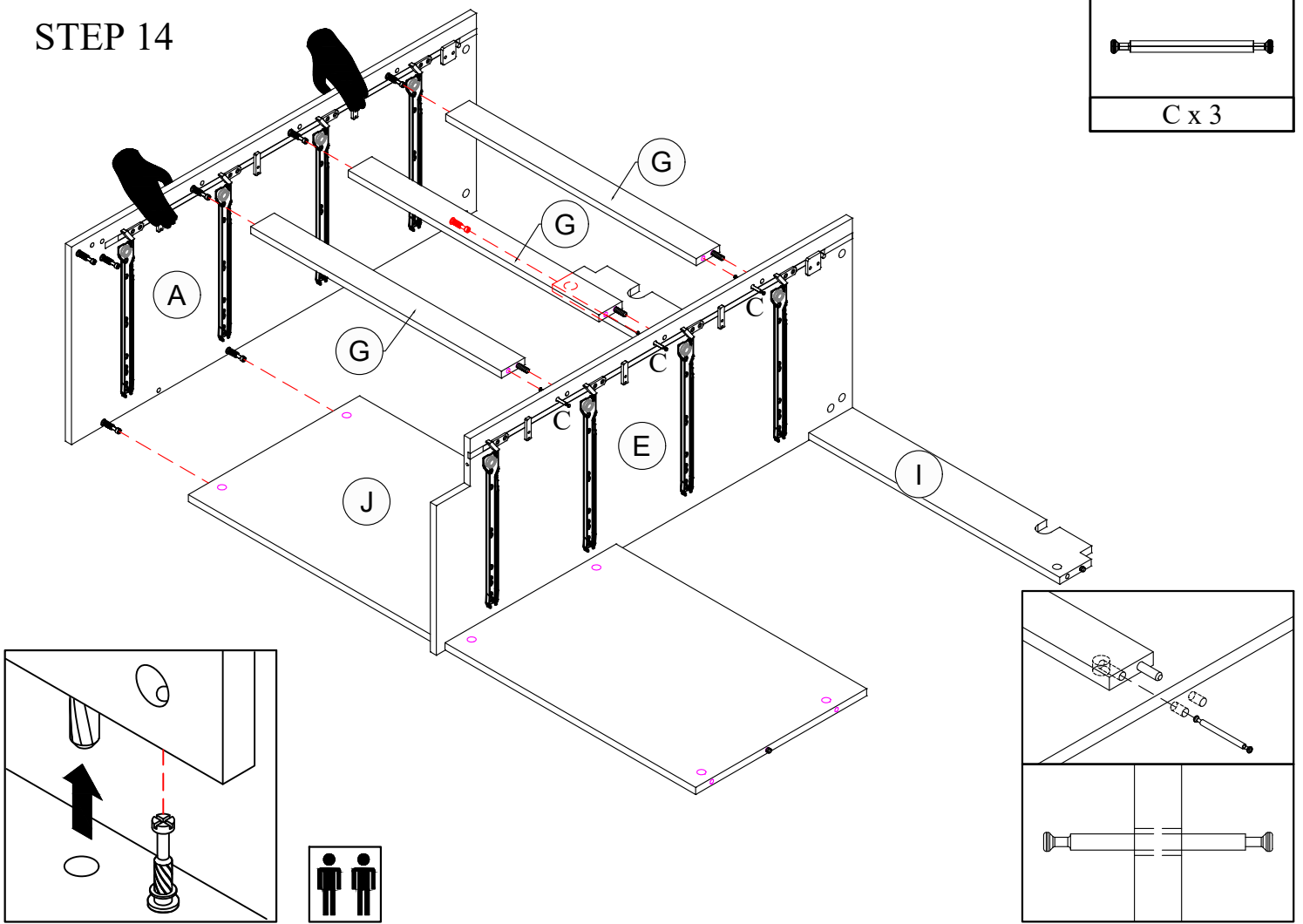

STEP 15

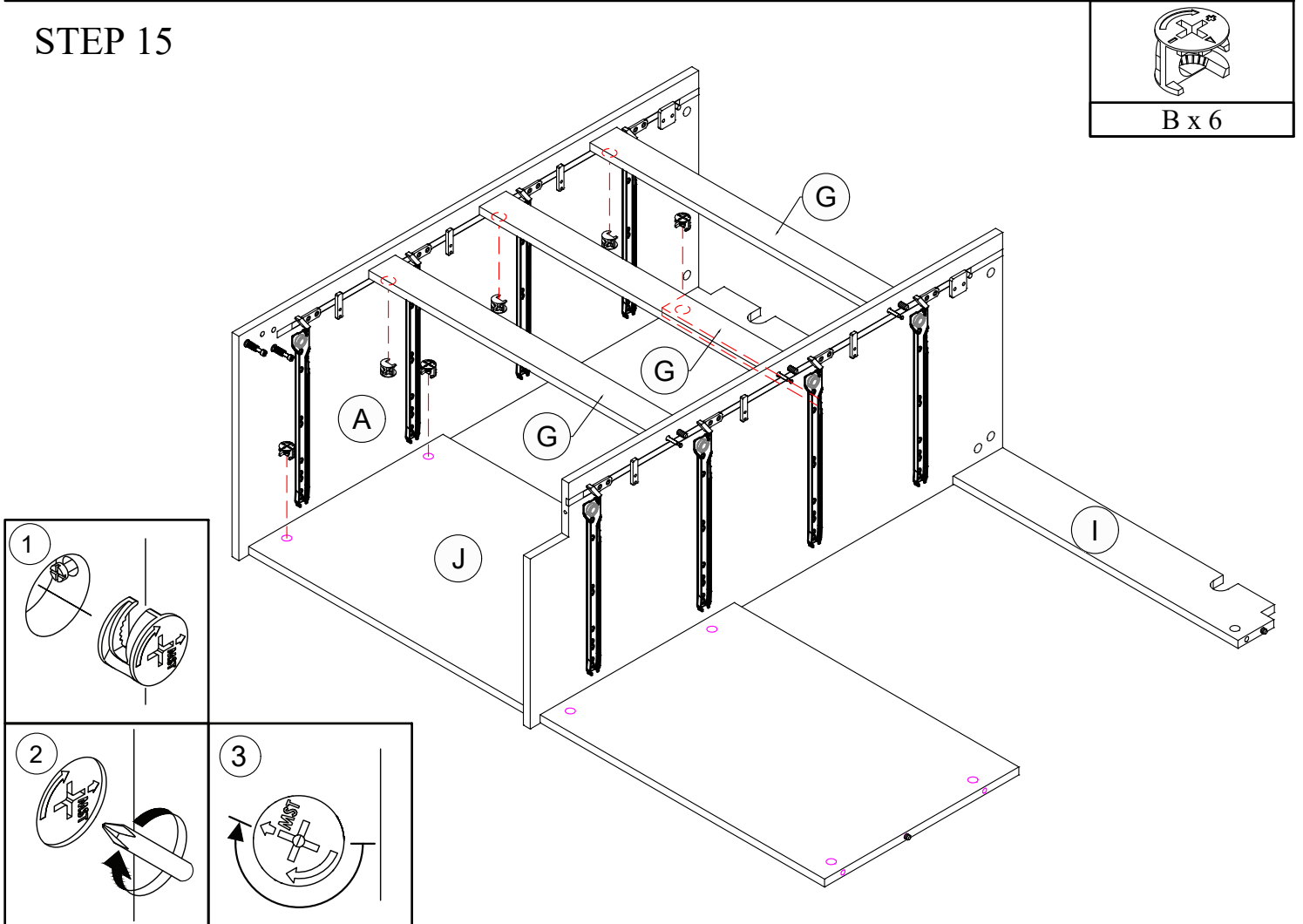

STEP 16

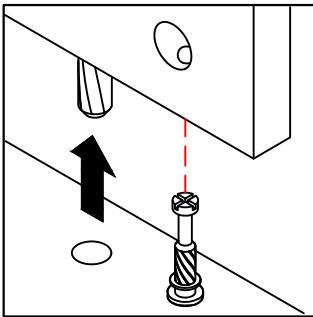
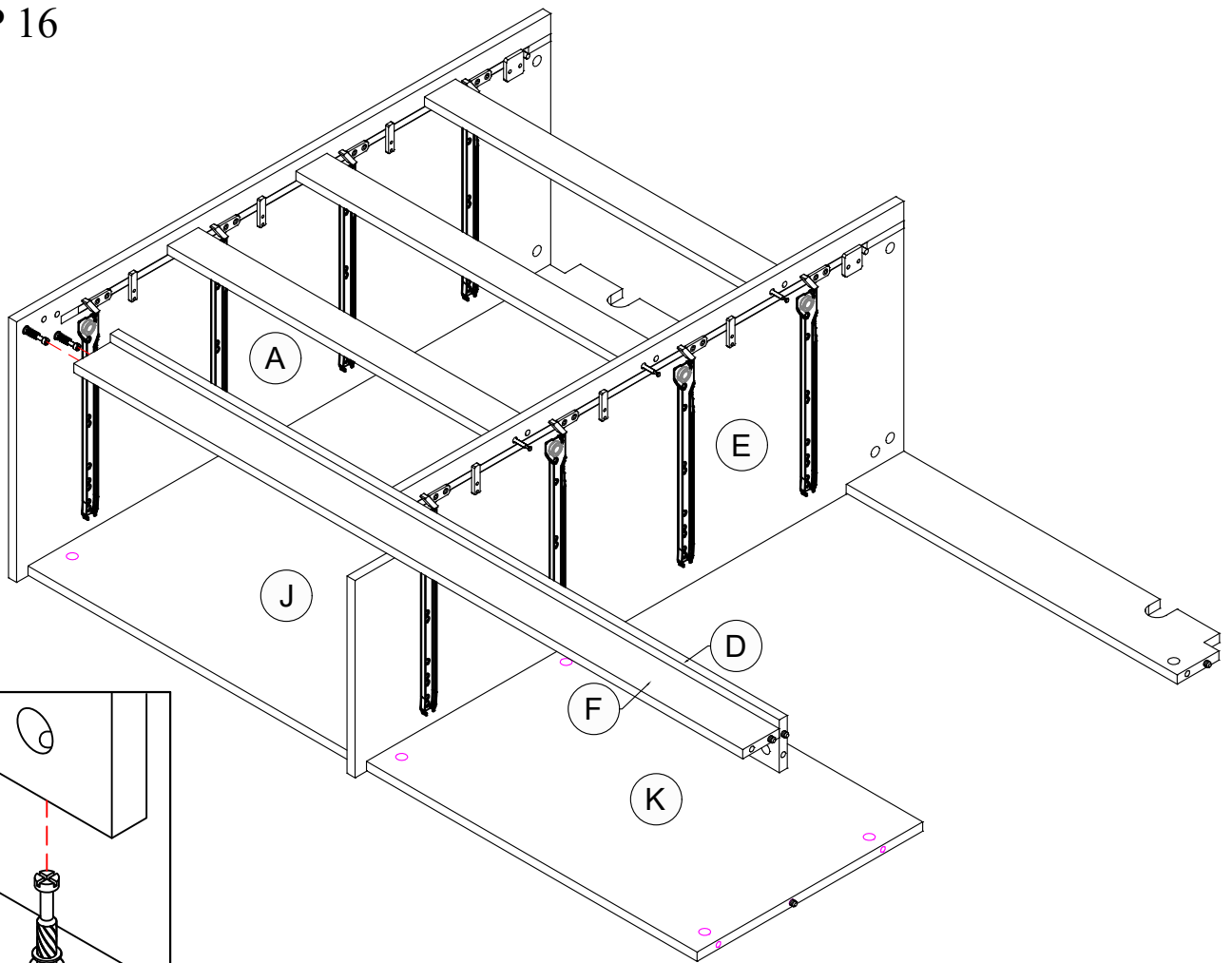

STEP 17

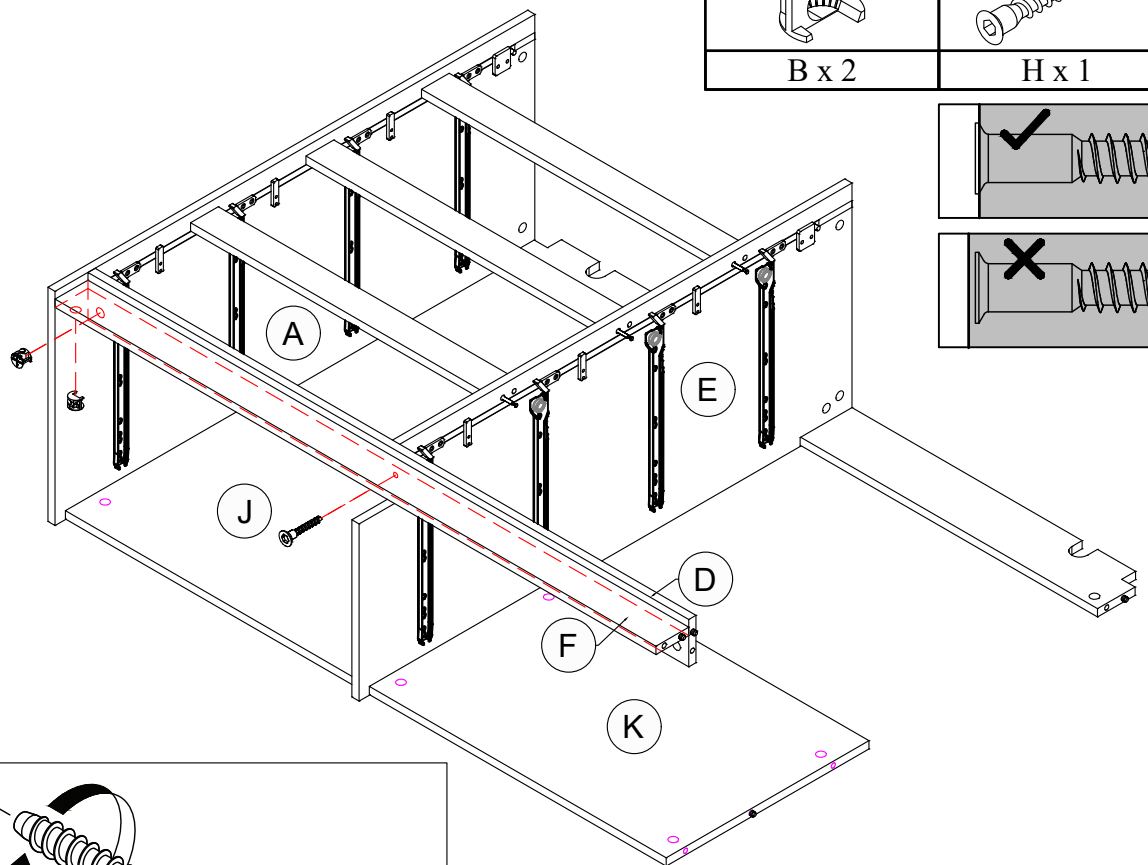

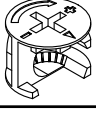
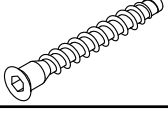
	
B x 2	H x 1

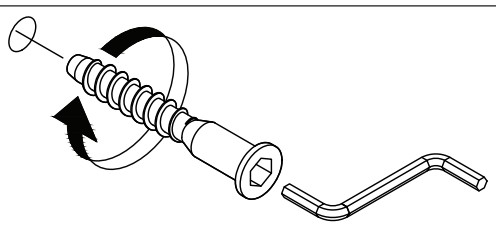
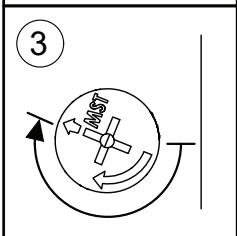
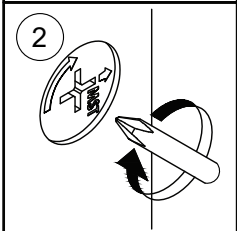
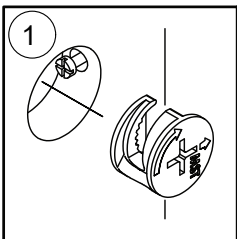
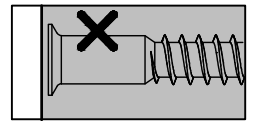
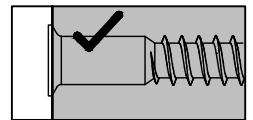

STEP 18

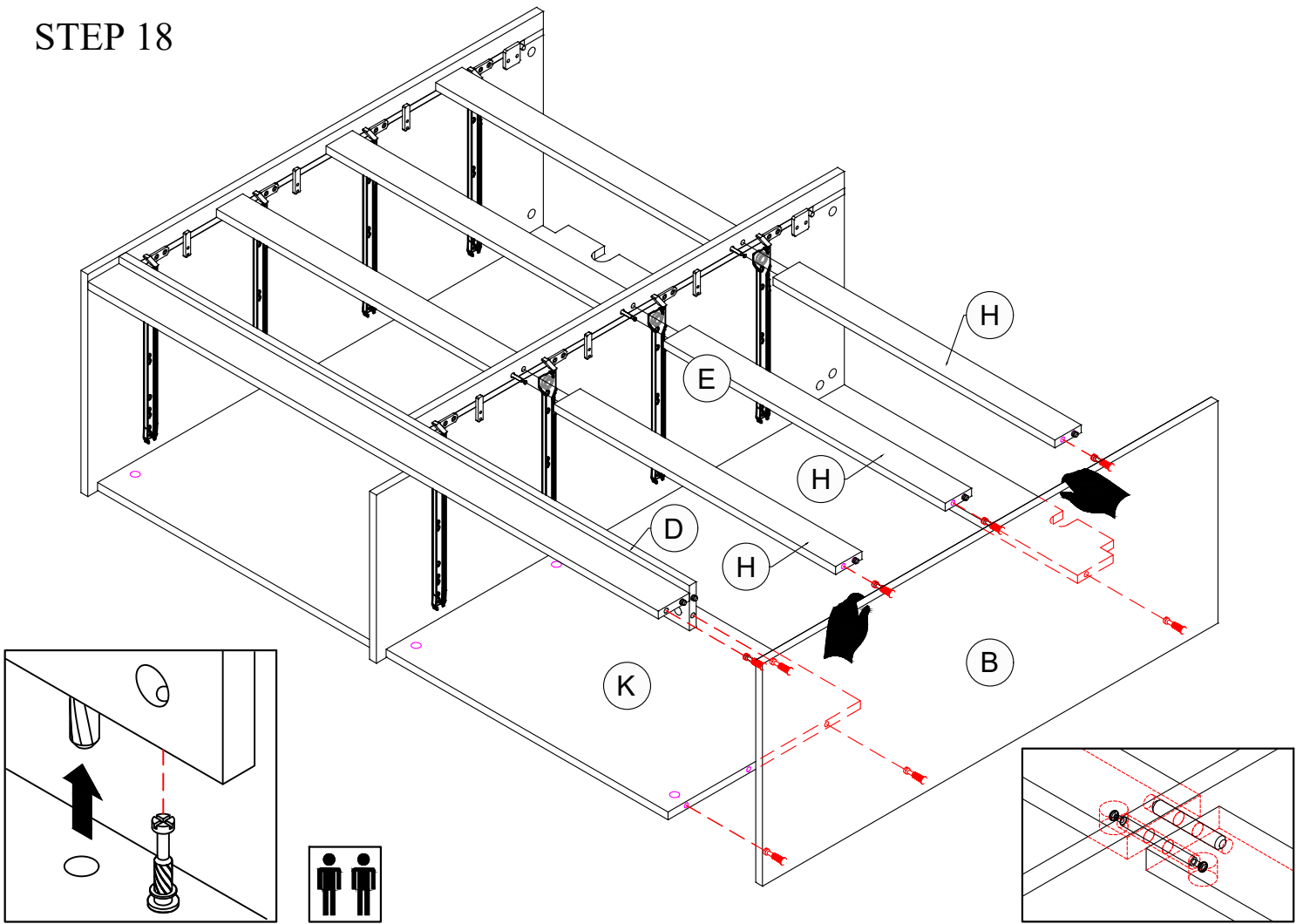

STEP 19

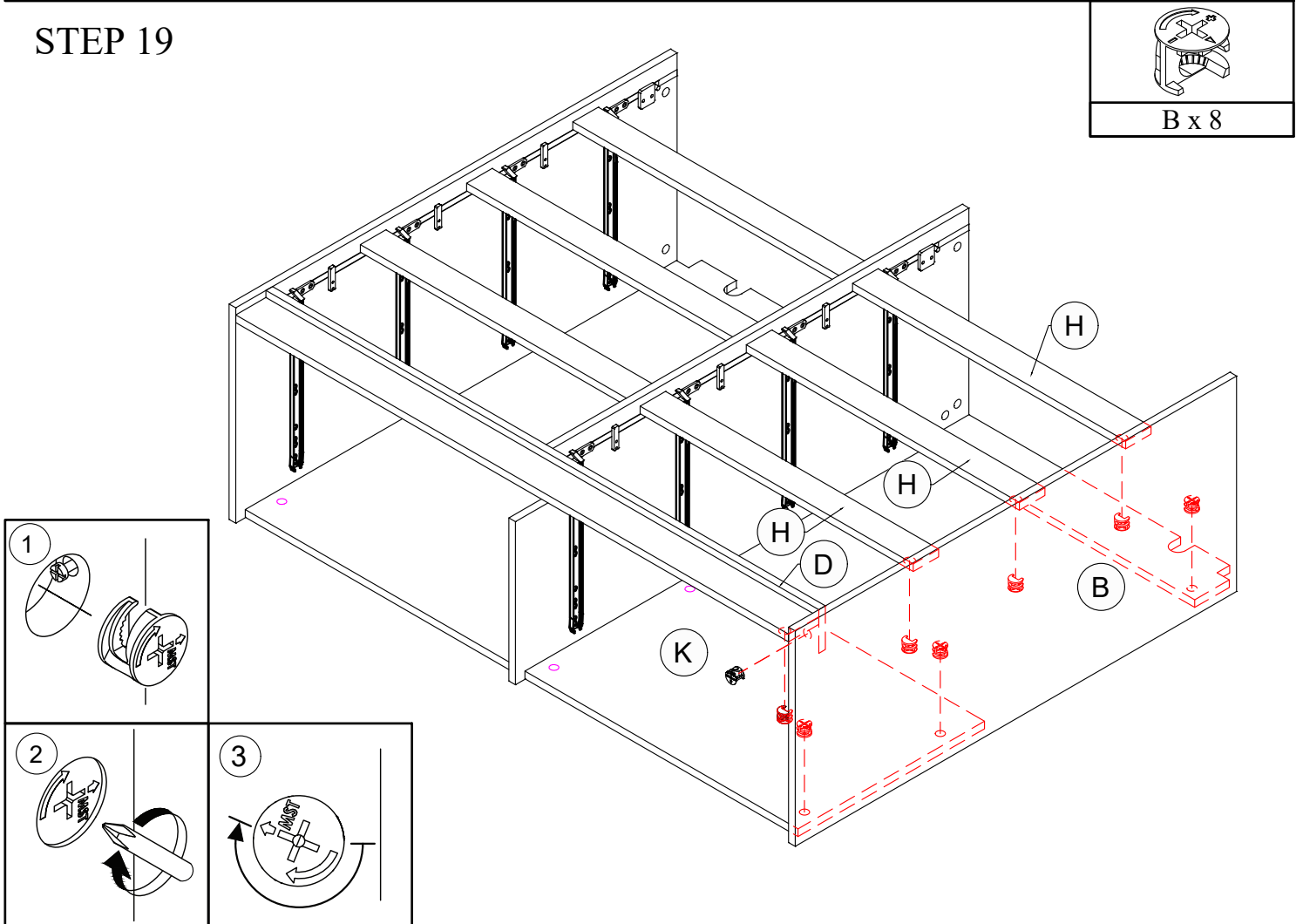

STEP 20

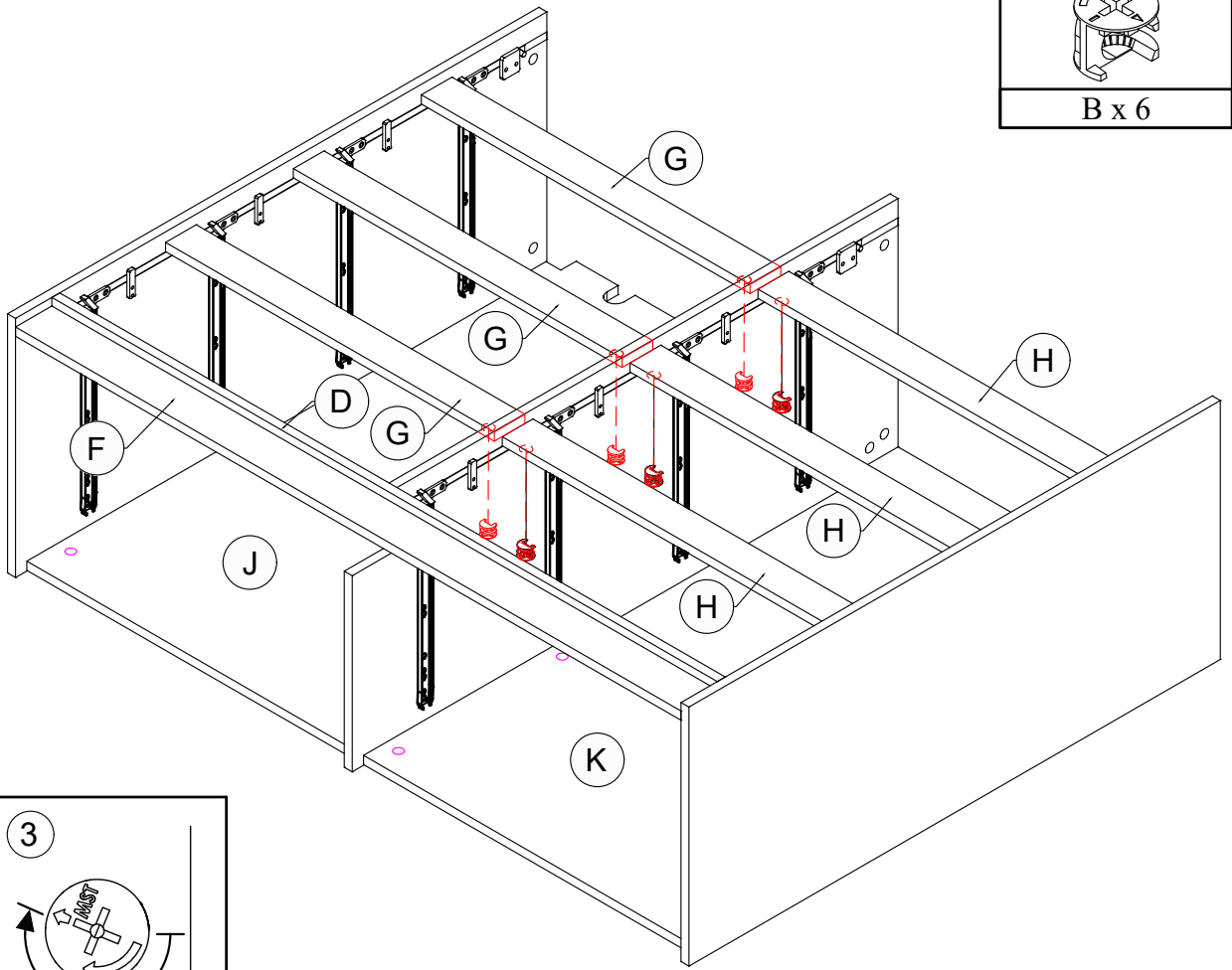
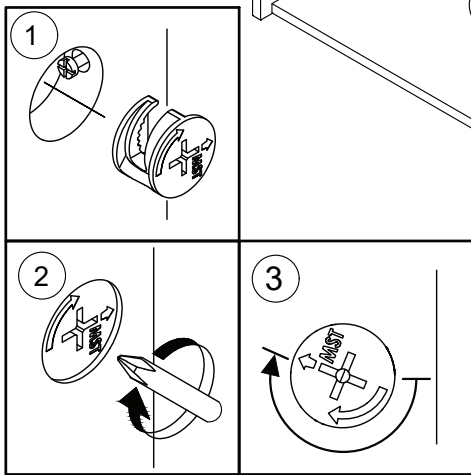
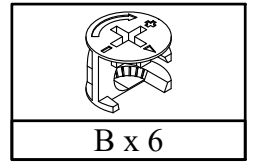

STEP 21

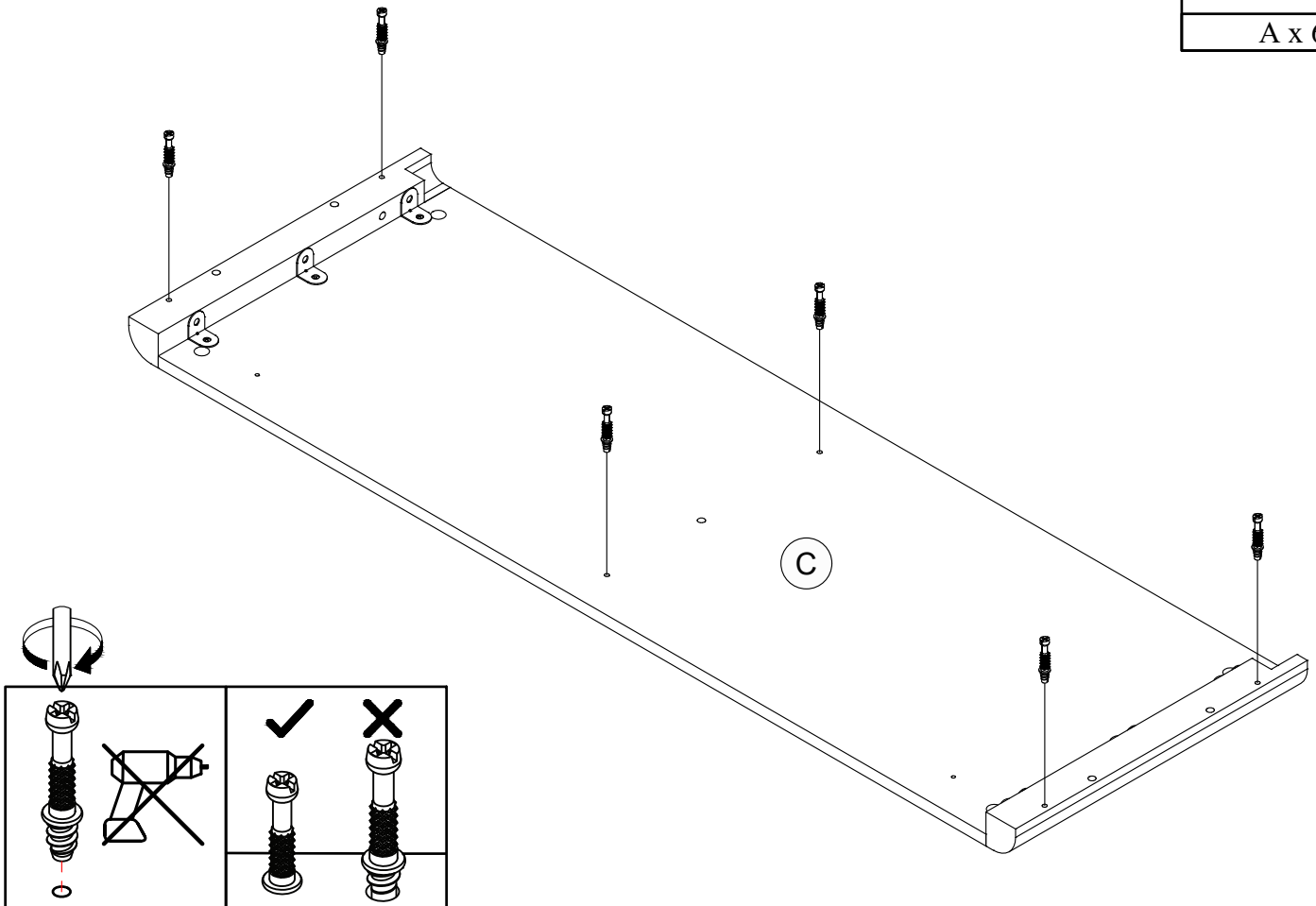
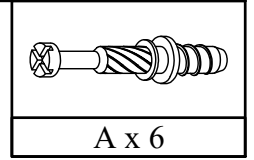

STEP 22

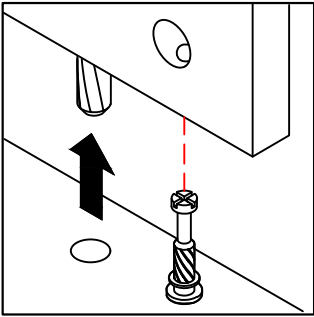
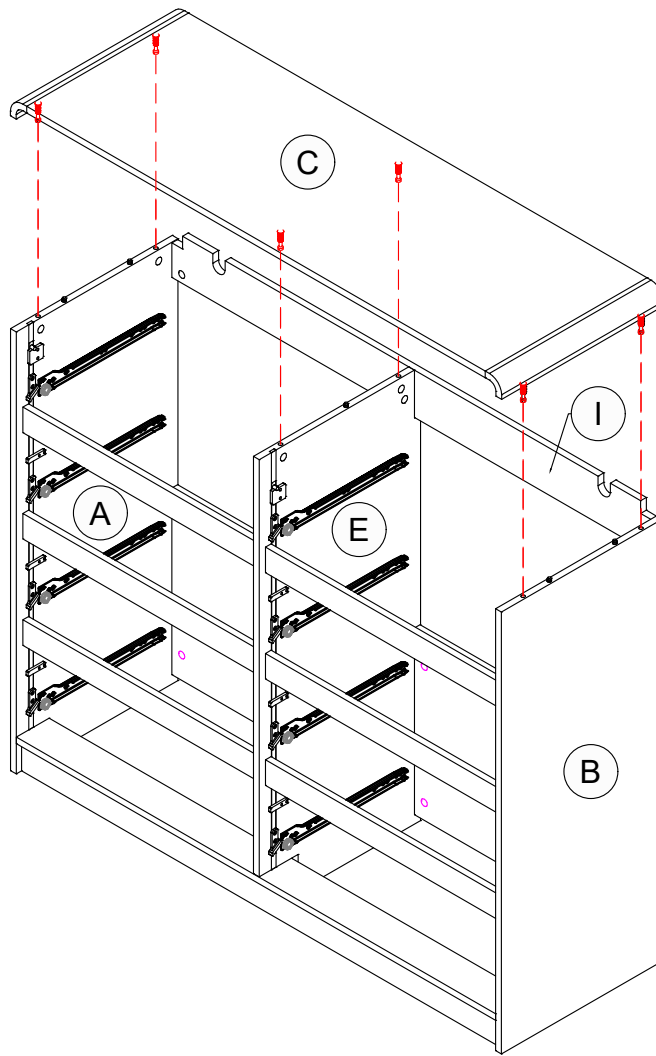

STEP 23

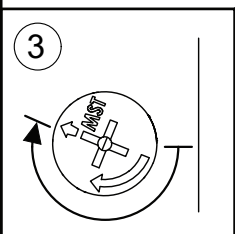
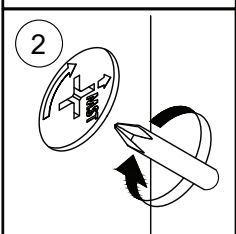
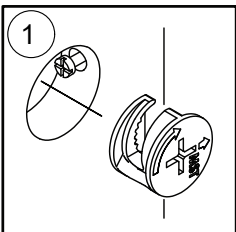
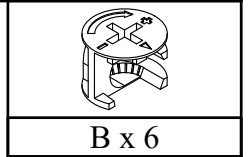
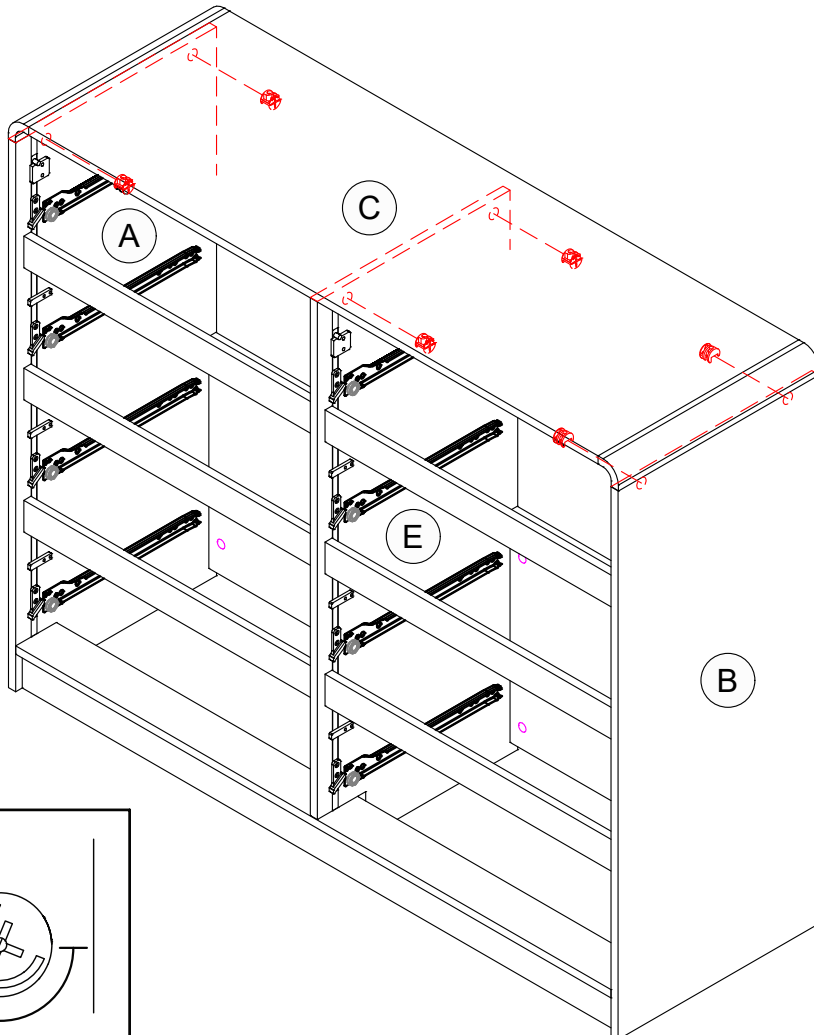

STEP 24

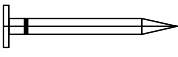
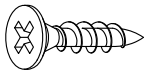
	
I x 6	F x 8

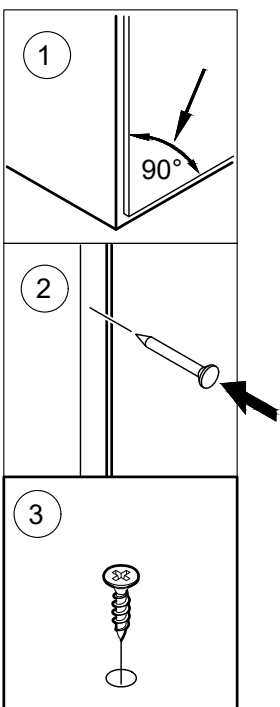
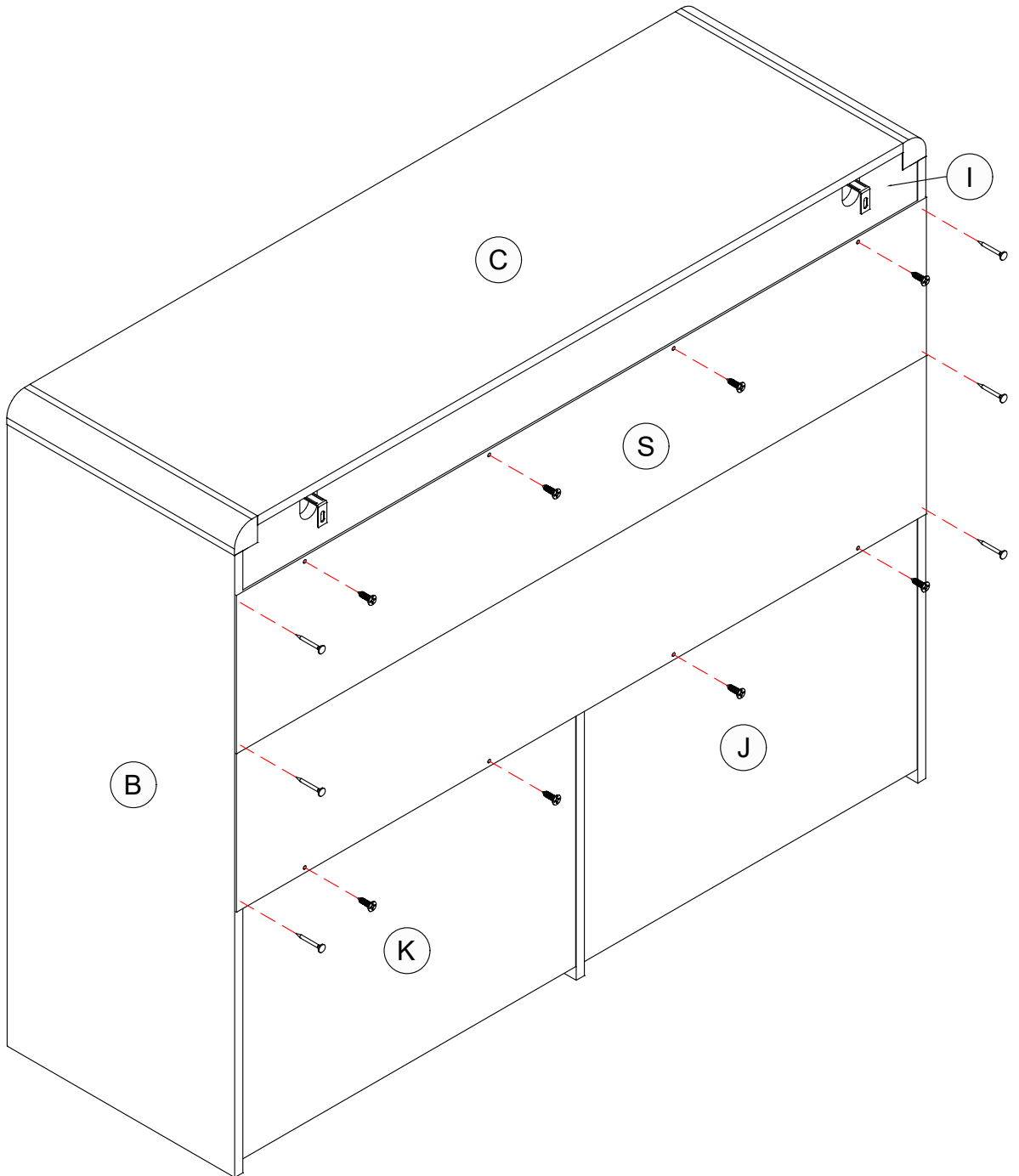

FURNITURE TIPPING RESTRAINT SEGURO CONTRAVOLCADO DE MUEBLES DISPOSITIF DÉ SÉCURITÉ POUR MEUBLES

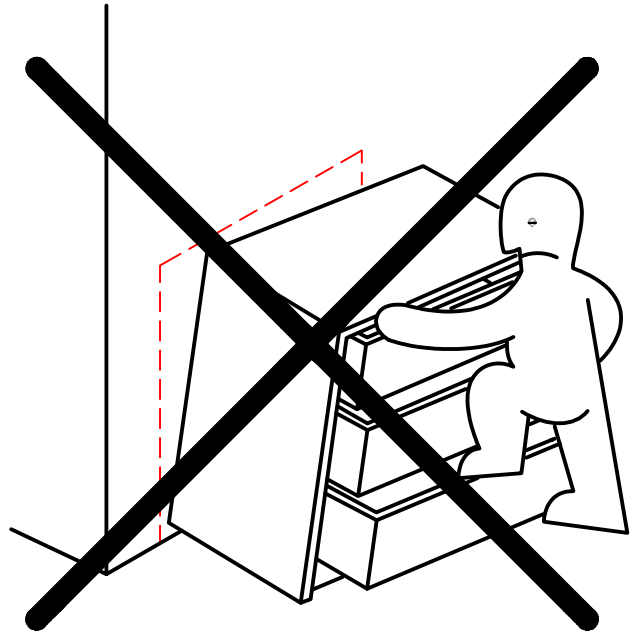
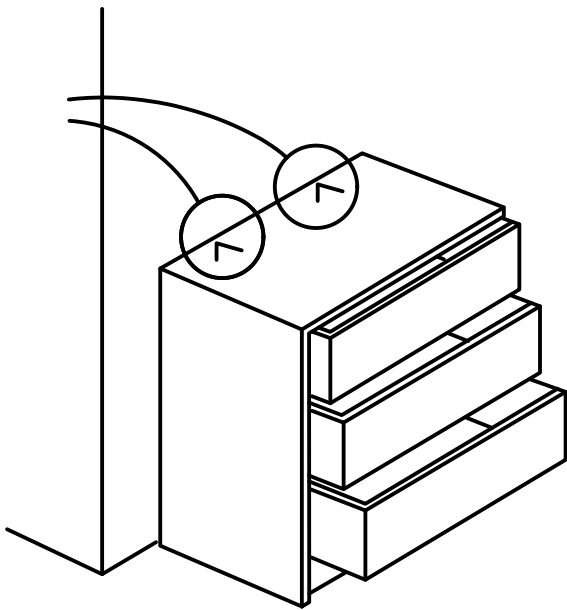

STEP 25

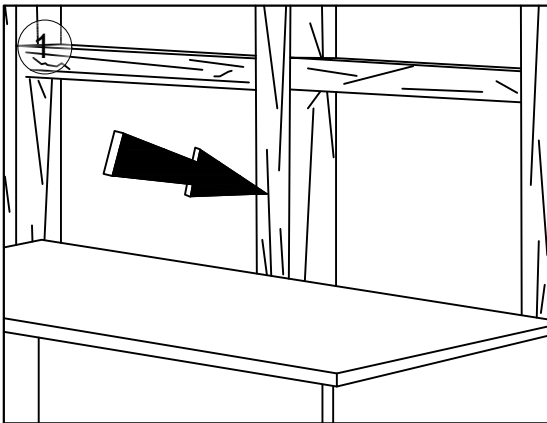

Locate a wall stud:

- Move the furniture unit to its final position to the wall.
- Locate a wall stud behind the furniture unit.

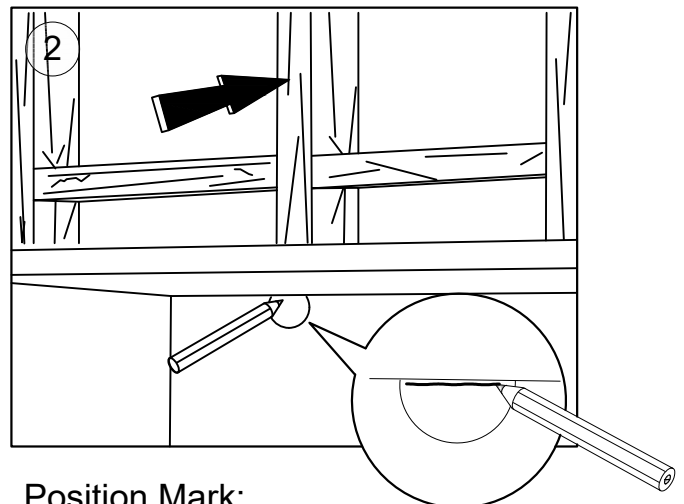

Position Mark:

- Use the Pencil to mark the positioning hole on a wall stud.

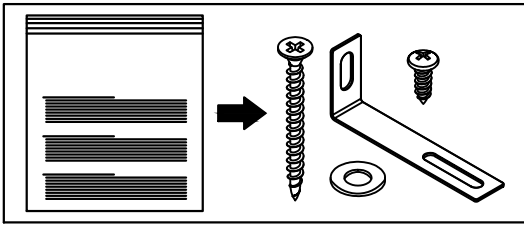

AA x 2	BB x 2	CC x 2	DD x 2

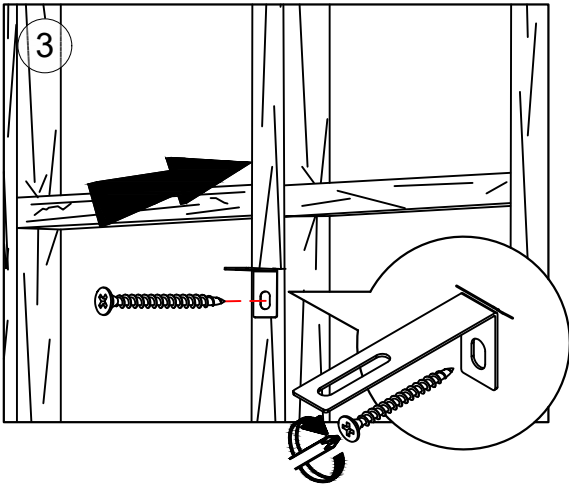

Screw the safety bracket to the wall stud:

- Screw the safety bracket (AA) to the wall stud with Screw (DD).

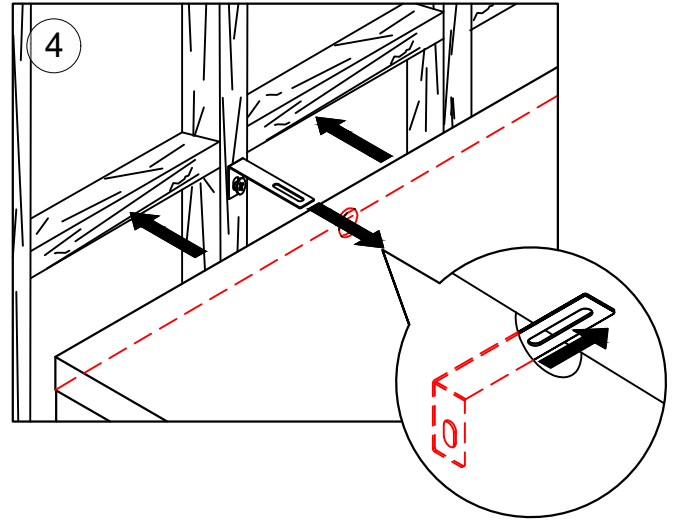

Move the furniture to the wall stud :

- Move the furniture to the wall stud and make sure the safety bracket is in the hole.

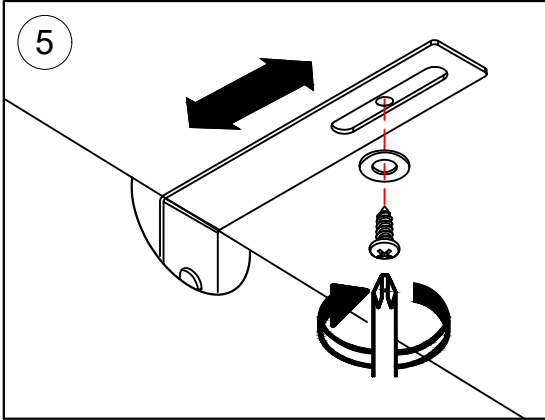

Screw the safety bracket to the furniture :

- Screw the safety bracket to the bottom Top Furniture with Flat Washer (BB) and Screw (DD).

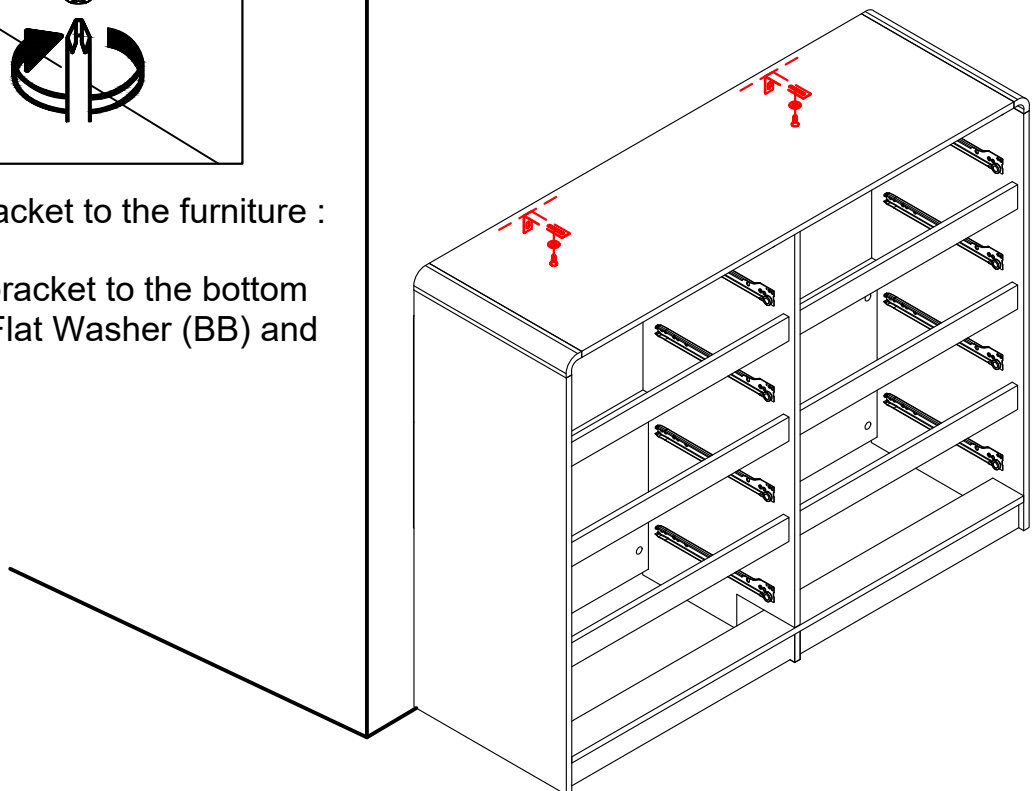

STEP 26

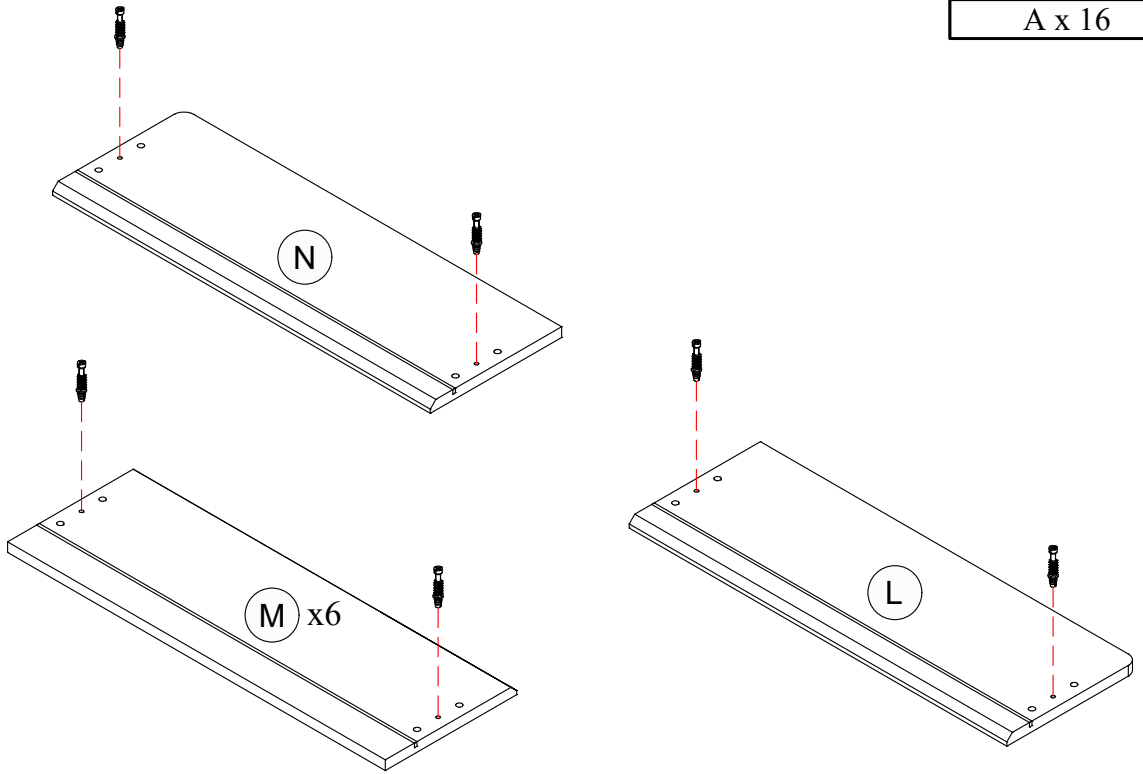
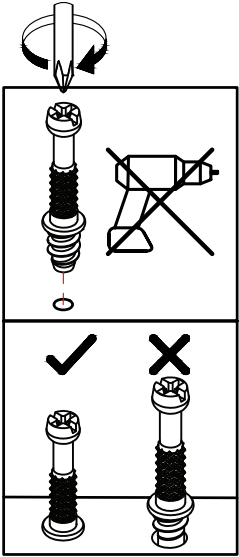
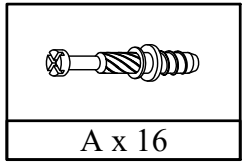

STEP 27

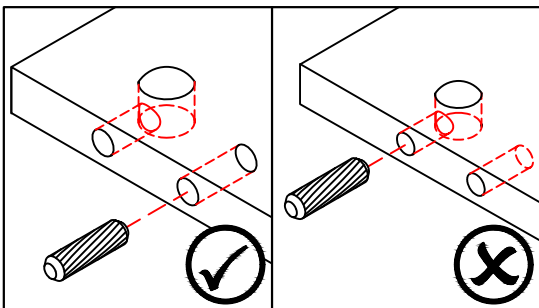
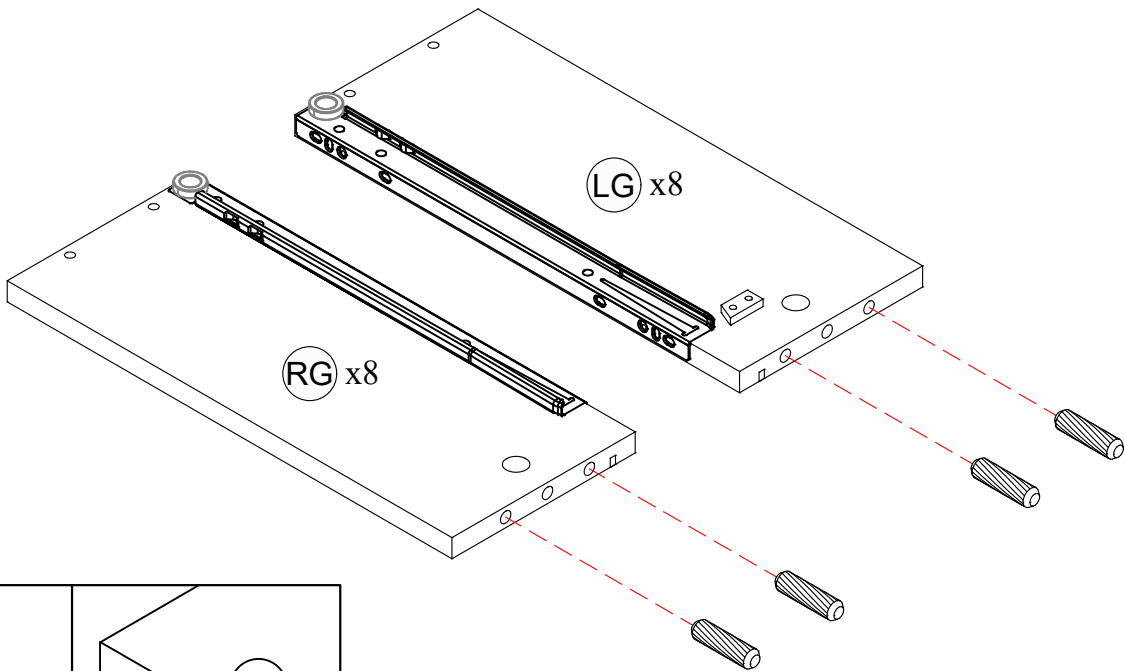
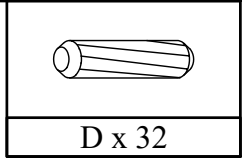

(x8)

STEP 28

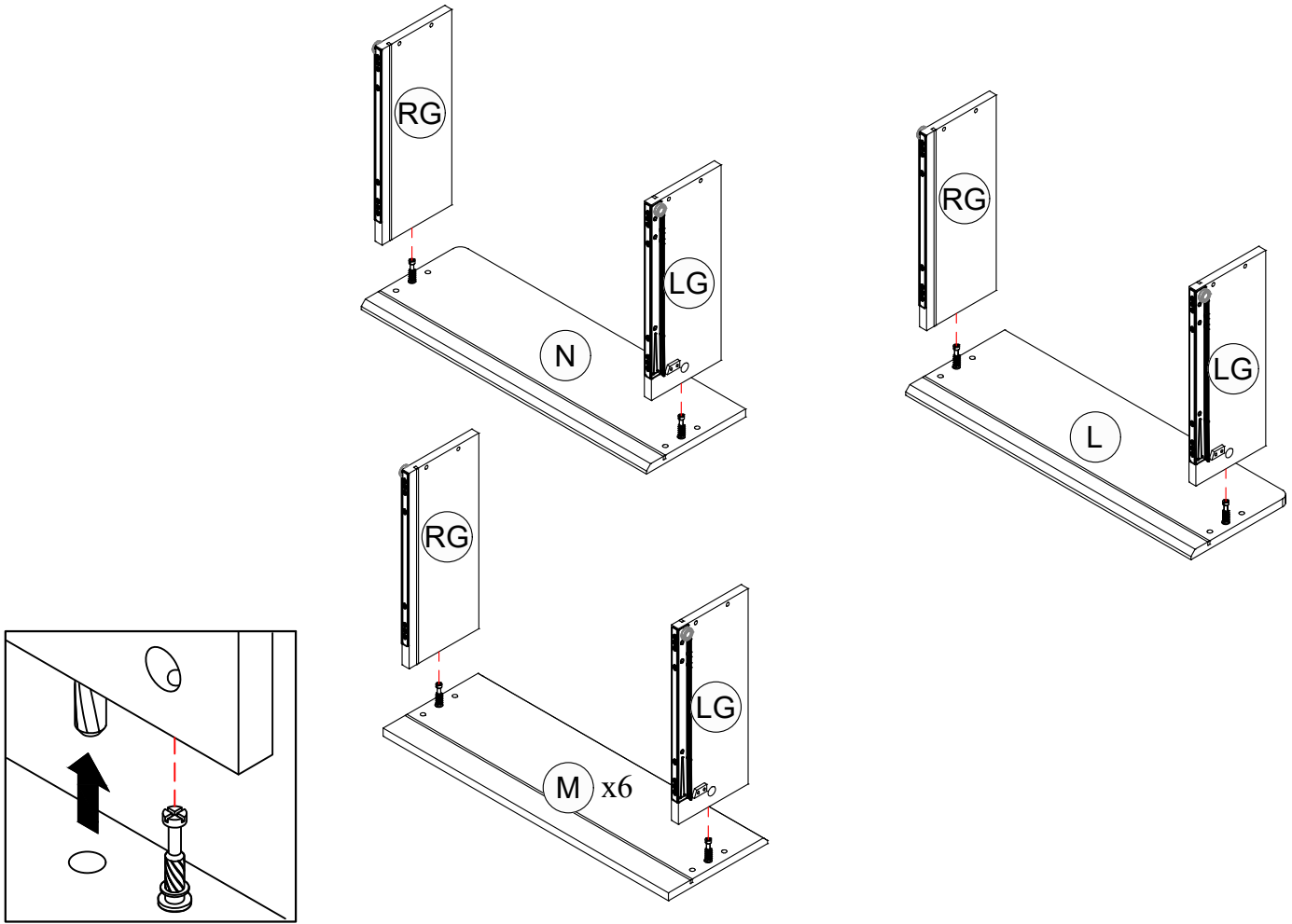

STEP 29

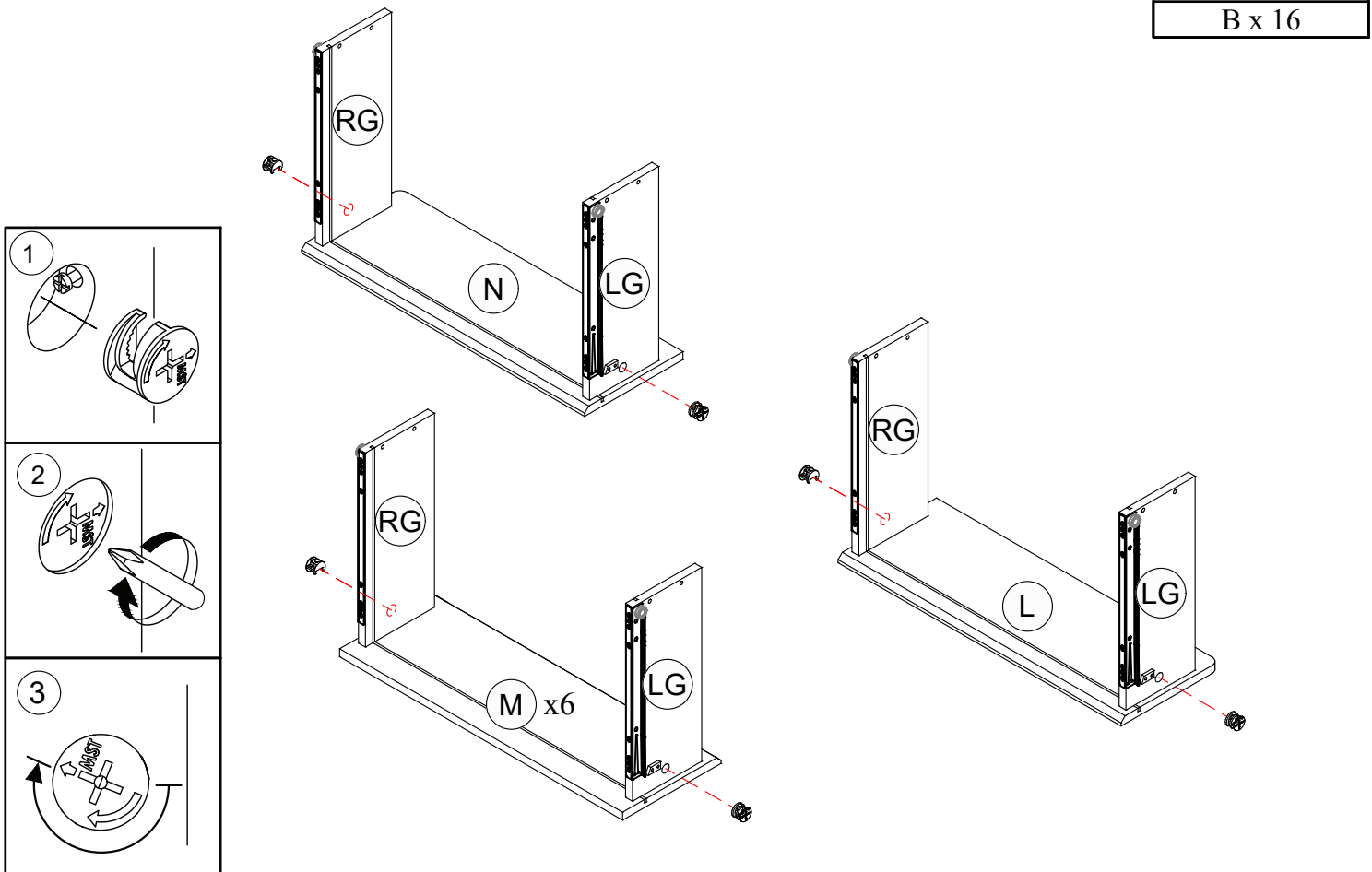
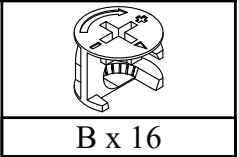

STEP 30

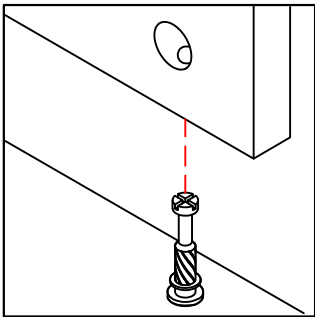
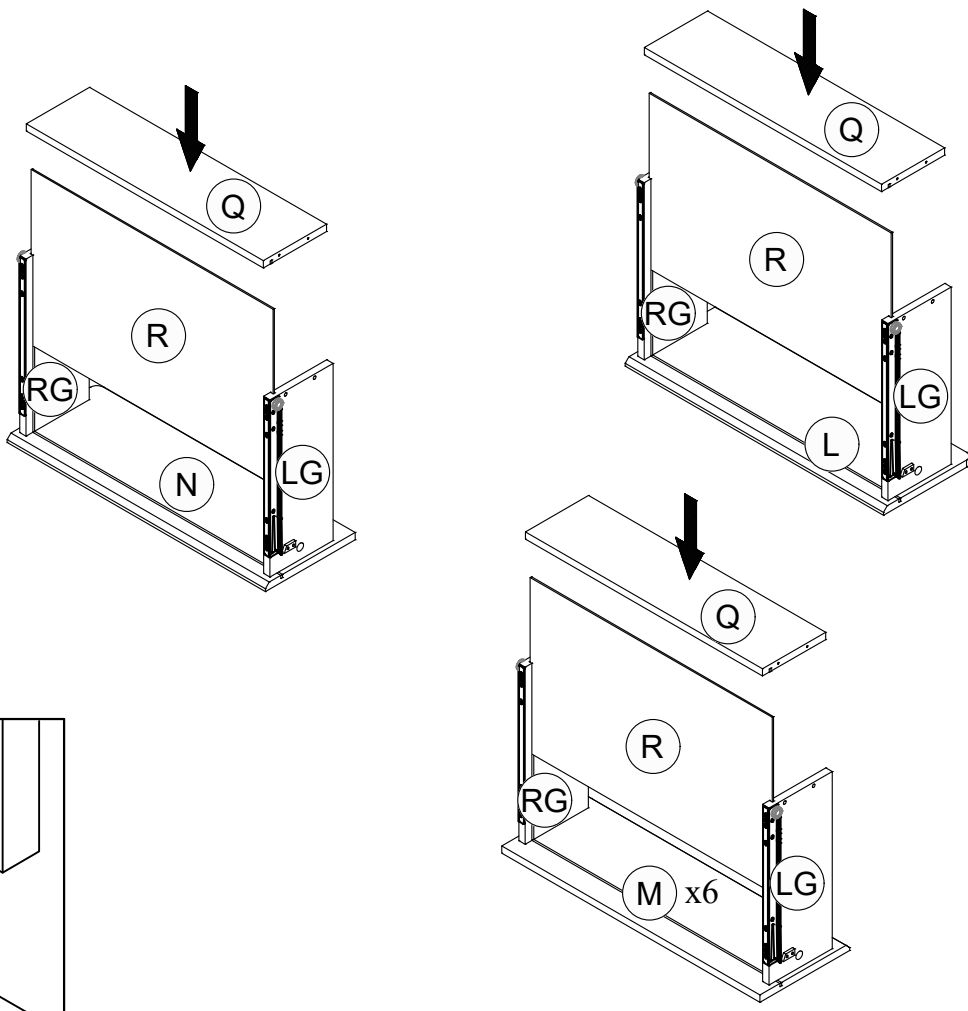

STEP 31

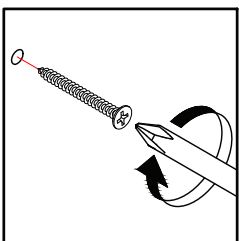
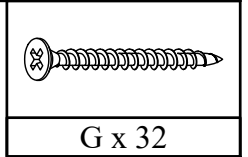
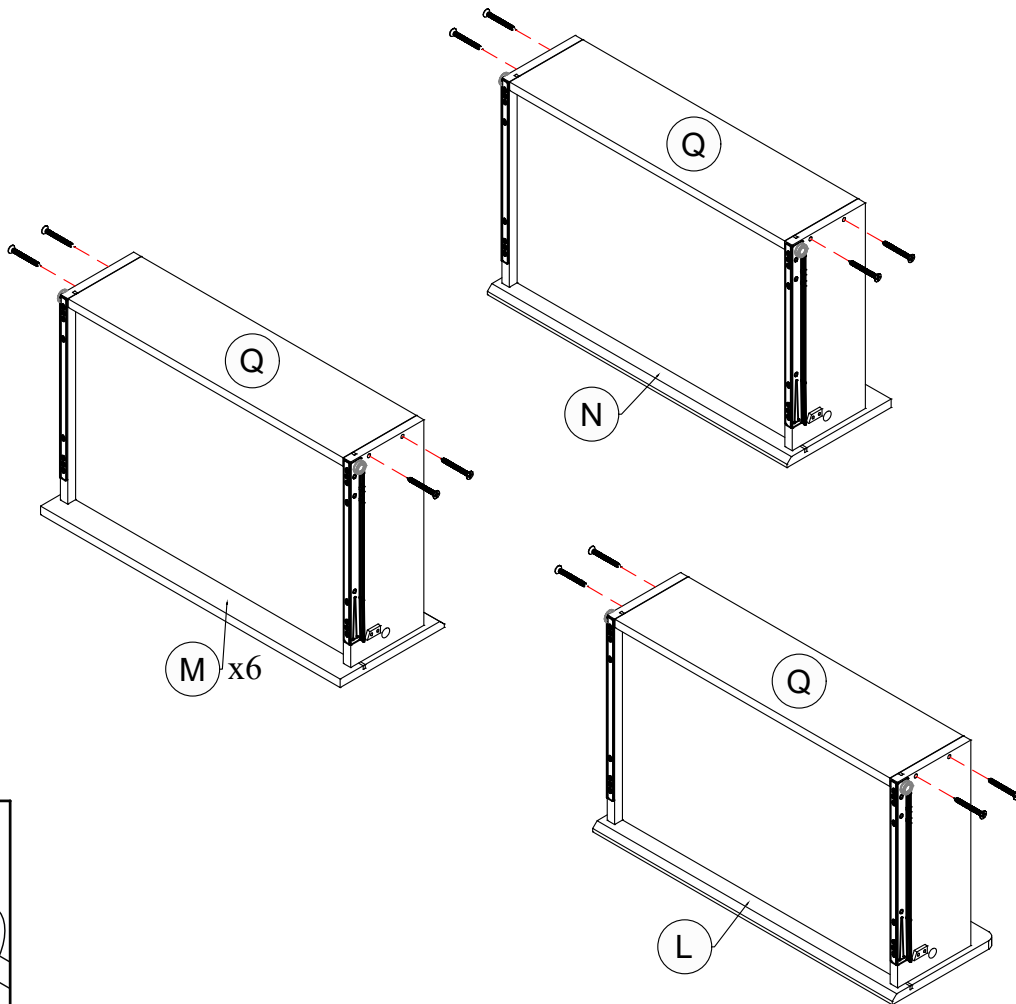

DRAWER INTERLOCK SYSTEM

SYSTÈME DE VERROUILLAGE DES TIROIR

SISTEMA DE INTERBLOQUEO DE CAJON

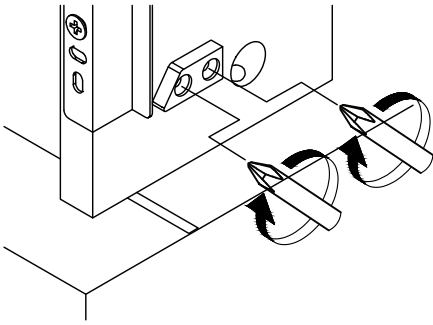

Interlock installation instruction for maintenance / replacement only

Instrucciones de instalación de interbloqueo solo para mantenimiento/reemplazo

Instructions d'installation de l'interverrouillage pour maintenance / remplacement uniquement

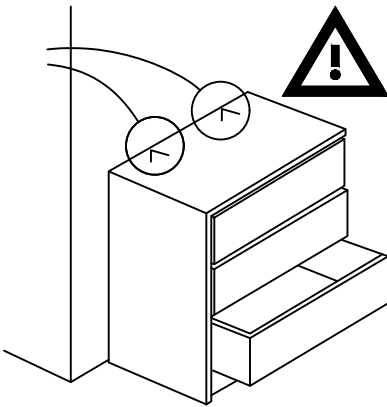

Never use the unit without the interlock system installed following the instructions

Ne jamais utiliser l'appareil sans le verrouillage installé en suivant les instructions

Nunca utilice la unidad sin el sistema de enclavamiento instalado siguiendo las instrucciones

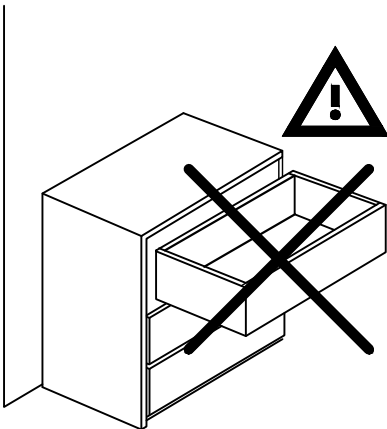

This item features an interlock system that allows for the opening of only one drawer at a time, preventing the simultaneous opening of multiple drawer.

Cet article est doté d'un système de verrouillage qui permet l'ouverture d'un seul tiroir à la fois, empêchant l'ouverture simultanée de plusieurs tiroirs.

Este artículo cuenta con un sistema de bloqueo que permite la apertura de un solo cajón a la vez, evitando la apertura simultánea de varios cajones.

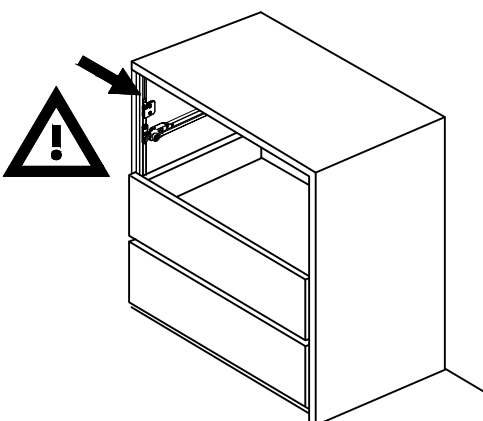

Do not defeat or remove the drawer interlock system. It is important stability and safety system.

Ne pas défaire ou retirer le système de verrouillage du tiroir; il s'agit d'un important système de stabilité et de sécurité.

No anule ni retire el sistema de bloqueo del cajón.

Es importante el sistema de estabilidad y seguridad.

STEP 32

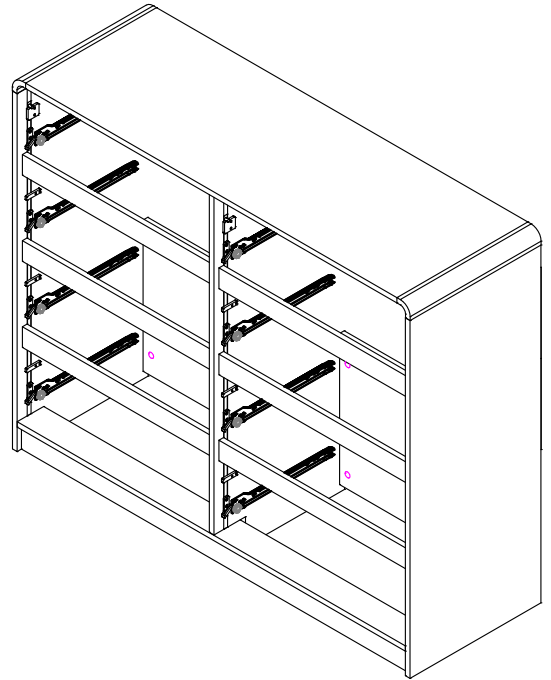
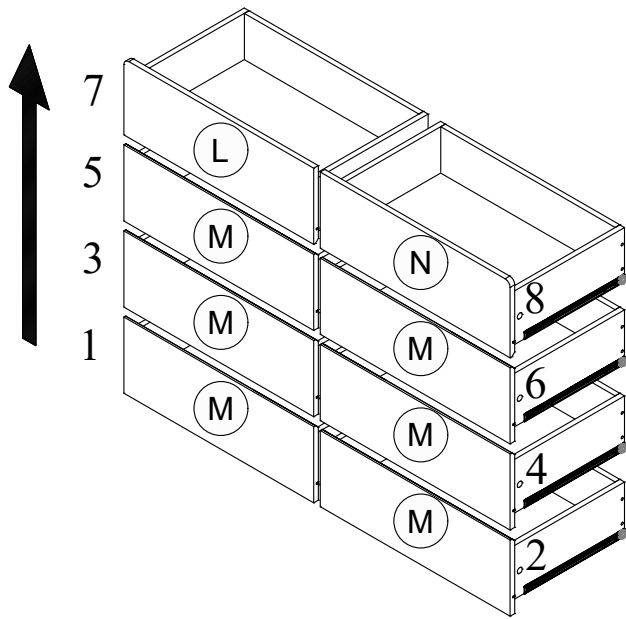

STEP 33

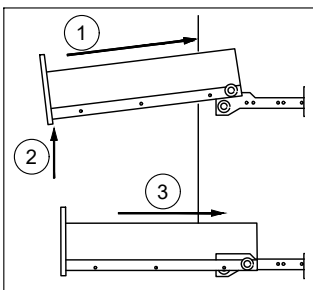
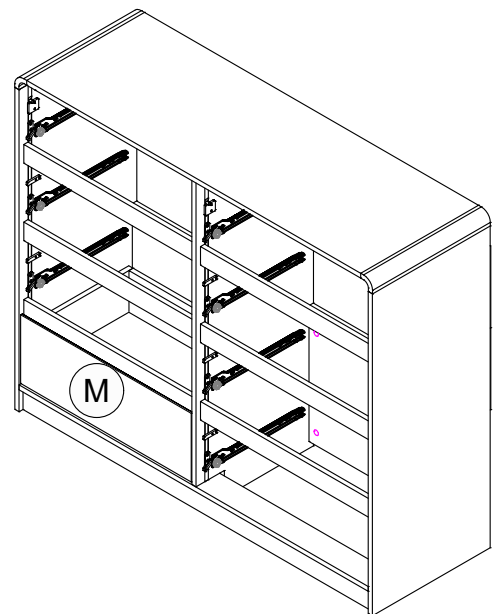
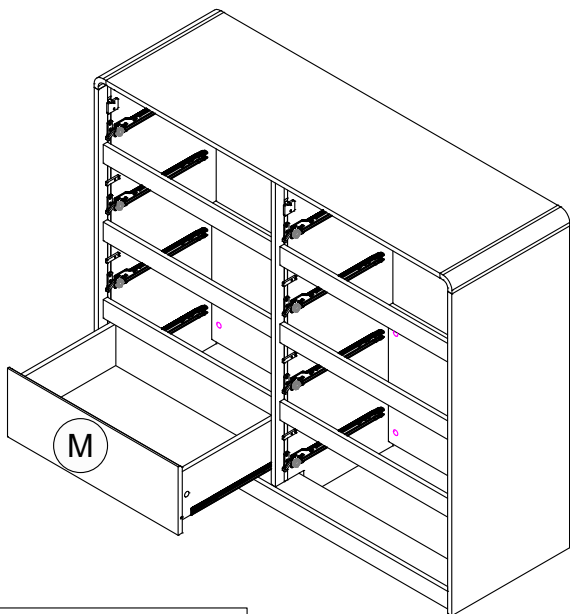

STEP 34

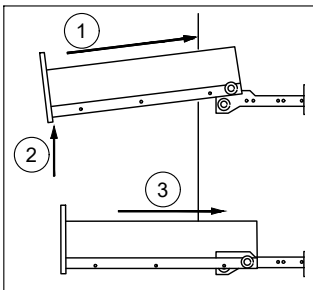
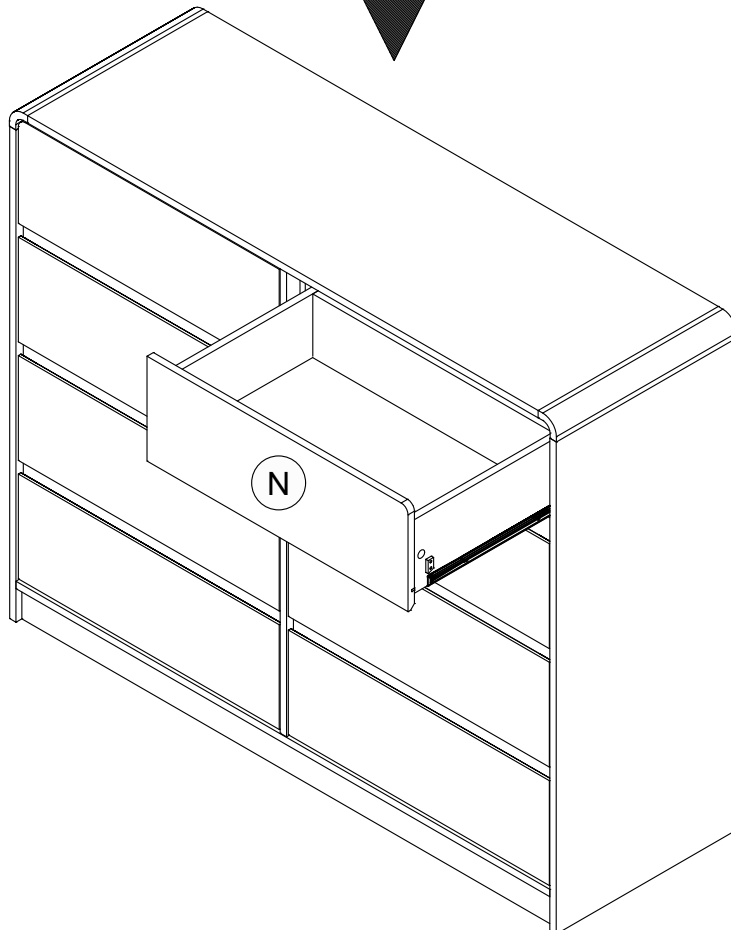
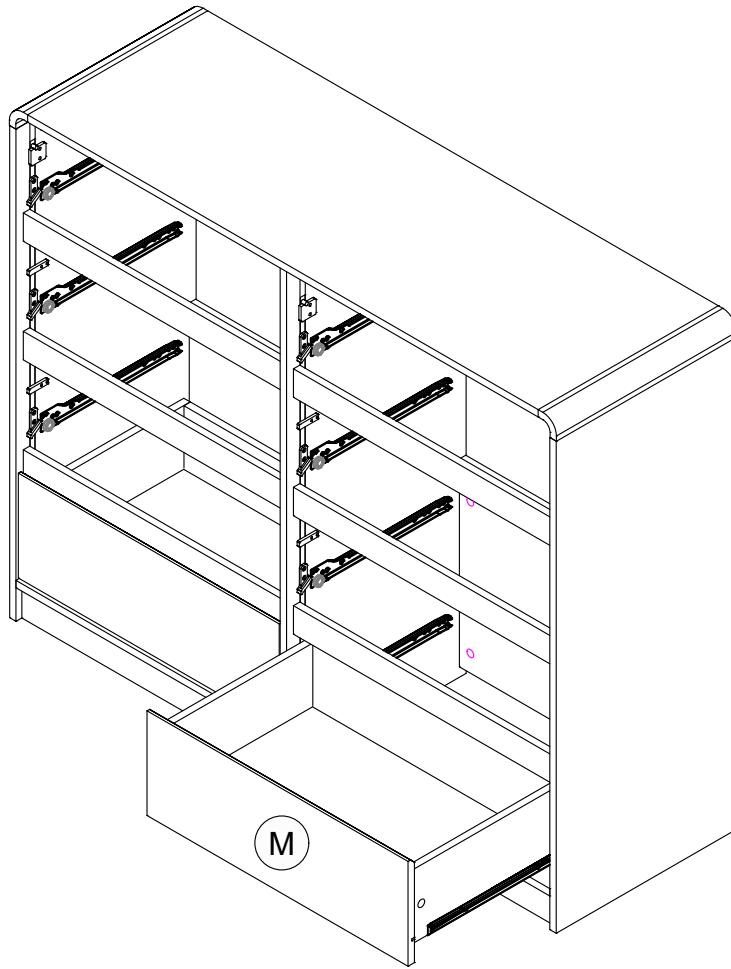

MAXIMUM LOADS CHARGES MAXIMALES / CARGA MAXIMA

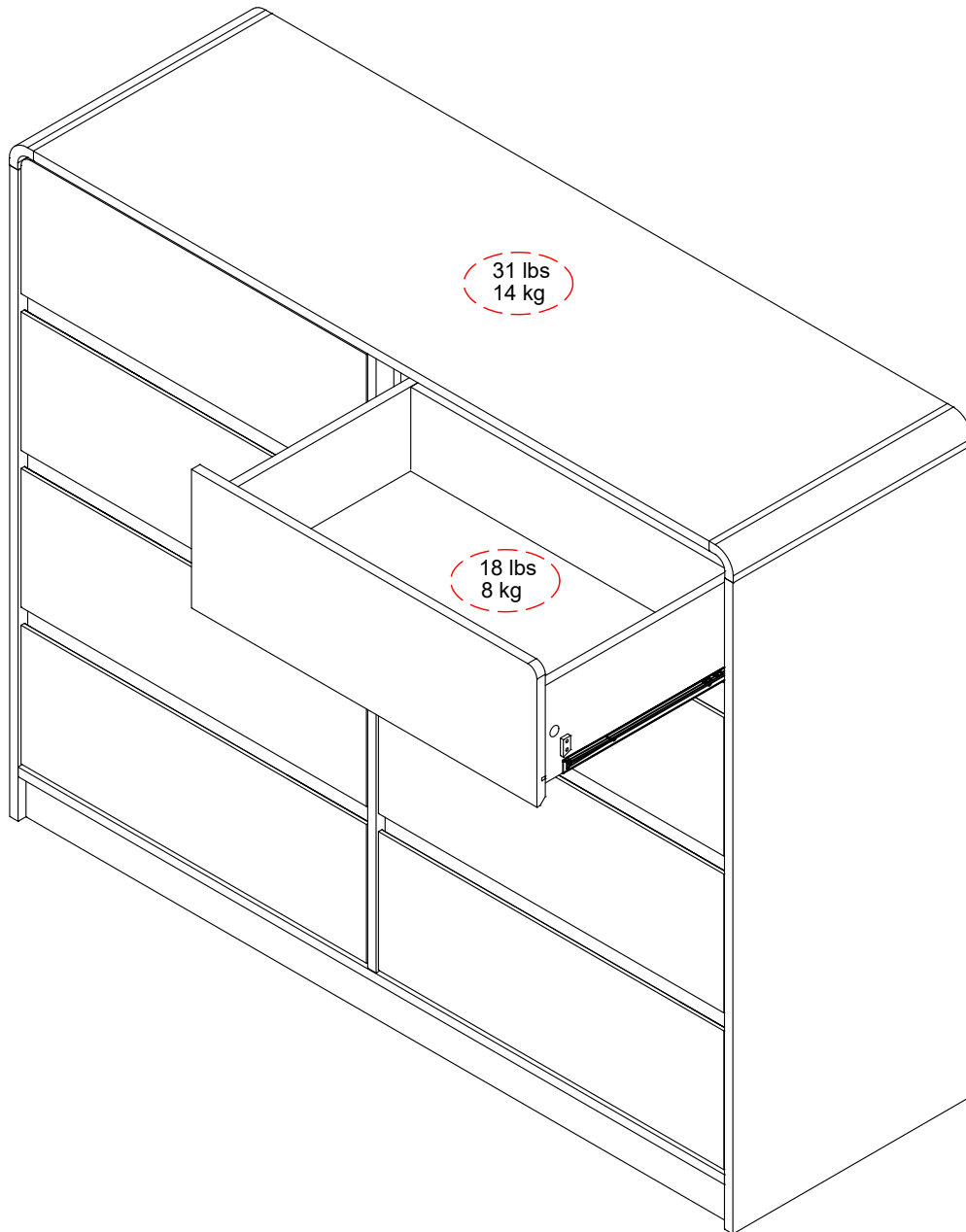

This product is designed to withstand the weight noted on the plan. We are not responsible for the breakage of parts or any injury caused by failure to comply with this recommendation.

Ce produit est conçu pour supporter le poids indiqué sur le plan. Nous ne sommes pas responsables de la casse de pièces ou toute blessure causée par le non-respect de cette recommandation.

Este producto está diseñado para soportar el peso indicado en el plano. No somos responsables de la rotura de piezas o cualquier lesión causada por el incumplimiento de esta recomendación.